

User Manual

SmartBond Production Line Tool

UM-B-174

Abstract

This document describes the SmartBond Production Line Tool (PLT) for DA1459x wireless SoC family of products. The various software applications, as well as the PLT hardware are explained in detail. The purpose of this document is to give guidance on how to use the various PLT components.

Contents

Abstract 1

Contents 2

Figures..... 4

Tables 7

1 Terms and Definitions..... 9

2 References 11

3 Introduction..... 12

4 Hardware 13

 4.1 Hardware block diagram 13

 4.2 Printed circuit board layout 14

 4.3 PLT power supply 15

 4.4 DUT connector 15

 4.5 Data streaming..... 16

 4.5.1 Normal operation 16

 4.5.2 Crystal trimming..... 17

 4.5.3 Loopback operation 17

 4.6 Golden Unit 18

 4.6.1 GU reset 18

 4.7 Current measurements 19

 4.8 Jumper settings..... 20

 4.8.1 J26 - current measurements..... 20

 4.8.2 J47, J46 - GU reset..... 20

 4.8.3 J37 - GU programming 21

 4.9 PLT functional blocks 23

5 Software 24

 5.1 Introduction 24

 5.2 Software package contents..... 25

 5.3 Prerequisites 28

 5.4 System requirements 28

 5.5 Limitations 29

 5.6 Building the Code..... 29

 5.7 Executing the applications 32

 5.8 Test sequence..... 38

 5.8.1 DA1459x test sequence 38

 5.9 VBAT/Reset signals operation 42

 5.9.1 VBAT Only 42

 5.9.2 VBAT On with Reset..... 43

 5.10 Custom memory data..... 43

 5.10.1 Custom data CSV file format 44

 5.11 Golden Unit scan test..... 45

 5.12 Creating PLT firmware files..... 46

 5.12.1 Golden Unit firmware 46

SmartBond Production Line Tool

5.12.2	DA1459x firmware	47
6	Applications	48
6.1	Introduction	48
6.2	CFG PLT application.....	48
6.2.1	XML and XSD files.....	50
6.2.2	Hardware setup	51
6.2.3	General	54
6.2.4	BD addresses	57
6.2.5	DUT hardware setup.....	59
6.2.6	Test settings	60
6.2.7	Memory Functions	78
6.2.8	Memory header.....	80
6.2.9	Debug Settings	85
6.2.10	Security	86
6.3	GUI PLT application	86
6.3.1	GUI PLT settings	89
6.3.2	Running the GUI PLT and executing tests	90
6.3.3	Debug console.....	94
6.3.4	DUT log file	95
6.3.5	CSV file	96
6.4	CLI PLT application.....	96
6.4.1	CLI commands.....	97
6.4.2	Running the CLI and executing tests.....	98
6.4.3	Using CLI commands with arguments.....	101
6.5	GU Upgrade application.....	101
6.5.1	Introduction window	101
6.5.2	Hardware Version	102
6.5.3	Power Supply.....	103
6.5.4	Golden Unit Reset	104
6.5.5	GU COM Port	105
6.5.6	Burn Firmware	106
7	Example Usage.....	108
	Appendix A Top View of PLT PCB Version D.....	113
	Appendix B Electrical Schematics	114
	Appendix C Hardware Modifications PLT Version D	118
	Appendix D Application Hardware Design Considerations	120
	Appendix E Suggestions about Hardware and Cabling	121
	Appendix F RF Path Losses Calibration	124
F.1	Prerequisites	124
F.2	Setup.....	125
F.3	Procedure.....	127
	Appendix G Building Binaries Using Smart Snippets™ Studio	134
	Appendix H Automatic GU COM Port Find	135

SmartBond Production Line Tool

Appendix I Improving Cabling Between PLT and DUTs	137
Appendix J FTDI Driver Removal and Installation	139
Appendix K DA1459x DK Pro Motherboard Connection	140
Appendix L Connecting DUT with Battery Supply	142
Appendix M User Interfaces Shortcut Keys	143
Appendix N DA1459x Supported QSPI Flash Memories	144
Appendix O Bluetooth® LE Tester Measurement Results	145
O.1 TX power	145
O.2 Frequency offset	146
O.3 Modulation index	146
O.4 Error response	147
Appendix P CSV Log File Contents	150
P.1 CSV log file example.....	154
Appendix Q DUT Status Codes	158
Appendix R Golden Unit Status Codes	166
Revision History	170

Figures

Figure 1. Production Line Tool hardware	12
Figure 2. Production Line Tool hardware board block diagram	13
Figure 3. Top view of the PLT hardware board	14
Figure 4. PLT hardware power connections.....	15
Figure 5. Production Line Tool DUT connections.....	15
Figure 6. CPLD UART data streams	16
Figure 7. CPLD XTAL trim pulse data stream	17
Figure 8. CPLD UART loopback data stream	17
Figure 9. Golden Unit	18
Figure 10. GU reset circuit.....	19
Figure 11. VBAT DUT current measurement setup	19
Figure 12. Connections for "Floating Current" measurements.....	20
Figure 13. Location of J46 jumper.....	21
Figure 14. Location of J47 jumper.....	21
Figure 15. J37 - GU programming jumper schematics	21
Figure 16. Location of J37 jumper.....	22
Figure 17. PLT functional blocks	23
Figure 18. Production Line Tool software block diagram	24
Figure 19. SmartBond PLT software package contents.....	25
Figure 20. DA1459x test sequence	41
Figure 21. VBAT Only.....	42
Figure 22. VBAT On with Reset	43
Figure 23. Custom memory data CSV file example	44
Figure 24. Golden Unit scan test.....	45
Figure 25. Golden Unit scan test example parameters	45
Figure 26. Firmware files.....	46
Figure 27. Folder Contents of fw_files.....	46
Figure 28. CFG PLT startup window	48
Figure 29. CFG PLT with erroneous configuration parameter	49

SmartBond Production Line Tool

Figure 30. XSD Schema file example	50
Figure 31. Station identification	51
Figure 32. Device IC.....	51
Figure 33. Active DUTs	52
Figure 34. DUT COM ports.....	52
Figure 35. Golden Unit COM port.....	53
Figure 36. VBAT/Reset mode selection	53
Figure 37. Statistics	54
Figure 38. Test options.....	55
Figure 39. Reset polarity	55
Figure 40. BD Address Assignment	57
Figure 41. Example for Load from File mode.....	58
Figure 42. UART Baud Rate	59
Figure 43. Reset Polarity.....	59
Figure 44. VBAT Level Log	60
Figure 45. Factory Timestamp Read.....	60
Figure 46. XTAL Trim	60
Figure 47. GPIO Watchdog Operation	60
Figure 48. Scan DUT Advertise Test.....	61
Figure 49. Golden Unit RF Tests.....	62
Figure 50. BLE Tester General Settings	63
Figure 51. BLE Tester TX Power	64
Figure 52. BLE Tester Frequency Offset.....	65
Figure 53. BLE Tester Modulation Index.....	66
Figure 54. BLE Tester RX Sensitivity	67
Figure 55. Path Losses per DUT	68
Figure 56. GPIO/LED Tests.....	68
Figure 57. GPIO Connection Test	69
Figure 58. Sensor Test (SPI).....	70
Figure 59. Sensor Test (I2C).....	70
Figure 60. Custom Test.....	71
Figure 61. External 32 kHz Test.....	72
Figure 62. Current Measurement Tests	73
Figure 63. Temperature Measurement Test.....	76
Figure 64. Scan Test	77
Figure 65. Flash Memory.....	78
Figure 66. Memory Read test.....	79
Figure 67. Memory Read test example log file.....	79
Figure 68. Custom Memory Data	80
Figure 69. Configuration Script (part 1)	81
Figure 70. Configuration Script (part 2)	82
Figure 71. Debug Settings.....	85
Figure 72. Security	86
Figure 73. GUI PLT Main window	87
Figure 74. GUI PLT settings.....	89
Figure 75. GUI PLT - erroneous messages in Run Scripts Before Testing Starts.....	91
Figure 76. GUI PLT CS Write warning message.....	91
Figure 77. GUI PLT testing (1 of 2)	92
Figure 78. GUI PLT testing (2 of 2)	93
Figure 79. GUI PLT tests finished	93
Figure 80. Debug console	94
Figure 81. DUT log file.....	95
Figure 82. CSV file	96
Figure 83. CLI software Start window	97
Figure 84. CLI PLT print settings (x command)	99
Figure 85. CLI PLT DUT COM port enumeration (p command).....	100
Figure 86. CLI PLT testing.....	100

SmartBond Production Line Tool

Figure 87. CLI PLT testing finished	100
Figure 88. CLI with commands as arguments	101
Figure 89. GU Upgrade - Introduction page	102
Figure 90. GU FW Upgrade - exit message	102
Figure 91. GU FW Upgrade - Hardware Version	103
Figure 92. GU FW Upgrade - hardware version compatibility	103
Figure 93. GU FW Upgrade - Power Supply	104
Figure 94. GU FW Upgrade - power supply pop-up	104
Figure 95. GU FW Upgrade - Golden Unit Reset	105
Figure 96. GU firmware Upgrade - Golden Unit reset message for Manual mode	105
Figure 97. GU firmware Upgrade - GU COM Port	106
Figure 98. GU firmware Upgrade - burn firmware	106
Figure 99. GU Upgrade - burn firmware pop-up message	107
Figure 100. GU firmware Upgrade - burn firmware success	107
Figure 101. Top view of PLT PCB version D	113
Figure 102. VBAT and VPP control from CPLD	114
Figure 103. CPLD DUT UART connections	114
Figure 104. CPLD FTDI and GU control connections	115
Figure 105. FTDI chip for USB UART to DUTs 1, 2, 3, and 4	115
Figure 106. Quad USB HUB	116
Figure 107. Golden Unit - dedicated USB port and FTDI chip	116
Figure 108. Golden Unit - GU LED and SPI Flash memory	117
Figure 109. VBAT_DUT and VDDIO supplies	117
Figure 110. GU supply and VPP generation	117
Figure 111. DA14580_RD_tester version D	118
Figure 112. Jumper J47 added next to Golden Unit socket	118
Figure 113. R365 (10 kΩ) added next to Reset button	118
Figure 114. R365, J47 and RESET shown in electrical schematic	119
Figure 115. Possible solution of antenna on cable and fixed radius of DUTs to antenna	121
Figure 116. Possible solution of antenna on cable and DUTs put in line	122
Figure 117. Example locations and RSSI readouts of horizontal antenna	122
Figure 118. Setup diagram	125
Figure 119. Build pxp_reporter using SmartSnippets™ Studio	134
Figure 120. Example of twisted pair cable with 4 pairs and ferrite	137
Figure 121. Location of pull-down resistors	137
Figure 122. Anti-ringing solution	138
Figure 123. DA1459x Pro Motherboard DK wiring	141
Figure 124. Example CSV log file	154

SmartBond Production Line Tool
Tables

Table 1. Power supply requirements.....	15
Table 2. PLT connections to applications.....	16
Table 3. Jumpers.....	20
Table 4. PLT User Interface application executables.....	25
Table 5. Executables folder description.....	25
Table 6. Production Line Tool Prerequisites.....	28
Table 7. Minimum system requirements.....	28
Table 8. Opening the PLT Visual Studio 2017 Express source code solution.....	29
Table 9. SmartBond_PLT_CFG.exe application execution.....	32
Table 10. SmartBond_PLT_GUI.exe application execution.....	34
Table 11. SmartBond_PLT_CLI.exe application execution.....	36
Table 12. GU_fw_upgrade.exe application execution.....	36
Table 13. DA1459x test sequence.....	38
Table 14. Custom memory data input modes.....	43
Table 15. CFG PLT Main menu options.....	49
Table 16. CFG PLT Bottom Strip options.....	49
Table 17. Station identification.....	51
Table 18. Device IC.....	51
Table 19. Active DUTs.....	52
Table 20. DUT COM Ports.....	52
Table 21. Set the GU COM port.....	53
Table 22. Golden Unit Firmware Version Upgrade.....	53
Table 23. VBAT/Reset mode.....	54
Table 24. Statistics.....	54
Table 25. Test options.....	55
Table 26. BD Address Assignment - Standard mode.....	57
Table 27. BD Address Assignment options - Range mode.....	58
Table 28. BD Address Assignment options - Load from File mode.....	58
Table 29. UART Baud Rate.....	59
Table 30. XTAL Trim.....	60
Table 31. GPIO Watchdog Operation.....	61
Table 32. Scan DUT Advertise Test.....	61
Table 33. Golden Unit RF Tests.....	62
Table 34. BLE Tester General Settings.....	63
Table 35. BLE Tester TX Power.....	64
Table 36. BLE Tester Frequency Offset.....	65
Table 37. BLE Tester Modulation Index.....	66
Table 38. BLE Tester RX Sensitivity.....	67
Table 39. Path Losses per DUT from RF Tests Options.....	68
Table 40. GPIO/LED Tests.....	68
Table 41. GPIO Connection Test.....	69
Table 42. Sensor Tests.....	71
Table 43. Custom Tests Options.....	72
Table 44. External 32 kHz Tests options.....	72
Table 45. Current Measurement Tests.....	74
Table 46. Current Measurement Test – Peripheral Current Measurement.....	74
Table 47. Current Measurement Test - Sleep Current Measurement.....	75
Table 48. Temperature Measurement Test.....	77
Table 49. Scan Test options.....	77
Table 50. QSPI Flash Erase.....	78
Table 51. Flash Image Write.....	79
Table 52. Memory Read test.....	80
Table 53. Custom Memory Data.....	80
Table 54. Configuration Script commands.....	82
Table 55. Configuration Script.....	83

SmartBond Production Line Tool

Table 56. Debug Settings	85
Table 57. Security options	86
Table 58. GUI PLT Main window description	87
Table 59. GUI PLT settings	90
Table 60. CLI commands	97
Table 61: CLI example	101
Table 62. PLT example usage	108
Table 63. RF Test RSSI results.....	122
Table 64. Prerequisites.....	124
Table 65. RF path losses calibration setup	125
Table 66. Procedure steps	127
Table 67. FTDI DialogSemi serial number	135
Table 68. DA1459x Pro DK to PLT connections	140
Table 69. User Interface shortcut keys.....	143
Table 70. DA1459x supported QSPI/QSPI Flash memories.....	144
Table 71. MT8852B Supported Command Codes	145
Table 72. MT8852B – Bluetooth® LE TX output power test results	145
Table 73. MT8852B – Bluetooth® LE carrier frequency offset and drift test results	146
Table 74. MT8852B – Bluetooth® LE modulation characteristics test results	146
Table 75. MT8852B – error list.....	147
Table 76. CSV file contents	150
Table 77. Example CSV log file content analysis.....	154
Table 78. DUT status codes	158
Table 79. Golden Unit status codes	166

1 Terms and Definitions

API	Application Programming Interface
BD	Bluetooth Device
.bin	Firmware files in binary format
Bluetooth® LE	Bluetooth® Low Energy
CFG	Configuration
CLI	Command Line Interface
COM	Communication Port
CPLD	Complex Programmable Logic Device
CRC	Cyclic Redundancy Check
CS	Configuration Script
CSV	Comma Separated Values
DLL	Dynamic Link Library
DMA	Direct Memory Access
DMM	Digital Multi-Meter
DTM	Direct Test Mode (as specified by the Bluetooth® LE Core standard)
DUT	Device Under Test
DVM	Digital Voltage Meter
EEPROM	Electrically Erasable Programmable Read-Only Memory
EFLASH	Embedded Flash
.exe	Executable file
FTDI	Future Technology Devices International Ltd.
GPIO	General Purpose Input-Output
GU	Golden Unit
GUI	Graphical User Interface
Hex	Firmware file in ASCII format
IC	Integrated Circuit
IDE	Integrated Development Environment
I2C	Inter-Integrated Circuit
JTAG	Joint Test Action Group
OQSPI	Octal/Quad SPI Flash
OS	Operating System
OTP	One-Time Programmable (memory)
PC	Personal Computer
PCB	Printed Circuit Board
PER	Packet Error Rate
PLT	Production Line Tool
PLTD	Production Line Tool DLL
POR	Power-On Reset
RAM	Random-Access Memory
RCX	Resistor Crystal Oscillator
RF	Radio Frequency
RX	Receive
SCPI	Standard Commands for Programmable Instruments
SoC	System-on-Chip

SmartBond Production Line Tool

SDK	Software Development Kit
SPI	Serial Peripheral Interface
TCS	Trim and Calibration Section
TX	Transmit
UART	Universal Asynchronous Receiver/Transmitter
UI	User Interface
USB	Universal Serial Bus
VISA	Virtual Instrument Software Architecture
VPP	Programming Supply Voltage (pin)
XML	Extensible Markup Language
XTAL	Crystal
XSD	XML Schema Definition

SmartBond Production Line Tool

2 References

- [1] UM-B-040, DA1458x/DA1468x Production Line Tool Libraries v4.2, User manual, Renesas Electronics.
- [2] [DA14592 Multi-Core BLE 5.2 SoC with Embedded Flash](#), Datasheet, Renesas Electronics.
- [3] UM-B-167 [DA1459x PRO-Development Kit](#), User Manual, Renesas Electronics.
- [4] FTDI Chip, [FT4232H – Hi-Speed Quad USB UART IC](#).
- [5] FTDI Chip, [FT232 – USB UART IC](#).
- [6] Anritsu MT8852B, <https://www.anritsu.com/en-US/test-measurement/products/mt8852b>.
- [7] Keysight 34401A, <http://www.keysight.com/en/pd-1000001295%3Aepsg%3Apro-pn-34401A/digital-multimeter-6-digit?cc=US&lc=eng>.
- [8] Keithley 2000, <http://www.tek.com/tektronix-and-keithley-digital-multimeter/keithley-2000-series-6%C2%BD-digit-multimeter-scanning>.
- [9] Papouch TMU USB thermometer, <https://www.papouch.com/en/shop/product/tmu-usb-thermometer/>.
- [10] NI USB TC-01, <http://sine.ni.com/nips/cds/view/p/lang/en/nid/208177>.
- [11] LitePoint IQxel-M, <http://www.litepoint.com/test-solutions-for-manufacturing/iqxel-m/>.
- [12] Keysight 34461A, <https://www.keysight.com/us/en/product/34461A/digital-multimeter-6-5-digit-truevolt-dmm.html>.

3 Introduction

By using the PLT, it is possible to test, calibrate, and load firmware for 16 different devices under test (DUTs) in parallel.

The following are a list of parts delivered with the tool:

- Hardware
 - Main board (Figure 1) together with a DA14580-QFN48 Golden Unit (GU)
 - Electrical schematics
 - Gerber files
 - Bill of Materials
- Software
 - Source code files organized in a Microsoft® Visual Studio Express 2017 solution
 - Application executables and required DLLs
- Documents.

An example of a sequence of actions the tool performs is given below. All actions are performed in parallel for up to 16 devices.

1. Download the production test firmware.
2. Perform automatic crystal (XTAL) trimming.
3. Perform RF RSSI test.
4. Download and burn the customer firmware (into eFlash, QSPI flash).
5. Burn the CS header.
6. Perform Scan test. Reset the DUTs and set the GU to scan for the DUT Bluetooth® LE advertisements.

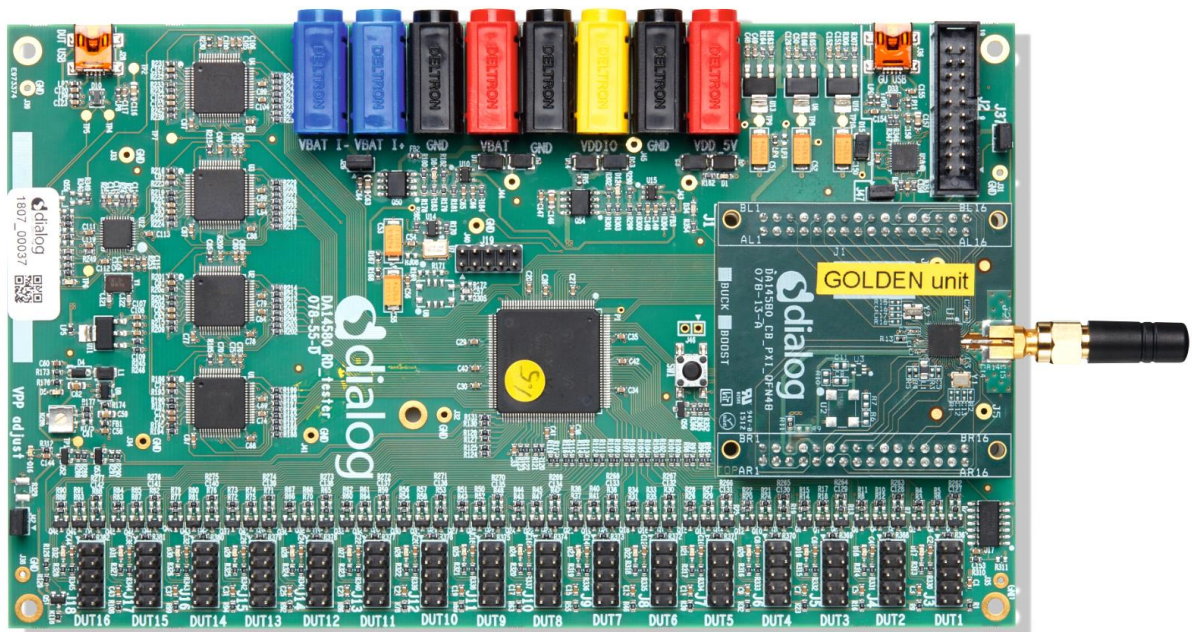

Figure 1. Production Line Tool hardware

4 Hardware

4.1 Hardware block diagram

The Production Line Tool hardware consists of various blocks, as shown in [Figure 2](#). These blocks are explained below.

- **Blue blocks:** USB-to-UART interfaces
 - Four **FT4232 FTDI QUAD** USB-to-UART interfaces are used for a 16-channel USB-to-UART conversion
 - The GU is connected to the PC through an **FT232 FTDI** USB-to-UART interface
- **Red block:** A **CPLD** that has the following purpose
 - Switch UART signals between the PC USB-UART and DUTs
 - Switch DUTs VBAT signal
 - Switch DUTs VPP signal (only when VBAT is enabled)
 - Produce Reset signal to the DUTs
 - Produce very accurate 300 ms or 500 ms XTAL calibration pulse
- **Orange block:** A **Golden Unit** (GU) is mounted, which has the following functionality:
 - CPLD control using custom commands
 - Transceiver for Bluetooth RF signals to and from the DUTs
 - Produce an audio tone using PWM, used for audio testing
 - Scan for device Bluetooth® LE advertisements, after the customer firmware is programmed
- **Purple blocks:** Sixteen (16) device connectors

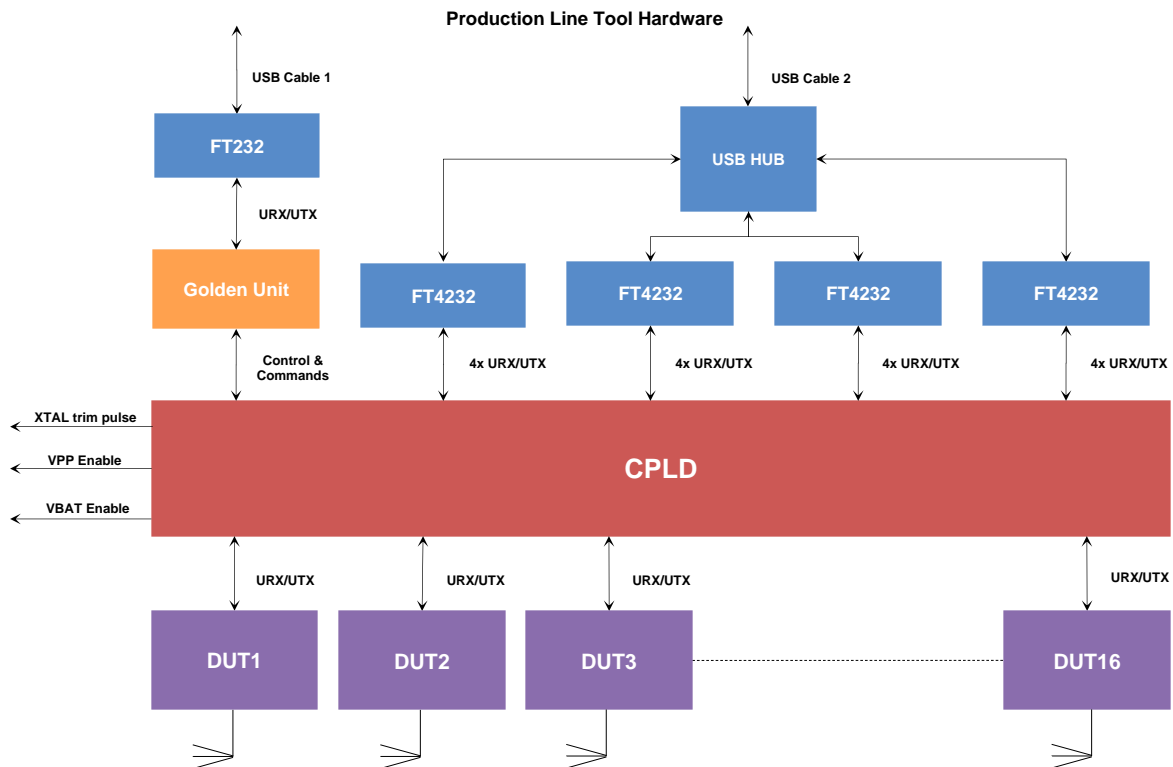

Figure 2. Production Line Tool hardware board block diagram

SmartBond Production Line Tool

4.2 Printed circuit board layout

Figure 3 shows the top view of the PLT board. The important parts are pointed by the orange boxes. The VPP jumper and the Current jumper are colored in blue.

The Golden Unit has a DA14580 QFN48-die soldered. Most of the 48 pins are used to connect to the CPLD. The CPLD is programmed during the production of the PLT board through the CPLD socket. No need to use the CPLD socket.

The black banana sockets are all connected to the same ground (GND) plane.

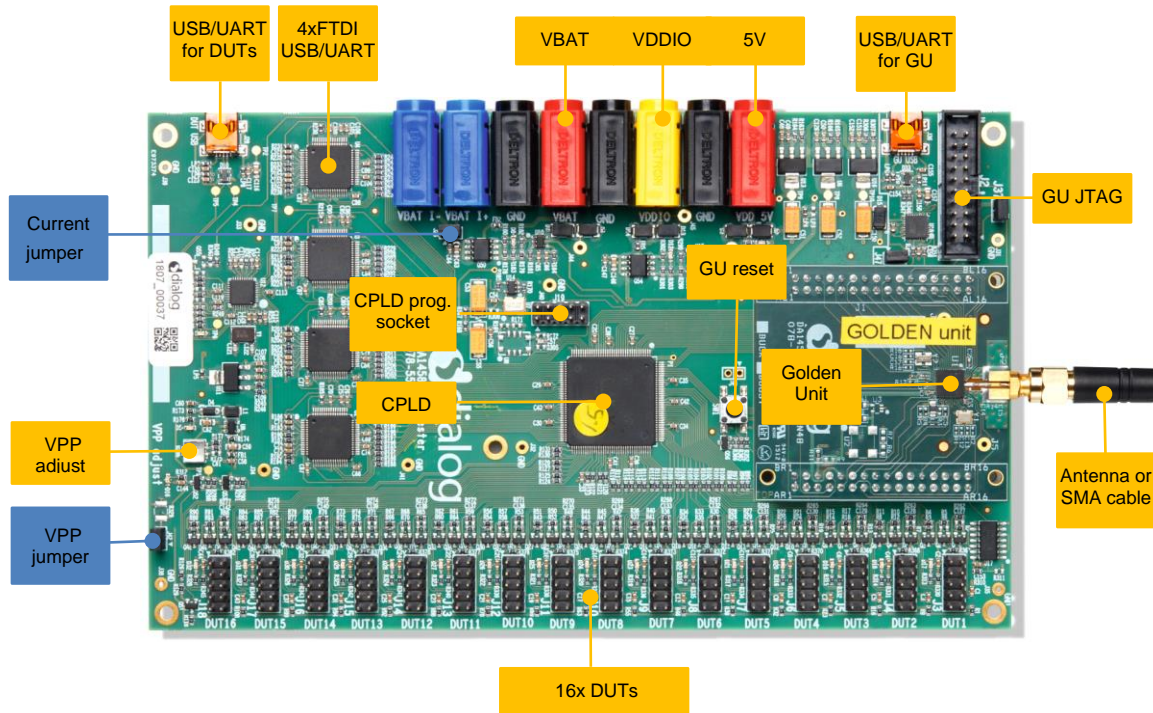

Figure 3. Top view of the PLT hardware board

SmartBond Production Line Tool

4.3 PLT power supply

External power supply is needed for the PLT to run. This should be connected to the banana sockets shown in Figure 4.

Table 1 shows the voltage and current requirements for each power supply. The blue banana sockets can be used for device current measurements.

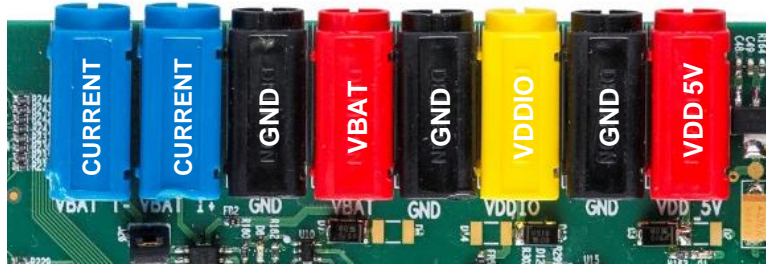

Figure 4. PLT hardware power connections

Table 1. Power supply requirements

Power supply	Voltage (V)	Current (mA)	
		Buck mode	Boost mode
VBAT (Buck mode)	2.4 ... 3.3	16 x 20	
VBAT (Boost mode)	1.5 ... 3.3		16 x 20
VDDIO	2.4 ... 3.3	70	70
VDD 5V	4.75 ... 5.25	~335	~335
VPP	6.6 ... 6.8	16 x 2	16 x 2

4.4 DUT connector

The Bluetooth® LE devices are connected to the PLT using the DUT1-16 connectors at the edge of the PLT board. Figure 5 shows the pin-header connections from the Production Line Tool hardware board to the DUTs. Table 2 describes the purpose of each pin.

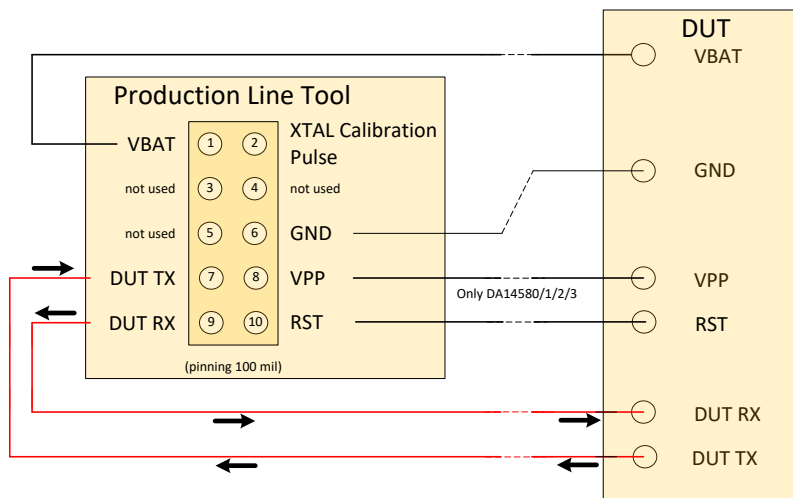

Figure 5. Production Line Tool DUT connections

Table 2. PLT connections to applications

Header pin	Name	Description
1	VBAT	Depending on the VBAT/Reset Signals Operation mode (Section 5.9) this can be used as Voltage supply for the DUT. Due to this connection, no external power supply is needed for the DUTs. This pin must be connected if there is no other power supply (for example, battery).
2	XTAL Calibration Pulse	This pin can be used as a reference pulse during automatic crystal calibration. For more details, see Section 6.2.6.3. The crystal trim pulse can also be supplied in the UART RX device pin. This is the recommended scenario. However, there may be hardware limitations where the UART RX pin cannot be used. In such cases, the particular PLT header pin should be used.
6	GND	Ground pin. This pin must be connected.
7	DUT TX	This is connected to the device UART TX pin. This pin must be connected.
8	VPP	Not used for DA1459x.
9	DUT RX	This is connected to the device UART RX pin. This pin can also provide the crystal calibration reference pulse for the automatic crystal (XTAL) trim procedure, as described in Section 6.2.6.3. This pin must be connected.
10	RST	The reset signal must be connected mostly if battery powered devices are used. A power cycle of VBAT produces a Power on Reset (POR) in which case the RST-wire is not needed. However, using the RST signal is faster, whereas VBAT POR needs time to discharge.

4.5 Data streaming

Figure 6, Figure 7, and Figure 8 show the three possible data streams through the CPLD. The CPLD switches S1, S2, S3, and S4 are controlled by the software through the Golden Unit.

4.5.1 Normal operation

- UART-RxD data** is transported through the RED arrows (AA):
 PC → USB → USB HUB → Quad UART → CPLD signal 'AA' → DUT RxD (programmed as Rx/D).
- UART-TxD data** is transported through the BLUE arrows (BB):
 PC ← USB ← USB HUB ← Quad UART ← CPLD signal 'BB' ← DUT TxD.

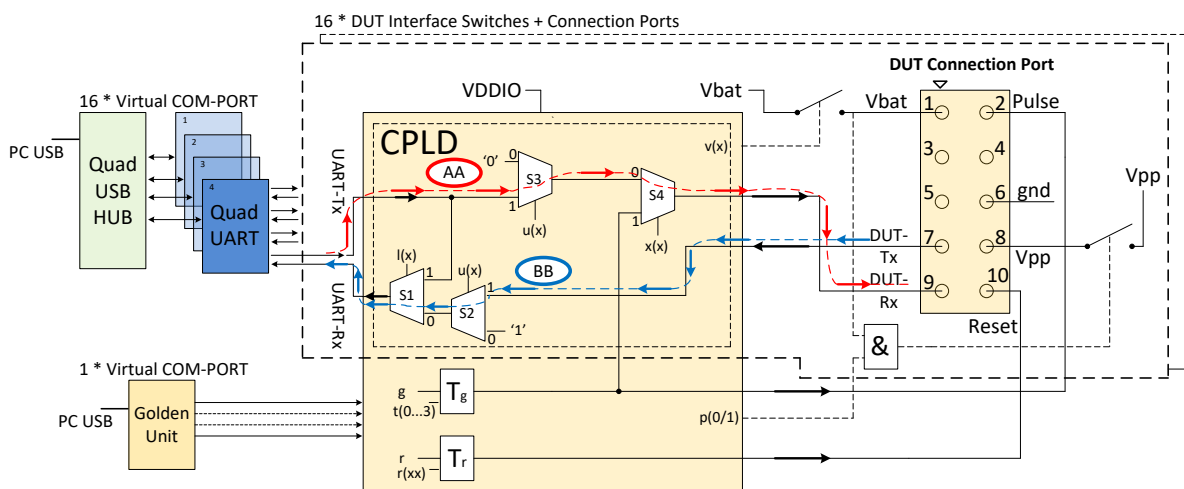

Figure 6. CPLD UART data streams

SmartBond Production Line Tool

4.5.2 Crystal trimming

- **The XTAL calibration pulse** (300 ms or 500 ms) is transported through the PURPLE arrows (CC):
CPLD TIMER $T_g \rightarrow$ CPLD S4 \rightarrow DUT RxD (programmed as GPIO).
- **UART-TxD data** is transported through the BLUE arrows (BB):
PC \leftarrow USB \leftarrow USB HUB \leftarrow Quad UART \leftarrow CPLD signal 'BB' \leftarrow DUT TxD.

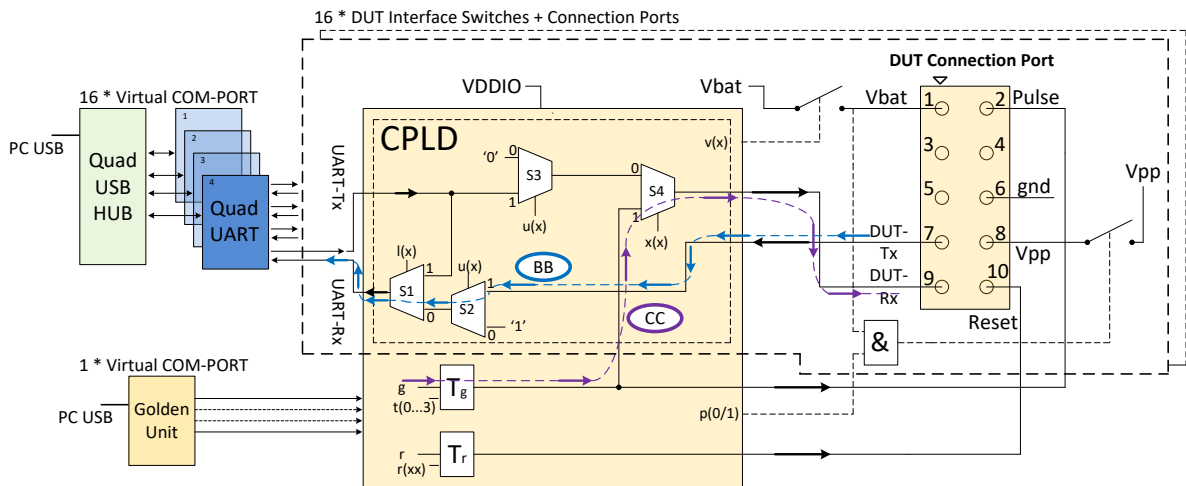

Figure 7. CPLD XTAL trim pulse data stream

4.5.3 Loopback operation

Loopback operation is used during the start of the tests. The PLT software uses this feature to automatically find the numbers of the Virtual COM ports in the Windows PC.

- **The UART loopback data** is transported through the GREEN arrows (DD):
PC \rightarrow USB \rightarrow USB HUB \rightarrow Quad UART \rightarrow CPLD signal 'DD' SW1 \rightarrow Quad UART \rightarrow USB HUB \rightarrow USB \rightarrow PC.

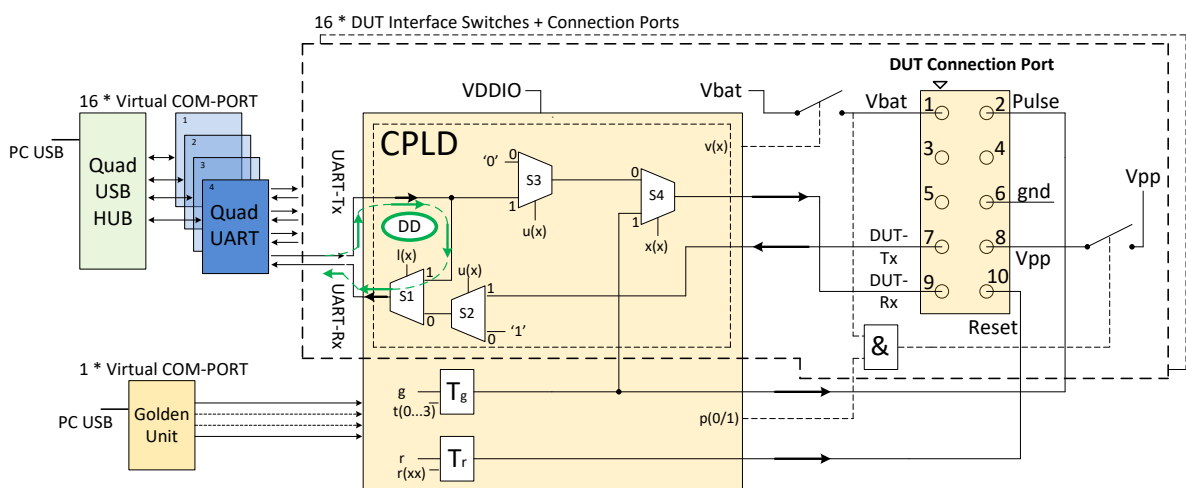

Figure 8. CPLD UART loopback data stream

SmartBond Production Line Tool

NOTE

The CPLD is also used to switch the UART signals between the QUAD FTDIs and the DUTs. When the VBAT is switched off and the UART wires are not disconnected, a "rest voltage" may be present on the product. This could cause problems with the power-on reset (POR) and the product might not boot correctly. The CPLD switches off the UART signals when the VBAT is not present.

4.6 Golden Unit

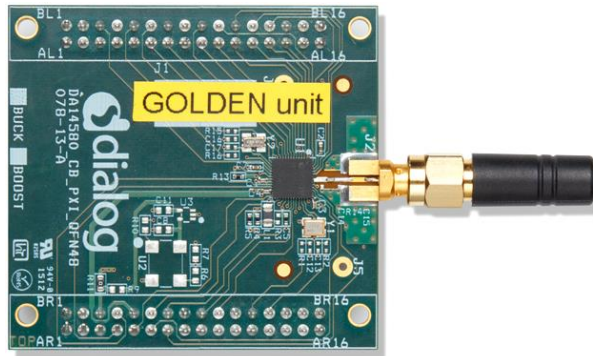

Figure 9. Golden Unit

The Golden Unit (GU) is a daughter board mainly used in the DA1458x Expert Development Kit Ref [2]. In the PLT, the GU is used for various purposes:

- RF transmitter for the RF RSSI DUT test
- RF receiver for the device Bluetooth® LE advertisement scan test
- Audio tone generator for the audio test (not supported in DA1459x family of products)
- Controlling the CPLD.

The GU uses an SPI Flash memory mounted on the PLT board. The SPI Flash is pre-programmed with specific production test firmware. If required, there are several ways to upgrade the GU firmware, either through the PLT's GU JTAG connector, through the UART, or using the GU application executable (GU_fw_upgrade.exe) as explained in Section 6.5. The latest GU firmware can be found inside the latest PLT software release, under the executables\binaries\GU folder.

NOTE

- PLT v4.3 and onwards requires the latest firmware version of the Golden Unit. If the Golden Unit firmware is not updated, then the PLT applications do not run.
- The Golden Unit is calibrated during PLT production. It is delivered with a calibration characterization document.

4.6.1 GU reset

The Golden Unit includes a hardware reset circuit. The GU reset signal is connected to an FTDI FT232 GPIO pin.

Figure 10 shows the electrical schematics of the GU reset circuit. Section 4.8.2 describes the jumper positions on the PLT PCB.

The red line is the connection between the FTDI IC GPIO pin (DTR) and the GU reset signal on the PLT GU connector header. The PLT software controls this pin through the FTDI DLL driver ftd2xx.dll. Making pin DTR low for a short period of time resets the GU. Every time the PLT tests start, a hardware reset is issued to the Golden Unit. Jumper J47 should be ON and J46 OFF for this reset method to operate.

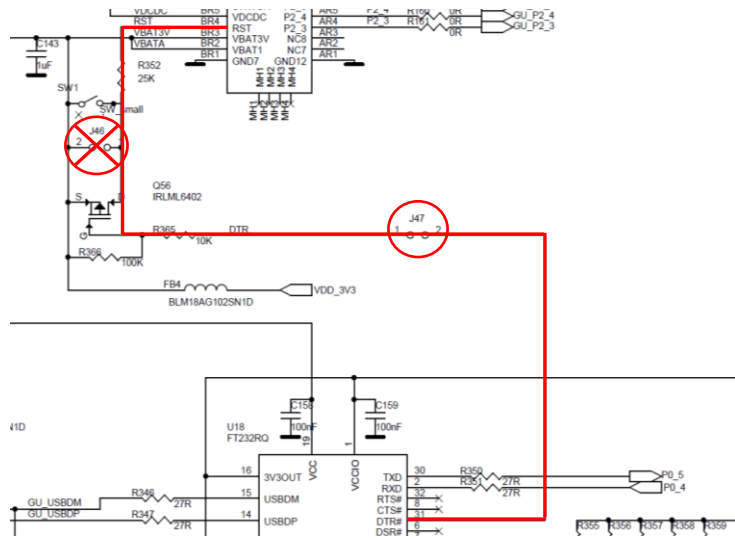

Figure 10. GU reset circuit

4.7 Current measurements

The PLT board provides connections to perform DUT current measurements (Figure 11). By connecting a current meter to the blue banana sockets, the combined VBAT current of all DUTs can be measured. Jumper J26 should be removed when a current meter is connected. If no current meter is used, jumper J26 should be mounted. See also Section 4.8.

The connection shown in Figure 11 can only be used with the VBAT Only (Section 5.9.1) and VBAT On with Reset (Section 5.9.2)(when the VBAT lines are used to power the DUTs) modes. If the DUTs are powered using a single external power supply, then the multi-meter should be connected on that power supply in a similar way as described before with the PLT. If the DUTs are powered independently (for example, each one with its own battery) the current measurement procedure cannot be used.

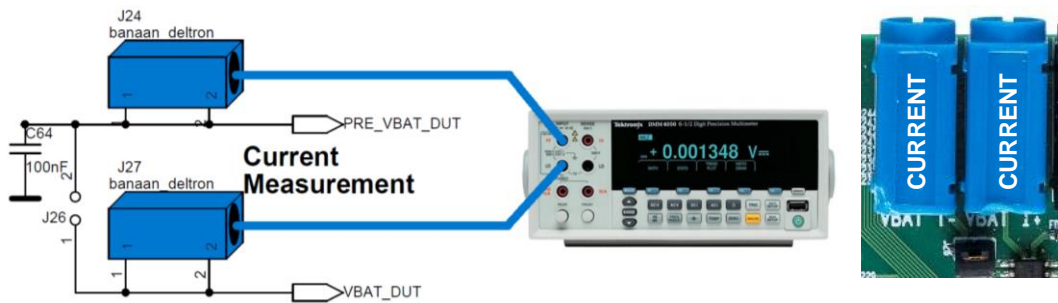

Figure 11. VBAT DUT current measurement setup

4.8 Jumper settings

This section describes the PLT hardware jumper settings.

Table 3. Jumpers

Jumper	PLT hardware version	Description
J26	A, B, C, D	Connects the VBAT line from the PLT power supply to the DUTs. This jumper can be used when there is no multi-meter instrument connected for current measurement.
J37	B, C, D	This jumper sets the Golden Unit's SPI Flash chip select (CS) pin to high. This jumper is placed when the Golden Unit should NOT boot from the SPI flash.
J42	B, C, D	Feeds the VPP lines of the DUT connectors with VPP voltage used for OTP burning in DA14580/1/2/3 DUTs.
J46	C, D	This jumper can be used to reset the Golden Unit. The two pins on the jumper are the same as the ones in the GU reset switch next to the jumper.
J47	D	This jumper connects the Golden Unit's FTDI DTR line to the Golden Unit's reset pin. With this jumper on the PLT, software can reset the Golden Unit on-demand.

4.8.1 J26 - current measurements

As shown in [Figure 12](#), jumper J26 should be mounted when no external current meter is attached. Otherwise, when a current meter is connected through the blue banana sockets to measure the device current, the J26 jumper should be removed.

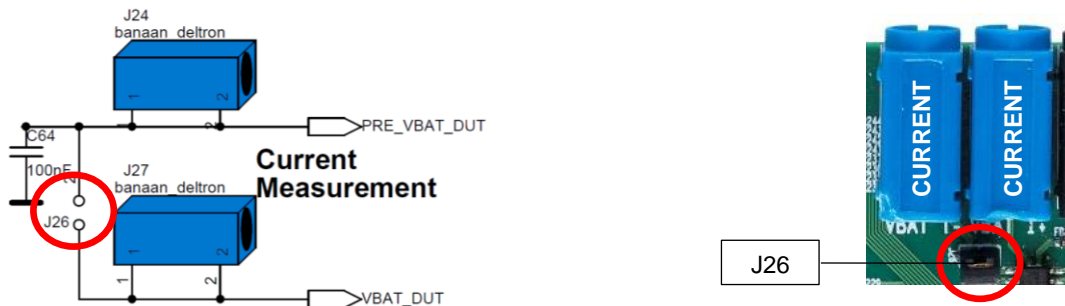

Figure 12. Connections for "Floating Current" measurements

4.8.2 J47, J46 - GU reset

For a GU hardware reset, jumper J47 should be mounted and jumper J46 should be removed. These two jumpers are involved in the circuit shown in [Figure 10](#). In this way, the PLT software controls the GU hardware reset. [Figure 13](#) shows the jumper placement on the actual PCB.

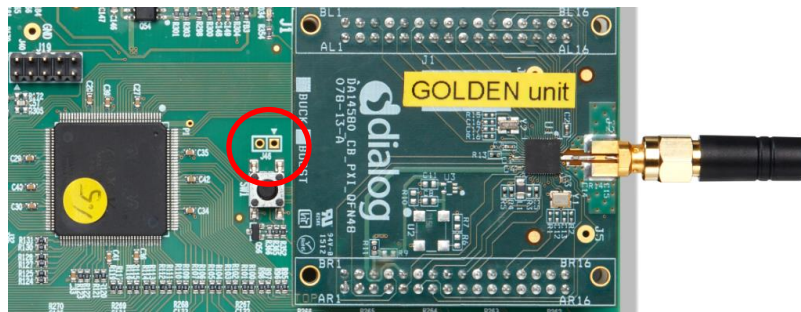

Figure 13. Location of J46 jumper



Figure 14. Location of J47 jumper

4.8.3 J37 - GU programming

Jumper J37 connects the Chip Select of the GU SPI Flash to a logic high level. This causes the GU not to boot from the already programmed SPI Flash, allowing the GU to load different code into its System-RAM through the JTAG connector or through UART. Figure 15 shows the circuit schematic and Figure 16 shows the location of jumper J37 on the PLT PCB.

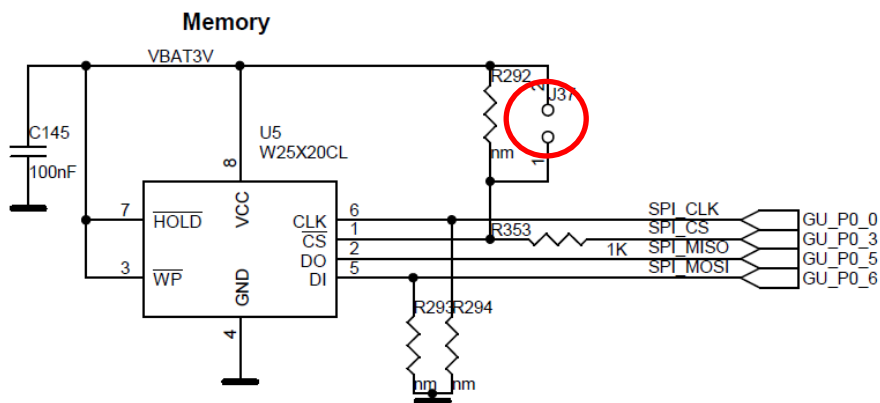

Figure 15. J37 - GU programming jumper schematics

SmartBond Production Line Tool



Figure 16. Location of J37 jumper

4.9 PLT functional blocks

Figure 17 shows an overview of the PLT hardware functions. For detailed electrical schematics, see Appendix B.

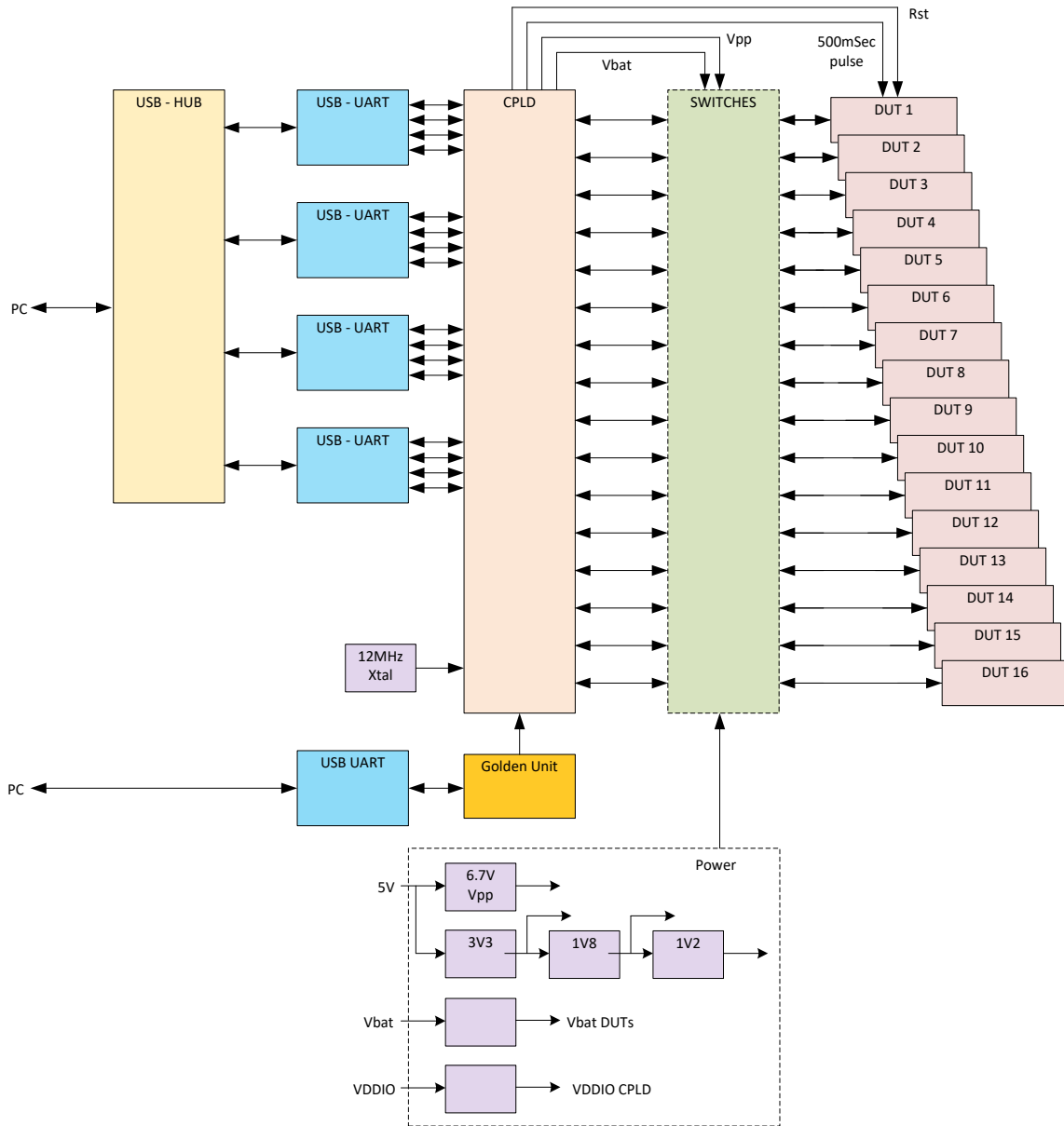

Figure 17. PLT functional blocks

5 Software

5.1 Introduction

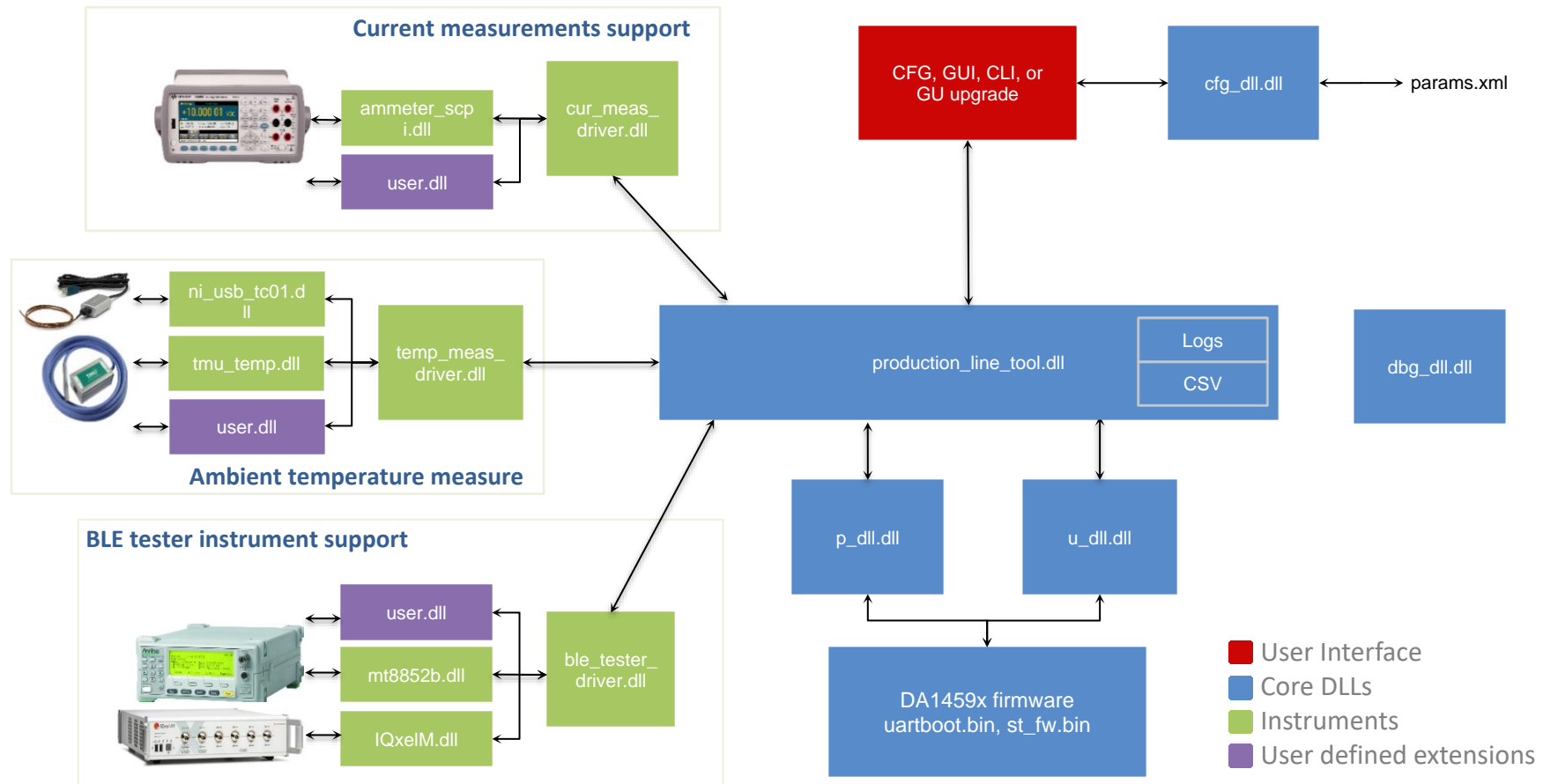

Figure 18. Production Line Tool software block diagram

SmartBond Production Line Tool

The Production Line Tool software is a collection of software blocks that interact with each other, as shown in [Figure 18](#). Its main purpose is to communicate with the PLT hardware and the DUTs to be able to run the production tests and perform memory operations. The software blocks can be arranged in four main groups:

- **Red blocks:** User Interface (UI) applications
- **Blue blocks:** Core libraries
- **Green blocks:** Instrument interface libraries
- **Purple blocks:** User defined extensions.

Core libraries, instrument interface libraries and user-defined extension APIs can be found in the HTML help inside the source PLT directory. The User Interface applications block consists of four application executables. For details, see [Section 6](#).

Table 4. PLT User Interface application executables

Short name	File name	Description
CFG PLT	SmartBond_PLT_CFG.exe	Configuration application. Load, edit, and save the test parameters and the memory actions to be performed during device testing.
GUI PLT	SmartBond_PLT_GUI.exe	Graphical User Interface (GUI) application. Performs the actual device validation and memory programming. Provides a visual indication of the test results and access to the result logs.
CLI PLT	SmartBond_PLT_CLI.exe	The same as the GUI PLT but console based.
GU upgrade	GU_fw_upgrade.exe	A Graphical User Interface (GUI) application, which is used to easily upgrade the firmware of the Golden Unit.

5.2 Software package contents

The PLT software release package comes in a compressed folder `SmartBond_PLT_v_X.X.zip`, where 'X' represents the version number of the current PLT release.

[Figure 19](#) shows the main folders of the PLT software package. Folder `executables` holds all the executables and libraries needed for the PLT to run on a Windows 7/8/8.1/10 machine. Folder `source` contains the entire source code of the PLT, organized in a Visual Studio Express 2017 solution.

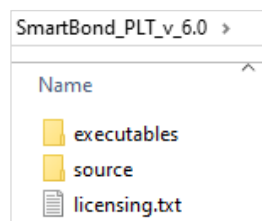

Figure 19. SmartBond PLT software package contents

[Table 5](#) gives a short description of the files and folders contained in the `executables` directories.

Table 5. Executables folder description

File or folder	Description
<code>ammeter_instr_plugins/</code>	Contains the current measurement instrument DLLs, used during the current measurement tests.

SmartBond Production Line Tool

File or folder	Description
ammeter_instr_plugins/ammeter_sspi.dll	This is the DLL for taking current measurements using a DMM that supports the standard SCPI commands. NI-VISA is also used for this purpose. Example DMM instruments are the Keysight 34401A Ref. [7], the Keithley 2000 Ref. [8] or the Keysight 34461A Ref. [12]. The PLT was tested with all three instruments.
binaries/	Contains the necessary firmware binaries used during DUT testing.
binaries/GU/prod_test_GU.bin	Contains the GU latest firmware binary. Users should better upgrade their PLT hardware with the GU firmware contained in this folder.
binaries/GU/flash_programmer_GU.bin	This firmware is used to upgrade the GU firmware by the GU_fw_upgrade.exe application.
ble_tester_instr_plugins/	Contains the Bluetooth® LE tester instrument DLLs.
ble_tester_instr_plugins/mt8852b.dll	This is the DLL that performs the Direct Test Mode RF tests using the Anritsu MT8852B instrument Ref. [6]. Note: There is an issue in Anritsu MT8852B firmware version 4.20.000 and should be upgraded to the latest one. Latest MT8852B instrument firmware can be downloaded from the following link: https://www.anritsu.com/en-US/test-measurement/support/downloads?model=MT8852B
ble_tester_instr_plugins/IQxelM.dll	This is the DLL that performs the Direct Test Mode RF tests using the Litepoint IQxel-M instrument Ref. [11].
icons/	Contains pictures used by the PLT applications.
IQmeasure_3.1.2/	Contains specific Litepoint IQxel-M DLLs as released by Litepoint.
params/	Contains the configuration params.xml file, the XML schema params.xsd and a sample of BD address file named bd_address.ini.
params/custom_mem_data.csv	This is a sample CSV file to be used in the custom memory burn action. Users could edit this file and add their own specific memory data to be burned by the PLT. The PLT matches the entries in the CSV file using the BD addresses. The format of the file is explained later.
scripts/	Contains sample batch script files. User can select batch script files to be executed by the PLT before and after each test.
scripts/run_before_tests.cmd	An example script that copies and renames binaries from a directory to a folder required by the PLT. This folder is accessed by the PLT to read and burn different binaries per DUT.
scripts/run_after_tests.cmd	An example script that moves all logs files, except the ones with the current date, to a specific folder.
temp_meas_instr_plugins/	Contains the temperature measurement instrument DLLs.
temp_meas_instr_plugins/ni_usb_tc01.dll	The ni_usb_tc01.dll is the DLL used to interface a NI USB TC01 Ref. [10] temperature sensor for temperature measurements.

SmartBond Production Line Tool

File or folder	Description
temp_meas_instr_plugins/tmu_temp_sens.dll	The tmu_temp_sens.dll is the DLL used to interface a Papouch TMU sensor Ref. [8] for temperature measurements.
SmartBond_PLT_CFG.exe	This is the configuration application. It is a graphical user interface application used to edit the PLT test configuration parameters, saved in an XML file, params.xml.
SmartBond_PLT_CLI.exe	This is the command line interface tool. It performs the production tests and memory programming through a console.
SmartBond_PLT_GUI.exe	This is the graphical user interface tool. It performs the production tests and memory programming through a graphical user interface.
GU_fw_upgrade.exe	This is the Golden Unit firmware upgrade application.
ammeter_driver.dll/.lib	This DLL loads and accesses all DMM instrument DLLs from inside the ammeter_instr_plugins. It acts as an intermediate layer between the prod_line_tool_dll.dll and the instrument DLLs.
barcode_scanner.dll/.lib	This DLL receives BD addresses from a barcode scanner with USB to serial interface. Tested with Honeywell Xenon 1900 and the Motorola LS2208 barcode scan readers Ref. [1].
ble_tester_driver.dll/.lib	This DLL loads and accesses all Bluetooth® LE tester instrument DLLs from inside ble_tester_instr_plugins folder.
cfg_dll.dll/.lib	This is the configuration parameter handling DLL. It can validate, load, and save parameters from a given XML file.
dbg_dll.dll/.lib	The dbg_dll.dll file is a DLL used to print debug messages to a file or to a debug console.
ftd2xx.dll	This is the FTDI DLL. Used to hard reset the Golden Unit from the application whenever needed through an FTDI GPIO pin.
p_dll.dll/.lib	This is the production test DLL that performs device functional tests.
prod_line_tool_dll.dll/.lib	This is the core DLL. The heart of the system that performs the state machines for all tests and memory actions to be executed. It is responsible to log the results and notify the user interfaces about the current device test status.
temp_meas_driver.dll/.lib	This is the temperature measurement driver DLL. It loads and accesses all temperature measurement DLLs from inside the temp_meas_instr_plugins folder.
u_dll.dll/.lib	This is the DLL that performs the memory actions, like the memory programming, erasing, and so on.
vc_redist.x86.exe/vc_redist.x64.exe	These are the Visual Studio 2017 Express redistributable packages for 32 and 64-bit machines. For installing these, you should agree to the license requirements described during the installation of any of these packages. It is also found here: https://www.visualstudio.com/license-terms/mt171551/ .

SmartBond Production Line Tool
5.3 Prerequisites

Before executing the code, the packages indicated in [Table 6](#) should be installed on the PC. Some are required only if you would like to build the PLT code. Others are optional depending on the tests or actions needed.

Table 6. Production Line Tool Prerequisites

Item	Optional	Description
Visual Studio 2017 Express	Yes	The IDE used to edit and debug the Production Line Tool. This is only required if you would like to edit the software.
vc_redist.x86.exe	No	Already described in Table 5 . You should agree to the license requirements described during the installation of any of these packages. The license file can also be found here: https://www.visualstudio.com/license-terms/mt171551/ .
MSXML6	No	Installed by default in Win 10/11.
.NET framework 4.5	No	Needed for the graphical user interface applications.
Latest FTDI drivers	No	Tested with FTDI v2.12.24, v2.12.26, v2.12.28 and v2.12.36.4 drivers.
NI-VISA 15.5	Yes	Used for optional instrument control, like Bluetooth® LE tester and voltage meter. NI-VISA 15.5 can be downloaded from http://www.ni.com/download/ni-visa-15.5/5846/en/
NI-488.2 15.5	Yes	Used for instrument control, like Bluetooth® LE tester and DMM. NI-488.2 15.5 can be downloaded from http://www.ni.com/download/ni-488.2-15.5/5859/en/
NI-DAQmx	Yes	Used for optional instrument control like temperature measurements using the NI USB TC01 sensor.

5.4 System requirements

[Table 7](#) contains the minimum system requirements for the PLT to operate.

Table 7. Minimum system requirements

Item	Minimum requirements	
Operating system	Windows 10	
CPU	Quad Core CPU	
Memory	4 GB RAM or larger. Each device log can reach up to 40 kB.	
Hard drive	For 100000 devices, at least 4 GB of available hard disk is required.	
Monitor resolution	1280 x 768 or higher	
Monitor DPI	Smaller – 100% = 96 DPI	Supported
	Medium – 125% = 120 DPI	Supported
	Larger – 150% = 144 DPI	Not supported

SmartBond Production Line Tool

5.5 Limitations

Parallel control of multiple PLT hardware boards on the same PC is **not supported**.

However, by correctly setting up the system, two or more PLT hardware boards could be connected and controlled by multiple GUI PLT application instances on the same PC, but the tests should only be executed **sequentially**. The main reasons for this limitation are indicated below:

- The GU FT232 FTDI IC is programmed with a special serial string, `DialogSemi` (see [Table 67](#)). This is used in the `GU COM port find` PLT operation. This operation searches all PC connected FTDIs to find the serial string `DialogSemi`. When found, it saves it as the `GU COM port` number to be used by the PLT. The `GU COM port find` operation opens and locks, for a short period of time, all Windows COM ports, one by one, even the ones used by the other PLT hardware. If the second GUI PLT application instance is performing test operations at the same time and wants to open its DUT COM ports, the operation may fail.
- When the GUI PLT application starts the test operations, it performs a DUT COM port enumeration. During this process, the GU sets the CPLD in UART loopback mode. It opens all PC COM ports one by one and sends a specific word, while trying to see if it receives it back. During this process, other PLTs may need to work with their DUT COM ports, which may happen to be currently used by the DUT COM port enumeration process of the first PLT.
- GU hardware reset. In every PLT test run a GU HW reset is issued from the PLT software using a specific GU FTDI GPIO pin. To access the GU FTDI, the FTDI API is used from `ftd2xx.dll`. To access the FTDI hardware and read the serial number through the FTDI `ftd2xx.dll` the `FT_Open` API is used on all PC COM ports, one by one. Since `FT_Open` is used in all PC COM ports, conflicts could arise if other PLTs would also like to use these COM ports.
- BD addresses handling. Usually, the PLT automatically sets the DUT BD addresses by increasing them one by one. Special care should be taken to work with multiple PLT hardware and software. Most probably, two different BD address files should be used for each PLT hardware.

5.6 Building the Code

The PLT software release package contains not only application executables for directly performing the tests out of the box, but also the entire source code of the tools. This is organized in a Visual Studio 2017 Express solution.

To open the Visual Studio 2017 Express PLT source code solution the following steps should be executed (see [Table 8](#)).

Table 8. Opening the PLT Visual Studio 2017 Express source code solution

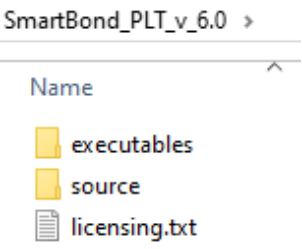
Step	Description
1	Download the latest PLT software package (for example, <code>SmartBond_PLT_v_4.x.zip</code>)
2	Extract the software package. The following two folders should exist. 
3	Go to the <code>source\production_line_tool</code> folder. The following files and folders should exist.

SmartBond Production Line Tool

Step	Description
	<p>SmartBond_PLT_v_6.0 > source > production_line_tool</p> <p>Name ^</p> <ul style="list-style-type: none"> core_dlls fw_files help instruments UI VS2017_redist production_line_tool.sln
4	<p>Double click the <code>production_line_tool.sln</code> Visual Studio 2017 Express solution file. The Visual Studio 2017 Express application starts and the PLT Solution Explorer should be shown.</p>

SmartBond Production Line Tool

Step	Description
	<p>The screenshot shows the Solution Explorer for a solution named 'production_line_tool' containing 19 projects. The structure is as follows:</p> <ul style="list-style-type: none"> core_dlls <ul style="list-style-type: none"> ftdi_dll cfg_dll dbg_dll p_dll prod_line_tool_dll u_dll instruments <ul style="list-style-type: none"> ammeters <ul style="list-style-type: none"> ammeter_driver ammeter_scpi ble_testers <ul style="list-style-type: none"> ble_tester_driver IQxelM mt8852b ni_shims <ul style="list-style-type: none"> ni_daqmx_shim ni_visa_shim temp_sensors <ul style="list-style-type: none"> ni_usb_tc01 temp_meas_driver tmu_temp_sens UI <ul style="list-style-type: none"> common cfg_gui GU_fw_upgrade plt_cli plt_gui
5	<p>To build the code follow the process described in the <i>UM-B-040</i> document Ref. [1].</p> <p>Note: There is no need to unload any projects for the solution to be built. This was fixed in PLT v4.4 and onwards by dynamically linking DLLs.</p>

SmartBond Production Line Tool

5.7 Executing the applications

To execute the Production Line Tool applications, follow the process described in Table 9, Table 10, and Table 11.

Table 9. SmartBond_PLT_CFG.exe application execution

Step	Description
1	Download the latest PLT software package (for example SmartBond_PLT_v_x.x.zip).
2	<p>Extract the software package. The following two folders should exist.</p> <p>SmartBond_PLT_v_6.0 ></p>
3	<p>Go to the executables folder. This folder should contain the following files and sub-folders.</p> <p>> SmartBond_PLT_v_6.0 > executables</p>

SmartBond Production Line Tool

Step	Description																																
4	<p>Double click the SmartBond_PLT_CFG.exe application executable. Most probably, the following warning is shown.</p> <div data-bbox="550 398 1125 651" style="border: 1px solid gray; padding: 10px; margin: 10px auto; width: fit-content;"> <p style="text-align: center;">Warning!!!</p> <p style="text-align: center;"> Failed to load TabPage: {Hardware Setup} settings. ERROR: Value of [gu_com_port] is not valid. </p> <p style="text-align: right; margin-top: 10px;">OK</p> </div> <p>During start-up, the SmartBond_PLT_CFG.exe application loads the Hardware configuration parameters from the params.xml file. These parameters also contain the GU COM port. The default params.xml file has the GU COM port set to 4. If this COM port number does not exist in the PC, then this warning message is shown. Therefore, this warning message indicates that the default GU COM port set in the params.xml file is not valid or that the GU USB cable is not connected to the PC. To exit the warning message, click OK.</p>																																
5	<p>The application starts, and the initial PLT Hardware Setup tab is shown.</p> <div data-bbox="327 936 1220 1809" style="border: 1px solid gray; padding: 10px; margin: 10px auto; width: 90%;"> <p>SmartBond Production Line Tool Configuration - v_6.0</p> <p>File Run</p> <p>PLT Hardware Setup General BD addresses DUT Hardware Setup Test Settings Memory Functions Memory Header Debug S</p> <p>▲ Test Station</p> <p>Station ID <input type="text" value="Test_station_1"/></p> <p>Tester ID <input type="text" value="Tester_1"/></p> <p><input checked="" type="checkbox"/> Ask for Tester ID on start-up</p> <p>▲ Device IC</p> <p>Device IC <input type="text" value="DA14592"/></p> <p>▲ Golden Unit</p> <p>COM Port</p> <p>Set the GU COM port <input type="button" value="Auto"/> <input type="button" value="Refresh"/> <input type="text" value="COM5"/></p> <p>Firmware Version</p> <p>App: <input type="text"/></p> <p>BLE: <input type="text"/></p> <p><input type="button" value="Refresh"/> <input type="button" value="Upgrade GU Firmware"/></p> <p>▲ Active DUTs</p> <table border="0"> <tr> <td><input checked="" type="checkbox"/> DUT 1</td> <td><input type="checkbox"/> DUT 5</td> <td><input type="checkbox"/> DUT 9</td> <td><input type="checkbox"/> DUT 13</td> </tr> <tr> <td><input type="checkbox"/> DUT 2</td> <td><input type="checkbox"/> DUT 6</td> <td><input type="checkbox"/> DUT 10</td> <td><input type="checkbox"/> DUT 14</td> </tr> <tr> <td><input type="checkbox"/> DUT 3</td> <td><input type="checkbox"/> DUT 7</td> <td><input type="checkbox"/> DUT 11</td> <td><input type="checkbox"/> DUT 15</td> </tr> <tr> <td><input type="checkbox"/> DUT 4</td> <td><input type="checkbox"/> DUT 8</td> <td><input type="checkbox"/> DUT 12</td> <td><input type="checkbox"/> DUT 16</td> </tr> </table> <p>▲ DUT COM Ports</p> <table border="0"> <tr> <td>DUT 1 <input type="text" value="28"/></td> <td>DUT 5 <input type="text" value="0"/></td> <td>DUT 9 <input type="text" value="0"/></td> <td>DUT 13 <input type="text" value="0"/></td> </tr> <tr> <td>DUT 2 <input type="text" value="0"/></td> <td>DUT 6 <input type="text" value="0"/></td> <td>DUT 10 <input type="text" value="0"/></td> <td>DUT 14 <input type="text" value="0"/></td> </tr> <tr> <td>DUT 3 <input type="text" value="0"/></td> <td>DUT 7 <input type="text" value="0"/></td> <td>DUT 11 <input type="text" value="0"/></td> <td>DUT 15 <input type="text" value="0"/></td> </tr> <tr> <td>DUT 4 <input type="text" value="0"/></td> <td>DUT 8 <input type="text" value="0"/></td> <td>DUT 12 <input type="text" value="0"/></td> <td>DUT 16 <input type="text" value="0"/></td> </tr> </table> <p>C:\SmartBond_PLT_v_6.0\executables\params\params.xml <input type="button" value="Save"/></p> <p>DA14592</p> </div>	<input checked="" type="checkbox"/> DUT 1	<input type="checkbox"/> DUT 5	<input type="checkbox"/> DUT 9	<input type="checkbox"/> DUT 13	<input type="checkbox"/> DUT 2	<input type="checkbox"/> DUT 6	<input type="checkbox"/> DUT 10	<input type="checkbox"/> DUT 14	<input type="checkbox"/> DUT 3	<input type="checkbox"/> DUT 7	<input type="checkbox"/> DUT 11	<input type="checkbox"/> DUT 15	<input type="checkbox"/> DUT 4	<input type="checkbox"/> DUT 8	<input type="checkbox"/> DUT 12	<input type="checkbox"/> DUT 16	DUT 1 <input type="text" value="28"/>	DUT 5 <input type="text" value="0"/>	DUT 9 <input type="text" value="0"/>	DUT 13 <input type="text" value="0"/>	DUT 2 <input type="text" value="0"/>	DUT 6 <input type="text" value="0"/>	DUT 10 <input type="text" value="0"/>	DUT 14 <input type="text" value="0"/>	DUT 3 <input type="text" value="0"/>	DUT 7 <input type="text" value="0"/>	DUT 11 <input type="text" value="0"/>	DUT 15 <input type="text" value="0"/>	DUT 4 <input type="text" value="0"/>	DUT 8 <input type="text" value="0"/>	DUT 12 <input type="text" value="0"/>	DUT 16 <input type="text" value="0"/>
<input checked="" type="checkbox"/> DUT 1	<input type="checkbox"/> DUT 5	<input type="checkbox"/> DUT 9	<input type="checkbox"/> DUT 13																														
<input type="checkbox"/> DUT 2	<input type="checkbox"/> DUT 6	<input type="checkbox"/> DUT 10	<input type="checkbox"/> DUT 14																														
<input type="checkbox"/> DUT 3	<input type="checkbox"/> DUT 7	<input type="checkbox"/> DUT 11	<input type="checkbox"/> DUT 15																														
<input type="checkbox"/> DUT 4	<input type="checkbox"/> DUT 8	<input type="checkbox"/> DUT 12	<input type="checkbox"/> DUT 16																														
DUT 1 <input type="text" value="28"/>	DUT 5 <input type="text" value="0"/>	DUT 9 <input type="text" value="0"/>	DUT 13 <input type="text" value="0"/>																														
DUT 2 <input type="text" value="0"/>	DUT 6 <input type="text" value="0"/>	DUT 10 <input type="text" value="0"/>	DUT 14 <input type="text" value="0"/>																														
DUT 3 <input type="text" value="0"/>	DUT 7 <input type="text" value="0"/>	DUT 11 <input type="text" value="0"/>	DUT 15 <input type="text" value="0"/>																														
DUT 4 <input type="text" value="0"/>	DUT 8 <input type="text" value="0"/>	DUT 12 <input type="text" value="0"/>	DUT 16 <input type="text" value="0"/>																														

SmartBond Production Line Tool

Step	Description
6	<p>Connect the PLT hardware to the PC. Connect the GU and the DUT USB cables to the PC. Check the Windows Device Manager that 17 new COM ports were found, 16 for the DUTs and 1 for the GU. The following screenshot is an example of a Device Manager COM ports for a PC that has the PLT connected.</p> 
7	<p>To automatically find the GU COM port among the 17 Windows enumerated COM ports, on the Golden Unit pane, in the COM Port section, click Auto. The Auto button turns green if successful. To save the new GU COM port in the <code>params.xml</code> file, click Save*.</p> 

Table 10. SmartBond_PLT_GUI.exe application execution

If you already run the `SmartBond_PLT_GUI.exe` application, start with step 2 to set up the system and test parameters.

Step	Description
1	To successfully start the <code>SmartBond_PLT_GUI.exe</code> application, the <code>SmartBond_PLT_CFG.exe</code> should be executed first to set up the system and perform the required tests. See Table 9 .
2	Go to the <code>executables</code> folder, and then double-click <code>SmartBond_PLT_GUI.exe</code> . This folder should contain the following files and sub-folders.

SmartBond Production Line Tool

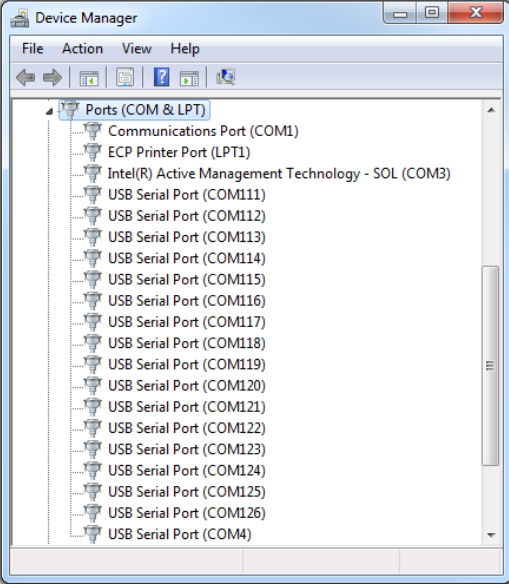
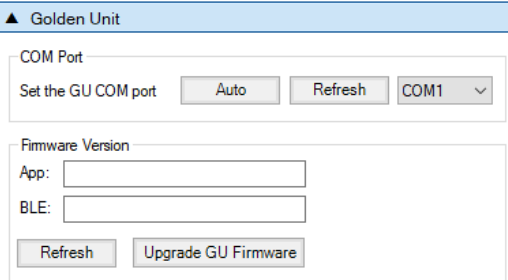
Step	Description
	<p>> SmartBond_PLT_v_6.0 > executables</p>
3	<p>In Tester ID window, enter the Tested ID name, and then click OK.</p>
-	<p>The following initial window appears.</p>
4	<p>Press Spacebar to click the START button and the preconfigured tests and memory actions start to be executed.</p>

SmartBond Production Line Tool

Table 11. SmartBond_PLT_CLI.exe application execution

If you already run the SmartBond_CLI_GUI.exe application, start with step 2 to set up the system and test parameters.

Step	Description
1	To successfully start the SmartBond_PLT_CLI.exe application, the SmartBond_PLT_CFG.exe should be executed first, in order to set up the system and perform the required tests. See Table 9.
2	<p>Go to executables folder . This folder should contain the following files and sub-folders.</p> <pre>> SmartBond_PLT_v_6.0 > executables</pre>
3	<p>Double-click the SmartBond_PLT_CLI.exe application executable. The following initial window appears.</p> <pre>SmartBond Production Line Tool v_6.0 Command list: a <FFFF-0000> --> Bitwise DUT activation. b <xx:xx:xx:xx:xx:xx> --> BD address to be used in the first active DUT of the next PLT test run. c <on/off> --> Graphics enable or disable. d <file> --> Enable Error and Info prints. Printed on file. e --> Exit. g --> GU COM port find. h --> Print this help. i <configuration file path> --> Import new configuration settings. Example: 'i params\params.xml' All DLLs will be reinitialized with the new parameters. l --> GU check by blinking its LED. m <1FFFF-00000> --> MSB=1 Init. Next 16 bits are for bitwise DUT VBAT/UART set/reset. n <'1-SerialNumber1 2-SerialNumber2 ... 16-SerialNumber16'> --> Give DUT serial numbers for logging. p --> DUT COM port enumeration. q <otp/qspi/eflash> <address in hex (otp 0-FFC)><size in decimal> --> Read memory data. Prints up to 14 bytes. s --> Start the tests. t <DA14701/DA14705/DA14706/DA14708> --> Select the IC for device under test. u <9000/19200/57600/115200/1000000/2000000> --> Run the UART check procedure. w <number of tests> --> Command used only for tool evaluation. Runs multiple tests, one after the other, without stopping. x --> Print the configuration parameters from the currently used XML file. z --> Reset all parameters to their defaults.</pre>
4	Type s, then click Enter. The preconfigured tests and memory actions will start to be executed.

Table 12. GU_fw_upgrade.exe application execution

Step	Description
1	To start the GU_fw_upgrade.exe application, open it from the executables folder or, in the PLT Hardware Setup tab in SmartBond_PLT_CFG.exe, click the Upgrade GU Firmware button .

SmartBond Production Line Tool

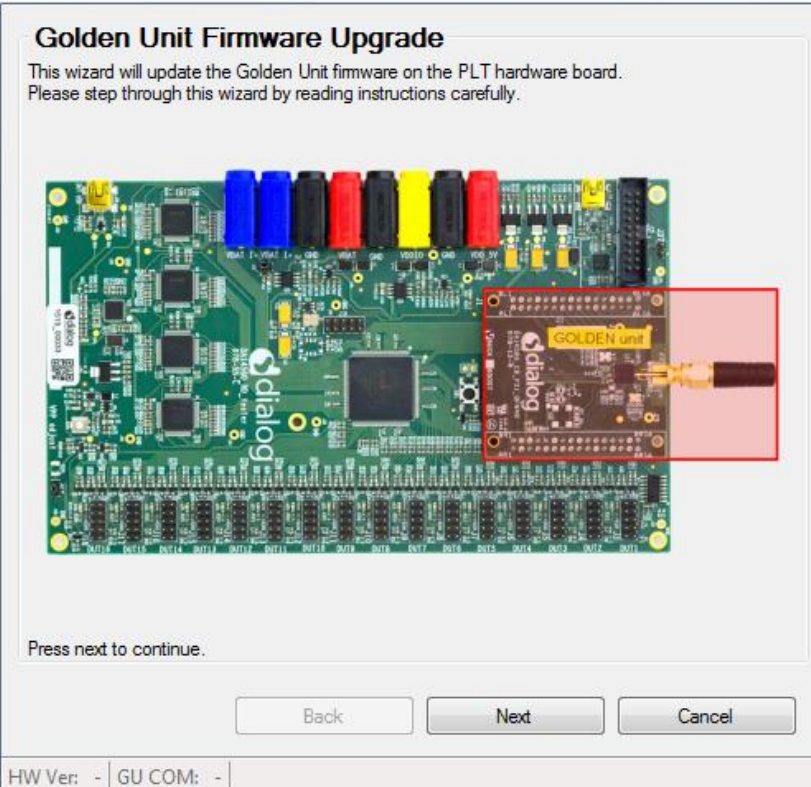
Step	Description																																										
2	<p>Go to the <code>executables</code> folder. This folder should contain the following files and sub-folders.</p> <pre> > SmartBond_PLT_v_6.0 > executables </pre> <table border="1" data-bbox="319 403 1197 940"> <tr> <td>ammeter_instr_plugins</td> <td>vc_redist.x86.exe</td> <td>ammeter_driver.lib</td> </tr> <tr> <td>binaries</td> <td>ammeter_driver.dll</td> <td>barcode_scanner.lib</td> </tr> <tr> <td>ble_tester_instr_plugins</td> <td>barcode_scanner.dll</td> <td>ble_tester_driver.lib</td> </tr> <tr> <td>icons</td> <td>ble_tester_driver.dll</td> <td>cfg_dll.lib</td> </tr> <tr> <td>IQmeasure_3.1.2</td> <td>cfg_dll.dll</td> <td>dbg_dll.lib</td> </tr> <tr> <td>logs</td> <td>dbg_dll.dll</td> <td>ftd2xx.lib</td> </tr> <tr> <td>params</td> <td>ftd2xx.dll</td> <td>ni_daqmx_shim.lib</td> </tr> <tr> <td>scripts</td> <td>ni_daqmx_shim.dll</td> <td>ni_visa_shim.lib</td> </tr> <tr> <td>temp_meas_instr_plugins</td> <td>ni_visa_shim.dll</td> <td>p_dll.lib</td> </tr> <tr> <td>volt_meter_instr_plugins</td> <td>p_dll.dll</td> <td>prod_line_tool_dll.lib</td> </tr> <tr> <td>GU_fw_upgrade.exe</td> <td>prod_line_tool_dll.dll</td> <td>temp_meas_driver.lib</td> </tr> <tr> <td>SmartBond_CFG_PLT.exe</td> <td>temp_meas_driver.dll</td> <td>u_dll.lib</td> </tr> <tr> <td>SmartBond_CLI_PLT.exe</td> <td>u_dll.dll</td> <td>volt_meter_driver.lib</td> </tr> <tr> <td>SmartBond_GUI_PLT.exe</td> <td>volt_meter_driver.dll</td> <td>licensing.txt</td> </tr> </table>	ammeter_instr_plugins	vc_redist.x86.exe	ammeter_driver.lib	binaries	ammeter_driver.dll	barcode_scanner.lib	ble_tester_instr_plugins	barcode_scanner.dll	ble_tester_driver.lib	icons	ble_tester_driver.dll	cfg_dll.lib	IQmeasure_3.1.2	cfg_dll.dll	dbg_dll.lib	logs	dbg_dll.dll	ftd2xx.lib	params	ftd2xx.dll	ni_daqmx_shim.lib	scripts	ni_daqmx_shim.dll	ni_visa_shim.lib	temp_meas_instr_plugins	ni_visa_shim.dll	p_dll.lib	volt_meter_instr_plugins	p_dll.dll	prod_line_tool_dll.lib	GU_fw_upgrade.exe	prod_line_tool_dll.dll	temp_meas_driver.lib	SmartBond_CFG_PLT.exe	temp_meas_driver.dll	u_dll.lib	SmartBond_CLI_PLT.exe	u_dll.dll	volt_meter_driver.lib	SmartBond_GUI_PLT.exe	volt_meter_driver.dll	licensing.txt
ammeter_instr_plugins	vc_redist.x86.exe	ammeter_driver.lib																																									
binaries	ammeter_driver.dll	barcode_scanner.lib																																									
ble_tester_instr_plugins	barcode_scanner.dll	ble_tester_driver.lib																																									
icons	ble_tester_driver.dll	cfg_dll.lib																																									
IQmeasure_3.1.2	cfg_dll.dll	dbg_dll.lib																																									
logs	dbg_dll.dll	ftd2xx.lib																																									
params	ftd2xx.dll	ni_daqmx_shim.lib																																									
scripts	ni_daqmx_shim.dll	ni_visa_shim.lib																																									
temp_meas_instr_plugins	ni_visa_shim.dll	p_dll.lib																																									
volt_meter_instr_plugins	p_dll.dll	prod_line_tool_dll.lib																																									
GU_fw_upgrade.exe	prod_line_tool_dll.dll	temp_meas_driver.lib																																									
SmartBond_CFG_PLT.exe	temp_meas_driver.dll	u_dll.lib																																									
SmartBond_CLI_PLT.exe	u_dll.dll	volt_meter_driver.lib																																									
SmartBond_GUI_PLT.exe	volt_meter_driver.dll	licensing.txt																																									
3	<p>Double-click the <code>GU_fw_upgrade.exe</code> application executable. The following initial window appears.</p> 																																										
4	<p>Follow the instructions to guide you to successfully configure and select the Golden Unit. A detailed procedure is explained in Section 6.5.</p>																																										

SmartBond Production Line Tool
5.8 Test sequence

This section describes the sequence of steps involved for the DA1459x device testing. It outlines all the steps the PLT follows to successfully test a device.

5.8.1 DA1459x test sequence

Table 13 describes each step that the PLT undertakes to validate and program DA1459x-based devices. Some of the steps are optional and are only executed if the equivalent actions are enabled in the configuration parameters.

The entire test sequence for the DA1459x DUTs is shown in Figure 20.

Table 13. DA1459x test sequence

Step	Action	Opt.	Description
1	Statistics update	No	Update the total tests executed.
2	BD addresses	No	Update the BD addresses for all DUTs.
3	Configuration parameters	No	Configuration parameters are passed from the CLI or GUI to the <code>prod_line_tool_dll.dll</code> . If any of the parameters is not valid, an error occurs.
4	Reset GU	No	GU hardware reset by controlling an FT232 pin.
5	Initialize PLT hardware (CPLD)	No	The GU sets the CPLD to an initial known state.
6	Check temperature sensor instrument	Yes	Check whether the temperature measurement instrument is online, only if the temperature measurement test is active.
7	Check Bluetooth® LE tester instrument	Yes	Check whether the Bluetooth® LE tester instrument is online, only if any of the Bluetooth® LE tester test operations is active.
8	Check ammeter instrument	Yes	Check whether the ammeter is online, only if any of the current measurement tests is active.
9	Toggle GU LED	No	Toggle the GU red LED on the PLT hardware to indicate that the GU is alive.
10	Check DUT COM ports	No	Check whether the PLT has identified the DUT COM ports and if not run the automatic DUT COM port identification.
11	Temperature measure	Yes	If the temperature measurement test is active, take a measurement and log it to all DUT logs and in the CSV file.
12	Power-up DUTs	Yes	Provide power to the DUTs so the boot process can start.
13	Download <code>uartboot_da1459x_minimal.bin</code>	Yes	If any of the production tests are active, the <code>uartboot_da1459x_minimal.bin</code> is downloaded so <code>st_fw_da1459x.bin</code> can be downloaded to the system RAM. In addition, if the GPIO watchdog option is enabled, it starts toggling after the <code>uartboot_da1459x_minimal.bin</code> is loaded and right before the production test download.
14	Get <code>uartboot_da1459x_minimal.bin</code> version.	Yes	After <code>uartboot_da1459x_minimal.bin</code> is downloaded, commands can be sent to it. A command to get the <code>uartboot_da1459x_minimal.bin</code> firmware version is sent to the devices.

SmartBond Production Line Tool

Step	Action	Opt.	Description
15	GPIO watchdog	Yes	If the GPIO watchdog option is enabled, then firmware starts the toggling after the <code>uartboot_da1459x.bin</code> is loaded and right before the production test download.
16	Download <code>st_fw_da1459x.bin</code>	Yes	If any of the production tests is active (for example, RF tests, XTAL trim, and so on) download the <code>st_fw_da1459x.bin</code> to the devices.
17	Open the devices COM ports and get the <code>st_fw_da1459x.bin</code> firmware version	Yes	After <code>st_fw_da1459x.bin</code> is downloaded, commands can be sent to it. First, the Windows DUTs COM ports are opened. Then, a command to get the <code>st_fw_da1459x.bin</code> firmware version is sent to the devices. If there is a problem in the firmware or in the device, then this is the first failure to happen. The firmware version get action fails.
18	GPIO watchdog	Yes	If the GPIO watchdog option is enabled, the firmware begins a periodic GPIO toggling during the whole production test procedure.
19	Production timestamp	Yes	PLT reads the IC production timestamp and log it.
20	VBAT level measure	Yes	PLT sends a command to each DUT to measure VBAT for each one, using the internal ADC. VBAT level is logged for debugging purposes.
21	External 32kHz	Yes	Check whether the external 32 kHz crystal operates correctly.
22	XTAL trim	Yes	Perform the XTAL trim procedure if this is active.
23	UART resync	Yes	If the XTAL trim procedure was performed in the UART RX pin, then a special UART resync procedure takes place to resynchronize the device's UART RX path as it may have entered in a baud rate error state due to the 500 ms received XTAL trim pulse.
24	Bluetooth® LE scan (TX test)	Yes	If the Scan DUT Advertise test is active, then perform a Bluetooth® LE scan test using HCI triggered advertisements. DUTs start to advertise with a well-known BD address, one by one. GU scans and returns the RSSI for each DUT.
25	Bluetooth® LE tester TX power	Yes	If the Bluetooth® LE tester TX Power test is active, then perform the test using the external Bluetooth® LE tester instrument.
26	Bluetooth® LE tester TX carrier offset	Yes	If the Bluetooth® LE tester TX carrier offset test is active, then perform the test using the external Bluetooth® LE tester instrument.
27	Bluetooth® LE tester TX modulation index	Yes	If the Bluetooth® LE tester TX modulation index test is active, then perform the test using the external Bluetooth® LE tester instrument.
28	Bluetooth® LE tester RSSI	Yes	If the Bluetooth® LE tester RSSI test is active, then perform the test using the external Bluetooth® LE tester instrument.
29	GU RSSI test	Yes	If the RSSI test using the GU as transmitter is active, then perform the test.
30	GPIO/LED	Yes	Perform the GPIO/LED test, if the test is active.
31	GPIO connection test	Yes	Perform a GPIO continuity or voltage level test if the test is active.

SmartBond Production Line Tool

Step	Action	Opt.	Description
32	Sensor test	Yes	Perform the sensor tests only if these are enabled.
33	Custom test	Yes	Perform any active custom test.
34	Current measure peripheral	Yes	Perform any active current measurement test for peripherals.
35	Current measure sleep	Yes	Perform the sleep current measurement.
36	Power cycle or reset DUTs	Yes	Power cycle with VBAT or Reset DUTs to enter boot procedure.
37	Open COM port and download uartboot_da1459x.bin	Yes	If any of the memory actions is active (for example, QSPI/EFLASH burn, QSPI/EFLASH erase, and so on) download the <code>uartboot_da1459x.bin</code> to the devices.
38	Get <code>uartboot_da1459x.bin</code> version.	Yes	After <code>uartboot_da1459x.bin</code> is downloaded, commands can be sent to it. A command to get the <code>uartboot_da1459x.bin</code> firmware version is sent to the devices.
39	GPIO watchdog	Yes	If the GPIO watchdog option is enabled, the firmware begins a periodic GPIO toggling during the whole memory programming procedure.
40	QSPI memory initialization	Yes	If any QSPI operation is enabled, initialize the memory connected to the appropriate interface.
41	QSPI erase	Yes	Erase the QSPI, either the entire or part of it depending on the configuration.
42	QSPI image write	Yes	If enabled, write the QSPI with the customer image. If verify is enabled, the contents of the QSPI are read back and compared to the original image downloaded.
43	Custom memory data	Yes	Write custom memory data, taken from a barcode scanner, entered manually or through a CVS file.
45	CS write	Yes	If enabled, PLT programs the configuration script area on the EFLASH or QSPI.
46	Memory read	Yes	Up to 10 memory read tests can be performed with up to 256 bytes in length.
47	Power cycle or reset DUTs	Yes	Power cycle with VBAT or Reset DUTs enter boot procedure.
48	Scan test	Yes	If enabled, the GU scans for device Bluetooth® LE advertisements. For the DUTs to be scanned a valid firmware must be burned into the EFLASH or QSPI flash that sends Bluetooth® LE advertisements after power up. Additionally, the BD address should be written in the configuration script by the PLT. The PLT expects to find devices in the air with the BD addresses programmed by the same tool, so it can match the BD addresses returned by the GU.

SmartBond Production Line Tool

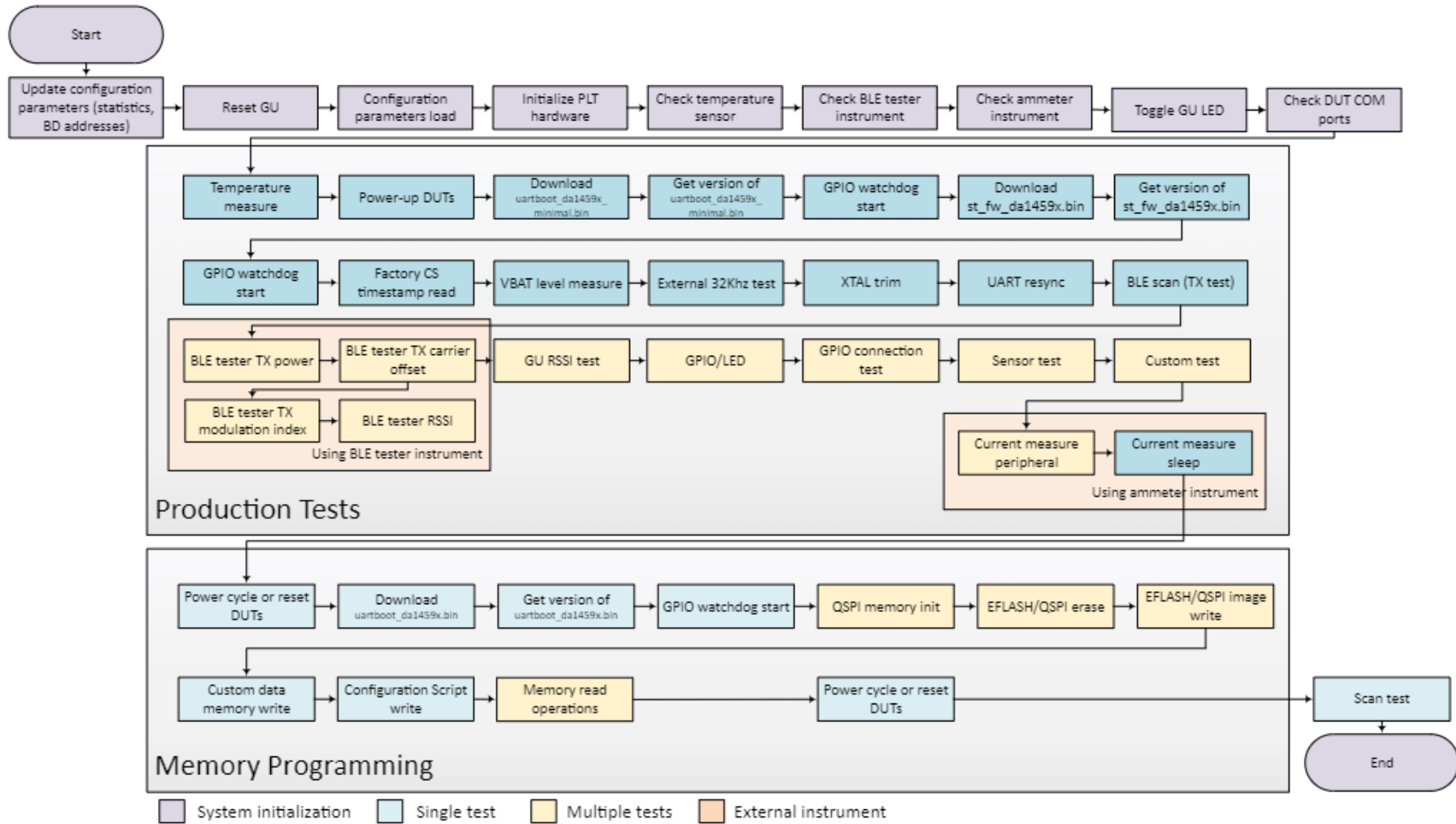

Figure 20. DA1459x test sequence

5.9 VBAT/Reset signals operation

The following section describes the PLT hardware VBAT and Reset signal operation during the DUT test sequence in Section 5.8.

There are two different modes available to power and reset the DUTs using a combination of the PLT VBAT and Reset lines. These are described next.

5.9.1 VBAT Only

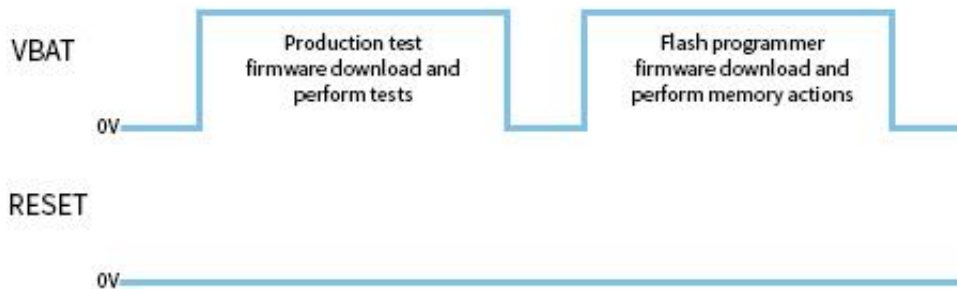

Figure 21. VBAT Only

In this mode only the VBAT line is used, as shown in Figure 21. Only the VBAT signal from the PLT hardware board to the DUT should be connected. The Reset signal is not driven. The DUTs are powered independently from their VBAT lines connected to the PLT hardware and when reset is needed, the PLT software toggles the VBAT line low to perform a POR to each device.

Battery powered DUTs or DUTs with an external power supply are not supported in this mode. PLT to DUT VBAT line connection is mandatory. PLT Reset line connection is not required.

5.9.1.1 Firmware download

When the firmware download procedure begins, the PLT VBAT line powers the DUTs and the UART connections open. This results in a POR for all active devices. The POR activates the DUTs UART booting procedure and the PLT software is able to download the test firmware.

If there are devices that failed the test firmware download procedure, PLT performs a VBAT POR to retry the firmware download procedure only for those that failed. During the extra attempts to download firmware to the failed devices, the VBAT lines of the devices that succeeded remain active. After maximum of three retry attempts, the PLT VBAT lines remain active only for the devices that succeeded. You can configure the retry operation and the number of retries. For more details, see Section 6.2.3.2.

When the production testing is finished the above procedure is repeated for the memory programming, as a different firmware needs to be downloaded to the DUTs.

5.9.1.2 Current measurement

Since the DUTs are powered through the PLT hardware using the VBAT line, the Current Measurement Test (Table 45) for the DA1459x are supported as described in Section 4.7.

SmartBond Production Line Tool

5.9.2 VBAT On with Reset

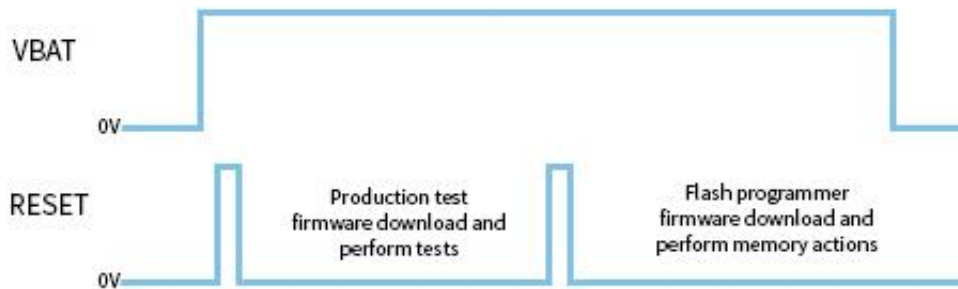

Figure 22. VBAT On with Reset

In VBAT On with Reset mode the reset of the DUTs is performed by the PLT Reset line as shown in Figure 22. During this mode, the PLT VBAT line continuously provides power to the DUTs and the DUTs are reset using the PLT Reset line.

Power supply can be provided to the DUTs if the PLT VBAT line is connected to the DUTs. However, for battery powered DUTs or for DUTs with an external power supply, VBAT should not be connected. For such devices, only the connection to the PLT Reset line is mandatory.

5.9.2.1 Firmware download

When the firmware download procedure begins, PLT resets the DUTs using the PLT Reset line. The VBAT line is already active and remains active for the entire PLT test and memory programming procedure. If there are devices that failed to download firmware, the PLT resets all the DUTs again and retry to download firmware to all of them even if these have succeeded. This is different approach from the VBAT Only procedure (Section 5.9.1), because the Reset line is a single hardware line that cannot be differently controlled for each DUT, as opposed to the VBAT lines. You can configure the retry operation and the amount of retries, see Section 6.2.3.2.

When the production testing is finished, the above procedure is repeated for the memory programming, as a different firmware needs to be downloaded to the DUTs.

5.9.2.2 Current measurement

If the DUTs are powered through the PLT hardware using the VBAT line, or if they are powered using a single common line from an external power supply, the Current Measurement Test (Table 45) for the DA1459x are supported as described in the Section 4.7. If the DUTs are powered independently or have their own power supply (for example, have a battery) then the current measurement tests are not supported.

5.10 Custom memory data

The following section describes the PLT Custom Memory Data configuration and programming procedure.

The PLT supports programming custom user data of any size up to 256 bytes, to any memory and from any start address. Custom data can be entered to the PLT by the three input methods described in Table 14.

Table 14. Custom memory data input modes

Input modes	Description
CSV file	You can provide a path to a CSV file that contains the custom memory data for each DUT. The format of the CSV file is specific and provided in Section 5.10.1.

SmartBond Production Line Tool

Input modes	Description
Manual	You can manually edit the custom memory data prior of each PLT test run. The edit can be done in the PLT GUI or in the <code>params.xml</code> file using an external application or script. If different data per DUT is required, then the update of the custom memory data should be done before every PLT test run.

For the detailed explanation of the various configuration parameters of the Custom Memory Data programming PLT feature, see Section 6.2.8.1.

5.10.1 Custom data CSV file format

This section describes the format of the CSV file used in CSV File Input mode of the Custom Memory Data test (Section 5.10).

	A	B	C	D	E	F	G	H	I	J
1	00:00:00:11:22:33	EFLASH	E10000	16	11223344556677889900AABBCCDDEEF1					
2	00:00:00:11:22:34	EFLASH	E10000	16	11223344556677889900AABBCCDDEEF2					
3	00:00:00:11:22:35	EFLASH	E10000	16	11223344556677889900AABBCCDDEEFF	EFLASH	9000	256	11223344556677889900/	
4	00:00:00:11:22:36	EFLASH	E10000	16	11223344556677889900AABBCCDDEEFF	EFLASH	9000	256	11223344556677889900/	
5	00:00:00:11:22:37	EFLASH	E10000	16	11223344556677889900AABBCCDDEEF5					
6	00:00:00:11:22:38	EFLASH	E10000	16	11223344556677889900AABBCCDDEEF6					
7	00:00:00:11:22:39	EFLASH	E10000	16	11223344556677889900AABBCCDDEEF7					
8	00:00:00:11:22:3A	EFLASH	E10000	16	11223344556677889900AABBCCDDEEF6					
9	00:00:00:11:22:3B	EFLASH	E10000	16	11223344556677889900AABBCCDDEEF7					
10	00:00:00:11:22:3C	EFLASH	E10000	16	11223344556677889900AABBCCDDEEF6					
11	00:00:00:11:22:3D	EFLASH	E10000	16	11223344556677889900AABBCCDDEEF7					
12	00:00:00:11:22:3E	EFLASH	E10000	16	11223344556677889900AABBCCDDEEF6					
13	00:00:00:11:22:3F	EFLASH	E10000	16	11223344556677889900AABBCCDDEEF7					
14	00:00:00:11:22:40	EFLASH	E10000	16	11223344556677889900AABBCCDDEEF7					
15	00:00:00:11:22:41	EFLASH	E10000	16	11223344556677889900AABBCCDDEEF6					
16	00:00:00:11:22:42	EFLASH	E10000	16	11223344556677889900AABBCCDDEEF7					

Figure 23. Custom memory data CSV file example

Each line in the CSV file corresponds to a specific DUT, which is bound to a BD address. The BD address is written in the first column of the CSV file. After the DUT BD address, up to five memory operations can exist.

Each of these operations must have the following columns in the correct order as described below:

- Memory type (DA1459x can have **EFLASH** and **QSPI**)
- Start address
- Size of data in bytes
- Data to be written.

Figure 23 shows an example of a CSV file targeted DA1459X DUTs. In this example the CSV file contains information for DUTs with BD addresses 00:00:00:11:22:33 to 00:00:00:11:22:42. For example for the BD address 00:00:00:11:22:35.

- The first operation is configured to write into the EFLASH address 0xE1000 sixteen bytes (0x11223344556677889900AABBCCDDEEFF).
- The second operation is configured to write into the EFLASH address 0x9000 256 bytes.

SmartBond Production Line Tool

5.11 Golden Unit scan test

This section describes the PLT scan test procedure using the Golden Unit as scanner device.

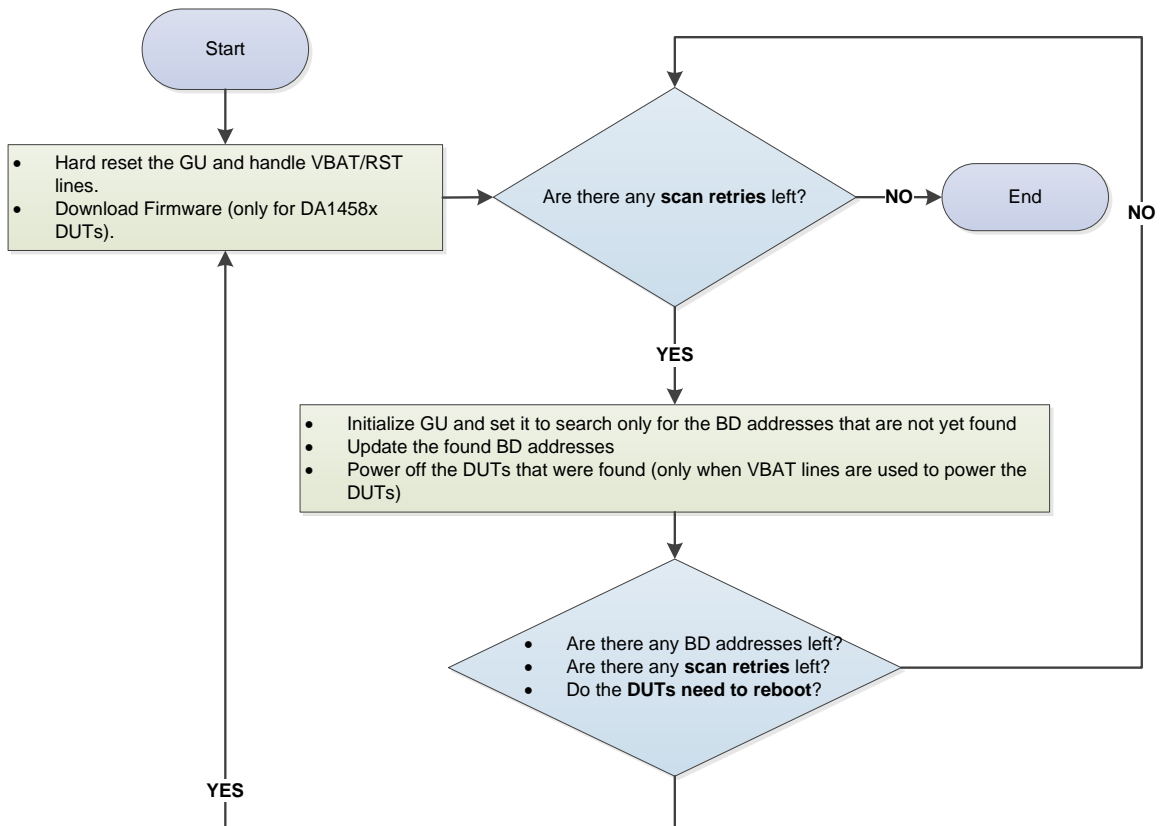

Figure 24. Golden Unit scan test

You can set various scan properties to adjust the Scan test procedure. The available properties are described in Table 49.

Figure 24 shows the scan sequence. First, the GU and the DUTs are reset. The DUTs must be burned with a valid application image that sends Bluetooth Low Energy advertisements after boot. Additionally, the PLT selected BD address should be programmed to the CS of the DUTs, so it is used in advertisements.

The GU begins scanning for the BD addresses of all active DUTs. After each scan cycle, the already found BD addresses are removed from the search list of the GU and the appropriate DUTs are powered off. This procedure continues until the retries have reached the *Scan retries* set by you. The PLT resets the GU after a specific number or retries, given in *DUT reboot* option. Finally, the parameters *DUT reboot time* and *DUT reboot difference* set the DUT time needed to perform a POR with a small delay between the DUTs if needed.

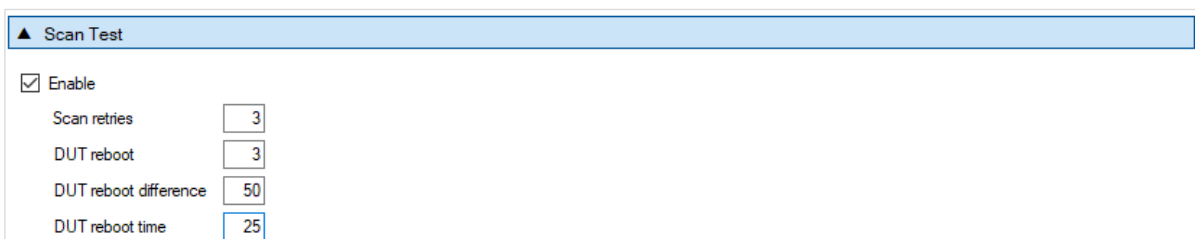

Figure 25. Golden Unit scan test example parameters

SmartBond Production Line Tool

Figure 25 shows an example of DA1459x DUT scan test settings. For this example, the following steps are executed:

1. DUTs should be programmed with a valid application image in the flash memory. The BD address selected by PLT should have been programmed in the CS.
2. Reset the GU to be in a clear state, power-off the DUTs and wait for 2000 ms (DUT reboot time). Power-on DUTs.
3. DUTs should start advertising with the already programmed BD address selected by PLT.
4. Execute three GU scans. When each scan procedure is finished, power-off the found DUTs.
5. Again, power-off the DUTs and wait for 2000 ms (DUT reboot time) until power-on again.
6. Continue with another two GU scans and after each scan procedure power off the found DUTs.

5.12 Creating PLT firmware files

For the PLT to successfully operate, various firmware files are used based on the device type (GU or DUT) and the purpose of the firmware (different firmware for tests and memory programming).

All these firmware files are kept under the `binaries` folder in the PLT software package, as shown in Figure 26. To create these firmware files, the SDK packages should be downloaded from the customer portal and the source code patches located under the `fw_files` folder in the PLT software package shown in Figure 27, should be applied.

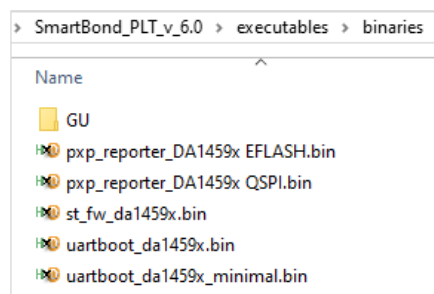

Figure 26. Firmware files

The source code patches maintain the folder structure of the SDK they are targeting to apply the source code patch using a simple copy and replace. After patching, the projects contain all the necessary changes and the same firmware files can be built as those in the `binaries` folder of the PLT software package.

The `fw_files` folder has two main categories. Firmware targeted for the GU and for the DUTs. Under each category there is a folder indicating the IC target and the SDK used.

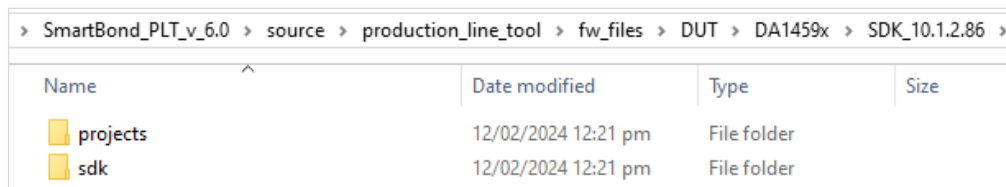

Figure 27. Folder Contents of `fw_files`

Applying a source code patch for each one of the binaries is described below.

5.12.1 Golden Unit firmware

The Golden Unit is a DA14580 device. A modified version of the `prod_test_580.bin` firmware is used.

SmartBond Production Line Tool

This patch contains all the changes needed to re-create the following firmware:

- prod_test_GU.bin

To re-create the exact source code of the prod_test_GU.bin firmware:

1. Use a clean copy of the DA1458x_SDK_5.0.4 SDK from the customer portal.
2. Copy the contents of the ...fw_files\GU\DA1458x_SDK_5.0.4\DA1458x_SDK\5.0.4\ folder to the default SDK.
3. To build the prod_test_GU.bin, under the \5.0.4\projects\target_apps\prod_test\prod_test\Keil_5\ folder, open the Keil v5 project file—prod_test.uvprojx.

5.12.2 DA1459x firmware

This patch contains all the changes needed to re-create the following firmware:

- uartboot_da1459x.bin
- uartboot_da1459x_minimal.bin
- st_fw_da1459x.bin
- pxp_reporter_DA1459x.bin

To re-create the exact source code of the above firmware:

1. On the customer portal, download a new copy of the SDK_10.1.2.86.
2. Copy the contents from fw_files\DUT\DA1459x\SDK_10.1.2.86 folder to the SDK_10.1.2.86 SDK.
3. Start the SmartSnippets™ Studio loading the SDK workspace and import the following projects from the tree structure: st_fw, uartboot, and pxp_reporter.
4. To build the st_fw_da1459x.bin binary, in the workspace, go to the st_fw project, and then click **Release configuration**.
5. To build the uartboot_da1459x.bin binary, in the workspace, go to the uartboot project, and then click **Release RAM configuration**.
6. To build the uartboot_da1459x_minimal.bin binary, in the workspace, go to the uartboot project, and then click **Release minimal configuration**.
7. To build the pxp_reporter_DA1459x.bin binary, in the workspace, go to the pxp_reporter project, and then click **Release eFLASH configuration** or **QSPI configuration** (depending on which flash you are using).

Each binary is created under the project folder in a folder having the same name as the selected option.

SmartBond Production Line Tool

6 Applications

6.1 Introduction

The PLT software includes four different applications (Table 4). The CFG PLT is used to set up the system according to the device hardware options and select the required tests and memory actions to be performed. The GU Upgrade is used to update the Golden Unit firmware. The GUI and the CLI PLT applications are used to perform the tests, monitor their progress in real-time and view the test results.

6.2 CFG PLT application

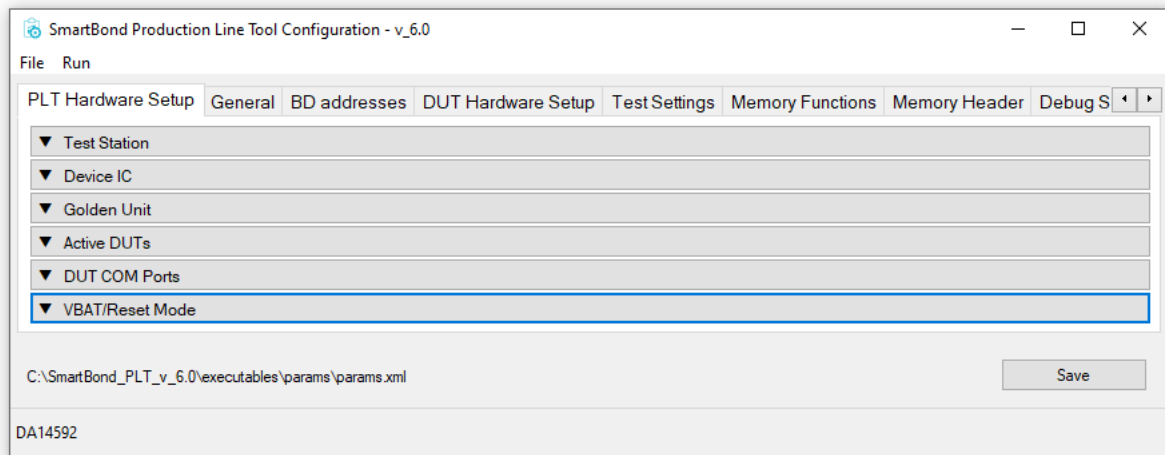

Figure 28. CFG PLT startup window

NOTE

To minimize a field, click it. The field is minimized but it is not disabled.
 The tests run if they are enabled, even when the test field is minimized and not shown.

The CFG PLT application (`SmartBond_PLT_CFG.exe`) is a GUI application tool, which is mainly used to appropriately configure the tests and memory operations the tool performs. Depending on the selected device chipset and the enabled actions, only appropriate options are enabled and shown. Any change you make is validated before being saved to the XML file, with the use of a schema XSD file. This prevents erroneous values to be stored in the XML file that would harm the production procedure.

Figure 28 shows the initial CFG PLT window. The Main Menu options are described in Table 15 and the bottom strip information is described in Table 16. The application begins with the **Hardware Setup** tab (see Section 6.2.2). You can go to the other PLT configurable options by selecting the different tabs.

When a tab is selected, the settings of this tab are reloaded from the XML file. If there is an error in the configuration XML file, a warning message is shown indicating which of the parameters has error. Additionally, the related graphic entry in the CFG application for the erroneous configuration parameter is highlighted in red.

Figure 29 gives an example. Configuration parameter `dut_num_1` has wrong value (`error` instead of either `false` or `true`) in the `params.xml` file. When you select the **Hardware Setup CFG** tab, warning message is displayed. If you click **OK**, the **Hardware Setup** tab is loaded with the **DUT 1** checkbox in red. The displayed value is the default value taken from the XML schema document (`params.xsd`).

SmartBond Production Line Tool

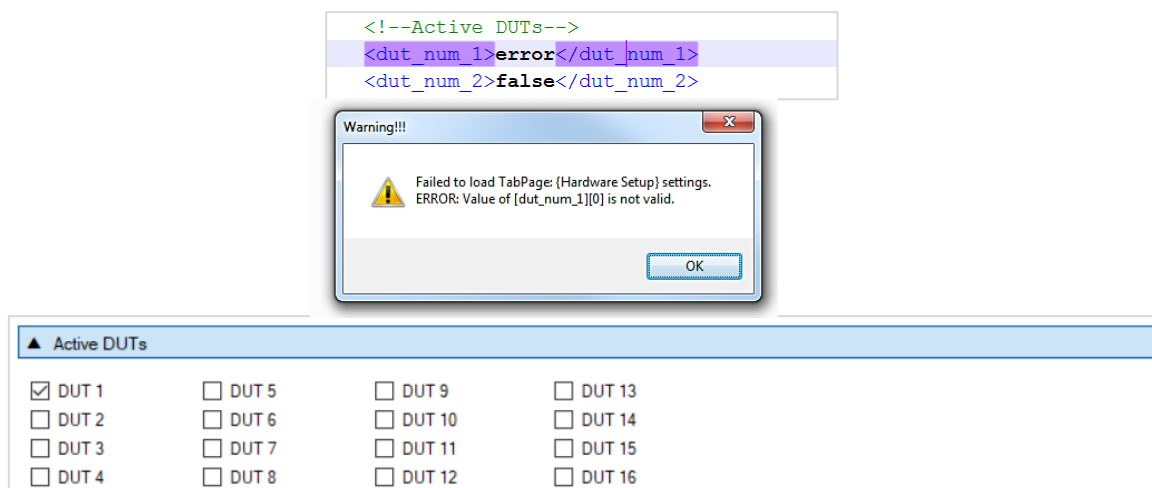

Figure 29. CFG PLT with erroneous configuration parameter

When you make a change, the **Save** button becomes **Save*** to indicate that a save is required. In case of a configuration parameter error, pressing **Save** saves the default parameter value, overwriting the erroneous value.

Table 15. CFG PLT Main menu options

Region	Option	Description
File	Open XML file	Opens a new XML file and loads the settings. The full path of the new XML file is shown at the bottom end of the window.
	View XML file	Opens the XML file in notepad.
	Save as...	Exports all settings to a new XML file. The full path of the new XML file is shown at the bottom end of the window.
	Reset to defaults	Overwrites all parameters options in the XML file with their default values taken from the XSD file.
	Exit	Exits the CFG PLT application.
Run	Run GUI PLT	Opens the GUI PLT application.
	Run CLI PLT	Opens the CLI PLT application.

Table 16. CFG PLT Bottom Strip options

Option	Description
C:\SmartBond_Cobalt_v_5.0\params\params.xml	Shows the full path of the XML file currently used.
DA14701	Shows the selected device IC.
C:\SmartBond_Cobalt_v_6.0\params\params.xml	Shows the full path of the XML file currently used.
DA14592	Shows the selected device IC.
Save	Saves the options of the selected tab. For example, if General settings tab is selected, then only the settings for this tab are saved. A shortcut for this button is Ctrl+S.

SmartBond Production Line Tool

6.2.1 XML and XSD files

The CFG PLT application is a front-end user interface for the `cfg_dll.dll` library (Figure 18). The `cfg_dll.dll` library, explained in detail in Ref. [1], is an XML parser, editor, and parameter validator. It has an easy-to-use API for reading and manipulating the `params.xml` file. File `params.xsd` is the XML schema used for parameter validation.

In the CFG PLT application, all user selectable options are loaded and saved inside the XML file, by effectively using the `cfg_dll.dll` library API. The XSD schema file `params.xsd` is not edited in any way but only read by the `cfg_dll.dll` library API, whenever a parameter validation is needed.

The XSD schema file, `params.xsd`, holds information about the overall structure of the `params.xml` file, the default, and valid values a parameter can take as well as information about the purpose of each parameter that is also displayed as a tooltip in the application GUI. An example part of the XSD file is given in Figure 30.

```
<xs:element name="next_bd_addr"
  type="x:cfg_hex_array_6_bytes"
  x:use="required"
  x:default="00:00:00:00:00:01"
  x:info="The BD address of the first active DUT that will be used in the next test run. "/>
<!--cfg_hex_array_6_bytes-->
<xs:simpleType name="cfg_hex_array_6_bytes">
  <xs:restriction base="xs:string">
    <xs:pattern value="([0-9A-Fa-f]|[0-9A-Fa-f][0-9A-Fa-f])(:([0-9A-Fa-f]|[0-9A-Fa-f][0-9A-Fa-f])){5}"/>
  </xs:restriction>
</xs:simpleType>

<xs:element name="RF_path_loss_DUT_1"
  type="x:cfg_dut_path_losses"
  x:use="required"
  x:default="0"
  x:info="Set the RF path losses in dB between the device and the GU or the BLE tester instrument."/>
<!--cfg_dut_path_losses-->
<xs:simpleType name="cfg_dut_path_losses">
  <xs:restriction base="xs:float">
    <xs:minInclusive value="0"/>
    <xs:maxInclusive value="40"/>
  </xs:restriction>
</xs:simpleType>
```

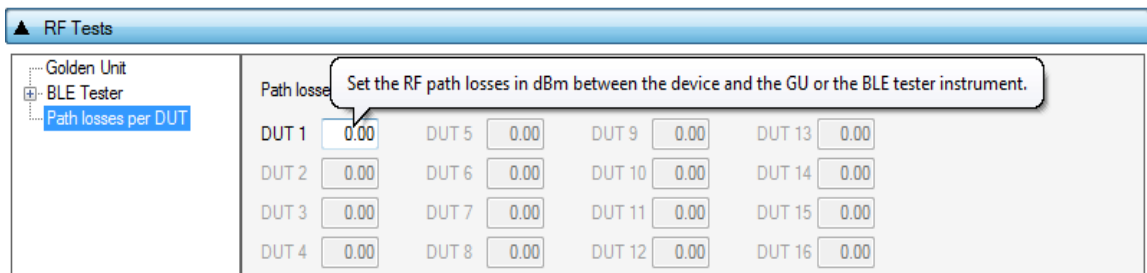

Figure 30. XSD Schema file example

Element `next_bd_addr` holds the Next BD address, as described in Section 6.2.4.1 and Table 26. It has a default value of `x:default="00:00:00:00:00:01"`. This default value is returned by the `cfg_dll.dll` API if the XML file has an error entry in the equivalent `next_bd_addr` element, since the validation of the parameter fails.

The `x:info="The BD address ..."` value is loaded by the `cfg_dll.dll` API and is used in the CFG PLT tooltips. The `type="x:cfg_hex_array_6_bytes"` defines the parameter type. This is the actual XSD entry that is used for the parameter validation. The `cfg_hex_array_6_bytes` type is defined later in the file and has a rather complicated pattern defined with `<xs:pattern value = "([0-9A-Fa-`

SmartBond Production Line Tool

f]..."/>. If the `next_bd_addr` element in the XML file has a value that does not match this pattern, the validation of the parameter fails and the `cfg_dll.dll` API returns the default value (00:00:00:00:01). In the CFG PLT, the default value is shown in red, indicating that an error exists in the `params.xml` file for this parameter. It does not change the erroneous value in the `params.xml` file until the you click the **Save** button, in which case the default value overwrites the erroneous value.

In the second example of [Figure 30](#), the `RF_path_loss_DUT_1` XSD element is shown. This element is used in the Path Losses per DUT as shown in [Figure 55](#). This element has a default value of 0 and the allowed values are floats, between `<xs:minInclusive value="0"/>` and `<xs:maxInclusive value="40"/>`, as shown in the `cfg_dut_path_losses` type description. The `x:info="Set the RF path .."/>` is loaded by the `cfg_dll.dll` API and used in the CFG PLT tooltips as shown in the bottom part of [Figure 30](#).

6.2.2 Hardware setup

This section describes the Hardware Setup settings available for the PLT hardware board, shown in [Figure 28](#).

6.2.2.1 Test Station

Figure 31. Station identification

These fields hold the **Station ID** and **Tester ID** names to distinguish between different test stations and users. The values of these fields are written into the DUT logs and CSV files. [Table 17](#) describes the available options for the station identification.

Table 17. Station identification

Option	Description
Station ID	The name of the PLT test station.
Tester ID	The PLT tester ID name.
Ask for Tester ID on start-up	When <code>SmartBond_PLT_GUI.exe</code> starts, it asks for the tester ID name.

6.2.2.2 Device IC

Figure 32. Device IC

You can select the device IC type. This option may change any IC related configuration parameters and their equivalent graphics, such as selectable tabs and tests. [Table 18](#) describes the available options for the device IC.

Table 18. Device IC

Option	Description
Device IC	The Renesas Bluetooth® LE chipset used in the device under test.

SmartBond Production Line Tool

6.2.2.3 Active DUTs

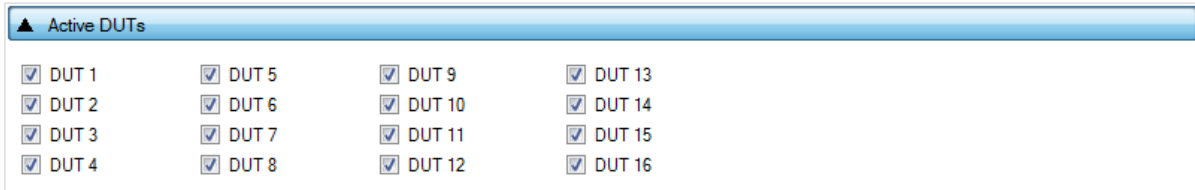

Figure 33. Active DUTs

Enables or disables the testing for each DUT. Table 19 describes the available options for the Active DUTs.

Table 19. Active DUTs

Option	Description
DUT1-16	Enables the specific DUT device placed on connector DUT1-DUT16.

6.2.2.4 DUT COM ports

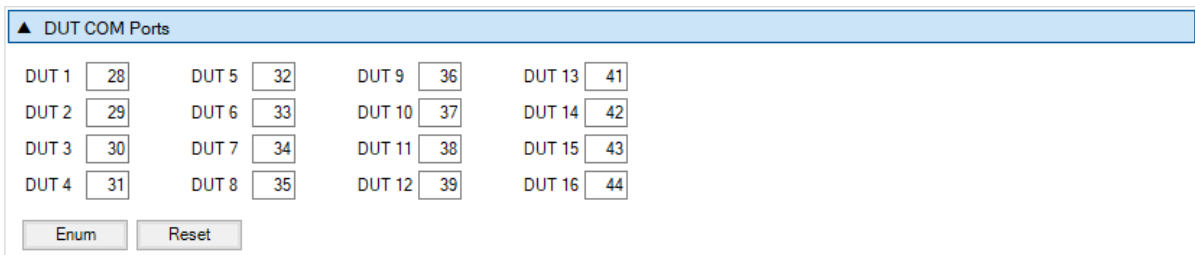

Figure 34. DUT COM ports

This field shows the Windows COM port assigned to each DUT. The table is filled only when the COM Enum action is performed by the CFG or the GUI PLT applications, or when non-zero entries exist in the com_port_x params.xml options. When the COM Enum action is performed, the tools automatically find the DUT COM ports and save them in the params.xml file. These values are read by the CFG PLT application and be displayed here. When a COM Enum action are not performed, the GUI PLT automatically runs it once in every first test execution.

NOTE
Great care must be taken when the params.xml file is shared across different test stations, where different DUT COM Ports probably exist. The COM Enum action should then be performed again, so the new COM ports of the new PC system are identified and updated in the XML file.

Table 20 describes the available options for the DUT COM Ports.

Table 20. DUT COM Ports

Option	Description
DUT1-16	Shows the Widows COM port assigned to a specific DUT.
Reset	Sets all values to zero.
Enum	Executes the COM port enumeration procedure. The found COM ports are shown before being saved.

SmartBond Production Line Tool

6.2.2.5 Golden Unit

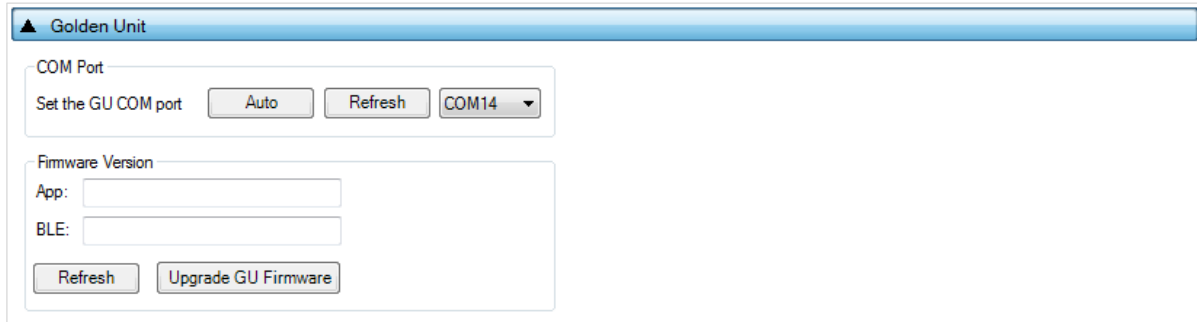

Figure 35. Golden Unit COM port

This field holds the Golden Unit COM port. Manual or automatic COM port find can be selected.

The Golden Unit COM port can be manually selected from the list with all the available COM ports existing in the system. Additionally, it can automatically be found by clicking the **Auto** button. The automatic procedure searches the serial number of all system COM ports to find the `DialogSemi` string. Details on how to program the serial number in the GU FTDI can be found in [Appendix H](#).

Table 21. Set the GU COM port

Option	Description
Auto	Initiates the automatic Golden Unit COM port find procedure.
Refresh	Refreshes the dropdown menu with all the available system COM ports.
Dropdown Menu	Manually select the Golden Unit COM port from all the available system COM ports.

Table 22. Golden Unit Firmware Version Upgrade

Option	Description
Refresh	Retrieves the current Bluetooth® LE and application versions of the connected Golden Unit.
Upgrade GU Firmware	Opens the Section 6.5 application, which is used to update the GU firmware.

6.2.2.6 VBAT/Reset mode

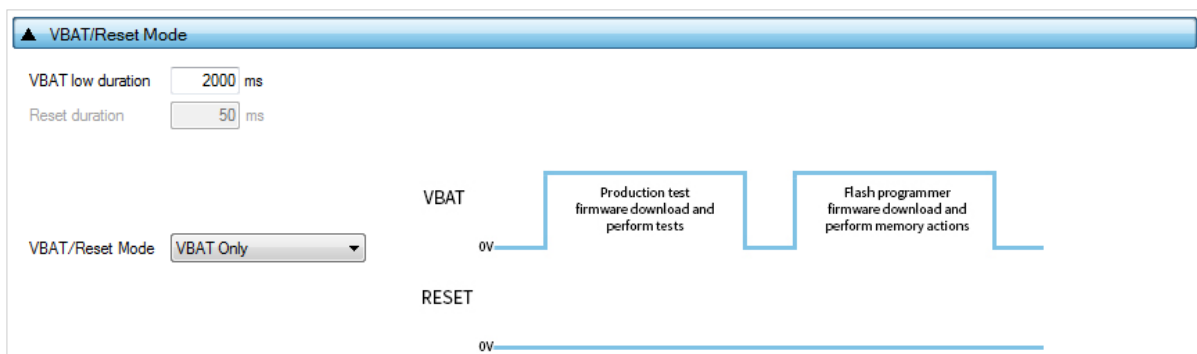

Figure 36. VBAT/Reset mode selection

This field holds the VBAT/Reset mode selections. This option sets the PLT VBAT and PLT Reset line modes for the DUT power supply and reset during the PLT test sequence. [Table 23](#) describes the available selections.

SmartBond Production Line Tool

Table 23. VBAT/Reset mode

Option	Description
VBAT/Reset Mode	Select the operation for VBAT/Reset signals. Available options are: <ul style="list-style-type: none"> • VBAT Only • VBAT On with Reset Section 5.9 describes each mode in detail. Default setting is VBAT only .

6.2.3 General

6.2.3.1 Statistics

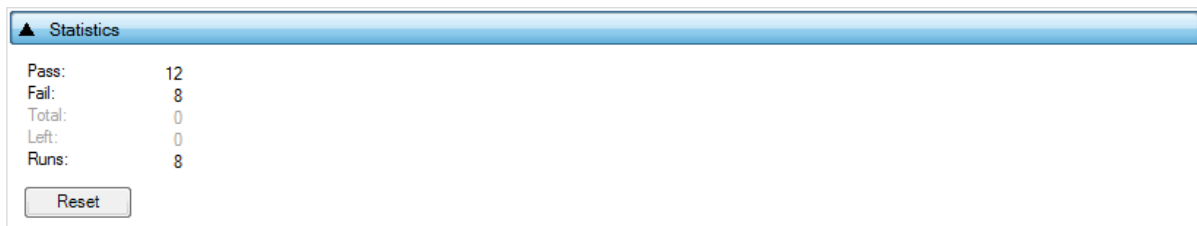

Figure 37. Statistics

This field holds the test result statistics. Table 24 describes the **Statistics** pane.

Table 24. Statistics

Option	Description
Pass	Shows the number of DUTs that have successfully passed all the tests.
Fail	Shows the number of DUTs that have failed the tests.
Total	Shows the number of DUTs that are tested. This option is available only when <i>Range</i> mode is enabled in Section 6.2.4.1.
Left	Shows how many DUTs are still to be tested. This option is available only when <i>Range</i> mode is enabled in Section 6.2.4.1.
Runs	Shows the number of test-runs the PLT has performed.
Reset	Pressing the Reset button clears all statistics values to their defaults. Values <i>Pass</i> , <i>Fail</i> and <i>Runs</i> are set to zero. If <i>Range</i> mode is enabled in Section 6.2.4.1, the <i>Total</i> and <i>Left</i> values are set as the difference of <i>Next</i> and <i>End BD address</i> , otherwise are set to zero.

SmartBond Production Line Tool

6.2.3.2 Test options

Figure 38. Test options

This field holds generic PLT test procedure options. The PLT procedure is split into two main parts: *Production tests* and *Memory programming*.

Production tests include all the tests under in Section 6.2.5.2.

Figure 39. Reset polarity

Reset Polarity selected here is used in combination with the reset method. If the reset method is set to *VBAT only* then this setting is ignored. Depending on the implementation, active high or active low reset signal might be required. This setting controls the reset polarity as active high or active low.

Test Settings. Memory Programming includes all the tests in Sections 6.2.7 and 6.2.8.

Table 25. Test options

Option	Description
Production tests	This option enables the production test operations.
Memory programming	This option enables the memory programming operations.
Notify user for CS burning	When this option is enabled, PLT informs you of all the CS burning tests that are enabled. A pop-up message appears, prompting you whether to proceed with the tests.
Firmware download retries	Configures the firmware download retries in case of an error during firmware download.
Re-test failed DUTs	When this option is enabled, any DUT that failed is immediately retested with the exact same options, including the <i>BD address</i> . This option is the same to the <i>Retest failed DUTs - Enable</i> in Section 6.3.1.

SmartBond Production Line Tool

Option	Description
Enable VBAT and UART at the end of the tests	Enables the VBAT lines and UART communication between the PC and the devices after all the tests are finished. If enabled, DUTs remain powered after the end of the tests.
Reset VBAT	If this option is enabled the VBAT line is toggled. If not selected, the DUTs are not rebooted, thus their system RAM has the last test firmware downloaded by the PLT (either the <code>st_fw_da1459x.bin</code> or the <code>uartboot_da1459x.bin</code>).
Run script before testing starts	This option enables the execution of a batch or an executable before the device testing procedure starts. As described in Section 6.3.2, the success return code should be a value between 0 and 100 for the tool not to report an error. Any other value is taken as error and prevent the tool from running the tests.
Enable script timeout	Enables a wait timeout for the script to finish. The time to wait is set in the Timeout field. If this option is disabled PLT waits until the script ends.
Timeout	The time to wait for the script to finish.
Script path	The path of file to execute when the <i>Run script before testing starts</i> option is enabled.
Run script when testing is finished	This option enables the execution of a batch or an executable after the device testing procedure is finished. The success return code should be 0 for the tool not to report an error.
Enable script timeout	Enables a wait timeout for the script to finish. The time to wait is set in the Timeout field. If this option is disabled, PLT waits until the script ends.
Timeout	The time to wait for the script to finish.
Script path	The path of file to execute when the <i>Run script when testing is finished</i> option is enabled.

SmartBond Production Line Tool

6.2.4 BD addresses

6.2.4.1 BD Address Assignment

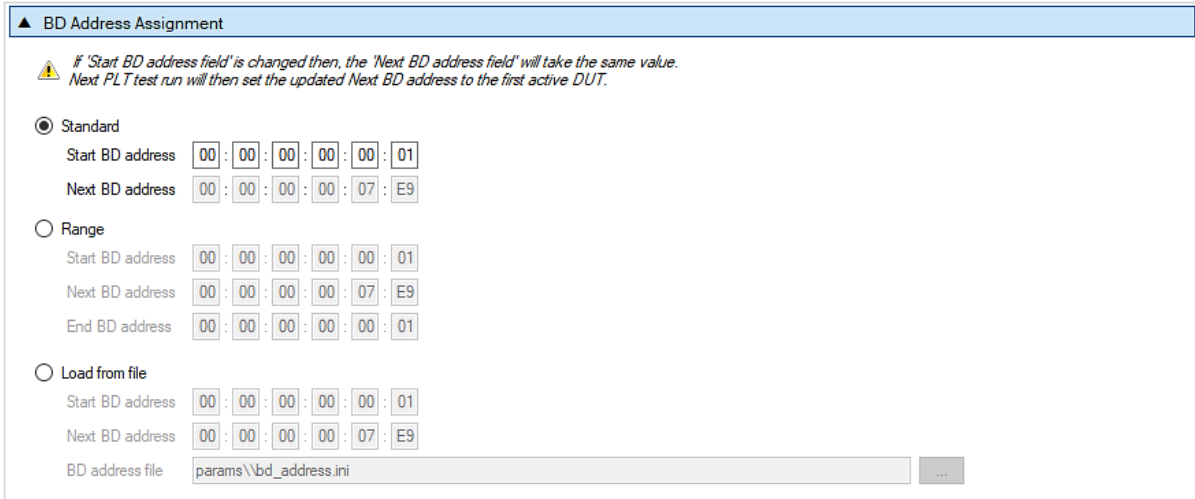

Figure 40. BD Address Assignment

The **BD Address Assignment** field defines different ways the PLT can handle the device BD address. The available modes are **Standard**, **Range** or **Load from file**.

The **Standard**, **Range**, and **Load from file** modes are similar. These have **Start BD address**, which is the initial address that the PLT session begins. The **Next BD address** field holds the BD address that is used on the next PLT run, so the BD address assignment can be continued even after the GUI PLT is closed. For that reason, you cannot alter **Next BD address**. When the PLT session begins, the **Next BD address** initial value is the same as the **Start BD address**.

NOTE
In CFG PLT, only Start BD address is given. The assignment of the actual device BD addresses occurs in the GUI PLT at the beginning of each test run.
The only invalid BD address is 00:00:00:00:00:00.

Standard mode

Table 26 describes the available options for the *Standard* mode. In this mode, the first active DUT takes the **Next BD address** value. This BD address is incremented by one and assigned to the next active DUT until all active DUTs have a BD address assigned to them.

This assignment mode never runs out of BD addresses and it continues assigning addresses until **Next BD address** reaches FF:FF:FF:FF:FF:FF.

Table 26. BD Address Assignment - Standard mode

Option	Description
Start BD address	The BD address that the PLT session started with.
Next BD address	The BD address that is used in the first active DUT of the next PLT run.

Range mode

Table 27 describes the available options for the *Range* mode. This mode is the same as *Standard* mode except for the additional *End BD address*.

SmartBond Production Line Tool

Because a Start BD address and an End BD address exist, the total amount of devices to be tested can be calculated. Therefore, this mode enables the **Total** and **Left** fields in Section 6.2.3.1, where **Total** is the number of the BD addresses to be used from **Start BD address** to **End BD address** and **Left** is the number of BD addresses remaining.

NOTE
The End BD address must always be greater than Start BD address . In addition, when Left BD addresses are not enough for the remaining active DUTs, the PLT does not run.

Table 27. BD Address Assignment options - Range mode

Option	Description
Start BD address	The BD address that the PLT session started with.
Next BD address	The BD address that is used in the first active DUT of the next PLT run.
End BD address	The BD address that the PLT session ends with.

Load from File mode

Table 28 describes the available options for the *Load from file* mode. In this mode, the **Start BD address** and the **Next BD address** have the same roles as before. The difference in this mode is that the BD addresses are loaded from a file in the order as they are written in that file, not using the automatic incremental method of the previous modes. In every test run, the PLT searches for the first occurrence of **Next BD address** in the file and loads it along with the BD addresses that follow, until all active DUTs have a BD address.

1	00:00:00:44:33:0a
2	00:00:00:44:33:09
3	00:00:00:44:33:08
4	00:00:00:11:22:08
5	00:00:00:11:22:06
6	00:00:00:11:22:05
7	00:00:00:11:22:04
8	00:00:00:11:22:03
9	00:00:00:11:22:02

Figure 41. Example for Load from File mode

For example, consider three active DUTs: DUT3, DUT6, and DUT 9 and the **Next BD address** to be 00:00:00:11:22:08. Figure 41 shows the beginning of the BD address file used in this example. The PLT searches for the **Next BD address** in the file and loads it to the first active DUT, DUT3. It then continues with 00:00:00:11:22:06 for DUT6 and 00:00:00:11:22:05 for DUT9. It also returns 00:00:00:11:22:04 as the **Next BD address** to be used at the next PLT test run.

NOTE
The BD address file should always end with a zero BD address (00:00:00:00:00:00) and a new line at the end.

Table 28. BD Address Assignment options - Load from File mode

Option	Description
Start BD address	The BD address that the PLT session started with.
Next BD address	The BD address from file that is used in the first active DUT of the next PLT run.

SmartBond Production Line Tool

Option	Description
BD address file	Path to the file that contains the BD addresses. Use button [...] on the right to navigate and select a file.

6.2.5 DUT hardware setup

6.2.5.1 UART Baud Rate



Figure 42. UART Baud Rate

Table 29 shows the available options for the UART Baud Rate used during memory programming.

The Baud Rate selected here is used after the firmware (`uartboot_da1459x.bin`) is downloaded to the DUT. The software sends a command to the DUT to change the UART baud rate to the one selected. All following UART communications with the DUT are performed using the new baud rate. Note that this is happening only during memory programming where `uartboot_da1459x.bin` is used. During tests (RF tests, XTAL trimming, and so on), where the production test firmware is used, the baud rate is fixed to 115200 bit/s.

Table 29. UART Baud Rate

Option	Description
Baud Rate	<ul style="list-style-type: none"> ● 9600 (bit/s) ● 57600 (bit/s) ● 115200 (bit/s) ● 1000000 (bit/s) ● 2000000 (bit/s) <p>Note: 1 Mbit/s and 2 Mbit/s are the fastest and safest with 0% baud rate error.</p>

6.2.5.2 Reset Polarity

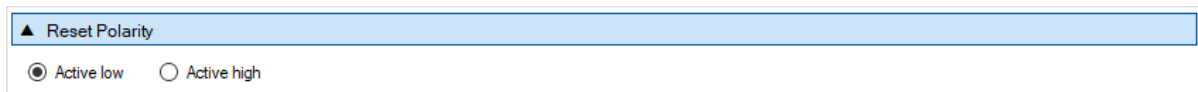

Figure 43. Reset Polarity

The Reset Polarity selected here is used in combination to the reset method. If the reset method is set to VBAT only then this setting is ignored. Depending on the implementation, active high or active low reset signal might be required. This setting controls the reset polarity as active high or active low.

SmartBond Production Line Tool

6.2.6 Test settings

6.2.6.1 VBAT Level Log

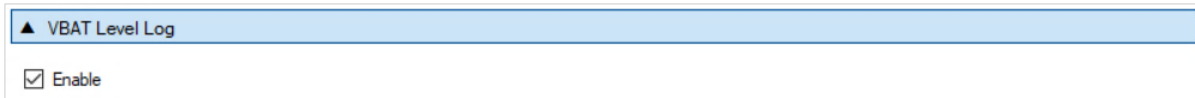

Figure 44. VBAT Level Log

When this feature is enabled, PLT sends a command to the device to measure VBAT using its internal ADC. The VBAT level then is logged. No, pass, or fail limits exist for this test. It is only used for logging purposes.

6.2.6.2 Factory Timestamp Read

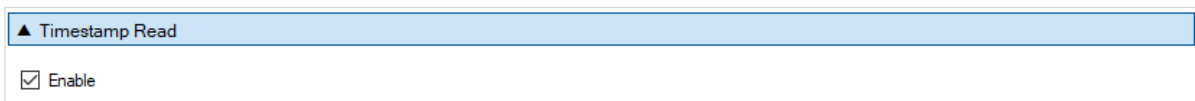

Figure 45. Factory Timestamp Read

If this option is enabled, PLT reads the device timestamp from the factory CS area and log it. This operation is mainly used for logging purposes.

6.2.6.3 XTAL Trim

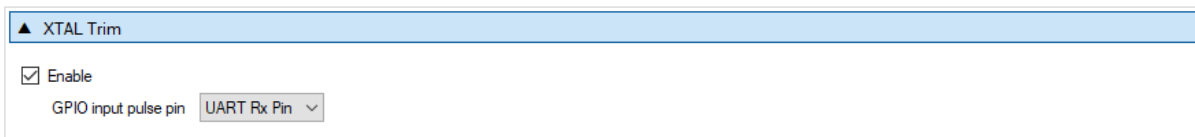

Figure 46. XTAL Trim

Table 30 describes the available options for the XTAL Trim operation.

Table 30. XTAL Trim

Option	Description
Enable	This option enables the automatic crystal oscillator frequency calibration procedure.
GPIO input pulse pin	The DUT GPIO to receive the reference pulse during calibration. UART RX pin can be used without any additional connection from the PLT hardware to the DUT.

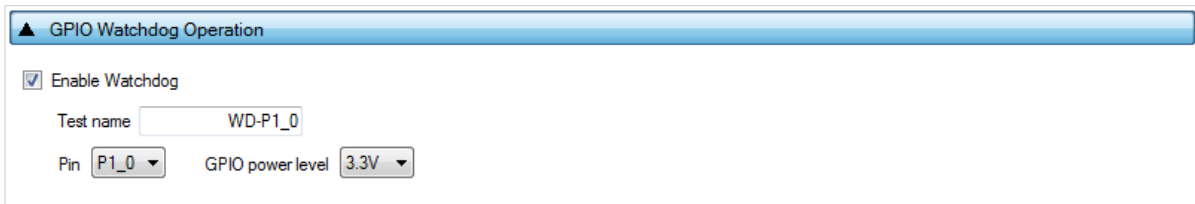

Figure 47. GPIO Watchdog Operation

Table 31 describes the available options for the GPIO Watchdog operation.

SmartBond Production Line Tool

Table 31. GPIO Watchdog Operation

Option	Description
Enable Watchdog	This option enables the continuous toggling of a GPIO during the whole production testing and memory programming procedure, except during firmware download. The pulse on the GPIO has approximately 0.75% duty cycle and 0.5 Hz frequency. Note: Production test firmware is downloaded through <code>uartboot_da1459x.bin</code> . After the <code>uartboot</code> firmware is downloaded, the watchdog pin is pulsed.
Test name	The name assigned for this test.
Pin	Select the GPIO that is toggled.
GPIO power level	Sets the power level of the GPIOs.

6.2.6.4 Scan DUT Advertise Test

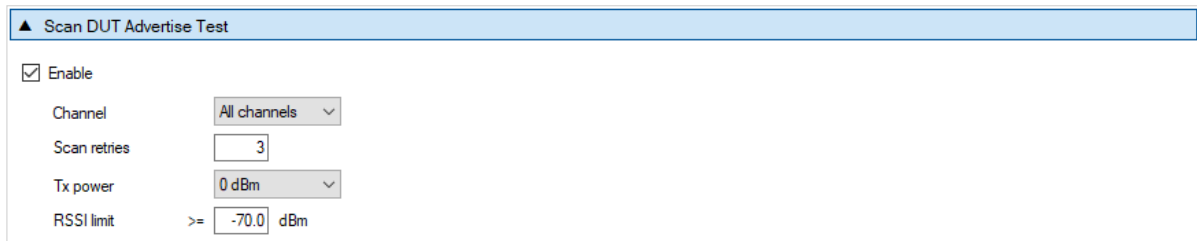

Figure 48. Scan DUT Advertise Test



Table 32 describes the available options for the Scan DUT Advertise Test operation.

Table 32. Scan DUT Advertise Test

Option	Description
Enable	This option enables the Scan DUT Advertise Test operation.
Channel	The Bluetooth® LE channel frequency used in the RF RX test using the Golden Unit.
Scan retries	The number of retries to perform the test.
TX Power	The Bluetooth® LE TX Power to be used by the device for the test.
RSSI limit	The RSSI limit for pass/fail criteria in the RF RX test using the Golden Unit. If the average RSSI of the device, after it is received the packets transmitted from the Golden Unit is less than that the test is considered as failed.

6.2.6.5 RF Tests

This section refers to various RF tests conducted between the DUTs and the Golden Unit or an external Bluetooth® LE tester.

The following tests can have multiple instances with different settings. Tests can be added and removed using the two buttons (for example,  and  in Figure 49) at the lower right side of each panel.

NOTE
When adding or removing a test all settings are refreshed with the values written to the XML file, meaning that any unsaved settings are lost.

SmartBond Production Line Tool

Golden Unit

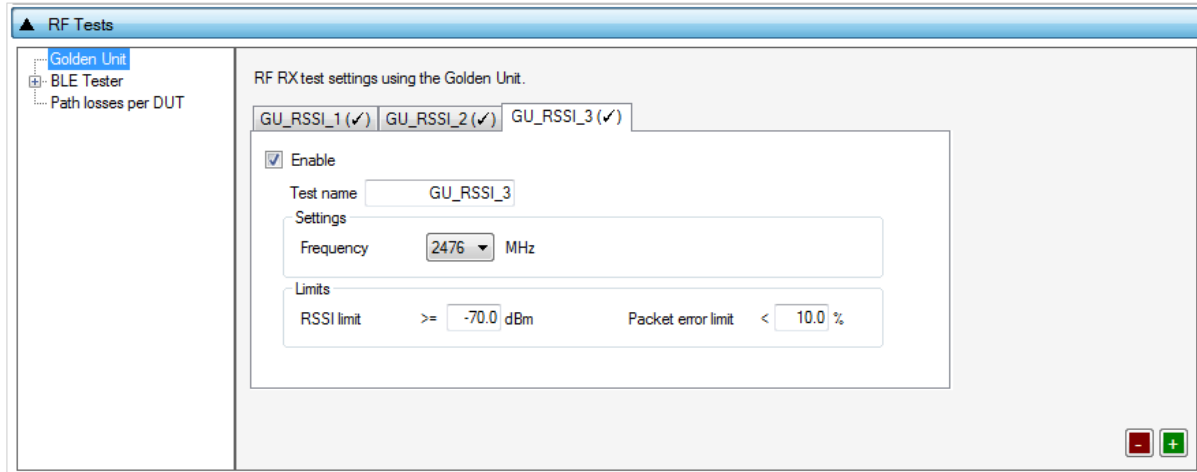

Figure 49. Golden Unit RF Tests

Table 33 describes the available options for the RF RX test using the Golden Unit as a transmitter.

In the RF RX test, the Golden Unit sends 500 packets. The DUTs are set in Receive mode and the RSSI is measured. If the RSSI measured by the DUT reception is less than the specified RSSI limit, the device fails, and the tests stop for that particular device.

Table 33. Golden Unit RF Tests

Option	Description
Enable	This option enables the specific RF RX test using the Golden Unit as a transmitter.
Test name	The name assigned to each test. The assigned name is shown on the tab and next to it an indication showing whether the specific test is enabled or not.
Frequency	The Bluetooth® LE channel frequency used in the RF RX test using the Golden Unit.
RSSI limit	The RSSI limit for pass/fail criteria in the RF RX test using the Golden Unit. If the average RSSI of the device after it has received the packets transmitted from the Golden Unit is less than this value, the test is considered as failed.
Packet error limit	This configures the PER limit for pass/fail criteria. If the percentage of the correct packets received is less than the value entered here, the test fails.

Bluetooth® LE Tester

In the *BLE Tester* panels, several tests can be enabled that require an external Bluetooth® LE tester instrument. For more detailed information about the Bluetooth® LE tester, see Ref. [1].

BLE Tester - General

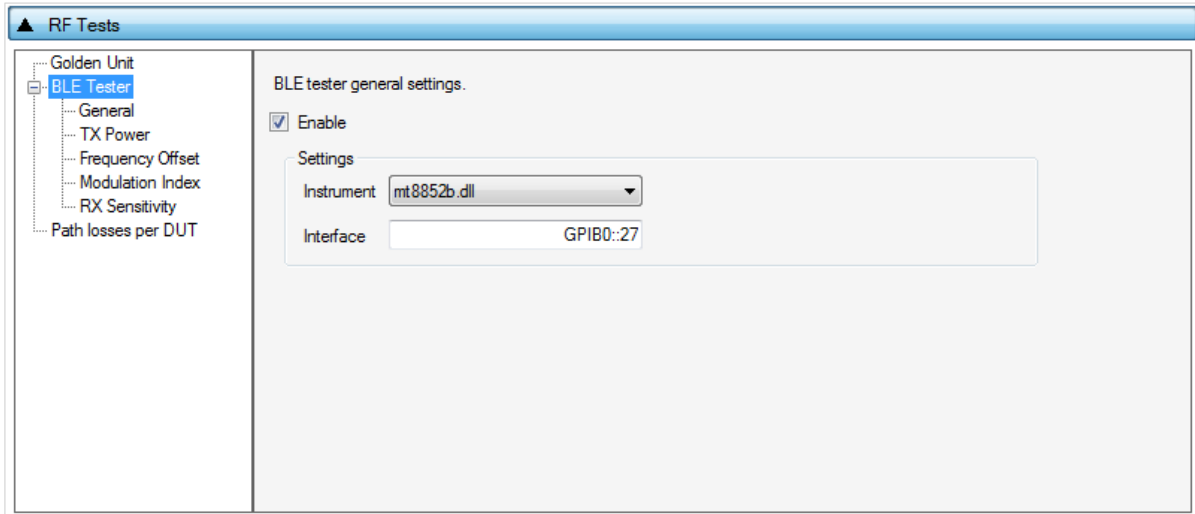

Figure 50. BLE Tester General Settings

Table 34 describes the General settings for the BLE Tester supported tests. Any available external instrument found by the `ble_tester_driver` DLL and their interfaces can be selected.

Table 34. BLE Tester General Settings

Option	Description
Enable	This option enables the BLE Tester tests, which include: <ul style="list-style-type: none"> • Bluetooth® LE Tester TX Power • Frequency Offset • Modulation Index • RX Sensitivity
Instrument	Selects the Bluetooth® LE tester DLL. Names are shown only if a Bluetooth® LE tester instrument DLL exists in the project folder <code>ble_tester_instr_plugins</code> .
Interface	The interface of the instrument to be used by the driver.

SmartBond Production Line Tool

BLE Tester - TX Power

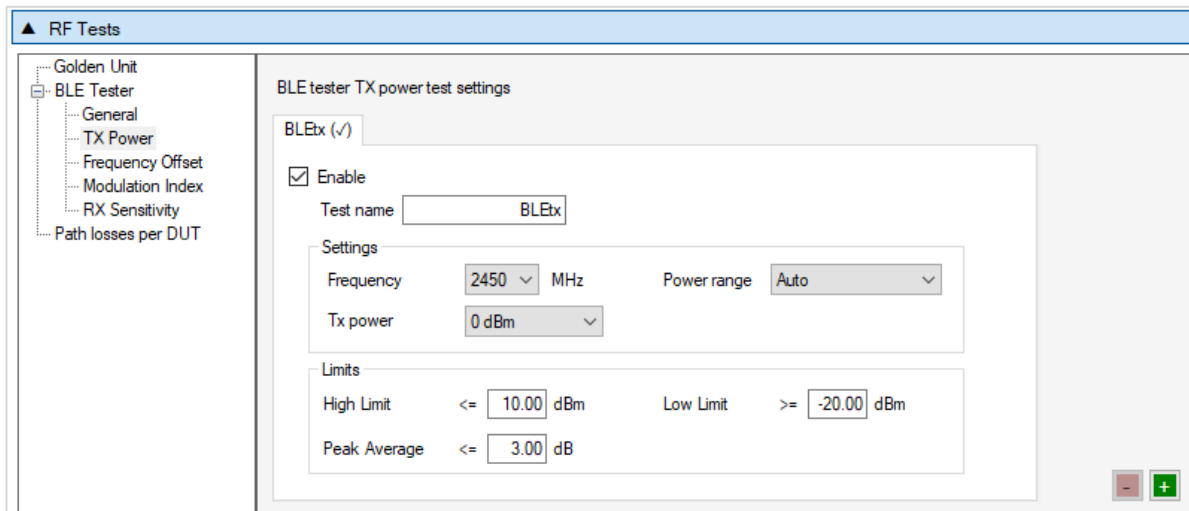

Figure 51. BLE Tester TX Power

Table 35 describes the available options for the TX Power test using a Bluetooth® LE Tester instrument.

Table 35. BLE Tester TX Power

Option	Description
Enable	This option enables the specific TX power test using a Bluetooth® LE tester instrument.
Test name	The name assigned to each test. The assigned name is shown on the tab and next to it an indication showing whether the specific test is enabled or not.
Frequency	The Bluetooth® LE channel frequency used in the Bluetooth® LE TX power test.
Power range	Set the device TX output power range. Available options are: <ul style="list-style-type: none"> • Auto (No auto option for Litepoint IQxel-M. Sets the instrument to trigger at -25 dBm) • +22 dBm to +7 dBm • +9 dBm to -3 dBm • +5 dBm to -7 dBm • -4 dBm to -16 dBm • -12 dBm to -26 dBm • -24 dBm to -35 dBm Default value is <i>Auto</i> .
Tx Power	The DUT transmits output power. -50 dBm to +6 dBm is supported.
High limit	Set the average high-power limit for the Bluetooth® LE TX output power pass/fail test criteria.
Low limit	Set the average low-power limit for the Bluetooth® LE TX output power pass/fail test criteria.
Peak average	Set the peak-to-average power limit for the Bluetooth® LE TX output power pass/fail test criteria.

SmartBond Production Line Tool

BLE Tester - Frequency Offset

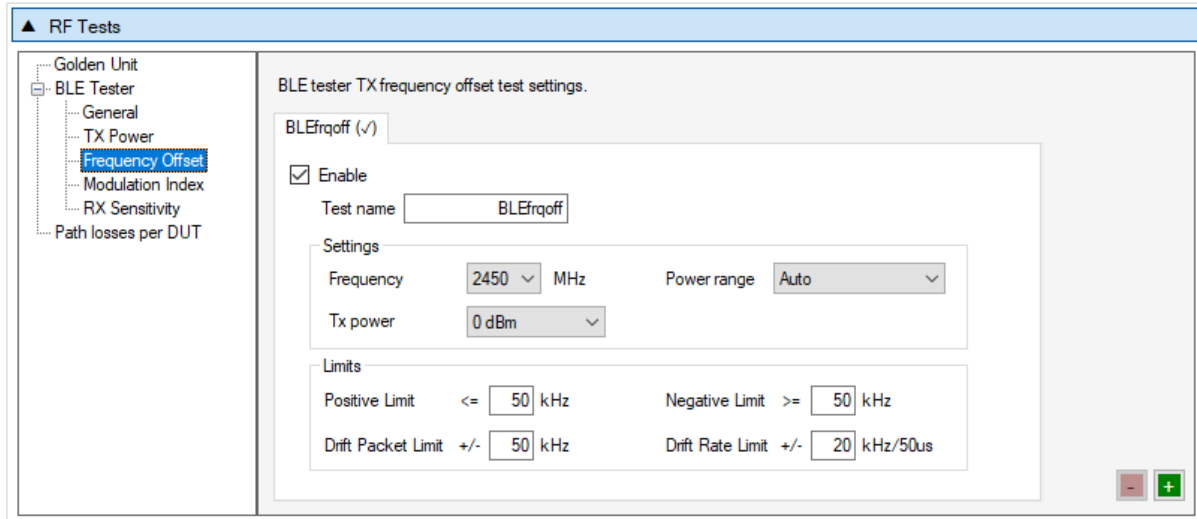

Figure 52. BLE Tester Frequency Offset

Table 36 describes the available options for the Frequency Offset test using a Bluetooth® LE Tester instrument.

Table 36. BLE Tester Frequency Offset

Option	Description
Enable	This option enables the specific TX frequency offset test using a Bluetooth® LE tester instrument.
Test name	The name assigned to each test. The assigned name is shown on the tab and next to it an indication showing whether the specific test is enabled or not.
Frequency	The Bluetooth® LE channel frequency used in the Bluetooth® LE TX frequency offset test.
Power range	Set the device TX output power range. Available options are: <ul style="list-style-type: none"> • Auto • +22 dBm to +7 dBm • +9 dBm to -3 dBm • +5 dBm to -7 dBm • -4 dBm to -16 dBm • -12 dBm to -26 dBm • -24 dBm to -35 dBm Default value is <i>Auto</i> .
Tx Power	The DUT transmits output power. -50 dBm to +6 dBm is supported.
Positive limit	Set the maximum positive offset limit in kHz for the TX carrier frequency offset pass/fail test criteria.
Negative limit	Set the maximum negative offset limit in kHz for the TX carrier frequency offset pass/fail test criteria.
Drift packet limit	Set the overall packet drift in kHz for the TX drift pass/fail test criteria.
Drift rate limit	Set the drift rate limit in kHz/50 μs for the TX drift pass/fail test criteria.

SmartBond Production Line Tool

BLE Tester - Modulation Index

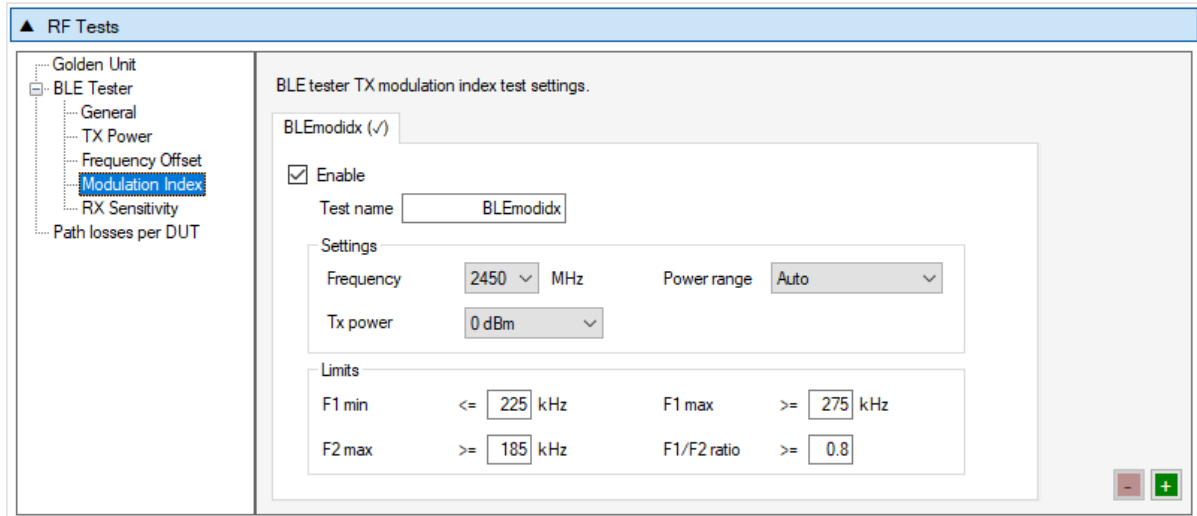

Figure 53. BLE Tester Modulation Index

Table 37 describes the available options for the Modulation Index test using a Bluetooth® LE Tester instrument.

Table 37. BLE Tester Modulation Index

Option	Description
Enable	This option enables the specific TX modulation index test using a Bluetooth® LE tester instrument.
Test name	The name assigned to each test. The assigned name is shown on the tab and next to it an indication showing whether the specific test is enabled or not.
Frequency	The Bluetooth® LE channel frequency used in the Bluetooth® LE TX modulation index offset test.
Power range	Set the device TX output power range. Available options are: <ul style="list-style-type: none"> • Auto • +22 dBm to +7 dBm • +9 dBm to -3 dBm • +5 dBm to -7 dBm • -4 dBm to -16 dBm • -12 dBm to -26 dBm • -24 dBm to -35 dBm Default value is <i>Auto</i> .
Tx Power	The DUT transmits output power. -50 dBm to +6 dBm is supported.
F1 min	Set the F1 minimum average limit in kHz for the TX modulation index pass/fail test criteria.
F1 max	Set the F1 maximum average limit in kHz for the TX modulation index pass/fail test criteria.
F2 max	Set the F2 maximum limit in kHz for the TX modulation index pass/fail test criteria.
F1/F2 ratio	Set the F1/F2 maximum average ratio limit for the TX modulation index pass/fail test criteria.

BLE Tester - RX Sensitivity

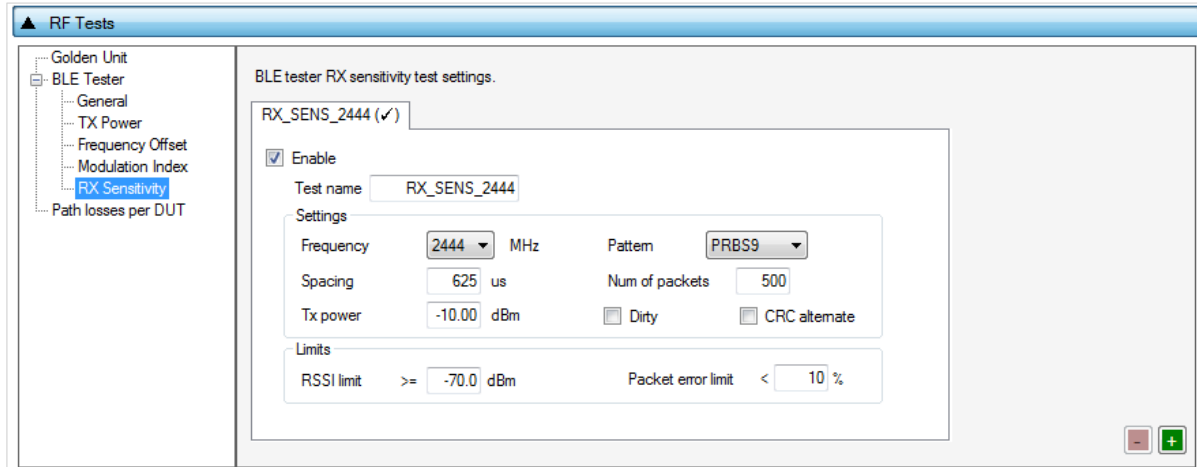

Figure 54. BLE Tester RX Sensitivity

Table 38 describes the available options for the RX Sensitivity test using a Bluetooth® LE Tester instrument.

Table 38. BLE Tester RX Sensitivity

Option	Description
Enable	This option enables the specific RX sensitivity test using a Bluetooth® LE tester instrument.
Test name	The name assigned to each test. The assigned name is shown on the tab and next to it an indication showing whether the specific test is enabled or not.
Frequency	The Bluetooth® LE channel frequency used in the Bluetooth® LE RX sensitivity test.
Pattern	The bit pattern of the TX data. Available options are: <ul style="list-style-type: none"> • PRBS9 • 10101010 • 11110000
Spacing	The packet spacing in μ s.
Num of packets	The number of packets the Bluetooth® LE tester instrument to transmit.
Tx power	The TX output power of the Bluetooth® LE tester instrument. Suggested values are 0 to -10 dBm.
Dirty	When enabled, the Bluetooth® LE tester packet generator can use a dirty table to transmit.
CRC alternate	When enabled, the Bluetooth® LE tester alternatingly sends packets with CRC correct and CRC incorrect.
RSSI limit	The RSSI limit for pass/fail criteria in the RF RX sensitivity test. If the average RSSI of the device after it received the transmitted packets is less than this value, the test is considered as failed.
Packet error limit	This configures the PER limit for pass/fail criteria. If the percentage of the correct packets received is less than the value entered here, the test fails.

SmartBond Production Line Tool

Path Losses per DUT

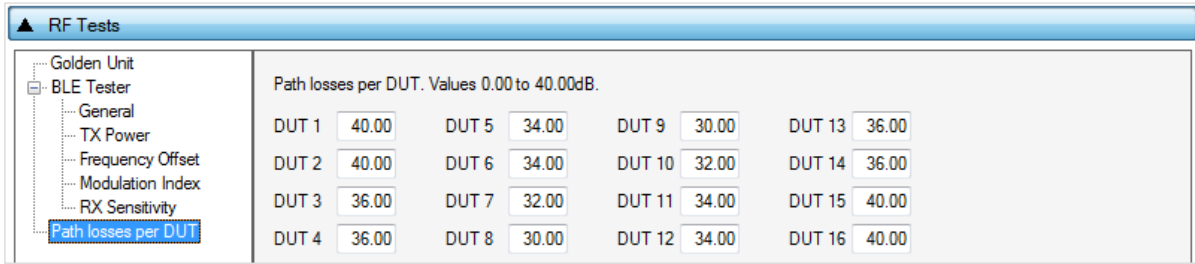

Figure 55. Path Losses per DUT

Table 39 describes the available options for the Path losses per DUT.

Based on the relative position of each DUT during RF tests and since the RF tests are performed over the air, values can be used to correct for any path losses. These values are added to the limits of the TX Power and RF RX RSSI tests. Additional information can be found in Appendix D and Appendix F.

Table 39. Path Losses per DUT from RF Tests Options

Option	Description
DUT1-16	Set the path loss value for each DUT. These are added as corrections to the limits of the TX Power and RF RX RSSI tests.

6.2.6.6 GPIO/LED Test

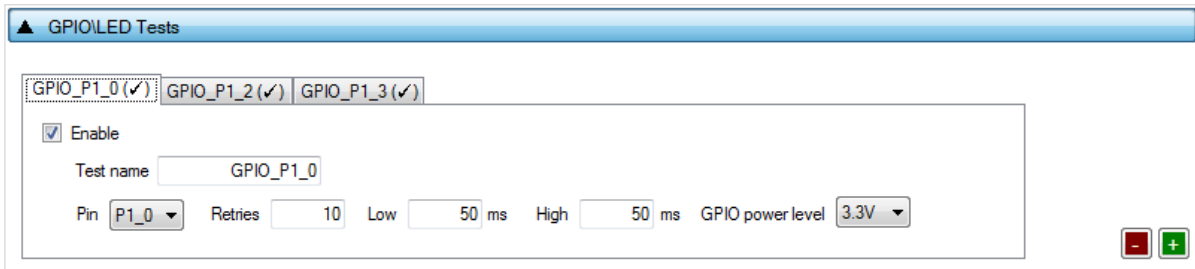

Figure 56. GPIO/LED Tests

GPIO/LED Tests can have multiple instances with different settings. Tests can be added or removed using the two buttons (for example, and in Figure 56) at the lower right side of each panel.

NOTE
When adding or removing a test, all settings are refreshed with the values written to the XML file, meaning that any unsaved settings are lost.

Table 40 describes the available options for the GPIO/LED Tests Options.

In these tests, a specific pulse can be given to a GPIO, and any LED connected to it can be visually tested. The **Pin** option sets the GPIO to be used, **Low** and **High** define the duty cycle and the **Retries** the number of pulses.

Table 40. GPIO/LED Tests

Option	Description
Enable	This option enables the GPIO/LED toggling. Can be used for visual LED testing.

SmartBond Production Line Tool

Option	Description
Test name	The name assigned to each test. The assigned name is shown on the tab and next to it an indication showing whether the specific test is enabled or not.
Pin	The GPIO that is used for the specific test.
Retries	Number of pulses to be generated for the specific test.
Low	Sets the amount of the OFF time of the pulse in ms for the specific test.
High	Sets the amount of the ON time of the pulse in ms for the specific test.
GPIO power level	Sets the power level of the GPIOs.

6.2.6.7 GPIO Connection Test

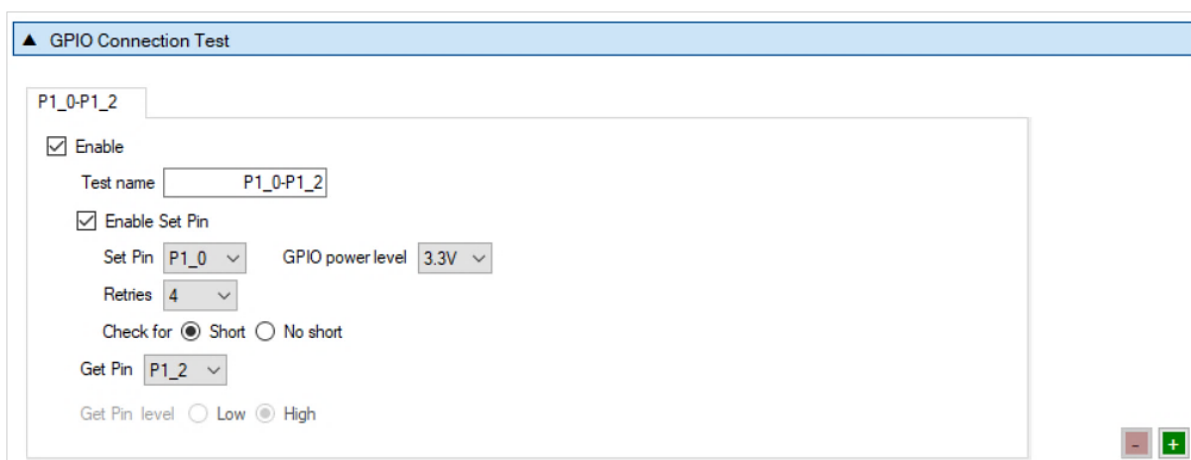



Figure 57. GPIO Connection Test

GPIO Connection Tests can have multiple instances with different settings. Tests can be added and removed using the two buttons (for example,  and  in Figure 57) at the lower right side of each panel.

NOTE
When adding or removing a test all settings are refreshed with the values written to the XML file, meaning that any unsaved settings are lost.

Table 41 describes the available options for the GPIO Connection Test.

When enabled, the PLT software checks the connection of the specified GPIO (*Get Pin*) by either checking its state or the connection with another pin (*Set Pin*). In the latter case, you give **Set Pin** and the state to check. It also checks for shorts between configured GPIOs.

Table 41. GPIO Connection Test

Option	Description
Enable	This option enables the specific custom test.
Test name	The name assigned to each test. The assigned name is shown on the tab and next to it an indication showing whether the specific test is enabled or not.
Enable Set Pin	Enables the use of the secondary GPIO to drive the GPIO under test. When this option is set, the Get Pin level option is disabled.
Set Pin	Select the GPIO to be tested

SmartBond Production Line Tool

Option	Description
GPIO power level	The output GPIO power level, 3.3 V or 1.8 V.
Retries	How many times the software checks for GPIO connection or short. In every retry it changes the Set Pin level and check the Get Pin level.
Check for Short/No short	If Short is selected, PLT checks whether the Set Pin has the same level with the Get Pin for all Retries tested. If No short is selected, PLT checks whether Get Pin is always low no matter what the Set Pin level is.
Get Pin	Select the GPIO to be tested.
Get Pin level	Sets the GPIO state the test awaits to see Get Pin . This option is disabled if the Set Pin mode is enabled.

6.2.6.8 Sensor Test

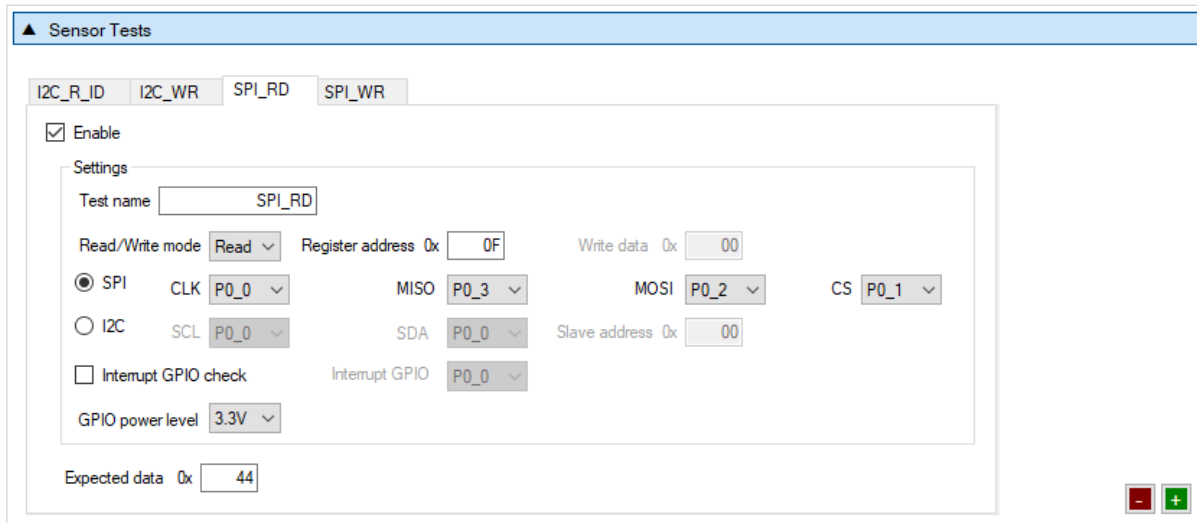

Figure 58. Sensor Test (SPI)

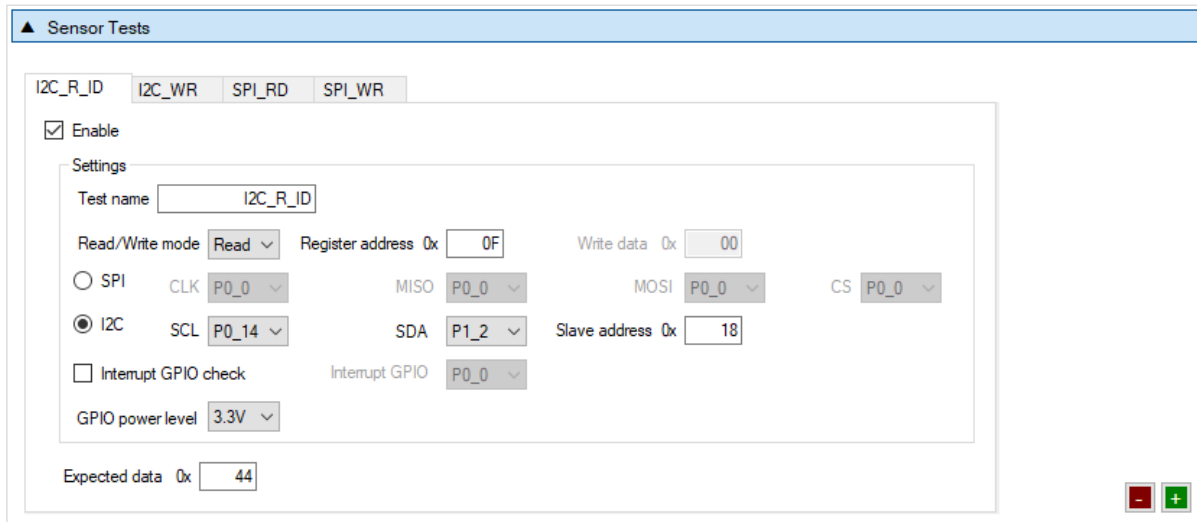



Figure 59. Sensor Test (I2C)

SmartBond Production Line Tool

Sensor Tests can have multiple instances with different settings. Tests can be added and removed using the two buttons (for example,  and  in Figure 58) at the lower right side of each panel.

NOTE
When adding or removing a test all settings are refreshed with the values written to the XML file, meaning that any unsaved settings will be lost.

Table 42 describes the available options for the Sensor Tests Options.

Table 42. Sensor Tests

Option	Description
Enable	This option enables the specific sensor test.
Test name	The name assigned to each test. The assigned name is shown on the tab and next to it an indication showing whether the specific test is enabled or not.
Read / Write mode	Select the sensor test procedure, to read or write.
Register address	The sensors register address to read or write data.
Write data	The byte to be written at the sensor register.
SPI / I2C	Select the interface that the sensor is connected to.
SPI - CLK	Select the GPIO for the sensor SPI CLK.
SPI - MISO	Select the GPIO for the sensor SPI MISO.
SPI - MOSI	Select the GPIO for the sensor SPI MOSI.
SPI - CS	Select the GPIO for the sensor SPI CS.
I2C - SCL	Select the GPIO for the sensor I2C SCL.
I2C - SDA	Select the GPIO for the sensor I2C SDA.
Slave address	The sensor I2C bus slave address.
Interrupt GPIO check	Enables the sensor interrupt signal test through GPIO.
Interrupt GPIO	Select the GPIO to be used as a sensor interrupt.
GPIO power level	Sets the power level of the GPIOs.
Expected data	The received sensor byte that is expected on a successful operation.

6.2.6.9 Custom Test

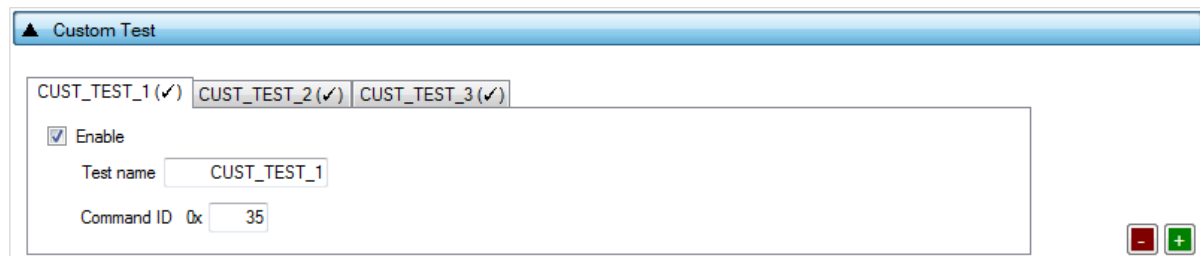



Figure 60. Custom Test

Custom tests can have multiple instances with different settings. Tests can be added and removed using the two buttons (for example,  and  in Figure 60) at the lower right side of each panel.

SmartBond Production Line Tool

NOTE
When adding or removing a test all settings are refreshed with the values written to the XML file, meaning that any unsaved settings are lost.

Table 43 describes the available options for the Custom Tests.

When enabled, the PLT software sends an HCI command through UART to activate a customer-defined test that runs on the DUTs. The HCI custom test command contains a single byte as data (the *Command ID* byte), to be used mainly as identification for a specific test in the firmware. Default functionality of the production test firmware is to respond with the same **Command ID**. Otherwise, the test is considered as failed.

Table 43. Custom Tests Options

Option	Description
Enable	This option enables the specific custom test.
Test name	The name assigned to each test. The assigned name is shown on the tab and next to it an indication showing whether the specific test is enabled or not.
Command ID	The byte that is sent to the device running the production test firmware.

6.2.6.10 External 32 kHz Test



Figure 61. External 32 kHz Test

Table 44 describes the available options for the External 32 kHz Tests.

Table 44. External 32 kHz Tests options

Option	Description
Enable	This option enables the external 32 kHz low power clock test.

6.2.6.11 Current Measurement Test

▲ Current Measurement Test

Current measurement general settings

Enable

Settings

Instrument ammeter_scpi.dll

Interface GPIO::16

Enable single DUT current measurement when failed

Peripheral Current Measurement

Periph Test 1

Enable

Test name

Single Device

Ammeter Setup

Settings

Shunt resistor 0.00 Ohms Wait time 2000 mSecs

Range 0.01 Amps Resolution 0.0001 Amps

Samples 10 SCPI cmd CURR:DC:NPLC 1

Limits per device

Upper limit <= 0.00 Amps

Low limit >= 0.00 Amps

Test Options

GPIO

GPIO Pin P0_0 GPIO state High GPIO power level 3.3V

PWM frequency 0 KHz PWM duty 0 %

Custom Test

Custom test

Start Command ID 0x 00 Stop Command ID 0x 00

Sleep Current Measurement

Enable

Settings

Single device

Sleep mode Extended Deep

Shunt resistor 0.00 Ohms Wait time 2000 mSecs Sleep time 5 Secs

Range 0.001 Amps Resolution 0.0001 Amps Up to 1200s of sleep time is supported.

Samples 10 SCPI cmd CURR:DC:NPLC 1

Limits per device

Upper limit <= 0.000002 Amps

Low limit >= 0.0000017 Amps



Figure 62. Current Measurement Tests

In this test, an external ammeter can be used to measure the total current consumption of all active DUTs. The ammeter can be connected in the blue banana plugs as described in Section 4.7 or to an external power supply (if present) depending the selected VBAT/Reset Mode (Section 6.2.2.6).

SmartBond Production Line Tool

During measurement, PLT controls the instrument using the `ammeter_driver` DLL Ref. [1]. Table 45 describes the instrument selection settings found by the `ammeter_driver` DLL, Table 46 describes the settings used for each of the peripheral current measurement tests and Table 47 describes the current measurement options for each sleep state.

NOTE
Modifications in the production test firmware are mandatory to achieve the correct current consumption of a specific hardware design (IC and peripherals) for each sleep state. Running the default firmware without any modifications specific for the hardware design, may cause increased current consumption.

Peripheral Current Measurement Tests can have multiple instances with different settings. Tests can be added and removed using the two buttons (for example,  and  in Figure 62) at the lower right side of each panel.

NOTE
When adding or removing a test, all settings are refreshed with the values written to the XML file, meaning that any unsaved settings are lost.

Table 45. Current Measurement Tests

Option	Description
Enable	This option enables all Current Measurement tests, which include: <ul style="list-style-type: none"> Peripheral current measurements Extended sleep current measurement Deep sleep current measurement Only one of the Extended/Deep sleep current measurements can be selected.
Instrument	Select the Ammeter instrument DLL name. Names are shown only if an ammeter DLL exists in the project <code>ammeter_instr_plugins</code> folder.
Interface	The interface of the instrument to be used by the driver.
Enable single DUT current measurement when failed	If this option is enabled and if the measurement taken is outside of the limits, PTL resets all devices and begin a firmware download and measure the current to each device separately, to identify which exact device failed.

Table 46. Current Measurement Test – Peripheral Current Measurement

Option	Description
Enable	This option enables the specific peripheral current measurement test.
Test name	The name assigned to each test. The assigned name is shown on the tab and next to it an indication showing whether the specific test is enabled or not.
Single Device	If this option is enabled, PLT measures the current consumption one device at the time. Initially, it powers off all DUTs. It then powers on one by one, download firmware and measure the current individually. This procedure takes a lot of time. It should only be used for production setup purposes, to identify the correct limits by measuring multiple DUTs and taking the average.
Shunt resistor	The value of the shunt resistor used for peripheral measurement. Applicable only if a voltmeter or a NI-DAQ is used to measure current instead of a DMM. Values from 0 to 9999 are supported.
Wait time	The time in ms the PLT waits before taking a current measurement, after it has sent an instruction to the DUTs to go into a specific sleep state. Supported values are 1 to 500000 ms.

SmartBond Production Line Tool

Option	Description	
Range	The range value in Ampere units that the ammeter operates. Supported values are 0 to 9999 and default value is 0.001 A. When the <code>ammeter_scpi.dll</code> is used, if this value is set to zero, the instrument uses the automatic range functionality.	
Resolution	The ammeter resolution value in Ampere units.	
Samples	The number of samples that the ammeter reads and averages. 1 to 1000 is supported.	
SCPI cmd	A SCPI command to be passed to the ammeter just before the measurement is taken. Supports multiple commands separated with a column. Up to 256 characters are supported.	
Upper limit	<p>The upper limit value of the peripheral current measurement test procedure, for a single DUT.</p> <p>Next to this input field the total upper limit current consumption for all the enabled DUTs is shown, which is the value to be used during testing.</p> <p>Note: During testing, some DUTs may fail until the current measurement test takes place. In that case, the PLT automatically re-calculates the total upper limit by using the value given for a single DUT multiplied with the number of the active DUTs at the time that the test runs.</p>	
Low limit	<p>The low limit value of the peripheral current measurement test, for a single DUT.</p> <p>Next to this input field the total upper limit current consumption for all the enabled DUTs is shown, which is the value to be used during testing.</p> <p>Note: During testing, some DUTs may fail until the current measurement test takes place. In that case, the PLT automatically re-calculates the total low limit by using the value given for a single DUT multiplied with the number of the active DUTs at the time that the test runs.</p>	
Test Options	<p>Select between a PWM GPIO test and custom test.</p> <p>Note: For the custom tests to work, a modified production test firmware must be created with tests that set the DUTs to specific states before the current measurement test. Each test must be assigned to a specific opcode. The custom tests are the exact same as in Section 6.2.6.9.</p>	
Test Options - GPIO	Pin	Sets the GPIO to toggle with the PWM pulse.
	GPIO state	Sets the active state of the GPIO.
	GPIO power level	Sets the power level of the GPIOs.
	PWM frequency	Sets the PWM frequency.
	PWM duty	Sets the PWM duty cycle.
Test Options – Custom Test	Start Command ID	The opcode of the custom test that sets the state of the DUT.
	Stop Command ID	The opcode of the custom test that restores the DUT to its original state.

Table 47. Current Measurement Test - Sleep Current Measurement

Option	Description
Enable	This option enables the sleep current measurement using the ammeter provided in the <i>Instrument</i> section.
Single Device	If this option is enabled, PLT measures the current consumption, one device at the time. Initially, it powers off all DUTs. It then powers on one by one, download firmware and measure the current individually. This procedure takes a lot of time. It should only be used for production setup purposes, to identify the correct limits by measuring multiple DUTs and taking the average.
Sleep mode	You can select either the Extended or the Deep sleep mode.

SmartBond Production Line Tool

Option	Description
Shunt resistor	The value of the shunt resistor used for sleep current measurement. Applicable only if a voltmeter or a NI-DAQ is used to measure current instead of a DMM. Values from 0 to 9999 are supported.
Wait time	The time in ms the PLT waits before taking a current measurement, after it has sent an instruction to the DUTs to go into a specific sleep state. Supported values are 1 to 500000 ms.
Sleep time (only for extended sleep)	The time in seconds that the DUTs remains in extended sleep mode. A timer in the production test firmware wakes up the devices and sets them to idle mode. Supported values are 1 to 9 s for DA14580/1/2/3 and up to 1200 s for the rest.
Range	The range value in Ampere units that the ammeter operates. Supported values are 0 to 9999 and default value is 0.001 A. When the <code>ammeter_scpi.dll</code> is used, if this value is set to zero, the instrument uses the automatic range functionality.
Resolution	The ammeter resolution value in Ampere units.
Samples	The number of samples that the ammeter reads and averages. 1 to 1000 is supported.
SCPI cmd	A SCPI command to be passed to the ammeter just before the measurement is taken. Supports multiple commands separated with a column. Up to 256 characters are supported.
Upper limit	The upper limit value for the sleep current measurement test procedure, for a single DUT. Next to this input field the total upper limit current consumption for all the enabled DUTs is shown, which is the value to be used during testing. Note: During testing, some DUTs may fail until the current measurement test takes place; in that case, the PLT automatically re-calculates the total upper limit by using the value given for a single DUT multiplied with the number of the active DUTs at the time that the test runs.
Low limit	The low limit value for the sleep current measurement test procedure, for a single DUT. Next to this input field the total upper limit current consumption for all the enabled DUTs is shown, which is the value to be used during testing. Note: During testing, some DUTs may fail until the current measurement test takes place; in that case, the PLT automatically re-calculates the total low limit by using the value given for a single DUT multiplied with the number of the active DUTs at the time that the test runs.

6.2.6.12 Temperature Measurement Test

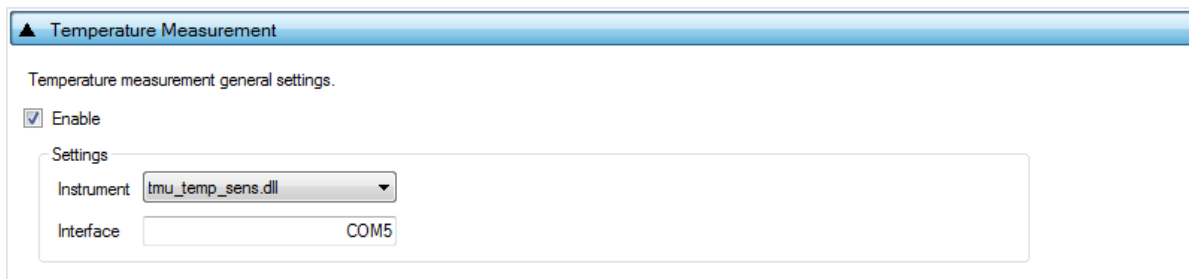

Figure 63. Temperature Measurement Test

SmartBond Production Line Tool

Table 48 describes the available options for the Temperature Measurement Test.

Table 48. Temperature Measurement Test

Option	Description
Enable	This option enables the Temperature measurement test.
Instrument	Select the Temperature measurement DLL. Names are shown only if a Temperature measurement instrument DLL exists in the project folder <code>temp_meas_instr_plugins</code> .
Interface	The interface of the instrument to be used by the driver.

6.2.6.13 Scan Test

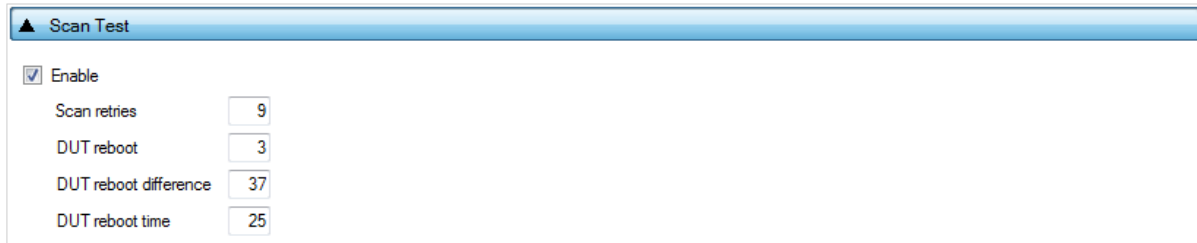

Figure 64. Scan Test

Table 49 describes the available options for the Scan Test.

By enabling this test, the Golden Unit scans for the DUT's BD addresses advertised after the customer firmware is programmed to the DUT. For this test to work, a bootable firmware with the ability to advertise with the BD address given by the PLT must be burned into each DUT. Additionally, the BD addresses provided by the PLT should be burned into CS memory such that the devices advertise with the BD addresses the tool uses.

Table 49. Scan Test options

Option	Description
Enable	This option enables the Scan test.
Scan retries	The total number of Bluetooth® LE advertising scans the Golden Unit performs.
DUT reboot	Define after how many retries the PLT reboots the DUTs.
DUT reboot difference	Set the time difference between each DUT when the PLT reboots the devices, in order to avoid air collisions.
DUT reboot time	The time the VBAT remains low during the device reboot. This value is time in ms*100 (for example, 15 is 1500 ms).



SmartBond Production Line Tool

6.2.7 Memory Functions

This section describes the Memory Functions settings available when using devices. Memory functions include EFLASH and QSPI flash memory programming.

6.2.7.1 Flash Memory

Figure 65. Flash Memory

This section describes how the EFLASH and QSPI Flash memory can be erased and programmed. Both erase and write operations can have multiple instances with different settings. Tests can be added and removed using the two buttons (for example,  and  in [Figure 65](#)) at the lower right side of each panel.

NOTE

When adding or removing a test all settings are refreshed with the values written to the XML file, meaning that any unsaved settings are lost.

The QSPI flash memory should be erased before any image is written to it. [Table 50](#) describes the available options for the QSPI Flash Erase operation.

Table 50. QSPI Flash Erase

Option	Description
Erase enable	This enables the specific QSPI flash erase test.
EFLASH/QSPI	EFLASH refers to the embedded FLASH on the IC. QSPI refers to the QSPI interface using a QSPI compatible flash.
Entire memory	This option is only available for the <i>Erase enable</i> option. When this checkbox is selected, the entire memory can be erased. Otherwise, you can give a start address and a specific number of bytes to be erased. Note: On DA1459x devices FLASH memory also includes special areas such as the configuration script area and application keys are. By erasing the entire memory these areas are erased as well.

SmartBond Production Line Tool

Option	Description
Start address	You can enter a specific start address for the QSPI erasure to start.
Size	The size in bytes to erase, starting from the Start address .

After every EFLASH/QSP Flash erase test has finished, the EFLASH/QSPI image write tests begins. [Table 51](#) describes the available options for the EFLASH/QSPI Flash Image Write operation.

Table 51. Flash Image Write

Option	Description
Write enable	This enables the specific EFLASH or QSPI flash image programming test.
EFLASH/QSPI	EFLASH refers to the embedded FLASH on the IC. QSPI refers to the QSPI interface using a QSPI compatible flash.
Verify image	By selecting this option, the PLT software reads back the contents of the flash memory and compares them to the original image file. If these do not match, the memory programming fails.
Start address	You can configure the flash start address where the image is written.
Image path	Through this field, you can specify the image file to be burned into the flash memory. A .bin binary file of any name can be selected.

6.2.7.2 Memory Read

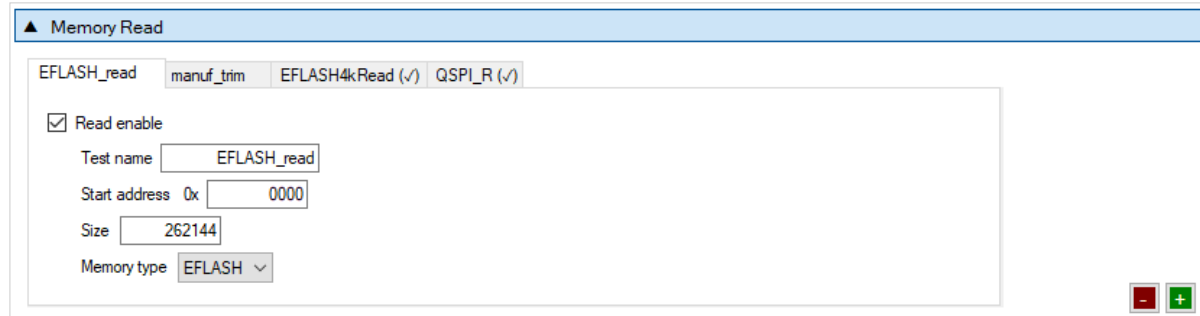



Figure 66. Memory Read test

Memory Read Tests can have multiple instances with different settings. Tests can be added or removed using the two buttons (for example,  and  in [Figure 66](#)) at the lower right side of each panel.

NOTE
When adding or removing a test, all settings are refreshed with the values written to the XML file, meaning that any unsaved settings are lost.

[Table 52](#) describes the memory read test options. With this test, you can read up to 64 MB of data from any address from any available memory for the devices, such as EFLASH and QSPI. An example of how the data appears on the log file is shown in [Figure 67](#).

```
Memory read operation initialized. Memory read test name=[QSPI_CUSTOM].
Memory read operation started. Memory read test name=[QSPI_CUSTOM].
Memory read operation ended OK. Test name [QSPI_CUSTOM]. Memory=[QSPI]. Addr=[0xE1000]. Size=[5]. Data=[1122334455].
```

Figure 67. Memory Read test example log file

SmartBond Production Line Tool

Table 52. Memory Read test

Option	Description
Read enable	This enables the specific memory reading test.
Test name	The name assigned to each test. The assigned name is shown on the tab and next to it an indication showing whether the specific test is enabled or not.
Start address	Configures the start address.
Size	Number of bytes to read, up to 64 MB. If data to be read are greater than 256 bytes, then a file is created to store the data under folder <code>mem_read_test</code> in the PLT execution path.
Memory type	The type of memory to read the data from. Available options are QSPI or EFLASH.

6.2.8 Memory header

This section describes the Memory Header programming settings (EFLASH or QSPI), available in devices.

6.2.8.1 Custom Memory Data

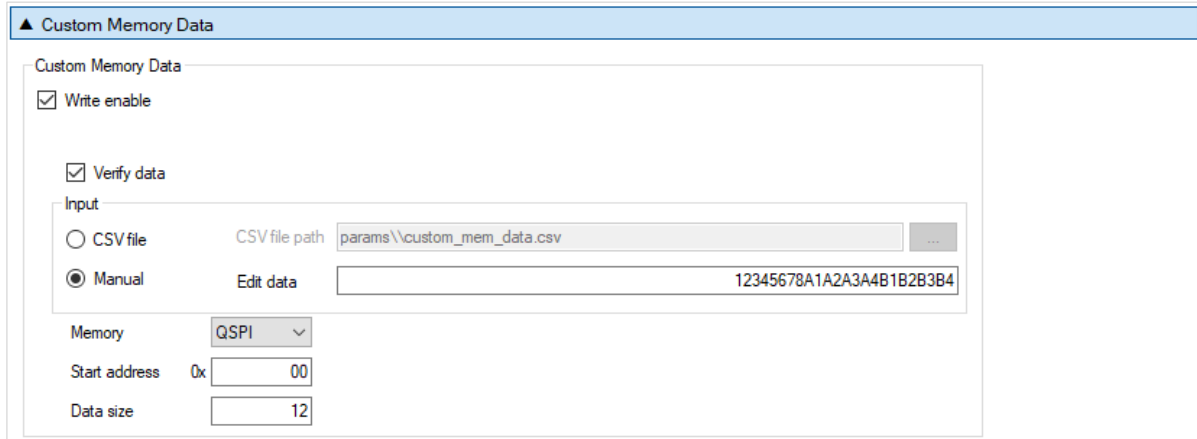

Figure 68. Custom Memory Data

Table 53 describes the Custom Memory data test options. With this test, you can write any data to any address to any available memory for the devices, such as EFLASH, register initialization at CS section and QSPI. Data input modes can be a CSV file or manually entered data.

Table 53. Custom Memory Data

Option	Description	
Write enable	This option enables the Custom data programming.	
Verify data	When selected, the data written is read back from the memory and is compared to the original.	
<ul style="list-style-type: none"> • CSV file • Manual data 	CSV file path (CSV file)	Path to the CSV file containing data for each device discriminated using BD addresses. The CSV file format is described in Section 5.10.1.
	Edit data (Manual data)	Hexadecimal data input of up to 256 bytes to burn. These data are burned to all active DUTs.
Memory (Manual data mode)	Memory type selection to burn the data. Available options are EFLASH and QSPI (only with Manual data).	

SmartBond Production Line Tool

Option	Description
Start address (available with Manual data mode)	Memory address offset to begin burning the data.
Data size (available with Manual data mode)	The size of the memory data to burn. The size is number of bytes.

6.2.8.2 Configuration Script

▲ Configuration Script

Configuration Script

Enable

No check
 Error if command exists
 Skip if entry exists
 Skip if command exists

Verify data

Configuration Script Memory: EFLASH ▾

Booter Value - 0x60001000

Write

Address in flash 0x 0001000

Development Mode - 0x70000000

Disable development mode

UART STX - 0x89000123

Write

Timeout 0x 000123

Boot baud rate 230400 ▾

SDK Value - 0x9000YYXX-0XXXXXXXXX

BD address - 0x9000020B

Write

SW generated - 0x9000YY30

Enable

Set ID 0x 00 Group ID 0x 30

⚠ If enabled, the values for this SDK group will be generated by the PLT software. By default, PLT writes the current date in ASCII format. To write something else, the PLT software should be modified.

0x90000119

Enable

Set ID 0x 00 Group ID 0x 19 Length 0x 01

12345678

■ ■

XTAL settle - 0xA0003344

Write

Timeout 0x 003344

Ignore settle Disable settle ▾

Figure 69. Configuration Script (part 1)

SmartBond Production Line Tool

The screenshot shows a configuration interface with several sections:

- Minimum firmware version - 0xB0000002**: Includes a 'Write' checkbox and a 'Minimum version' field with the value '0000002'.
- Set Once Bits Configuration - 0xC0000001**: Includes a 'Write' checkbox and a 'Value' field with the value '0001'.
- Register configuration - 0x5YYYYYYY-0xFFFFFFFF**: Contains two rows. Each row has an 'Enable' checkbox, a value field (50000000 and 50000007), a hex field (0ABCDEF1 and 00000034), and a red '-' button. The second row also has a green '+' button.
- XTAL trim - 0x50010008-0xFFFFFFFF**: Includes a 'Write' checkbox.
- Stop command - 0x00000000**: Includes a 'Write' checkbox.

Figure 70. Configuration Script (part 2)

The Configuration Script is an area used for programming system registers with values that are defined during production testing, store a trim value for the application software or define UART time out time during booting. It is executed by the booter to prepare and initialize the system prior to the CPU start running application code from the non-volatile memory (EFLASH, QSPI Flash, and so on).

The Configuration Script is a table of 32-bit entries, 256 spaces deep making a total size of 1024 bytes.

The Configuration Script comprises ten different **commands**. The CS begins with the Start command followed by a set of commands that refer to certain things, like register configurations, trim values, and so on. The CS ended with the Stop command. Empty entries between commands are not allowed. If an empty entry is found, then all the following commands should be discarded. The commands are depicted in [Table 54](#).

Table 54. Configuration Script commands

#	Command	Command header	# of Words following
1	Start of CS	0xA5A5A5A5	0
2	Register Configuration	Register Address	1
3	Booter Value	0x60000000	0
4	Development Mode Disable	0x70000000	0
5	Boot UART Configuration	0x8YYYYYYY	0
6	SDK Trim Value	0x9000YYXX	1 – 0xFF
7	XTAL configuration	0xAFFFFFFFF	0
8	Minimum firmware version	0xBFFFFFFFF	0
9	Set-Once Bits Configuration	0xCFFFFFFFF	0
10	Stop of CS	0x00000000	0

[Table 55](#) explains the PLT available parameters for programming the CS.

SmartBond Production Line Tool

Table 55. Configuration Script

Option	Command	Description
Enable	-	When selected, Configuration Script options are enabled.
<ul style="list-style-type: none"> No check Error if command exists Skip if entry exists Skip if command exists 	-	Configuration Script memory protection options: <ul style="list-style-type: none"> No check: Check disabled. Error if command exists: Returns error if the command of an entry is already written in the DUT, no matter if the data are the same. Skip if entry exists: Skip writing an entry without error if the command and the data are already written in the DUT. If same command is found with different data an error is returned. Skip if command exists: Skip writing without returning error if the command in the DUT CS is already written, no matter what the data are (same or different).
Verify	-	Verify the written data.
Configuration Script Memory	EFLASH/ QSPI	Select the memory that the Configuration Script is going to be read/written from. Default and for most operations the Configuration Script is stored in the CS area for the EFLASH 0x0000 – 0x03FF.
Booter value	0x6XXXXXXX	The Booter Value command consists of one 32-bit word. The first 4 msb are equal to 6 the following 3.5 byte are used to indicate the Flash product header address in flash follows. If the Booter Value command exists multiple times within the CS, the booter executes the command as many times as the command exists resulting in using only the last encountered value.
Development mode	0x70000000	The Development Mode command consists of one 32-bit word which is equal to 0xE7000000, instructing the booter to disable the development mode. There is no limitation for the number of entries the Development Mode command exists in the CS, thus the first entry should only be considered by the booter.
UART STX	0x8YXXXXXX	The UART STX command consists of one 32-bit word which is equal to 0x8YXXXXXX. The XXXXX is used to program the selected STX timeout in multiples of 100 μs. So that, 0x80000028 is 40x100 μs = 4 ms. The Y is used to select one of the predefined UART baud rates.
SDK value	0x9000YYXX	The Trim Value command consists of one 32-bit word which is equal to 0xE900YYXX indicating that the next word is a value stored during production testing, followed by one (or more) 32-bit word(s) which represent the value(s). More specifically: <ul style="list-style-type: none"> E9: indicates that the following word(s) are not to be stored to registers but are used by the SDK software YY: indicates that 0xYY number of words follow XX: is an index (Group ID) and can be used for different parameters by the software application. The maximum number of Group IDs per Set ID is 256. The Group IDs are used for production or other data, for example, BD address, preferred value, or function coefficients.
BD address	0xE900020B	If this option is selected, PLT burns the BD address to the CS with command 0xE900020B, which is the appropriate Group ID for SDK BD address.
SW generated	0x9000YY30	If enabled, PLT software burns the current date in ASCII format in PLT CS. The default Group ID is set to 0x30. These can be changed. Additionally, PLT software can be modified to write something different than then current date.

SmartBond Production Line Tool

Option	Command	Description
XTAL settle	0xA0000000	<p>One 32-bit word which is equal to 0xAYXXXXXX. The XXXXXX is used to program the selected XTAL32M settling time in multiples of 100 μs. So, 0xA0000028 is 40x100 μs = 4 ms.</p> <p>The Y is used to instruct the booter to overrule the XTAL32M settling and:</p> <p>Y = 1: Ignore XTAL32M settling time and continue.</p> <p>Y = 2: Ignore XTAL32M settling time and continue booting using RC32M.</p>
Minimum firmware version	0xBXXXXXXX	The Minimum firmware version command consists of One 32-bit word containing the 0xBXXXXXXX, where XXXXXXXX is used to store the minimum firmware version that the booter should accept.
Set-Once Bits Configuration	0xCXXXXXXX	<p>One 32-bit word containing the 0xC000XXXX where the XXXX is used to program the set-once (sticky) bits for hardware configuration and security features. Bits:</p> <p>0: PROT_CONFIG_SCRIPT 1: PROT_APP_KEY 2: PROT_VALID_KEY 3: PROT_USER_APP_CODE 4: Enable DCDC at boot 5: FORCE_M33_DEBUGGER_OFF 6: FORCE_CMAC_DEBUGGER_OFF 7: SECURE_BOOT</p> <p>Rest: Reserved.</p>
Register Configuration		<p>If this option is enabled, you can program in CS a value that is set to a specific register during boot. It contains:</p> <ul style="list-style-type: none"> • A 32-bit word containing an address of an existing register • A 32-bit word containing the data value of the register. <p>These are always in pairs with the address sitting in even memory addresses.</p>
Register configuration	0x5YYYYYYY	<p>The Register Configuration command consists of one 32-bit word containing an address of an existing register within the available memory map range, followed by a second 32-bit word containing the data value of the register. These words are always in pairs.</p> <p>If the Register configuration command for a specific register exists multiple times within the CS, the booter executes the command as many times as the command exists resulting with the specific register having the value the last command instructed. The SDK should also make sure that the last value is considered as valid.</p>
XTAL trim	0x50010008	The XTAL trim calibration value found in Section 6.2.6.3 is programmed in CS. The value found in the XTAL trim calibration process is applied to register 0x50010008.
Stop command	0x00000000	The Stop of CS command consists of one 32-bit word (0x00000000), designating that the configuration script has reached the end and execution should be terminated. It should be noted that there is no limitation for the number of entries the Stop command exists in the CS, thus the first entry is only considered by the booter. Apart from the minimum firmware version entries that is evaluated by the booter at all times, all other commands after the first entry of the Stop command are discarded.

SmartBond Production Line Tool

6.2.9 Debug Settings

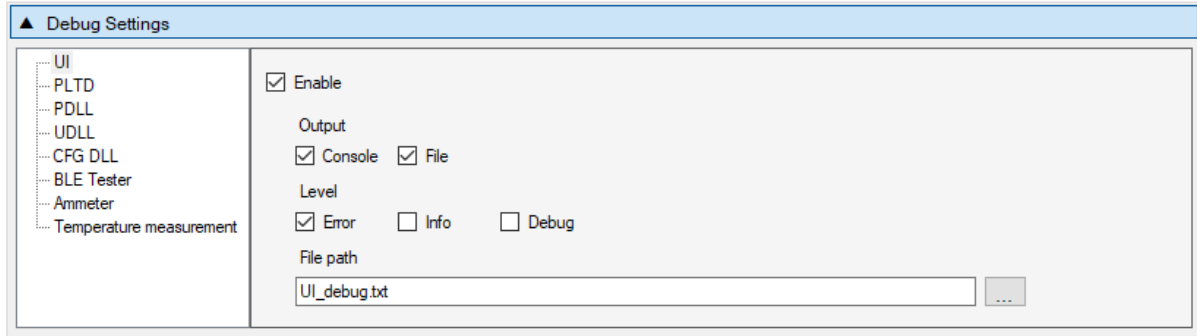

Figure 71. Debug Settings

Table 56 describes the available options for the Debug Settings. Debug messages are available in all PLT software blocks shown in Figure 18.

NOTE
Printing debug information may introduce system delay and thus some tests may fail due to time out expirations. We suggest having debug information disabled in all software blocks and only partially enable when there is a real need for it. From PLT v4.0 and onwards, this system delay is almost eliminated as debug print messages are printed from a lower priority queue. It is safer, but it is still suggested to have the debug prints disabled.

Table 56. Debug Settings

Option	Description
Enable	Enable debug message prints for the selected library or UI.
Output - Console	Sends the debug messages to the <code>stdio</code> output. The PLT CLI does not support this option. If enabled, debug messages is redirected to the equivalent files.
Output - File	Save the debug messages to a file.
Level - Error	Enable error debug level messages. All debug print messages marked as error are printed.
Level - Info	Enable info debug level messages. All debug print messages marked as info are printed.
Level - Debug	Enable low level debug level messages. All low-level debug print messages are printed.
File path	Select the file that the debug messages are saved. The file should exist; otherwise, it should be created manually. Used only when the option Output - File is selected.

SmartBond Production Line Tool

6.2.10 Security

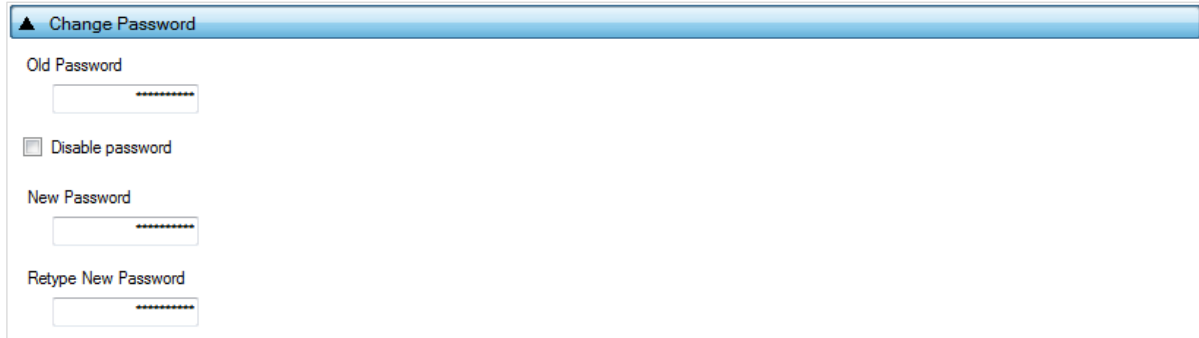

Figure 72. Security

In this field, a password can be set to protect specific tool actions, such as:

- Opening the CFG PLT or the GUI PLT application.
- Closing the CFG PLT or the GUI PLT application.
- Opening or refreshing configuration settings in the GUI PLT application.
- Opening the settings menu in the GUI PLT application.

Table 57 describes the available options for the Security options.

Table 57. Security options

Option	Description
Old Password	Type the current password to enable changing of the following fields.
Disable Password	This option disables the password usage.
New Password	Type a new password.
Retype New Password	Verify the new password.

6.3 GUI PLT application

The GUI PLT (`SmartBond_PLT_GUI.exe`) is a Graphical User Interface application that performs the device validation and programming process. At the same time, it allows you to monitor the entire procedure in detail. The GUI PLT uses the same XML file configured from CFG PLT as described in Section 6.2.

NOTE
If a change is made to the XML file from the CFG PLT, then the GUI PLT settings should be refreshed as described in Table 58.

Figure 73 shows the initial window of the GUI PLT, which is described in Table 58.

SmartBond Production Line Tool

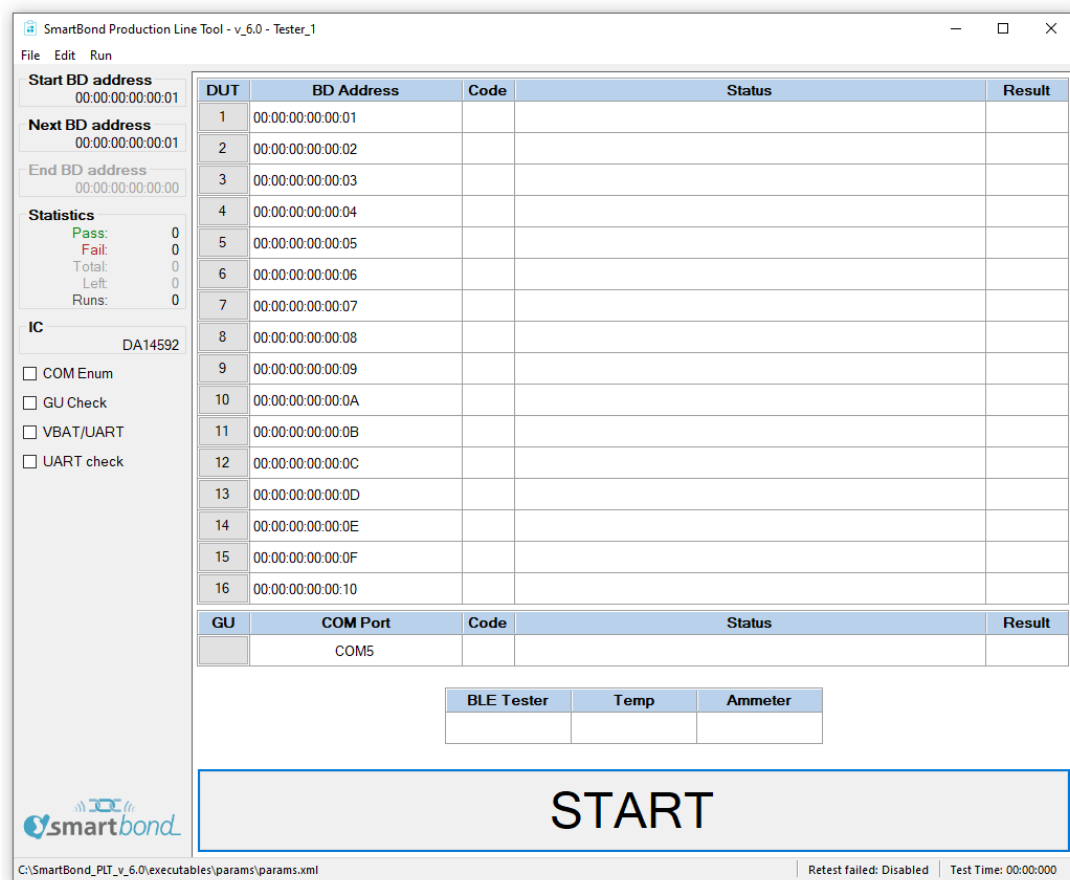

Figure 73. GUI PLT Main window

Table 58. GUI PLT Main window description

Options	Description
File options	
File > Open XML file	Opens a new XML file and loads its settings. The full path of the new XML file is shown at the lower left of the window.
File > Refresh XML file	Reloads the settings from the XML file and initializes itself with the new settings.
File > Open CSV file	Contains a list with all the available CSV files to open.
File > Exit	Exits the GUI PLT application.
Edit options	
Edit > Settings	Opens the GUI PLT Settings window (Section 6.3.1).
Run options	
Run > Run Configuration PLT	Opens the CFG PLT application.
Left Column options	
Start BD Address	The BD address the PLT session started with, as described in Section 6.2.4.
Next BD Address	The BD address that is used on the BD address assignment for the next run as described in Section 6.2.4.

SmartBond Production Line Tool

Options	Description
End BD Address	The BD address the PLT session ends with as described in Section 6.2.4. This option is available only when <i>Range mode</i> is enabled.
Statistics	This field holds statistics for each PLT session. Table 24 describes the <i>Statistics</i> field.
IC	The selected IC of the PLT.
COM Enum	If this checkbox is enabled, then the START button initiates the automatic Window COM port enumeration for the DUT.
GU Check	If this checkbox is enabled, then the START button initiates the automatic Window COM port enumeration for the Golden Unit.
VBAT/UART	If this checkbox is enabled, then the START button enables the VBAT and UART for the DUTs selected under <i>VBAT/UART</i> in Table 59.
UART check	If this checkbox is enabled, then the START button initiates the UART check procedure for the DUTs with a specified Baud rate set from the user through the GUI PLT Settings (Section 6.3.1). During this test, 1000 packets are sent, received back, and checked for errors. The packets contain 252 bytes. Note: Before any UART transfer begins, PLT downloads the production test firmware to the active DUTs.
Center window options	
DUT panel	Shows the following fields for each DUT: <ul style="list-style-type: none"> ● DUT: DUT connector number on the PLT hardware. This field is also a button that opens the Log file for the specific DUT. ● BD Address: BD address assigned to the DUT. ● Code: Real-time status as a PLTD DLL special code described in Ref. [1]. ● Description: A brief description of the status code. ● Result: Simplified color-coded status showing the progress per DUT.
GU panel	Shows the following fields for the Golden Unit: <ul style="list-style-type: none"> ● GU: A button that opens the Golden Unit Log file. ● COM Port: The COM port assigned to the Golden Unit. ● Code: Real-time status as a PLTD DLL special code described in Ref. [1]. ● Status: A brief description of the status code. ● Result: Simplified color-coded status showing the progress of the GU.
Instrument panel	This field shows a simplified color-coded status is shown for each of the instruments (BLE Tester , Temp , Ammeter and Voltmeter), if they are enabled.

SmartBond Production Line Tool

Options	Description
START button	If one of the options (COM Enum , GU Check , VBAT/UART or UART check) is enabled, then selecting the START button initiates the chosen test. If no option is selected, selecting the START button initiates the production procedure. Note: To select and click the START button, press Spacebar. To return to main window after the selected procedure is finished, click the Start button or use the F7 key as a shortcut, . This is to avoid clicking the Start button and starting a new test procedure, by mistake.
Bottom of the main window	
Left panel: C:\SmartBond_PLT_v_6.0\executables\params\params.xml	Shows the full path of the XML file that is currently used.
Center panel: Retest failed: Disabled	Shows if the re-test option in Section 6.3.1 is enabled.
Right panel: Test Time: 00:00:000	This timer starts counting when the START button is clicked and runs until the PLT returns to its idle state, showing the approximate duration of the tests.

6.3.1 GUI PLT settings

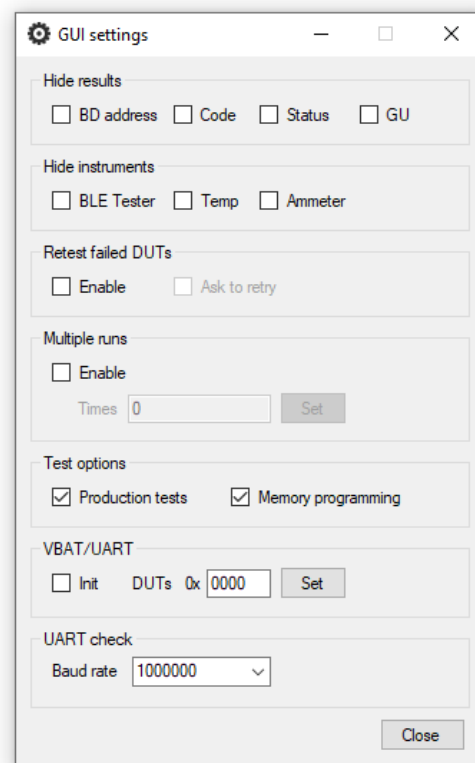

Figure 74. GUI PLT settings

Figure 74 shows the GUI PLT settings window. In this window, various graphic options and features can be set as described in Table 59.

SmartBond Production Line Tool

Table 59. GUI PLT settings

Field	Option	Description
Hide results	BD address	Hides the <i>BD address</i> column in the DUT panel of the GUI PLT.
	Code	Hides the <i>Code</i> column in the DUT panel of the GUI PLT.
	Status	Hides the <i>Status</i> column in the DUT panel of the GUI PLT.
	GU	Hides the <i>GU</i> column in the DUT panel of the GUI PLT.
Hide instruments	BLE Tester	Hides the <i>BLE Tester</i> column in the GU panel of the GUI PLT.
	Temp	Hides the <i>Temp</i> column in the GU panel of the GUI PLT.
	Ammeter	Hides the <i>Ammeter</i> column in the GU panel of the GUI PLT.
Retest failed DUTs	Enable	If this option is enabled, any DUT that failed during the main procedure immediately re-runs the tests having the exact same options including the <i>BD address</i> assigned to it. This option is the exact same option as <i>Re-test failed DUTs</i> in Section 6.2.3.2.
	Ask to retry	Shows a message asking to do a re-test in case any DUT failed. If this option is disabled, the re-testing is done automatically.
Multiple Runs	Enable	By enabling this option, the GUI PLT performs multiple procedures without any delay between them. This is used for only for evaluation.
	Times	The number of times to run.
Test Options	Production tests	Enables/Disables the production test procedure. This is the same option as <i>Production tests</i> in Section 6.2.3.2.
	Memory programming	Enables/Disables the production test procedure. This is the same option as <i>Memory programming</i> in Section 6.2.3.2.
VBAT/UART	Init	If this option is enabled, the PLT hardware is reset before enabling the DUTs. This option is enabled only when <i>VBAT/UART</i> in the main window is enabled.
	DUTs	Bitwise DUT set/reset for each of the 16 DUTs using a 16-bit hexadecimal value. Example: To enable only DUTs 1, 2, 15, and 16 use "C003" (1100 0000 0000 0011 = 0xC003).
UART check	Baud rate	Sets the Baud rate for the UART check test.

6.3.2 Running the GUI PLT and executing tests

The GUI PLT starts the test procedure when you click the **START** button. Before initiating the test procedure, the GUI PLT assigns BD addresses to the active DUTs and checks for any wrong configuration parameters.

If `Run scripts before testing` starts is enabled, PLT executes the selected script/executable, and waits until it finishes or times out, depending on the selections made in Section 6.2.3.2. If the script/executable returns on time, PLT checks the return code. Values from 0 to 100 indicate a successful completion. Negative values or values larger than 100 indicate an error. In the case of an error (either time out or error returned result), a pop-up message appears indicating the return code and the test procedure does not start.

SmartBond Production Line Tool

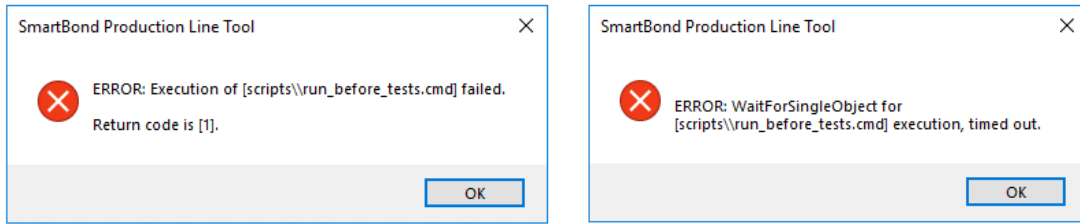

Figure 75. GUI PLT - erroneous messages in Run Scripts Before Testing Starts

If any CS writing test is scheduled, a pop-up message informs you and prompts to continue (Figure 76).

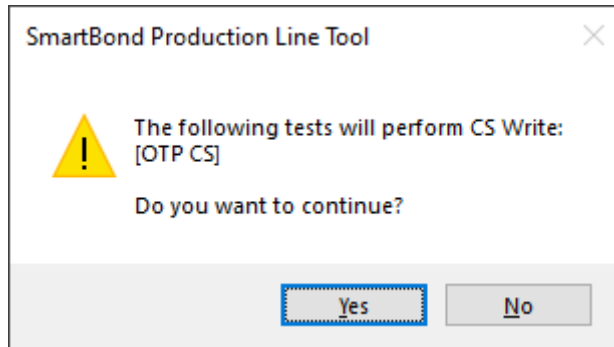

Figure 76. GUI PLT CS Write warning message

To start the testing procedure, click **Yes**. PLT updates the status of the procedure for each DUT and the Golden Unit (Figure 77). The **START** button is replaced by a progress bar indicating the progress of the tests.

SmartBond Production Line Tool

The screenshot shows the SmartBond Production Line Tool interface. On the left, there are control panels for 'Start BD address' (48:23:35:AA:BB:01), 'Next BD address' (48:23:35:AF:9F:B6), 'End BD address' (00:00:00:00:00:00), 'Statistics' (Pass: 18829, Fail: 35, Total: 0, Left: 0, Runs: 1180), 'IC' (DA14592), and 'Multiple Runs' (Current: 1179, Total: 5000). There are also checkboxes for 'COM Enum', 'GU Check', 'VBAT/UART', and 'UART check'. Below these is a 'smartbond' logo.

DUT	BD Address	Code	Status	Result
1	48:23:35:AF:9F:A6	9	FW DOWNLOAD STARTED	
2	48:23:35:AF:9F:A7	9	FW DOWNLOAD STARTED	
3	48:23:35:AF:9F:A8	9	FW DOWNLOAD STARTED	
4	48:23:35:AF:9F:A9	9	FW DOWNLOAD STARTED	
5	48:23:35:AF:9F:AA	9	FW DOWNLOAD STARTED	
6	48:23:35:AF:9F:AB	9	FW DOWNLOAD STARTED	
7	48:23:35:AF:9F:AC	9	FW DOWNLOAD STARTED	
8	48:23:35:AF:9F:AD	9	FW DOWNLOAD STARTED	
9	48:23:35:AF:9F:AE	9	FW DOWNLOAD STARTED	
10	48:23:35:AF:9F:AF	9	FW DOWNLOAD STARTED	
11	48:23:35:AF:9F:B0	9	FW DOWNLOAD STARTED	
12	48:23:35:AF:9F:B1	9	FW DOWNLOAD STARTED	
13	48:23:35:AF:9F:B2	9	FW DOWNLOAD STARTED	
14	48:23:35:AF:9F:B3	9	FW DOWNLOAD STARTED	
15	48:23:35:AF:9F:B4	9	FW DOWNLOAD STARTED	
16	48:23:35:AF:9F:B5	9	FW DOWNLOAD STARTED	

GU	COM Port	Code	Status	Result
	COM16	40	RD TESTER VBAT/UART OK	OK

BLE Tester	Temp	Ammeter
NOT USED	NOT USED	NOT USED

At the bottom, the status bar shows 'Retest failed: Disabled' and 'Test Time: 00:03:998'.

Figure 77. GUI PLT testing (1 of 2)

If an error in a DUT is found (Figure 78), PLT shows the status code, a brief description of the error and the color of the DUT's status line turns red. The DUT number button can be clicked anytime to access the DUT Log File (Section 6.3.4) to get more details about the parameters used, calculated values and the reason for failure in the case of an error.

SmartBond Production Line Tool

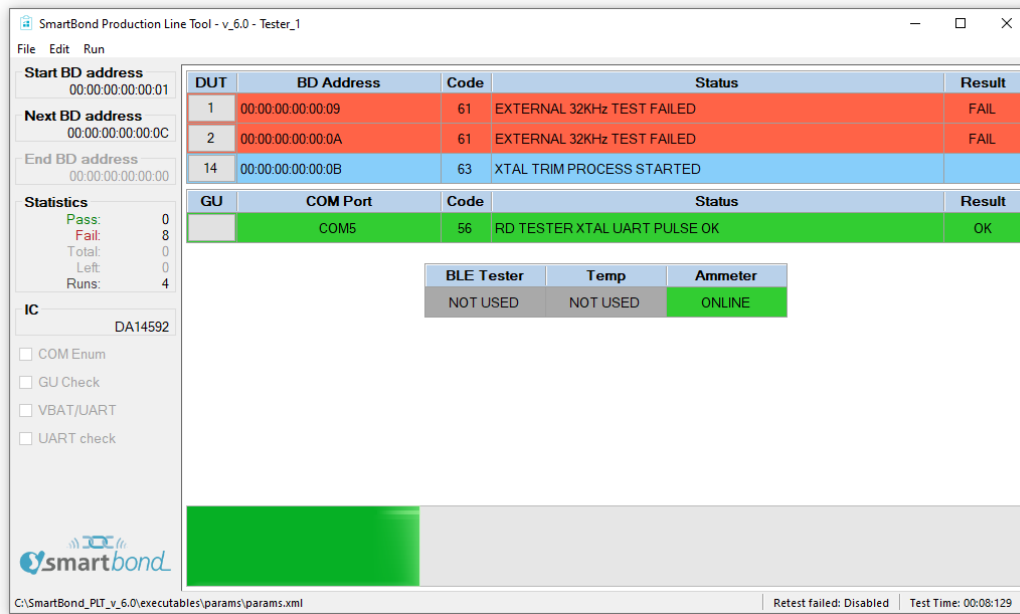

Figure 78. GUI PLT testing (2 of 2)

After the testing procedure is completed (Figure 79), the progress bar shows **FINISHED** and the color turns red if any DUT failed, otherwise it is green. If there is an error and the *Retest failed DUTs* option is enabled, the GUI PLT performs a retest run, all options (including the BD addresses) remain the same and only tests that failed are retested. At this time, the CSV File (Section 6.3.5) and all the DUT Log Files (Section 6.3.4) are updated.

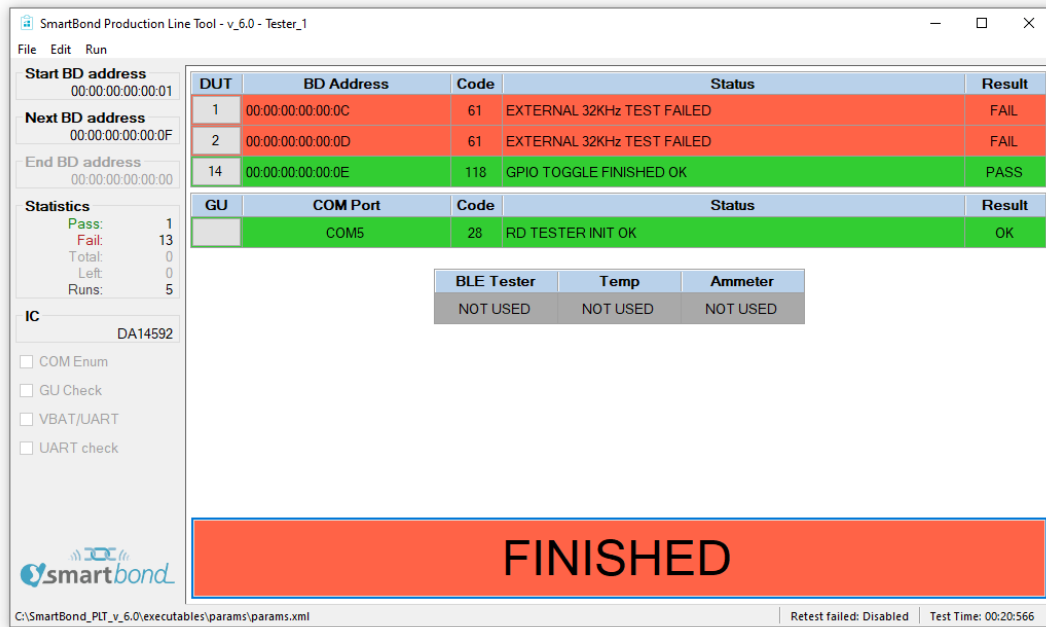

Figure 79. GUI PLT tests finished

If the DUT fails again, after the retest has finished the GUI PLT remains in the *FINISHED* window (Figure 79) with the **FINISHED** button shown in red.

SmartBond Production Line Tool

If Run scripts when testing is finished is enabled, clicking the **FINISHED** button executes the selected script/executable. As with Run scripts before testing starts, PLT waits until it finishes or times out, depending on the selections made in Section 6.2.3.2. If the script/executable returns on time, PLT checks the return code. Zero value indicates a successful completion. Any other value is considered an error. In the case of an error (either time out or error result), a pop-up message appears indicating the return code.

6.3.3 Debug console

Section 6.2.8.1 shows the debug settings for all PLT applications including the GUI PLT. If at least one debug session is enabled with the output set to *Console*, the GUI PLT opens a new console window showing the desired debug information.

Figure 80 shows an example of the *Debug Console*. Depending on the type of the message, a different color is used: *DEBUG* messages are light blue, *INFO* messages are white and *ERROR* messages are red.

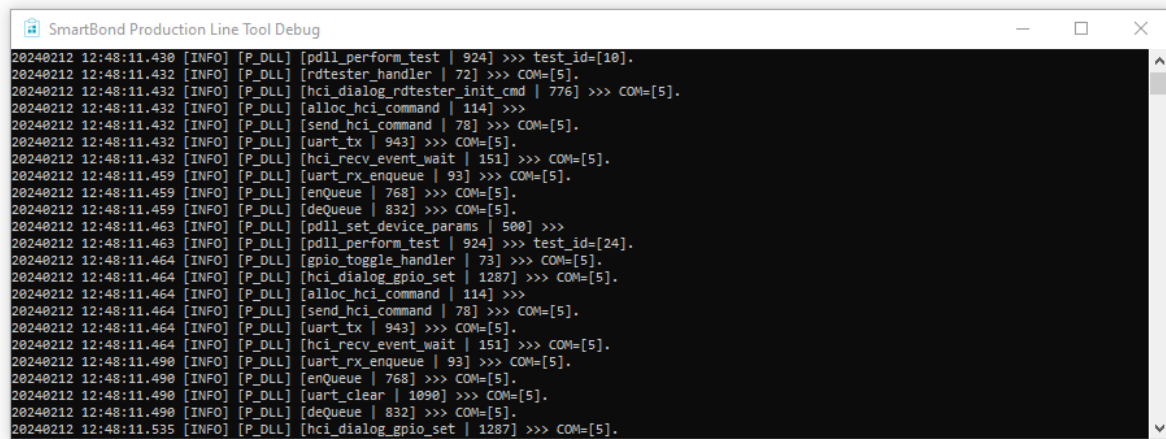

Figure 80. Debug console

SmartBond Production Line Tool

6.3.4 DUT log file

```

*Test_station_1_2024FEB08-094156_DUT_482335aad2a_1.log - Notepad
File Edit Format View Help
Software: SmartBond Production Line Tool
Software version: v_6.0
PLTD DLL version: v_6.0
PDLL Version: v_6.0
UDLL Version: v_6.0
Production test BLE firmware version: 11.0.1.0
Production test APP firmware version: 1.1
Flash programmer firmware version: 0.0.0.3
Date: 2024-02-08
Start Time: 09:41:56.823
End Time: 09:42:08.660
Station ID: Test_station_1
Device ID: 16
COM port: 21
DUT IC: DA14592
Tester ID: Tester_1
BD address: 48:23:35:aa:db:2a
Serial number: 1

|<time>|<action>|<pass/fail>|<info>
#####
|09:41:57.908|DUT_UDLL_FW_DOWNLOAD_INIT|STARTED|UDLL firmware download initialized. Firm
|09:41:57.929|DUT_UDLL_FW_DOWNLOAD_START|STARTED|UDLL firmware download started OK. Firm
|09:41:59.965|DUT_UDLL_FW_DOWNLOAD_OK|PASS|UDLL firmware downloaded OK. Firmware is
|09:41:59.970|DUT_UDLL_FW_DOWNLOAD_OK|PASS|UDLL firmware downloaded OK. Firmware is
|09:41:59.974|DUT_UDLL_FW_VER_GET_INIT|STARTED|UDLL 'firmware version get' operation in
|09:41:59.980|DUT_UDLL_FW_VER_GET_STARTED|STARTED|UDLL 'firmware version get' operation st
|09:42:00.025|DUT_UDLL_FW_VER_GET_OK|PASS|UDLL 'firmware version get' operation er
|09:42:00.028|DUT_UDLL_RAM_FW_DOWNLOAD_INIT|STARTED|Download binary to RAM operation initia
|09:42:00.032|DUT_UDLL_RAM_FW_DOWNLOAD_STARTED|STARTED|Download binary to RAM operation starte
|09:42:01.327|DUT_UDLL_RAM_FW_DOWNLOAD_OK|PASS|Download binary to RAM operation ended (
|09:42:01.450|DUT_PDLL_COM_PORT_INIT|STARTED|Device P_DLL COM port open initialized.
|09:42:01.454|DUT_PDLL_COM_PORT_START|STARTED|Device P_DLL COM port open started.
|09:42:01.475|DUT_PDLL_COM_PORT_OK|PASS|Device P_DLL COM port opened OK.
|09:42:01.541|DUT_PDLL_FW_VERSTON GET START|STARTED|Device P DLL Firmware version get starte

```

Figure 81. DUT log file

Figure 81 shows a Log file generated for DUT1 during testing.

In the first few lines of the log, a header is created giving vital information about the PLT hardware and the software. It includes the firmware and software version, the station name and test dates and times. It also holds information about the DUT, such as the connector number in the PLT hardware, the BD address assigned to it and the Windows COM port. For the DUTs that have failed, the log file is renamed with the word "_FAILED" at the end for easier retrieval.

The Log file is created at the beginning of each test, containing only the header and all information available at the time of creation. As the device testing progresses, the status of each test is written at the end of the log file, including information about the DUT and a timestamp of the event. After the tests finish the header is updated with the end time of the test and the firmware versions, which were retrieved during testing.

SmartBond Production Line Tool

6.3.5 CSV file

Start time	End time	Tester ID	DUT	BD address	Overall	COM port	FW downl	FW path 2	FW versio	FW versio	GPIO Wat	RAM FW d	RAM FW c	FW versio	FW versio	GPIO Wat	ADC	VBAT	VBAT leve
11:38:07	11:38:47	Tester_1	13	00:00:00:0	FAIL	101	PASS	C:\DiaSen	PASS	0.0.0.4	PASS	PASS	C:\DiaSen	PASS	1.1	PASS	PASS	PASS	3330
11:38:07	11:38:47	Tester_1	14	00:00:00:0	FAIL	102	PASS	C:\DiaSen	PASS	0.0.0.4	PASS	PASS	C:\DiaSen	PASS	1.1	PASS	PASS	PASS	3330
11:38:07	11:38:47	Tester_1	15	00:00:00:0	FAIL	103	PASS	C:\DiaSen	PASS	0.0.0.4	PASS	PASS	C:\DiaSen	PASS	1.1	PASS	PASS	PASS	3325.24
11:38:07	11:38:47	Tester_1	16	00:00:00:0	FAIL	104	PASS	C:\DiaSen	PASS	0.0.0.4	PASS	PASS	C:\DiaSen	PASS	1.1	PASS	PASS	PASS	3334.76
11:39:33	11:40:10	Tester_1	1	00:00:00:0	FAIL	89	PASS	C:\DiaSen	PASS	0.0.0.4	PASS	PASS	C:\DiaSen	PASS	1.1	PASS	PASS	PASS	3330
11:39:33	11:40:10	Tester_1	2	00:00:00:0	FAIL	90	PASS	C:\DiaSen	PASS	0.0.0.4	PASS	PASS	C:\DiaSen	PASS	1.1	PASS	PASS	PASS	3320.49
11:39:33	11:40:10	Tester_1	3	00:00:00:0	FAIL	91	PASS	C:\DiaSen	PASS	0.0.0.4	PASS	PASS	C:\DiaSen	PASS	1.1	PASS	PASS	PASS	3330
11:39:33	11:40:10	Tester_1	4	00:00:00:0	FAIL	92	PASS	C:\DiaSen	PASS	0.0.0.4	PASS	PASS	C:\DiaSen	PASS	1.1	PASS	PASS	PASS	3320.49
11:39:33	11:40:10	Tester_1	5	00:00:00:0	FAIL	93	PASS	C:\DiaSen	PASS	0.0.0.4	PASS	PASS	C:\DiaSen	PASS	1.1	PASS	PASS	PASS	3334.76
11:39:33	11:40:10	Tester_1	6	00:00:00:0	FAIL	94	PASS	C:\DiaSen	PASS	0.0.0.4	PASS	PASS	C:\DiaSen	PASS	1.1	PASS	PASS	PASS	3334.76
11:39:33	11:40:10	Tester_1	7	00:00:00:0	FAIL	95	PASS	C:\DiaSen	PASS	0.0.0.4	PASS	PASS	C:\DiaSen	PASS	1.1	PASS	PASS	PASS	3310.97
11:39:33	11:40:10	Tester_1	8	00:00:00:0	FAIL	96	PASS	C:\DiaSen	PASS	0.0.0.4	PASS	PASS	C:\DiaSen	PASS	1.1	PASS	PASS	PASS	3330
11:39:33	11:40:10	Tester_1	9	00:00:00:0	FAIL	97	PASS	C:\DiaSen	PASS	0.0.0.4	PASS	PASS	C:\DiaSen	PASS	1.1	PASS	PASS	PASS	3330
11:39:33	11:40:10	Tester_1	10	00:00:00:0	FAIL	98	PASS	C:\DiaSen	PASS	0.0.0.4	PASS	PASS	C:\DiaSen	PASS	1.1	PASS	PASS	PASS	3320.49
11:39:33	11:40:10	Tester_1	11	00:00:00:0	FAIL	99	PASS	C:\DiaSen	PASS	0.0.0.4	PASS	PASS	C:\DiaSen	PASS	1.1	PASS	PASS	PASS	3315.73
11:39:33	11:40:10	Tester_1	12	00:00:00:0	FAIL	100	PASS	C:\DiaSen	PASS	0.0.0.4	PASS	PASS	C:\DiaSen	PASS	1.1	PASS	PASS	PASS	3325.24
11:39:33	11:40:10	Tester_1	13	00:00:00:0	FAIL	101	PASS	C:\DiaSen	PASS	0.0.0.4	PASS	PASS	C:\DiaSen	PASS	1.1	PASS	PASS	PASS	3330
11:39:33	11:40:10	Tester_1	14	00:00:00:0	FAIL	102	PASS	C:\DiaSen	PASS	0.0.0.4	PASS	PASS	C:\DiaSen	PASS	1.1	PASS	PASS	PASS	3330
11:39:33	11:40:10	Tester_1	15	00:00:00:0	FAIL	103	PASS	C:\DiaSen	PASS	0.0.0.4	PASS	PASS	C:\DiaSen	PASS	1.1	PASS	PASS	PASS	3325.24
11:39:33	11:40:10	Tester_1	16	00:00:00:0	FAIL	104	PASS	C:\DiaSen	PASS	0.0.0.4	PASS	PASS	C:\DiaSen	PASS	1.1	PASS	PASS	PASS	3334.76
11:41:19	11:42:42	Tester_1	1	00:00:00:0	PASS	89	PASS	C:\DiaSen	PASS	0.0.0.4	PASS	PASS	C:\DiaSen	PASS	1.1	PASS	PASS	PASS	3330
11:41:19	11:42:42	Tester_1	2	00:00:00:0	PASS	90	PASS	C:\DiaSen	PASS	0.0.0.4	PASS	PASS	C:\DiaSen	PASS	1.1	PASS	PASS	PASS	3320.49
11:41:19	11:42:42	Tester_1	3	00:00:00:0	PASS	91	PASS	C:\DiaSen	PASS	0.0.0.4	PASS	PASS	C:\DiaSen	PASS	1.1	PASS	PASS	PASS	3330
11:41:19	11:42:42	Tester_1	4	00:00:00:0	PASS	92	PASS	C:\DiaSen	PASS	0.0.0.4	PASS	PASS	C:\DiaSen	PASS	1.1	PASS	PASS	PASS	3320.49
11:41:19	11:42:42	Tester_1	5	00:00:00:0	PASS	93	PASS	C:\DiaSen	PASS	0.0.0.4	PASS	PASS	C:\DiaSen	PASS	1.1	PASS	PASS	PASS	3339.51
11:41:19	11:42:42	Tester_1	6	00:00:00:0	PASS	94	PASS	C:\DiaSen	PASS	0.0.0.4	PASS	PASS	C:\DiaSen	PASS	1.1	PASS	PASS	PASS	3334.76
11:41:19	11:42:42	Tester_1	7	00:00:00:0	PASS	95	PASS	C:\DiaSen	PASS	0.0.0.4	PASS	PASS	C:\DiaSen	PASS	1.1	PASS	PASS	PASS	3315.73
11:41:19	11:42:42	Tester_1	8	00:00:00:0	PASS	96	PASS	C:\DiaSen	PASS	0.0.0.4	PASS	PASS	C:\DiaSen	PASS	1.1	PASS	PASS	PASS	3330
11:41:19	11:42:42	Tester_1	9	00:00:00:0	PASS	97	PASS	C:\DiaSen	PASS	0.0.0.4	PASS	PASS	C:\DiaSen	PASS	1.1	PASS	PASS	PASS	3325.24
11:41:19	11:42:42	Tester_1	10	00:00:00:0	PASS	98	PASS	C:\DiaSen	PASS	0.0.0.4	PASS	PASS	C:\DiaSen	PASS	1.1	PASS	PASS	PASS	3325.24

Figure 82. CSV file

Figure 82 shows an example of a generated CSV file. As with the DUT Log File (Section 6.3.4), the PLT software and hardware information are shown along with valuable DUT information. The CSV file keeps information about all the production tests of a single day. A new CSV file is created every day.

6.4 CLI PLT application

The CLI PLT (SmartBond_PLT_CLI.exe) is a Command Line Interface application with similar functionality and features as the PLT GUI. It performs the device testing and memory programming. At the same time, it allows you to monitor the test procedure in detail. It supports the same configuration file created from the CFG PLT and can run the same tests as the GUI PLT.

Figure 83 shows the initial window of the CLI PLT software. The CLI PLT can be executed from a command line prompt, passing arguments externally and initiating the tests immediately. This is useful for scripting/batch files as shown in Section 6.4.3.

Parameters are automatically loaded from the params/params.xml file when the CLI PLT starts. If there is a parameter error, a warning is shown. It is recommended to run the x command or start the CFG PLT before running the tests and check the configuration parameters. If a change is made to the params.xml configuration file while CLI is open, the file should be reloaded using the i command. If any CS area writing test is scheduled, a message informs you and prompts for continuing.

SmartBond Production Line Tool

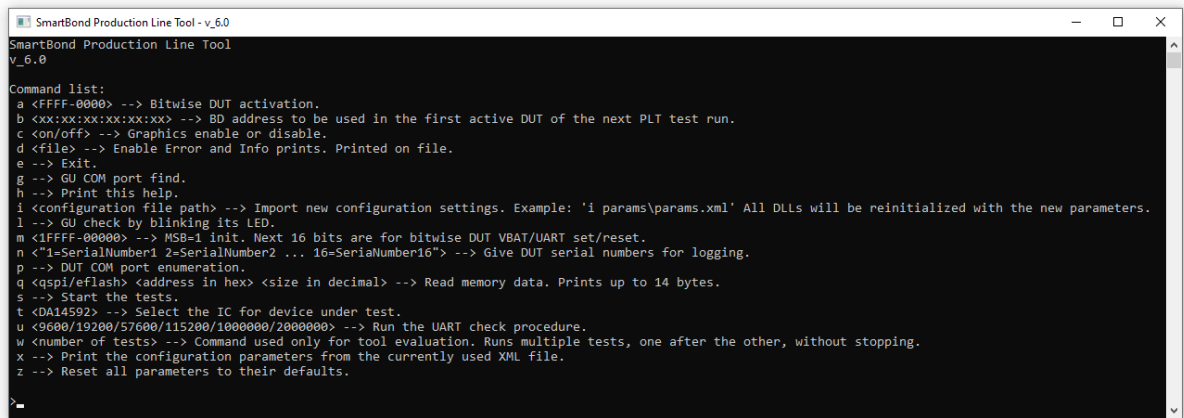

Figure 83. CLI software Start window

6.4.1 CLI commands

Table 60 lists all available CLI commands. A list with brief description of these commands can be printed using the `h` command.

Table 60. CLI commands

Cmd	Arguments	Description
a	Hex values from FFFF to 000.	Bitwise DUT activation. Sets the active DUTs to be tested. Examples: <ul style="list-style-type: none"> a 1: Only DUT 1 is activated and tested. a 9: DUTs 1 and DUT 4 is activated and tested.
b	xx:xx:xx:xx:xx:xx	Sets the start BD address of the first active DUT. Example: b FE:00:11:22:33:44
c	on/off	Enables or disables the graphics debug output of the CLI. Useful in the read BD address command <code>r</code> , to see only the DUT BD address returned and not the entire process. Example: c on
d	<ul style="list-style-type: none"> console file 	Use this option to enable error and info prints. Choose file output or console output. Only the <code>file</code> option is currently supported. Example: d file
e	none	Exits the application.
g	none	Execute the automatic GU Window COM port enumeration.
h	none	Help print out. Prints the list of the CLI commands that are available.
i	Path to XML configuration file.	Initializes the PLT with the parameters found in the <code>params.xml</code> file. Example: i params\params.xml.
l	none	Run the GU sanity check. The Golden Unit starts blinking its red LED.
m	First character:1 or 0. Then hex value from 1FFFF to 0000.	MSB character should be 1 the first time this command is executed. Consecutive <code>m</code> commands should have the MSB character set to 0. The next 16 bits are used for bitwise DUT VBAT/UART enable/disable. Example: m 1FFFF

SmartBond Production Line Tool

Cmd	Arguments	Description
n	1=SerialNumber1 2=SerialNumber2 16=SerialNumber16	You can provide a serial number for each DUT. The serial number is saved in the DUT log file and be added in the DUT log file name.
p	<i>none</i>	Execute the automatic DUT Window COM port enumeration.
q	First argument <ul style="list-style-type: none"> • eflash • qspi Second argument <ul style="list-style-type: none"> • The address in hex Third argument <ul style="list-style-type: none"> • The size in bytes 	This option can read from any memory, for any address offset up to 256 bytes of data.
s	<i>none</i>	Starts the tests.
t	<ul style="list-style-type: none"> • DA14592 	Selects the type of IC that the DUT uses. This option changes the DUT IC setting in the configuration file and reload all the settings Example: DA14592.
u	<ul style="list-style-type: none"> • 9600 • 19200 • 57600 • 115200 • 1000000 • 2000000 	This command performs a UART check connection for all the active DUTs for a specific baud rate.
w	Number of tests to run.	This command is used only for PLT evaluation. It starts with multiple tests. These are executed one after the other without your intervention.
x	<i>none</i>	Print the configuration parameters from the currently used XML file.
z	<i>none</i>	Resets all the XML parameters to their defaults.

6.4.2 Running the CLI and executing tests

There are several options to be called to make sure that the CLI PLT is set up correctly. Each of following commands is explained in [Table 60](#).

- Using the help command (`h`) the entire CLI command list is shown.

Example: `>h`

Set console options

- To redirect the debugging messages to the file use command `d`. This option is going to replace the UI debug values in the configuration file.

Example: `>d file`

SmartBond Production Line Tool

- To show or hide any prints in the Console window use command `c` with on/off argument.

Example: `>c on`

Check, reset, reload, and change settings

- Because the configuration file is automatically loaded, use the `x` command (Figure 84) to see the loaded settings. Errors is shown in red.

Example: `>x`

```

SmartBond Production Line Tool - v.6.0
[i= 170, k= 0] rf_path_loss_dut_16          3.69
[i= 171, k= 1] rssi_test_enable[1]        true
[i= 172, k= 2] rssi_test_enable[2]        false
[i= 173, k= 3] rssi_test_enable[3]        false
[i= 174, k= 1] rssi_test_name[1]          GU_RSSI_1
[i= 175, k= 2] rssi_test_name[2]          GU_RSSI_2
[i= 176, k= 3] rssi_test_name[3]          GU_RSSI_3
[i= 177, k= 1] rssi_freq[1]               2424
[i= 178, k= 2] rssi_freq[2]               2450
[i= 179, k= 3] rssi_freq[3]               2476
[i= 180, k= 1] per_limit[1]                10.0
[i= 181, k= 2] per_limit[2]                10.0
[i= 182, k= 3] per_limit[3]                10.0
[i= 183, k= 1] rssi_limit[1]               -70.0
[i= 184, k= 2] rssi_limit[2]               -70.0
[i= 185, k= 3] rssi_limit[3]               -70.0
[i= 186, k= 0] ble_tester_enable           false
[i= 187, k= 0] ble_tester_instr_name       mt8852b.dll
[i= 188, k= 0] ble_tester_instr_iface      GPIB0::27
[i= 189, k= 1] ble_test_tx_pwr_enable[1]   true
[i= 190, k= 1] ble_test_tx_pwr_name[1]     BLE_TX_PW
[i= 191, k= 1] ble_test_tx_pwr_freq[1]    2450
[i= 192, k= 1] ble_test_tx_pwr_range[1]    0
[i= 193, k= 1] ble_test_tx_pwr_tx_power[1] 0 dBm
[i= 194, k= 1] ble_test_tx_pwr_avg_high_limit[1] 10.00
[i= 195, k= 1] ble_test_tx_pwr_avg_low_limit[1] -20.00
[i= 196, k= 1] ble_test_tx_pwr_pk_avg_limit[1] 3.00
[i= 197, k= 1] ble_test_freq_offs_enable[1] false
[i= 198, k= 1] ble_test_freq_offs_name[1]   BLE_FREQ_OFS
[i= 199, k= 1] ble_test_freq_offs_freq[1]   2450
[i= 200, k= 1] ble_test_freq_offs_range[1]   0
[i= 201, k= 1] ble_test_freq_offs_tx_power[1] 0 dBm
[i= 202, k= 1] ble_test_freq_offs_pos_limit[1] 50
[i= 203, k= 1] ble_test_freq_offs_neg_limit[1] 50
[i= 204, k= 1] ble_test_freq_offs_drift_pkt_limit[1] 50
    
```

Figure 84. CLI PLT print settings (`x` command)

- To reset the configuration parameters to their defaults values the `z` command should be used.
- To reload the configuration file or to load another one, `i` command can be used.

Example: `>i params/params.xml`

- To change only the selected device IC, use the `t xxx` command, where `xxx` is the desired IC selection. If a change is made, all the settings are reloaded.

Example: `>t DA14592`

- To change the active DUTs use the `a` command. As an argument a 16-bit hexadecimal value is used, which is the bitwise representation of the active DUTs with DUT 1 being the LSB. This command replace the `dut_num_x` values in the configuration file.

The following example enables only DUT1, DUT2, DUT15 and DUT 16.

Example: `>a C003`

- To change the BD address that is used in the next run use the `b` command.

This option is going to replace the *BD address* and *Statistics* values in the configuration file.

Example: `>b 00:00:00:00:00:01`

SmartBond Production Line Tool

Hardware specific tests

- To automatically find the Windows COM port assigned to the Golden Unit, use the `g` command. This command replaces the `gu_com_port` value in the configuration file.
Example: `>g`
- To verify that the Golden Unit COM port is found correctly and to check if the Golden Unit is ready run the `l` command.
Example: `>l`
- To automatically find the Windows COM Port assigned for each DUT, use the `p` command. This command replaces the `com_port_dut_x` values in the configuration file.
Example: `>p`

DUT	BD ADDRESS	CODE	STATUS	RESULT
2	00:00:55:00:00:01	0	NOT ACTIVE	
3	00:00:55:00:00:02	2	COM PORT IDENTIFY STARTED	
4	00:00:55:00:00:03	3	COM PORT IDENTIFY OK	
GU	COM4	34	RD TESTER COM LOOPBACK OK	PASS OK

Figure 85. CLI PLT DUT COM port enumeration (`p` command)

- To run a UART error check use the `u` command followed with a specific Baud rate.
Example: `>u 1000000`

PLT production tests

- Use the `s` command to begin testing the current configuration. Figure 86 shows the CLI during the testing. After all the tests finished, the result remains on the screen as shown in Figure 87.

DUT	BD ADDRESS	CODE	STATUS	RESULT
2	00:00:55:00:00:01	9	FW DOWNLOAD STARTED	
3	00:00:55:00:00:02	9	FW DOWNLOAD STARTED	
4	00:00:55:00:00:03	9	FW DOWNLOAD STARTED	
GU	COM4	38	RD TESTER UBAT ENABLE OK	OK

BLE TESTER	TEMP	UOLT
NOT USED	NOT USED	NOT USED

Figure 86. CLI PLT testing

DUT	BD ADDRESS	CODE	STATUS	RESULT
2	00:00:55:00:00:01	216	SCAN TEST OK - DUT FOUND	PASS
3	00:00:55:00:00:02	216	SCAN TEST OK - DUT FOUND	PASS
4	00:00:55:00:00:03	216	SCAN TEST OK - DUT FOUND	PASS
GU	COM4	26	RD TESTER INIT OK	OK

BLE TESTER	TEMP	UOLT
NOT USED	NOT USED	NOT USED

DUT	QSPI BD ADDRESS	GIVEN BD ADDRESS	STATUS
02	00:00:55:00:00:01	00:00:55:00:00:01	MATCH
03	00:00:55:00:00:02	00:00:55:00:00:02	MATCH
04	00:00:55:00:00:03	00:00:55:00:00:03	MATCH

return status = 0xFFF1

Figure 87. CLI PLT testing finished

- Use the `q` command to read from any memory up to 256 bytes of data. The following example will read the first 10 bytes from the flash memory of the DUT.
Example: `>q qspi 0 10`

SmartBond Production Line Tool

Other test commands

- Use the `m` command to power on and access the DUTs to perform further testing. This opens the VBAT and the COM ports from the PLT hardware to the DUTs. As an argument, a `0` or `1` character is used to reset the PLT hardware. This is followed by a 16-bit hexadecimal number, which is the bitwise representation of the DUTs to use, with DUT 1 being the LSB.

In the following example, the PLT hardware is reset and DUTs 1, 2, 15, and 16 are used.

Example: `>m 1C003`

6.4.3 Using CLI commands with arguments

It is possible to start the CLI program with the commands described in Section 6.4.2 as arguments. This is useful for scripting/batch files.

```
C:\SmartBond_PLT_v_6.0\executables>SmartBond_PLT_CLI.exe -t DA14592 a 0001 -b 00:00:55:00:00:01 -s
SmartBond Production Line Tool
v_6.0
```

Figure 88. CLI with commands as arguments

The example shown in Figure 88 performs the commands described in Table 61.

Table 61: CLI example

Command	Description
<code>-t DA14592</code>	Set the DUT as DA14592.
<code>-a 0001</code>	Set the DUT1 as the only active DUT.
<code>-b 00:00:55:00:00:0</code>	Assign as the first BD address to be assigned the <code>00:00:55:00:00:01</code> . This BD address is used in DUT1, as it is the only active DUT.
<code>-s</code>	Perform the tests. BD address write in QSPI header should be enabled for the following test to pass.

6.5 GU Upgrade application

The GU Upgrade (`GU_fw_upgrade.exe`) is a Graphical User Interface application, which can be used to upgrade the firmware of the Golden Unit automatically, in contrast with that describes a manual way to upgrade the firmware of the Golden Unit. It guides you to configure, detect the PLT hardware and finally reprogram the SPI Flash memory onboard the PLT hardware with the Golden Unit firmware.

NOTE
to quickly access GU upgrade tool, under <code>Firmware Version - Golden Unit</code> , click the Upgrade GU firmware button, Section 6.2.2.5 in CFG PLT. Current version of the GU firmware can be seen using the Refresh button on the same section. This tool cannot upgrade PLT hardware version A.

6.5.1 Introduction window

The first page of the tool is an introduction window (Figure 89) showing the purpose of the tool. You can exit the tool at any step by clicking the **Cancel** button or close the application using the **X** button from the windows bar at the top.

SmartBond Production Line Tool

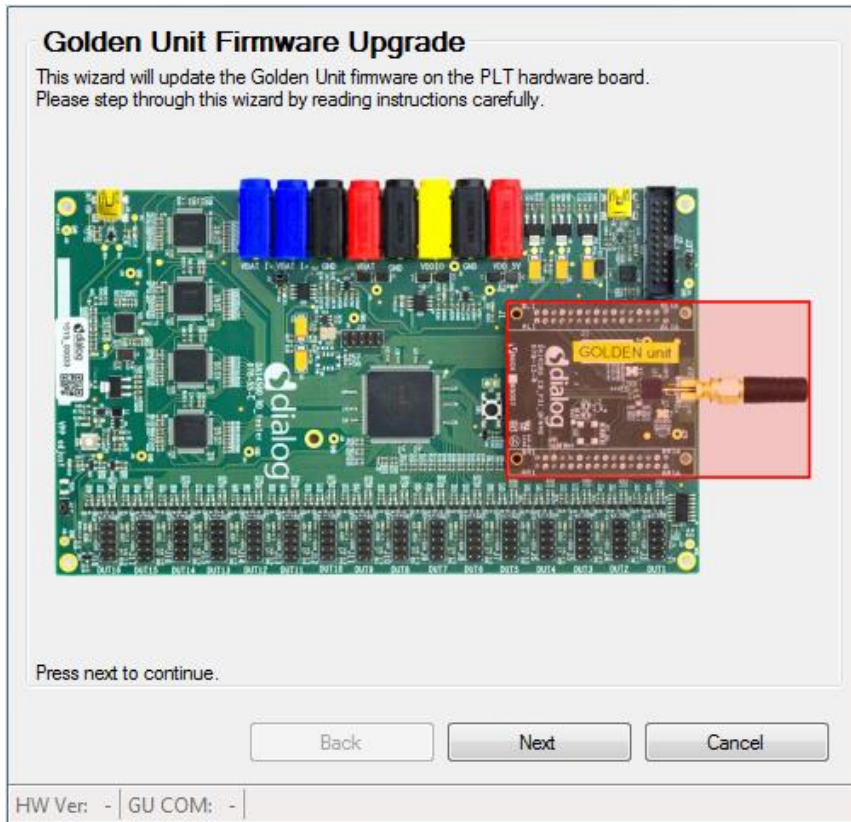

Figure 89. GU Upgrade - Introduction page

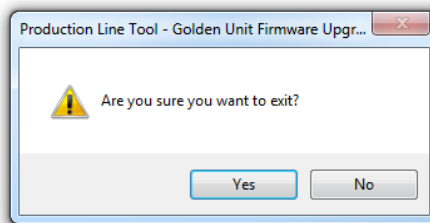

Figure 90. GU FW Upgrade - exit message

6.5.2 Hardware Version

In the **Hardware Version** dialog, you can select the PLT hardware version. Depending on the version, some options may be missing, or the tool may not support it. The selected hardware version is shown on the lower left of the tool at any of the following steps. As noted, the PLT hardware version A is not supported by this tool.

SmartBond Production Line Tool

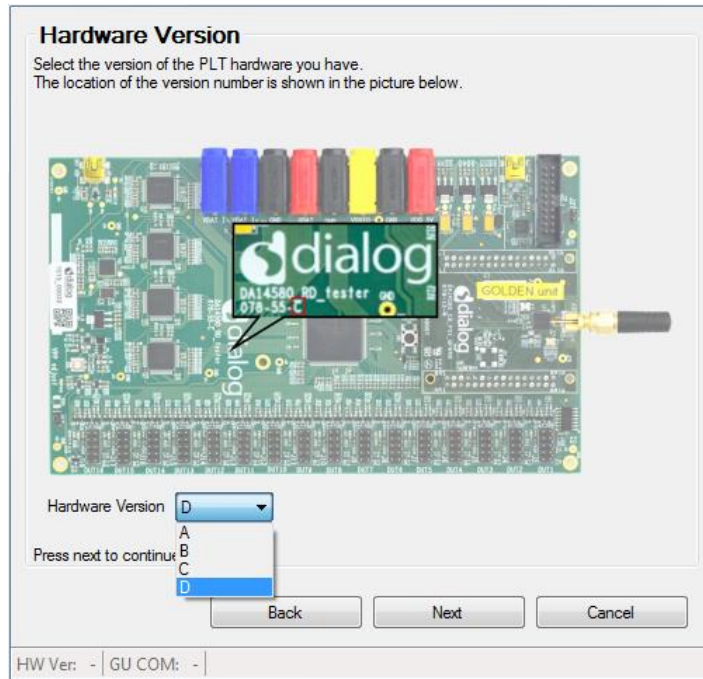

Figure 91. GU FW Upgrade - Hardware Version

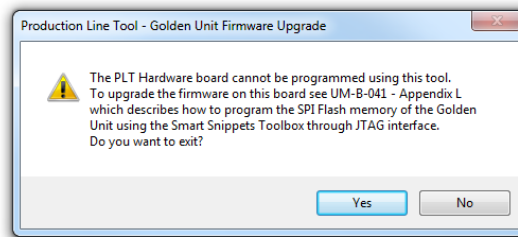

Figure 92. GU FW Upgrade - hardware version compatibility

6.5.3 Power Supply

Connect the power supply of the PLT, as described in Section 4.3 and connect the jumpers as shown in Figure 94 where applicable. Adjust the jumpers as proposed by the tool.

SmartBond Production Line Tool

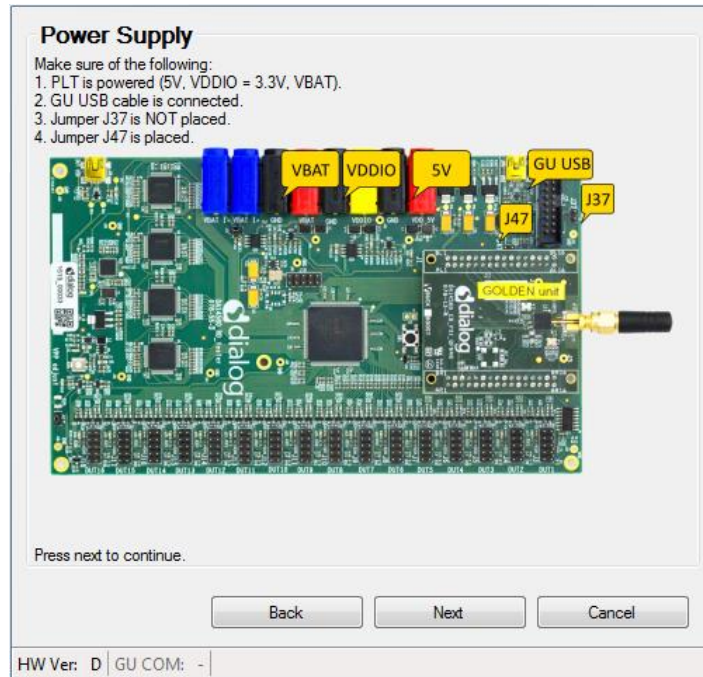

Figure 93. GU FW Upgrade - Power Supply

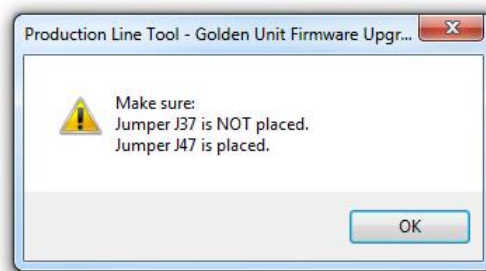

Figure 94. GU FW Upgrade - power supply pop-up

6.5.4 Golden Unit Reset

In **Golden Unit Reset** dialog, you can select the way to reset the GU. You can manually reset the GU, but PLT can do it automatically, which is the default selection. If the manual mode is selected, you are prompted any time the Golden Unit must be reset. To reset the Golden Unit, on the top of the PLT hardware next to the Golden Unit, click the **Reset** button.

SmartBond Production Line Tool

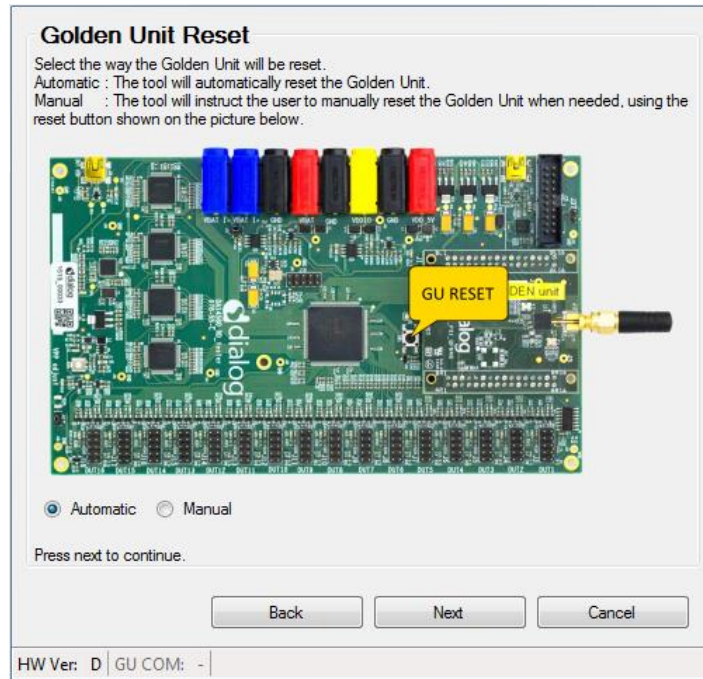

Figure 95. GU FW Upgrade - Golden Unit Reset

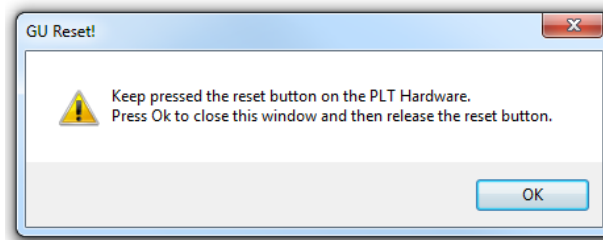

Figure 96. GU firmware Upgrade - Golden Unit reset message for Manual mode

6.5.5 GU COM Port

In the **GU COM Port** dialog, you can select the Windows assigned GU COM port. You can either select it from the dropdown list or use the **Auto** button to find it using the serial number as described in [Appendix H](#). GU COM port can also be verified using the **Check** button. Selected GU COM port is shown on the lower left of the tool.

SmartBond Production Line Tool

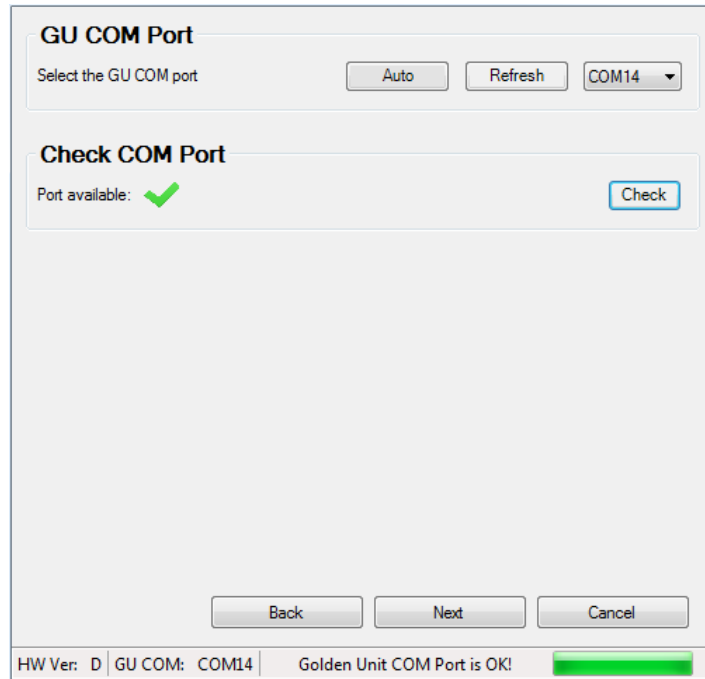

Figure 97. GU firmware Upgrade - GU COM Port

6.5.6 Burn Firmware

This is the final step. The binary to burn should be selected.

Clicking the **Burn** button erases the SPI Flash on the PLT hardware, programs it with the new firmware selected, and reads it back to verify that the contents written are the same as those in the binary.

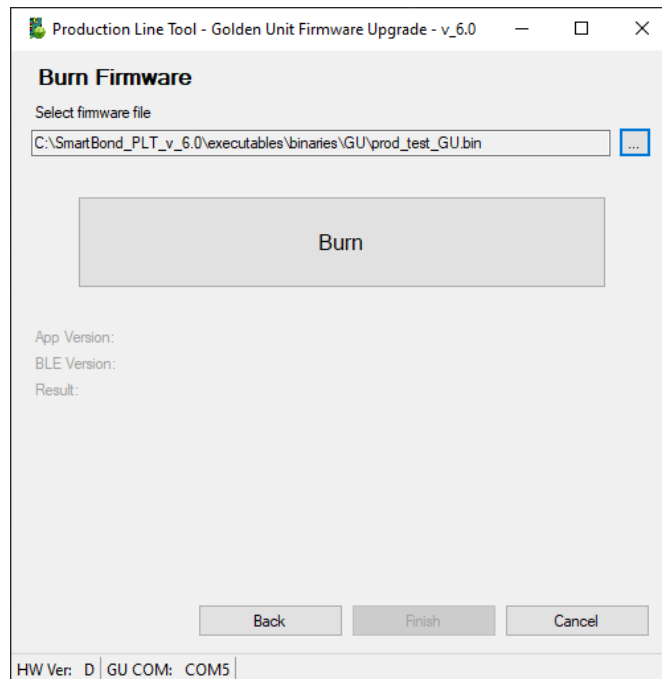

Figure 98. GU firmware Upgrade - burn firmware

SmartBond Production Line Tool

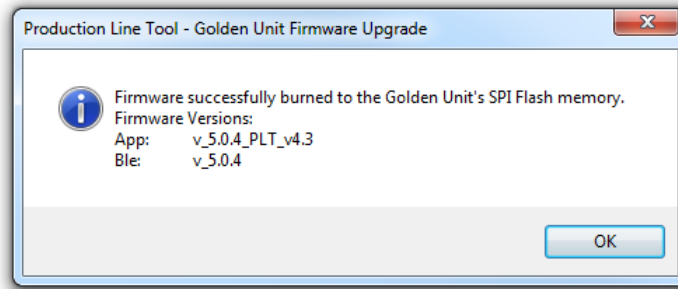

Figure 99. GU Upgrade - burn firmware pop-up message

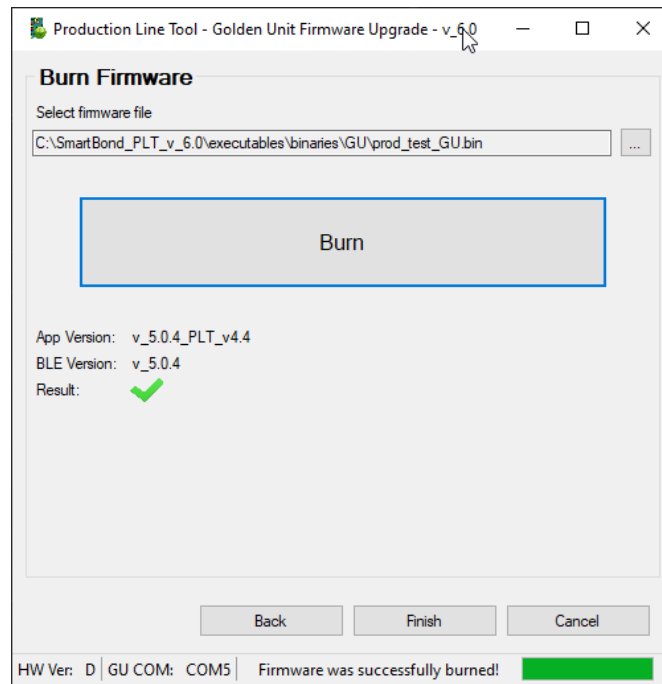

Figure 100. GU firmware Upgrade - burn firmware success

After the SPI flash program procedure is finished, a pop-up message appears with the result of the programming procedure. If the SPI flash was programmed successfully, the pop-up message also shows the version of the new Golden Unit firmware (Figure 99).

SmartBond Production Line Tool

7 Example Usage

In this section, a simple example of the PLT is described using one DA14592 device. The example test procedure is explained step-by-step in [Table 62](#).

The tests to run in this example are the XTAL trim, RF RSSI test, EFLASH programming. One DUT is used at PLT DUT connector position DUT1.

Table 62. PLT example usage

Step	Description								
Hardware connections									
1	Connect both DUTs to the PLT hardware as shown in Appendix K . Four cables are needed. To use the SPI Flash memory, a custom triple-jumper must be used.								
CFG GUI Settings									
2	Open CFG PLT and make the following selections.								
3	Hardware Setup								
		<table border="1"> <tr> <td>Device IC</td> <td>Select DA14591, and then click Save.</td> </tr> <tr> <td>Golden Unit COM Port</td> <td>Click Auto, and then click Save.</td> </tr> <tr> <td>Active DUTs</td> <td>Enable DUT1 only.</td> </tr> <tr> <td>DUT COM Ports</td> <td>Click Enum, and then click Save.</td> </tr> </table>	Device IC	Select DA14591, and then click Save .	Golden Unit COM Port	Click Auto , and then click Save .	Active DUTs	Enable DUT1 only.	DUT COM Ports
Device IC	Select DA14591, and then click Save .								
Golden Unit COM Port	Click Auto , and then click Save .								
Active DUTs	Enable DUT1 only.								
DUT COM Ports	Click Enum , and then click Save .								
4	VBAT/Reset Mode								
		<table border="1"> <tr> <td>Reset duration</td> <td>Set a time for the Reset to stay active.</td> </tr> <tr> <td>VBAT/Reset Mode</td> <td>Use VBAT On with Reset because it is faster to reset DUTs rather than performing a POR with the VBAT signal.</td> </tr> </table>	Reset duration	Set a time for the Reset to stay active.	VBAT/Reset Mode	Use VBAT On with Reset because it is faster to reset DUTs rather than performing a POR with the VBAT signal.			
Reset duration	Set a time for the Reset to stay active.								
VBAT/Reset Mode	Use VBAT On with Reset because it is faster to reset DUTs rather than performing a POR with the VBAT signal.								
5	General								
	Statistics	Click Reset , and then click Save .							

SmartBond Production Line Tool

Step	Description		
	<div style="border: 1px solid black; padding: 5px;"> <p>▲ Statistics</p> <p>Pass: 0 Fail: 0 Total: 0 Left: 0 Runs: 0</p> <p style="text-align: center;"><input type="button" value="Reset"/></p> <hr/> <p>▲ Test Options</p> <p><input checked="" type="checkbox"/> Production tests <input checked="" type="checkbox"/> Memory programming <input checked="" type="checkbox"/> Re-test failed DUTs</p> </div>	Test Options	<p>Enable all options, and then click Save.</p> <p>Production tests should be enabled for the XTAL Trim and the RF tests to run.</p> <p>Memory programming is required for the QSPI erase and check empty functions.</p> <p>Disable the rest of the options.</p>
6	DUT Hardware Setup		
	<div style="border: 1px solid black; padding: 5px;"> <p>▲ UART Baud Rate</p> <p>Baud Rate <input type="text" value="1000000"/></p> </div>	UART Baud Rate	1000000
7	Test Settings		
	<div style="border: 1px solid black; padding: 5px;"> <p>▲ XTAL Trim</p> <p><input checked="" type="checkbox"/> Enable GPIO input pulse pin <input type="text" value="UART Rx Pin"/></p> </div>	XTAL Trim	In XTAL Trim, select Enable . Select the same pin as the <i>UART Rx</i> .
	<div style="border: 1px solid black; padding: 5px;"> <p>RF RX test settings using the Golden Unit.</p> <p>GU_RSSI_1 (✓)</p> <p><input checked="" type="checkbox"/> Enable</p> <p>Test name <input type="text" value="GU_RSSI_1"/></p> <p>Settings</p> <p>Frequency <input type="text" value="2424"/> MHz</p> <p>Limits</p> <p>RSSI limit <input type="text" value=">= -70.0"/> dBm</p> </div>	RF Tests - Golden Unit	<p>Only one test is enabled for this example.</p> <p>In Golden Unit:</p> <ul style="list-style-type: none"> ● Select Enable ● Select 2424 MHz as frequency ● Set RSSI limit to -70 dBm ● Set Packet error limit to 10%.

SmartBond Production Line Tool

Step	Description
8	<p>Memory Functions</p> <div style="display: flex; justify-content: space-between;"> <div style="width: 30%;"> <p>Flash Write 1 (✓)</p> <p><input checked="" type="checkbox"/> Write enable</p> <p>Test name: <input type="text" value="EFLASH_WR"/></p> <p><input type="radio"/> QSPI <input checked="" type="radio"/> EFLASH</p> <p><input checked="" type="checkbox"/> Verify write</p> <p>Start address 0x <input type="text" value="00"/></p> <p>Image path: <input type="text" value="binaries\pxp_reporter_DA"/></p> </div> <div style="width: 30%;"> <p>Write 1 test</p> </div> <div style="width: 35%;"> <ul style="list-style-type: none"> • Select Write enable • Select EFLASH • Select Verify Write • Make sure <code>pxp_reporter_da1459x.img</code> is selected. </div> </div>

GUI PLT

10 Open GUI PLT

The screenshot shows the following details:

- Start BD address:** 48:23:35:AA:BB:01
- Next BD address:** 48:23:35:AA:DB:1B
- End BD address:** 00:00:00:00:00:00
- Statistics:** Pass: 17, Fail: 9, Total: 0, Left: 0, Runs: 29
- IC:** DA14592
- Checkboxes:** COM Enum, GU Check, VBAT/JART, UART check (all unchecked)
- DUT Table:**

DUT	BD Address	Code	Status	Result
1	48:23:35:AA:DB:1B			
- GU Table:**

GU	COM Port	Code	Status	Result
	COM5			
- Bottom Panel:** BLE Tester, Temp, Ammeter (all empty), and a large **START** button.
- Status Bar:** Retest failed: Disabled | Test Time: 00:00:00

SmartBond Production Line Tool

Step	Description
11	To begin testing, press Spacebar.
	<p>The following screenshot shows the UART channels for both DUTs for the entire PLT run. Top markers show the timings between each of the active tests.</p>
	<p>The log file following screenshot shows the test steps from the log file of DUT1 with the timing marks from the logic analyzer capture. These marks are described below. From the log file, the total time of each test can be calculated.</p> <pre> <time> <action> <pass/fail> <info> ##### 14:45:49.761 DUT_UDLL_FW_DOWNLOAD_INIT STARTED UDLL firmware download initialized. Firmwar 14:45:49.780 DUT_UDLL_FW_DOWNLOAD_START STARTED UDLL firmware download started OK. Firmware 14:45:55.356 DUT_UDLL_FW_DOWNLOAD_OK PASS UDLL firmware downloaded OK. Firmware is=(C 14:45:55.357 DUT_UDLL_FW_DOWNLOAD_OK PASS UDLL firmware downloaded OK. Firmware is=(C 14:45:55.358 DUT_UDLL_FW_VER_GET_INIT STARTED UDLL 'firmware version get' operation initi 14:45:55.359 DUT_UDLL_FW_VER_GET_STARTED STARTED UDLL 'firmware version get' operation start 14:45:55.400 DUT_UDLL_FW_VER_GET_OK PASS UDLL 'firmware version get' operation ended 14:45:55.401 DUT_UDLL_RAM_FW_DOWNLOAD_INIT STARTED Download binary to RAM operation initialize 14:45:55.403 DUT_UDLL_RAM_FW_DOWNLOAD_STARTED STARTED Download binary to RAM operation started. 14:46:01.016 DUT_UDLL_RAM_FW_DOWNLOAD_OK PASS Download binary to RAM operation ended OK. 14:46:01.144 DUT_PDLL_COM_PORT_INIT STARTED Device P_DLL COM port open initialized. 14:46:01.145 DUT_PDLL_COM_PORT_START STARTED Device P_DLL COM port open started. 14:46:01.164 DUT_PDLL_COM_PORT_OK PASS Device P_DLL COM port opened OK. 14:46:01.219 DUT_PDLL_FW_VERSION_GET_START STARTED Device P_DLL Firmware version get started. 14:46:01.310 DUT_PDLL_FW_VERSION_GET_OK PASS Device P_DLL Firmware version get OK. PDLL 14:46:01.311 DUT_PDLL_XTAL_TRIM_INIT STARTED XTAL trim operation initialized. GPIO selec 14:46:01.312 DUT_PDLL_XTAL_TRIM_START STARTED XTAL trim operation started. 14:46:04.410 DUT_PDLL_XTAL_TRIM_OK PASS XTAL trim operation ended OK. 14:46:04.459 DUT_PDLL_UART_RESYNC_INIT STARTED UART resynchronization process initialized. 14:46:04.461 DUT_PDLL_UART_RESYNC_START STARTED UART resynchronization process started. 14:46:04.716 DUT_PDLL_UART_RESYNC_OK PASS UART resynchronization process OK. 14:46:04.717 DUT_PDLL_XTAL_TRIM_READ_INIT STARTED XTAL trim value read initialized. 14:46:04.719 DUT_PDLL_XTAL_TRIM_READ_START STARTED XTAL trim value read started. 14:46:04.746 DUT_PDLL_XTAL_TRIM_READ_OK PASS XTAL trim value read OK. Value is=[0x00325 14:46:04.747 DUT_PDLL_PKT_RX_STATS_START_INIT STARTED RF RX packet test with statistics start ini 14:46:04.749 DUT_PDLL_PKT_RX_STATS_START STARTED RF RX packet test with statistics start. 14:46:04.762 DUT_PDLL_PKT_RX_STATS_STARTED_OK PASS RF RX packet test with statistics started O 14:46:05.079 DUT_PDLL_PKT_RX_STATS_STOP_INIT STARTED RF RX packet test with statistics stop init 14:46:05.081 DUT_PDLL_PKT_RX_STATS_STOP_START STARTED RF RX packet test with statistics stop. 14:46:05.140 DUT_PDLL_PKT_RX_STATS_STOPPED_OK PASS RF RX packet test with statistics stopped O 14:46:05.141 DUT_PDLL_GU_RF_RX_TEST_PASSED PASS Golden Unit RF RX test PASSED. RF RX 14:46:05.626 DUT_UDLL_FW_DOWNLOAD_INIT STARTED UDLL firmware download initialized. Firmwar 14:46:05.638 DUT_UDLL_FW_DOWNLOAD_START STARTED UDLL firmware download started OK. Firmware 14:46:11.205 DUT_UDLL_FW_DOWNLOAD_OK PASS UDLL firmware downloaded OK. Firmware is=(C 14:46:11.206 DUT_UDLL_FW_DOWNLOAD_OK PASS UDLL firmware downloaded OK. Firmware is=(C 14:46:11.207 DUT_UDLL_FW_VER_GET_INIT STARTED UDLL 'firmware version get' operation initi 14:46:11.208 DUT_UDLL_FW_VER_GET_STARTED STARTED UDLL 'firmware version get' operation start 14:46:11.257 DUT_UDLL_FW_VER_GET_OK PASS UDLL 'firmware version get' operation ended 14:46:11.258 DUT_UDLL_FLASH_INIT_INIT STARTED Flash initialization operation initialized. 14:46:11.259 DUT_UDLL_FLASH_INIT_STARTED STARTED Flash initialization operation started. 14:46:11.305 DUT_UDLL_FLASH_INIT_OK PASS Flash initialization operation ended OK. F1 14:46:11.306 DUT_UDLL_FLASH_IMG_WR_INIT STARTED Flash image write operation initialized. F1 14:46:11.308 DUT_UDLL_FLASH_IMG_WR_STARTED STARTED Flash image write operation started. Flash 14:46:27.196 DUT_UDLL_FLASH_IMG_WR_OK PASS Flash image write operation ended OK. Flash </pre>
T0-T1	The UART boot firmware download (uartboot_da1459x_minimal.bin) begins. From the log file, the test lasted for about 5.6 seconds, which can be verified from the logic analyzer capture. This is followed by the operation to get the version of the uartboot_da1459x.bin firmware.
T1-T2	This time includes getting the version of the uartboot_da1459x_minimal.bin firmware, downloading st_fw_da1459x.bin in RAM and getting the version of the st_fw_da1459x.bin. This time is about 6 seconds.
T2-T3	This time includes the production tests. The XTAL trim and the GU RF RSSI test. Time is about 4.3 seconds.

SmartBond Production Line Tool

Step	Description																																							
T3-T4	This time is for downloading <code>uartboot_da1459x.bin</code> to be used for memory programming. Time is about 5.6 seconds.																																							
T4-T5	This is the time for QSPI Flash memory programming of <code>pxp_reporter_da1459x.img</code> (310 KB) with readback verify operation. Total time is about 16 seconds. Time can be reduced significantly if readback verification is disabled.																																							
	<p>The PLT run finished.</p>																																							
	<p>After the tests finish, the log and CSV files are fully updated. The GUI PLT test counter on the lower right of the dialog indicates that the test took approximately 40 seconds. This is verified from both the DUT log file and the CSV log file. Both files are shown below.</p> <pre> Software: SmartBond Production Line Tool Software version: v_6.0 PLTD DLL version: v_6.0 PDLL Version: v_6.0 UDLL Version: v_6.0 Production test BLE firmware version: Production test APP firmware version: Flash programmer firmware version: 0.0.0.3 Date: 2024-02-12 Start Time: 13:16:23.740 End Time: 13:16:56.638 Station ID: Test_station_1 Device ID: 15 COM port: 43 DUT IC: DA14592 Tester ID: Tester_1 BD address: 48:23:35:aa:db:1f Serial number: 45 </pre> <table border="1"> <thead> <tr> <th></th> <th>A</th> <th>B</th> <th>C</th> <th>D</th> <th>E</th> <th>F</th> <th>G</th> <th>H</th> <th>I</th> <th>J</th> <th>K</th> <th>L</th> </tr> </thead> <tbody> <tr> <td>1</td> <td>Start time</td> <td>End time</td> <td>Tester ID</td> <td>DUT</td> <td>BD address</td> <td>Overall st</td> <td>COM port</td> <td>Programn</td> <td>Programn</td> <td>Programn</td> <td>Programn</td> <td>Flash init</td> </tr> <tr> <td>2</td> <td>13:16:23</td> <td>13:16:56</td> <td>Tester_1</td> <td>15</td> <td>48:23:35:A</td> <td>PASS</td> <td>43</td> <td>PASS</td> <td>C:\SmartE</td> <td>PASS</td> <td>0.0.0.3</td> <td>PASS</td> </tr> </tbody> </table>		A	B	C	D	E	F	G	H	I	J	K	L	1	Start time	End time	Tester ID	DUT	BD address	Overall st	COM port	Programn	Programn	Programn	Programn	Flash init	2	13:16:23	13:16:56	Tester_1	15	48:23:35:A	PASS	43	PASS	C:\SmartE	PASS	0.0.0.3	PASS
	A	B	C	D	E	F	G	H	I	J	K	L																												
1	Start time	End time	Tester ID	DUT	BD address	Overall st	COM port	Programn	Programn	Programn	Programn	Flash init																												
2	13:16:23	13:16:56	Tester_1	15	48:23:35:A	PASS	43	PASS	C:\SmartE	PASS	0.0.0.3	PASS																												

Appendix A Top View of PLT PCB Version D

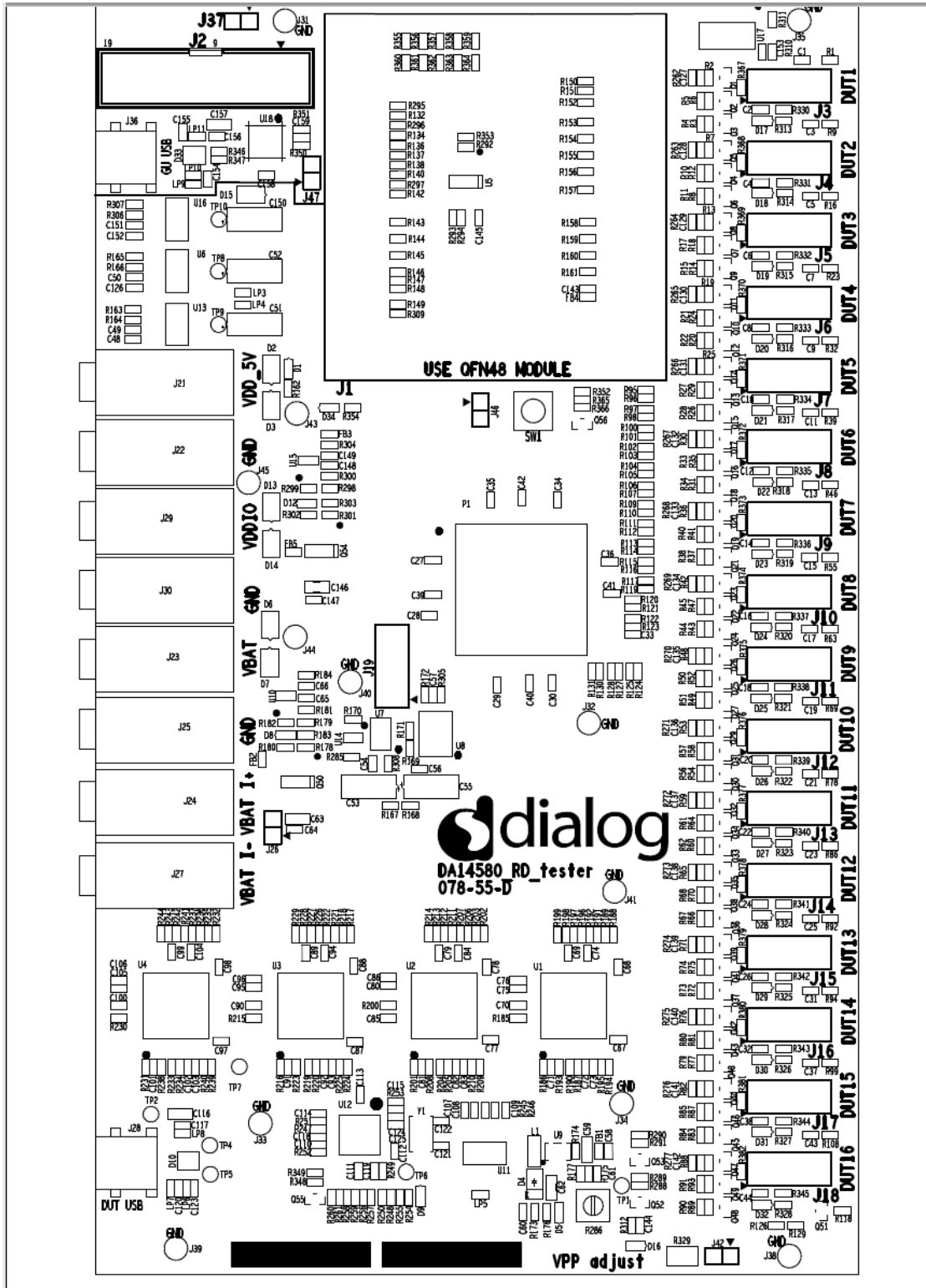

Figure 101. Top view of PLT PCB version D

Appendix B Electrical Schematics

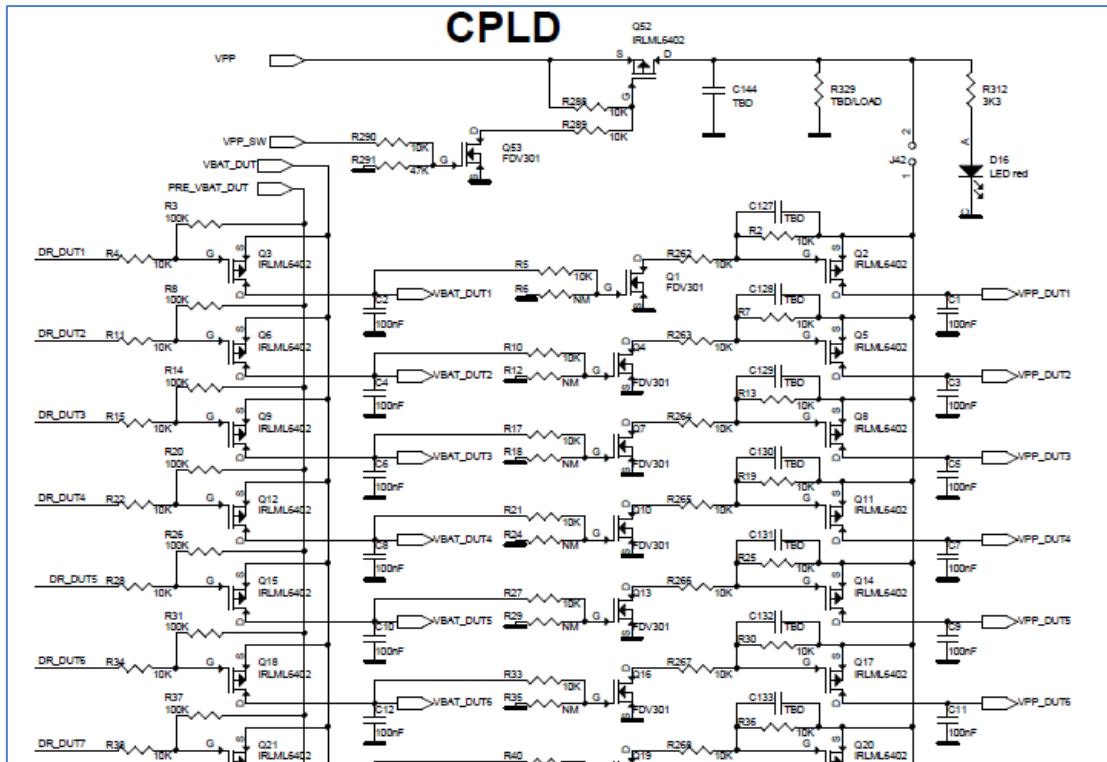

Figure 102. VBAT and VPP control from CPLD

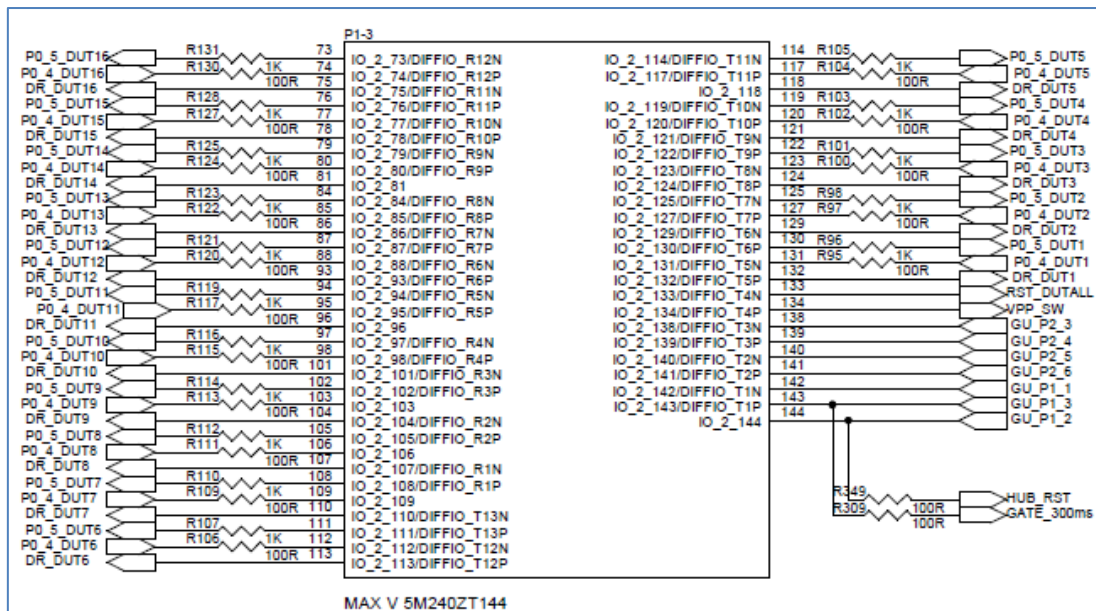

Figure 103. CPLD DUT UART connections

SmartBond Production Line Tool

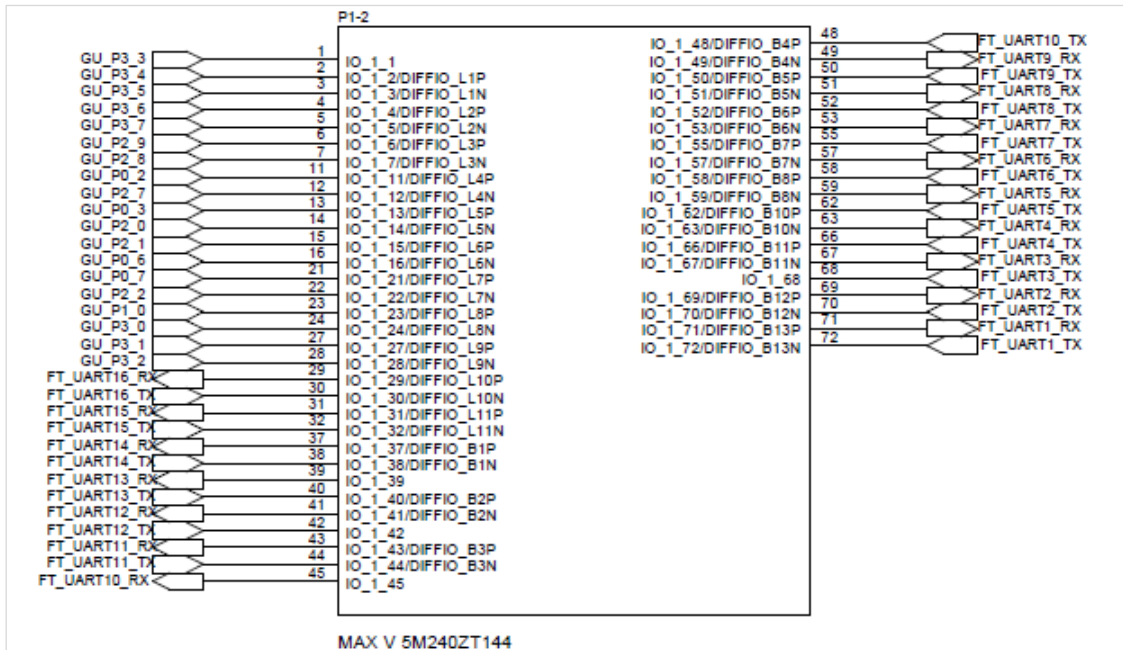

Figure 104. CPLD FTDI and GU control connections

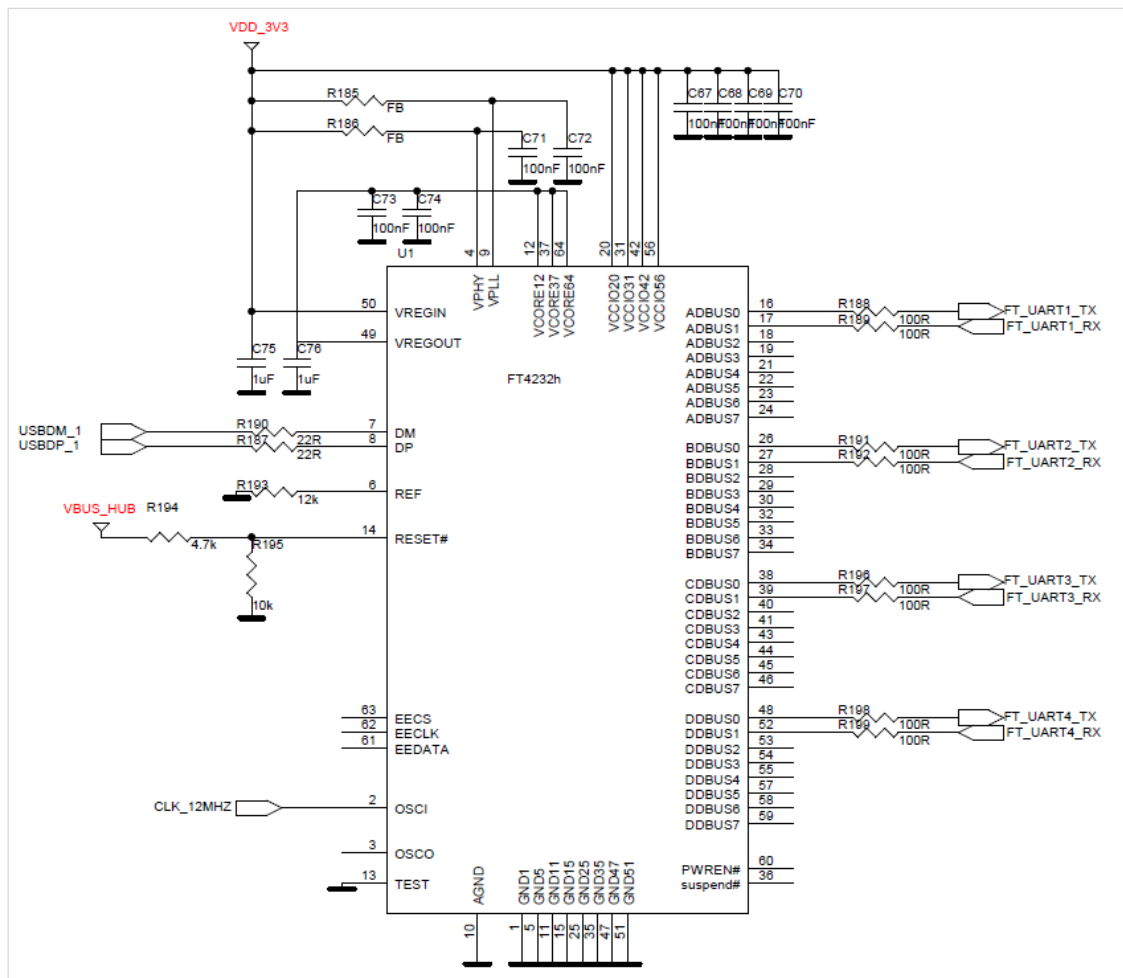

Figure 105. FTDI chip for USB UART to DUTs 1, 2, 3, and 4

SmartBond Production Line Tool

The USB HUB provides 5 V input for the 3.3 V LDO and USB input-signals to the four Quad FTDI chips.

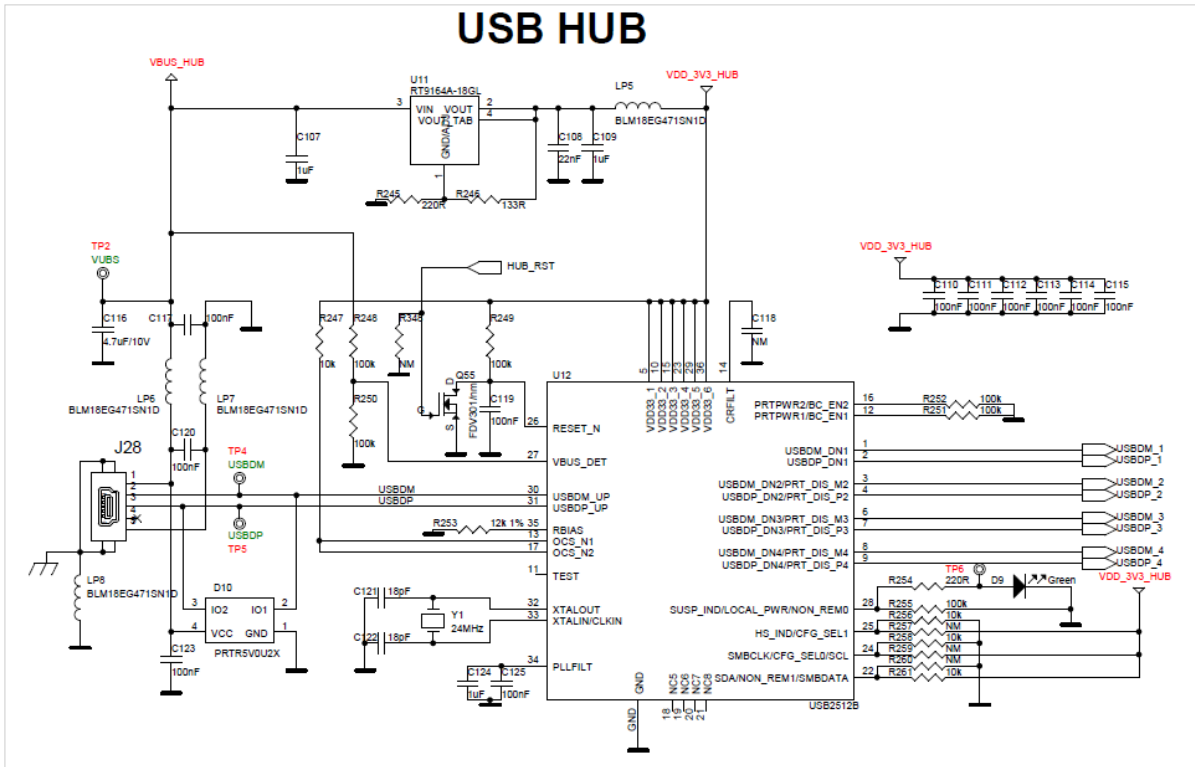

Figure 106. Quad USB HUB

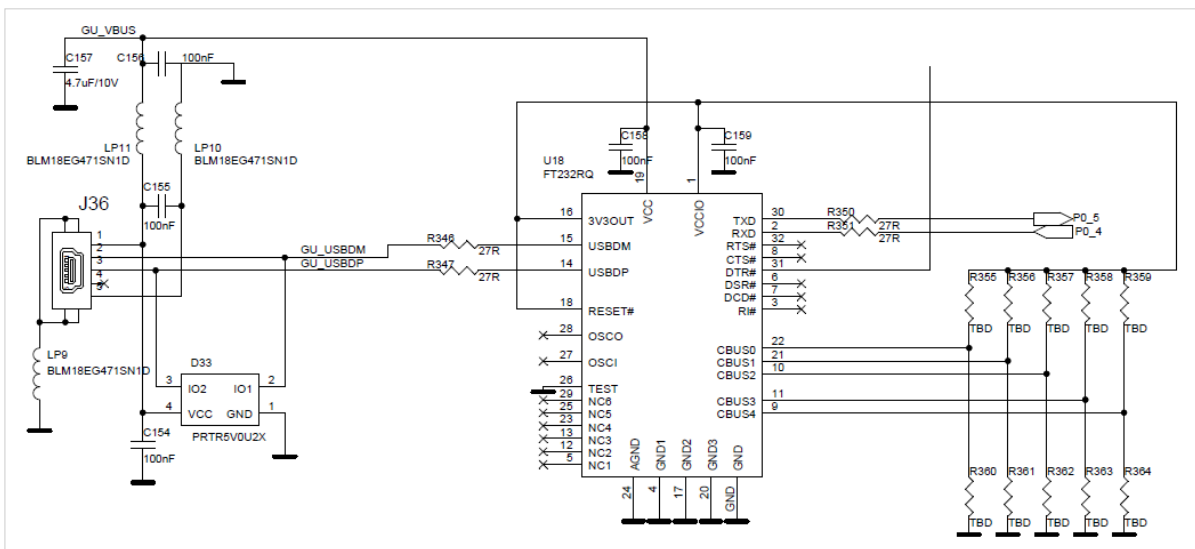

Figure 107. Golden Unit - dedicated USB port and FTDI chip

SmartBond Production Line Tool

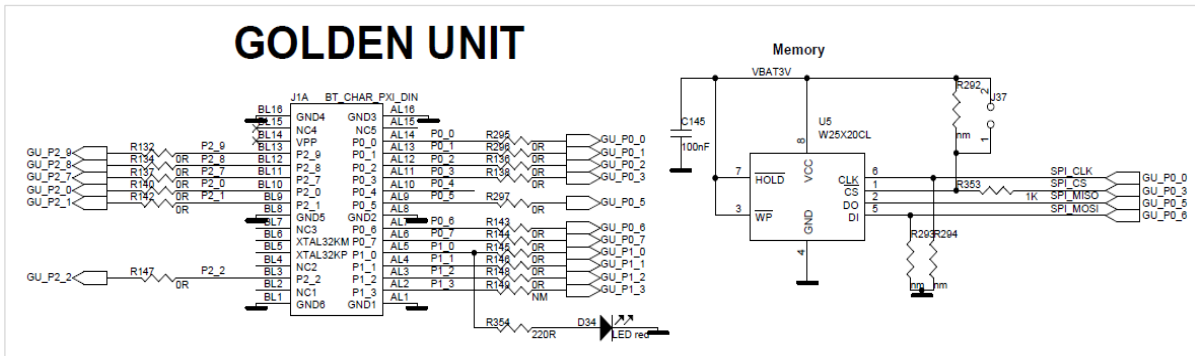

Figure 108. Golden Unit - GU LED and SPI Flash memory

The Golden Unit software (prod_test_GU.bin) is programmed into the SPI Flash memory mounted on the PLT hardware and is loaded into the GU's system RAM when powered on.

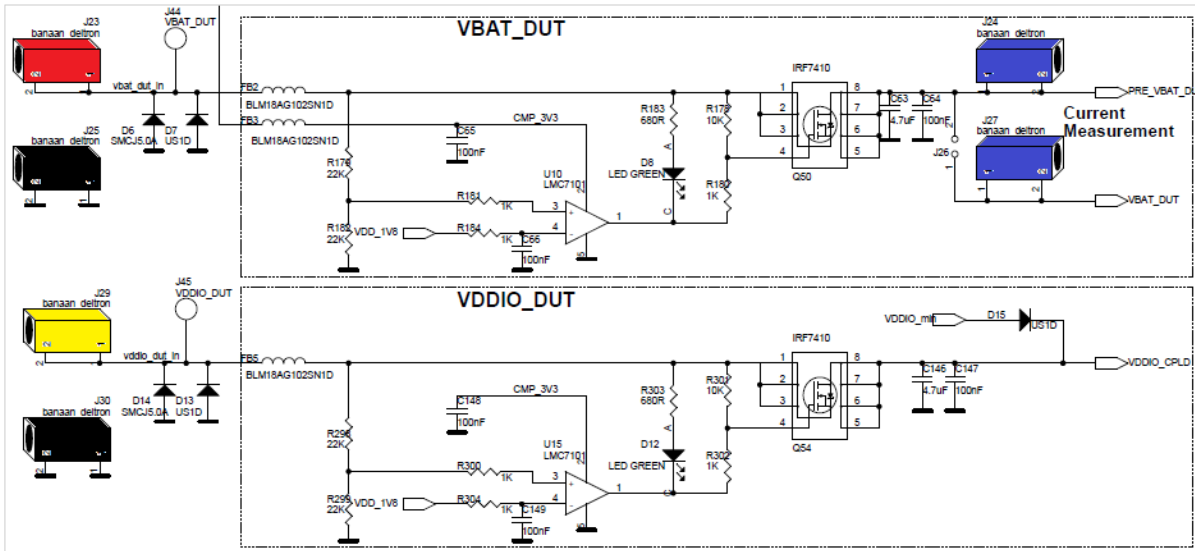

Figure 109. VBAT_DUT and VDDIO supplies

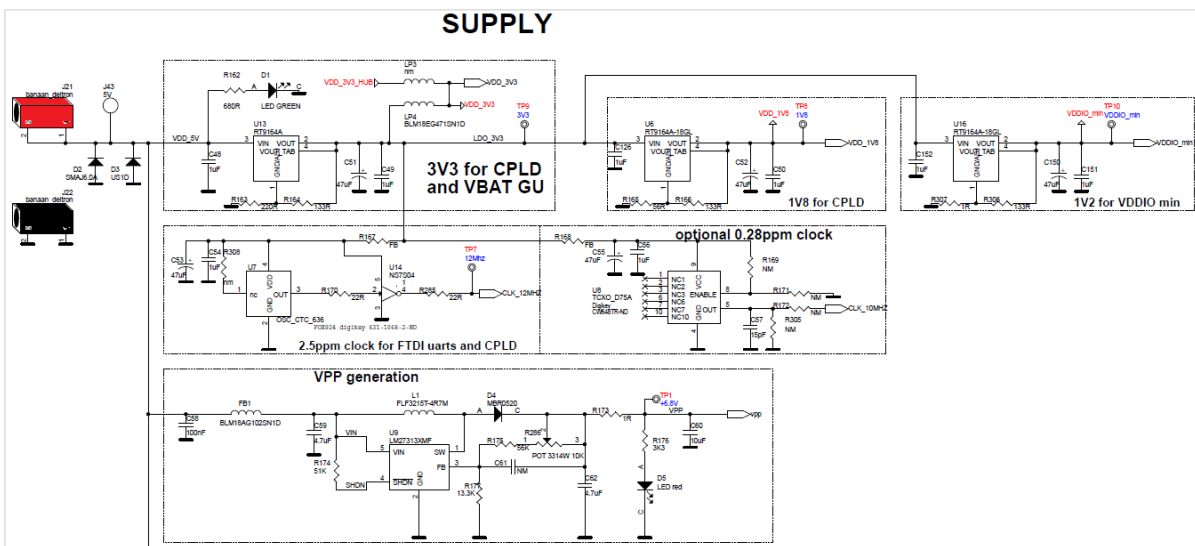

Figure 110. GU supply and VPP generation

SmartBond Production Line Tool

Appendix C Hardware Modifications PLT Version D

In the PLT hardware version D, there is a small modification. Resistor R365 (10 k Ω) and jumper J47 are added in series to the GU reset circuit.



Figure 111. DA14580_RD_tester version D

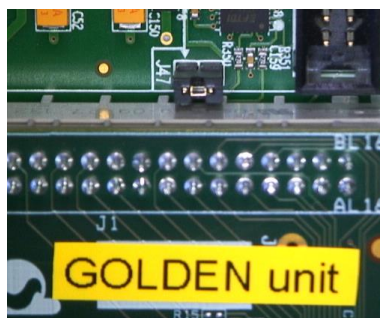

Figure 112. Jumper J47 added next to Golden Unit socket



Figure 113. R365 (10 k Ω) added next to Reset button

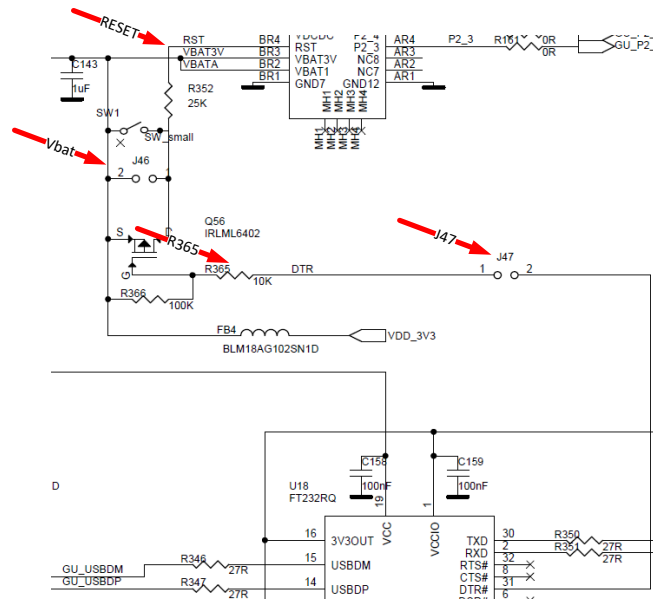

Figure 114. R365, J47 and RESET shown in electrical schematic

SmartBond Production Line Tool

Appendix D Application Hardware Design Considerations

When the Production Line Tool (PLT) is used, one should be aware of the following items:

- One could consider adding additional pads to the design for future debugging, not related to PLT, like pins for SWD.
- Pads are, in most cases, placed on the rear side of the circuit board. They should be gold plated. Dimensions of these pads are crucial and have to do with the stability and accuracy of the pogo-pins that connect to the PLT hardware. They should not be designed too critical. Long pogo pins might bend during production testing.
- Optionally, holes can be added for guiding-pins that fit on the test jig used for the PCB or panel.
- Orientation of the antenna used on the application board impacts the RSSI-value. When panels are used, this RSSI varies, dependent on the distance to the GU antenna on the PLT. In the PLT software an RSSI-offset can be added for each DUT location to compensate for these differences

More reference documentation is available on Renesas website: DA14592 Product page
https://www.renesas.com/us/en/products/wireless-connectivity/bluetooth-low-energy/da14592-smartbond-multi-core-bluetooth-le-52-soc-embedded-flash#design_development

Appendix E Suggestions about Hardware and Cabling

When connecting the PLT to the DUTs, special care should be taken regarding cabling.

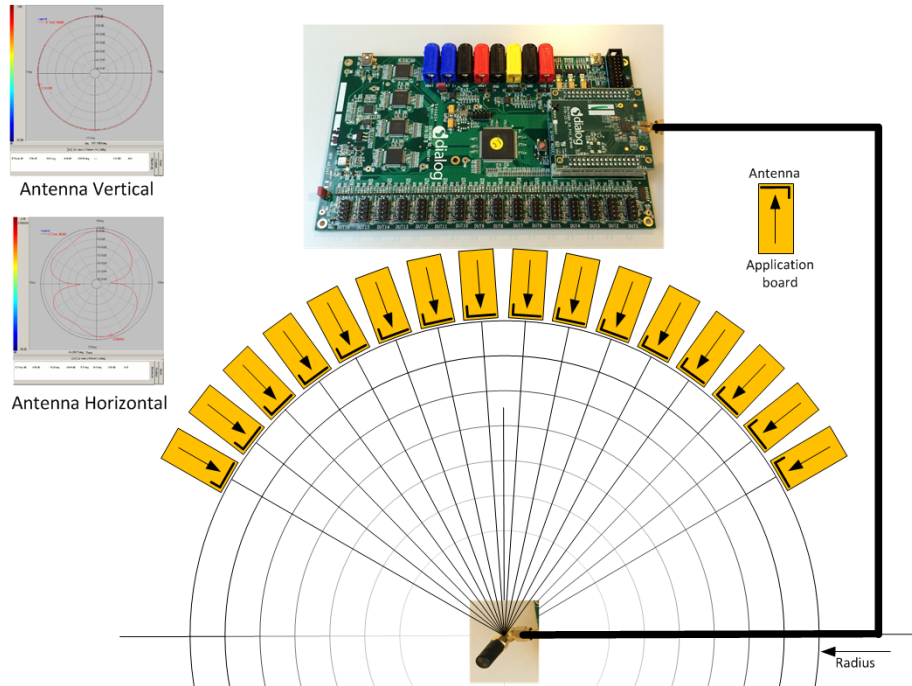

Figure 115. Possible solution of antenna on cable and fixed radius of DUTs to antenna

You should realize that the PLT system is equipped with RF transmitters and receivers. These parts may induce noise on hardware and cables. Take note of the following:

- The direction of the GU antenna to the DUT antenna influences the RSSI value
- The distance of the DUT antenna to the GU antenna (radius) influences the RSSI value
- The control lines from the PLT to the DUTs must be kept as short as possible
- A vertical GU antenna has different characteristics from a horizontal one, see [Figure 115](#).

SmartBond Production Line Tool

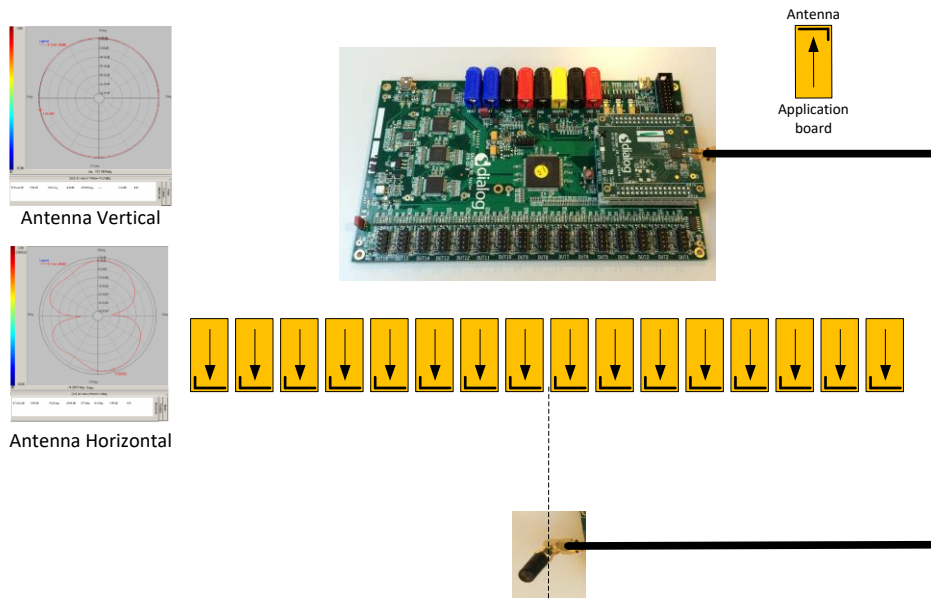

Figure 116. Possible solution of antenna on cable and DUTs put in line

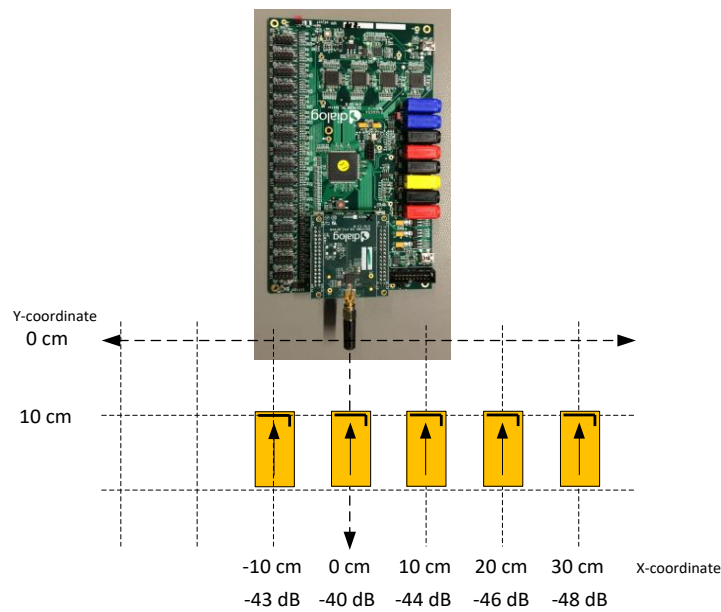

Figure 117. Example locations and RSSI readouts of horizontal antenna

Figure 117 shows the measured values from Table 63.

Table 63. RF Test RSSI results

Test	Distance (cm)	Offset (cm)	RSSI (dBm)	Description
1	10	0	-40	DUT and GU boards are inline.
2	10	-10	-43	DUT moved 10 cm to the left relative to the GU.
3	10	10	-44	DUT moved 10 cm to the right relative to the GU.
4	10	20	-46	DUT moved 20 cm to the right relative to the GU.

SmartBond Production Line Tool

Test	Distance (cm)	Offset (cm)	RSSI (dBm)	Description
5	10	30	-48	DUT moved 30 cm to the right relative to the GU.
6	10	normal	-40	DUT and GU boards are inline, functioning normally.
7	10	defect 1	-60 ~ -70	Coupling capacitor not soldered well, missing, or damaged.
8	10	defect 2	~ -60	Short-circuited shunt matching inductor (for example, solder bridge)
9	10	defect 3	< -100	32 MHz crystal oscillator not working well. Received packets ~ 0.
Golden Unit output power = 0 dBm				

For more details on the RF setup, see Ref. [\[1\]](#) and [Appendix F](#).

Appendix F RF Path Losses Calibration

To accurately perform radiated tests for 16 DUTs using the Golden Unit or a Bluetooth® LE tester, you should calibrate the setup to know what RSSI value can be expected for non-problematic devices. Because the distance and the position of each of the 16 DUTs to the GU RF antenna are different, the calibration process calculates the different path losses to compensate for these differences. The calculated values are applied to the Production Line Tool configuration as RF path losses (DA1459x - Path Losses per DUT [Figure 55](#)), which are added in the RSSI result.

This section describes the process to calculate the RF path losses for each different DUT position.

F.1 Prerequisites

[Table 64](#) shows the prerequisites needed for performing the RF path loss calibration procedure.

Table 64. Prerequisites

#	Requirements	Description
1	1 PLT board	1 PLT board with Golden Unit. Power supply for the PLT. USB cables for the PLT to the PC.
2	<10 PCBA with 16 DUTs each	At least 10 PCBAs. The more PCBAs used the better. The PCBAs selected should all work as good as possible. If a fault device is identified on a PCBA that PCBA should be replaced.
3	1 shielded box	It must be big enough to fit the PCBA and the fixture. It should have one SMA female to female connector and a small hole to pass the DUT to PLT cable connections.
4	2 RF cables (1 optional)	One cable to be used from the PLT GU to the shielded box. One more cable to be used from the shielded box to the RF antenna. (This is optional since the RF antenna can be directly mounted into the shielded box RF SMA connector). The cables should have low attenuation at 2.5 GHz range (<2 dB) and high shielding effectiveness (>60 dB). Proposed cables are from Radiall. Cables datasheet: https://www.radiall.com/media/files/RFCableAssemblies%20D1C004XEe.pdf <ul style="list-style-type: none"> ● Flexible cable 2.6/50 D (RD316) P/N: C291 185 067 ● Flexible cable 2/50 D (124416 type) P/N: C291 146 087 ● Flexible cable 2.6/50 D (ECO316D: alternative to RD316) P/N: C291 999 905 ● Flexible cable 5/50 D (ECO142: alternative to RG142) P/N: C291 325 290 ● Flexible cable 5/50 D (Power 142: alternative to RG142) P/N: C291 325 270 ● Flexible cable 6/50 D (ECO230) P/N: C291 326 490.
5	DUT fixture	A fixture to be placed inside the shielded box to easily connect the PCBAs to the PLT.

F.2 Setup

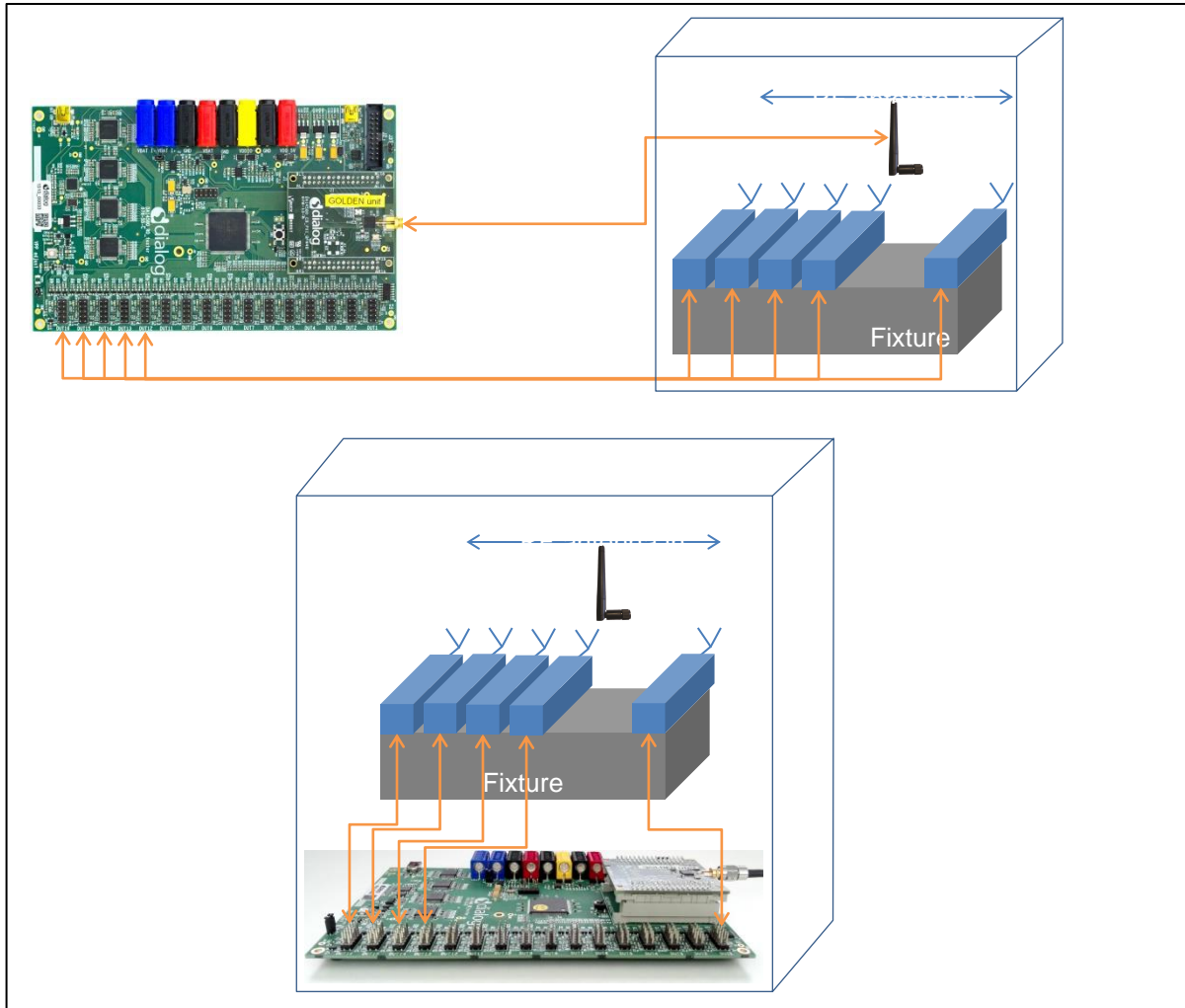

Figure 118. Setup diagram

Table 65. RF path losses calibration setup

Item	Description
PLT board	The PLT board could either be outside or inside the shielded box, as shown in Figure 118 , depending on the fixture setup.
DUTs	The DUT antennas should point the RF antenna.
PLT to DUT connections	The PLT to DUT cable connections should be as short as possible. Also, the cables should not block the RF path from DUT to the RF antenna.
Shielded box	The shielded box must be big enough to fit the PCBA and the fixture and the PLT if it is inside.
RF cable - PLT to shielded box.	<p>This type of cable must have good shielding and low attenuation. Effective shielding must be >60 dB. Check Table 64 for the best proposals.</p> <p>If multiple production lines are used, RF cable shielding is important to avoid disturbance from other close by PLTs. However, if other PLTs are far away (>3 m) other cables can be used.</p> <ul style="list-style-type: none"> FLEXIBLE CABLE 2.6/50 S (RG316 - KX22A) P/N: C291 170 007

SmartBond Production Line Tool

Item	Description
RF cable – Shielded box to RF antenna (optional).	<p>Due to the close distance between the DUT antennas and the RF antenna cable, cable shielding must be good, at least 60 dB. Check Table 64 for proposals.</p> <p>This cable can be optional. The RF antenna may be mounted directly onto the SMA RF connector inside the shielded box. In that case, the fixture and the DUTs should be placed appropriately (less than 20 cm).</p>
RF antenna	<p>The RF antenna can be any good Wi-Fi antenna that operates at 2.5 GHz. It should be placed in a vertical position as shown in Figure 118. The distance to the DUTs should not be larger than 20 cm. It should be placed in the middle of the DUTs (in front of DUT 8).</p> <p>Bear in mind that the Anritsu MT8852B Bluetooth® LE tester cannot perform TX measurements if the signal received at its antenna is less than -50 dBm. For a good measurement, the signal reaching its antenna should be greater than -40 dBm.</p> <p>Therefore, the distance and the placement between the DUTs and the RF antenna are very important. Trial-and-error test should be carried out until the optimal antenna position is found.</p> <p>The RF antenna placement should be very stable. After the optimal position is found, it should be fixed into position and not able to move again.</p>
DUT fixture	<p>The fixture position should be fixed compared to the RF antenna. The fixture should not move in any way to keep the distance between the DUTs, and the RF antenna fixed.</p>

SmartBond Production Line Tool

F.3 Procedure

Table 66 describes the steps to follow to calculate the RF path losses for each different DUT position.

Table 66. Procedure steps

#	Step	Description
1	Open the SmartBond_PLT_CF G.exe PLT configuration executable.	You should configure the PLT so only XTAL trim (without CS Write) and one Golden Unit RF test is enabled.
2	Enable all 16 DUTs	<p>Select the GU COM port and Enumerate the DUT COM port numbers.</p>
3	Enable only the Production tests	<p>Under the General tab, in the Test Options area, enable only the Production tests and disable the Memory programming.</p>
4	Enable XTAL trim and one Golden Unit RF test at middle band at 2440 MHz.	<p>RSSI and PER limits do not matter. These should be set to a small value (less than -70 dBm) as shown below. Ideally, the limits should be set to a value that all RF tests PASS.</p>

SmartBond Production Line Tool

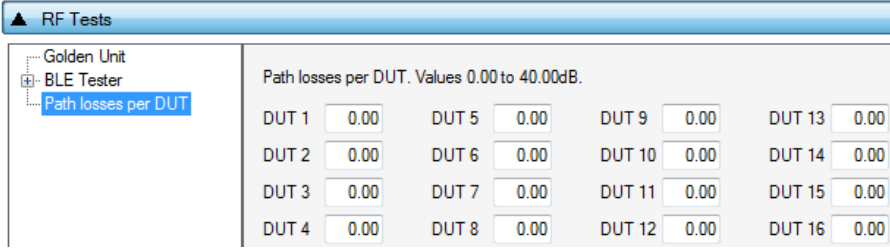
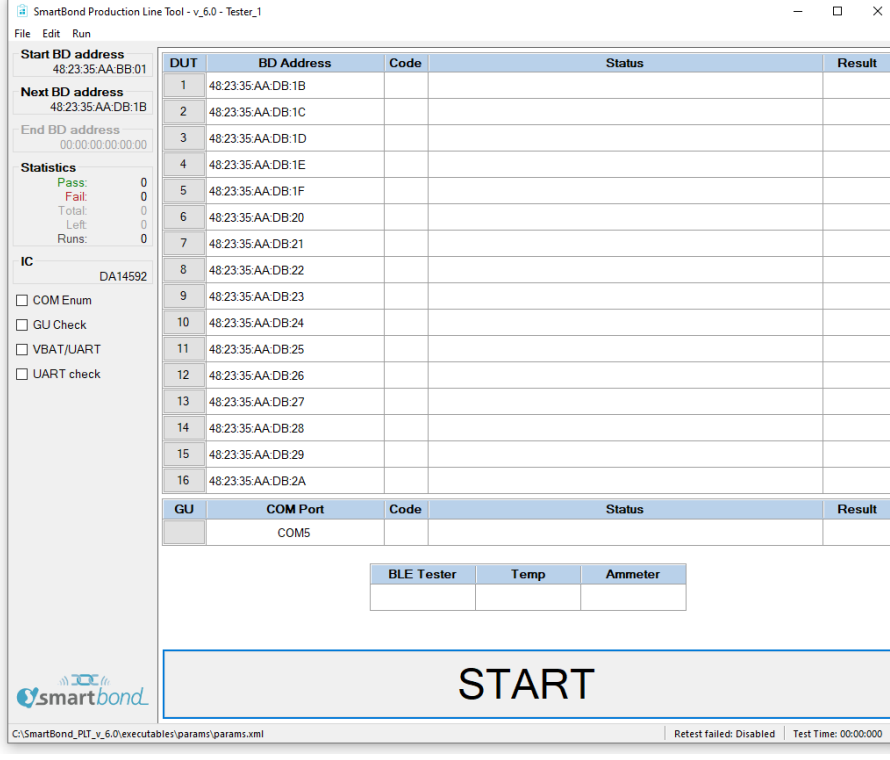
#	Step	Description																																																																																															
5	Set all DUT path losses to 0 dB.	 <p>RF Tests</p> <p>Golden Unit BLE Tester Path losses per DUT</p> <p>Path losses per DUT. Values 0.00 to 40.00dB.</p> <table border="1"> <tr> <td>DUT 1</td><td>0.00</td> <td>DUT 5</td><td>0.00</td> <td>DUT 9</td><td>0.00</td> <td>DUT 13</td><td>0.00</td> </tr> <tr> <td>DUT 2</td><td>0.00</td> <td>DUT 6</td><td>0.00</td> <td>DUT 10</td><td>0.00</td> <td>DUT 14</td><td>0.00</td> </tr> <tr> <td>DUT 3</td><td>0.00</td> <td>DUT 7</td><td>0.00</td> <td>DUT 11</td><td>0.00</td> <td>DUT 15</td><td>0.00</td> </tr> <tr> <td>DUT 4</td><td>0.00</td> <td>DUT 8</td><td>0.00</td> <td>DUT 12</td><td>0.00</td> <td>DUT 16</td><td>0.00</td> </tr> </table>	DUT 1	0.00	DUT 5	0.00	DUT 9	0.00	DUT 13	0.00	DUT 2	0.00	DUT 6	0.00	DUT 10	0.00	DUT 14	0.00	DUT 3	0.00	DUT 7	0.00	DUT 11	0.00	DUT 15	0.00	DUT 4	0.00	DUT 8	0.00	DUT 12	0.00	DUT 16	0.00																																																															
DUT 1	0.00	DUT 5	0.00	DUT 9	0.00	DUT 13	0.00																																																																																										
DUT 2	0.00	DUT 6	0.00	DUT 10	0.00	DUT 14	0.00																																																																																										
DUT 3	0.00	DUT 7	0.00	DUT 11	0.00	DUT 15	0.00																																																																																										
DUT 4	0.00	DUT 8	0.00	DUT 12	0.00	DUT 16	0.00																																																																																										
6	Backup CSV log file.	<p>Go to SmartBond_PLT_v_x.x\executables\logs and back up the today's CSV file. For example, if today's CSV file is Test_station_1_20240212_csv_results.csv rename it to:</p> <p>Test_station_1_20240212_csv_results_BackUp.csv.</p> <p>Doing so ensures a new CSV file is created at the next PLT test run.</p>																																																																																															
7	Place the 1 st PCBA	Place the 1 st PCBA into the fixture inside the shielded box.																																																																																															
8	Open SmartBond_PLT_GU I.exe	 <p>SmartBond Production Line Tool - v.6.0 - Tester_1</p> <p>File Edit Run</p> <p>Start BD address: 48:23:35:AA:BB:01</p> <p>Next BD address: 48:23:35:AA:DB:1B</p> <p>End BD address: 00:00:00:00:00:00</p> <p>Statistics: Pass: 0, Fail: 0, Total: 0, Left: 0, Runs: 0</p> <p>IC: DA14592</p> <p><input type="checkbox"/> COM Enum <input type="checkbox"/> GU Check <input type="checkbox"/> VBAT/UART <input type="checkbox"/> UART check</p> <table border="1"> <thead> <tr> <th>DUT</th> <th>BD Address</th> <th>Code</th> <th>Status</th> <th>Result</th> </tr> </thead> <tbody> <tr><td>1</td><td>48:23:35:AA:DB:1B</td><td></td><td></td><td></td></tr> <tr><td>2</td><td>48:23:35:AA:DB:1C</td><td></td><td></td><td></td></tr> <tr><td>3</td><td>48:23:35:AA:DB:1D</td><td></td><td></td><td></td></tr> <tr><td>4</td><td>48:23:35:AA:DB:1E</td><td></td><td></td><td></td></tr> <tr><td>5</td><td>48:23:35:AA:DB:1F</td><td></td><td></td><td></td></tr> <tr><td>6</td><td>48:23:35:AA:DB:20</td><td></td><td></td><td></td></tr> <tr><td>7</td><td>48:23:35:AA:DB:21</td><td></td><td></td><td></td></tr> <tr><td>8</td><td>48:23:35:AA:DB:22</td><td></td><td></td><td></td></tr> <tr><td>9</td><td>48:23:35:AA:DB:23</td><td></td><td></td><td></td></tr> <tr><td>10</td><td>48:23:35:AA:DB:24</td><td></td><td></td><td></td></tr> <tr><td>11</td><td>48:23:35:AA:DB:25</td><td></td><td></td><td></td></tr> <tr><td>12</td><td>48:23:35:AA:DB:26</td><td></td><td></td><td></td></tr> <tr><td>13</td><td>48:23:35:AA:DB:27</td><td></td><td></td><td></td></tr> <tr><td>14</td><td>48:23:35:AA:DB:28</td><td></td><td></td><td></td></tr> <tr><td>15</td><td>48:23:35:AA:DB:29</td><td></td><td></td><td></td></tr> <tr><td>16</td><td>48:23:35:AA:DB:2A</td><td></td><td></td><td></td></tr> </tbody> </table> <table border="1"> <thead> <tr> <th>GU</th> <th>COM Port</th> <th>Code</th> <th>Status</th> <th>Result</th> </tr> </thead> <tbody> <tr> <td></td> <td>COM5</td> <td></td> <td></td> <td></td> </tr> </tbody> </table> <p>BLE Tester Temp Ammeter</p> <p>START</p> <p>C:\SmartBond_PLT_v_6.0\executables\params\params.xml Retest failed: Disabled Test Time: 00:00:00</p>	DUT	BD Address	Code	Status	Result	1	48:23:35:AA:DB:1B				2	48:23:35:AA:DB:1C				3	48:23:35:AA:DB:1D				4	48:23:35:AA:DB:1E				5	48:23:35:AA:DB:1F				6	48:23:35:AA:DB:20				7	48:23:35:AA:DB:21				8	48:23:35:AA:DB:22				9	48:23:35:AA:DB:23				10	48:23:35:AA:DB:24				11	48:23:35:AA:DB:25				12	48:23:35:AA:DB:26				13	48:23:35:AA:DB:27				14	48:23:35:AA:DB:28				15	48:23:35:AA:DB:29				16	48:23:35:AA:DB:2A				GU	COM Port	Code	Status	Result		COM5			
DUT	BD Address	Code	Status	Result																																																																																													
1	48:23:35:AA:DB:1B																																																																																																
2	48:23:35:AA:DB:1C																																																																																																
3	48:23:35:AA:DB:1D																																																																																																
4	48:23:35:AA:DB:1E																																																																																																
5	48:23:35:AA:DB:1F																																																																																																
6	48:23:35:AA:DB:20																																																																																																
7	48:23:35:AA:DB:21																																																																																																
8	48:23:35:AA:DB:22																																																																																																
9	48:23:35:AA:DB:23																																																																																																
10	48:23:35:AA:DB:24																																																																																																
11	48:23:35:AA:DB:25																																																																																																
12	48:23:35:AA:DB:26																																																																																																
13	48:23:35:AA:DB:27																																																																																																
14	48:23:35:AA:DB:28																																																																																																
15	48:23:35:AA:DB:29																																																																																																
16	48:23:35:AA:DB:2A																																																																																																
GU	COM Port	Code	Status	Result																																																																																													
	COM5																																																																																																

SmartBond Production Line Tool

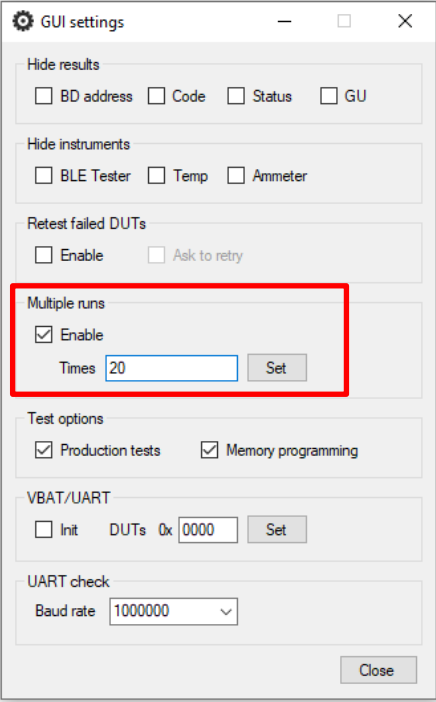
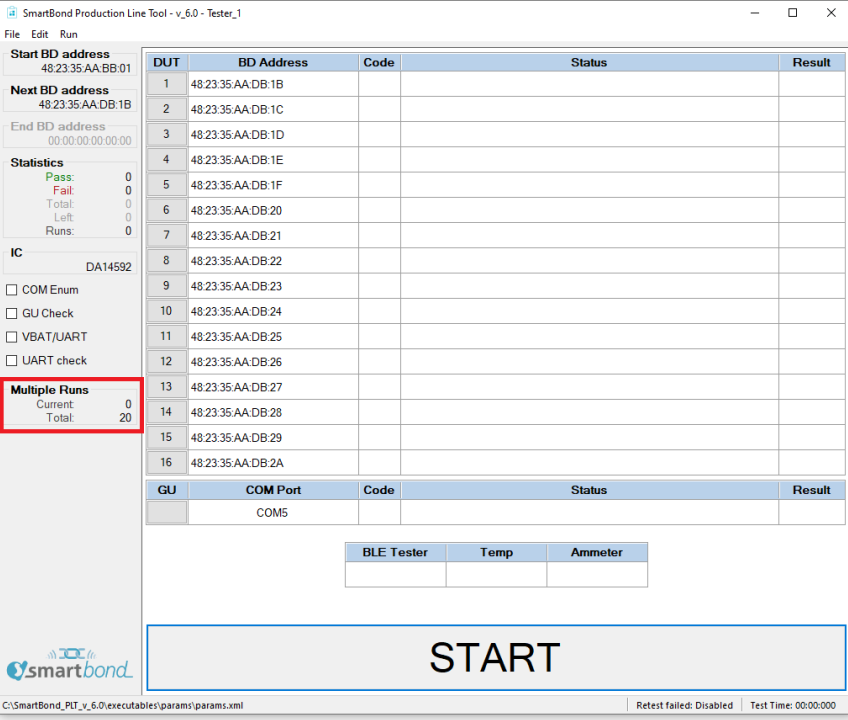
#	Step	Description
9	Go to Edit > Settings	<p>In Multiple runs, select Enable and in Times enter 20 and click Set, and then click Close.</p> 
10	In the SmartBond_PLT_GU I .exe the Multiple Runs should be shown on the left panel	
11	Click START	Click START and wait for the 20 tests to be performed.

SmartBond Production Line Tool

#	Step	Description																																																																																																																																																																																																																																																																																																
12	Backup CSV log file	Go to SmartBond_PLT_v_x.x\executables\logs and back up the CSV file for the 1 st PCBA. For example, if today's CSV file is Test_station_1_20240212_csv_results.csv rename it to Test_station_1_20240212_csv_results_PCBA_1.csv.																																																																																																																																																																																																																																																																																																
13	Place the 2 nd PCBA	Place the 2 nd PCBA into the fixture inside the shielded box.																																																																																																																																																																																																																																																																																																
14	Repeat steps	Repeat the procedure from step 9 to step 13 for all 10 PCBAs.																																																																																																																																																																																																																																																																																																
15	Check CSV results	<p>At the end, 10 CSV logs files should exist. For example,</p> <p>Test_station_1_20180306_csv_results_PCBA_1.csv. Test_station_1_20180306_csv_results_PCBA_2.csv. ... Test_station_1_20180306_csv_results_PCBA_10.csv.</p> <p>Each CSV file should have 16 DUTs * 20 Tests = 320 lines + 1 CSV header = 321 lines. Example:</p> <table border="1"> <thead> <tr> <th></th> <th>A</th> <th>B</th> <th>C</th> <th>D</th> <th>E</th> <th>F</th> <th>G</th> <th>H</th> <th>I</th> <th>J</th> <th>K</th> <th>L</th> <th>M</th> <th>N</th> <th>O</th> </tr> </thead> <tbody> <tr> <td>1</td> <td>Start time</td> <td>End time</td> <td>DUT</td> <td>BD address</td> <td>Overall</td> <td>COM</td> <td>FW do</td> <td>FW path 1</td> <td>FW ve</td> <td>FW versio</td> <td>XTAL tri</td> <td>XTAL t</td> <td>GU RX</td> <td>GU RX</td> <td>RSS GU RX</td> </tr> <tr> <td>2</td> <td>11:20:33</td> <td>11:20:47</td> <td>1</td> <td>00:00:00:0</td> <td>PASS</td> <td>20</td> <td>PASS</td> <td>C:\Users\{PASS</td> <td>v_5.0.4_Pi</td> <td>PASS</td> <td>1172</td> <td>PASS</td> <td></td> <td></td> <td>-28.5</td> </tr> <tr> <td>3</td> <td>11:20:33</td> <td>11:20:47</td> <td>2</td> <td>00:00:00:0</td> <td>PASS</td> <td>12</td> <td>PASS</td> <td>C:\Users\{PASS</td> <td>v_5.0.4_Pi</td> <td>PASS</td> <td>1207</td> <td>PASS</td> <td></td> <td></td> <td>-26.61</td> </tr> <tr> <td>4</td> <td>11:20:33</td> <td>11:20:47</td> <td>3</td> <td>00:00:00:0</td> <td>PASS</td> <td>18</td> <td>PASS</td> <td>C:\Users\{PASS</td> <td>v_5.0.4_Pi</td> <td>PASS</td> <td>1272</td> <td>PASS</td> <td></td> <td></td> <td>-26.61</td> </tr> <tr> <td>5</td> <td>11:20:33</td> <td>11:20:47</td> <td>4</td> <td>00:00:00:0</td> <td>PASS</td> <td>13</td> <td>PASS</td> <td>C:\Users\{PASS</td> <td>v_5.0.4_Pi</td> <td>PASS</td> <td>1222</td> <td>PASS</td> <td></td> <td></td> <td>-28.5</td> </tr> <tr> <td>6</td> <td>11:20:33</td> <td>11:20:47</td> <td>5</td> <td>00:00:00:0</td> <td>PASS</td> <td>11</td> <td>PASS</td> <td>C:\Users\{PASS</td> <td>v_5.0.4_Pi</td> <td>PASS</td> <td>1181</td> <td>PASS</td> <td></td> <td></td> <td>-26.13</td> </tr> <tr> <td>7</td> <td>11:20:33</td> <td>11:20:47</td> <td>6</td> <td>00:00:00:0</td> <td>PASS</td> <td>10</td> <td>PASS</td> <td>C:\Users\{PASS</td> <td>v_5.0.4_Pi</td> <td>PASS</td> <td>1218</td> <td>PASS</td> <td></td> <td></td> <td>-22.34</td> </tr> <tr> <td>8</td> <td>11:20:33</td> <td>11:20:47</td> <td>7</td> <td>00:00:00:0</td> <td>PASS</td> <td>9</td> <td>PASS</td> <td>C:\Users\{PASS</td> <td>v_5.0.4_Pi</td> <td>PASS</td> <td>1237</td> <td>PASS</td> <td></td> <td></td> <td>-28.98</td> </tr> <tr> <td>9</td> <td>11:20:33</td> <td>11:20:47</td> <td>8</td> <td>00:00:00:0</td> <td>PASS</td> <td>19</td> <td>PASS</td> <td>C:\Users\{PASS</td> <td>v_5.0.4_Pi</td> <td>PASS</td> <td>1180</td> <td>PASS</td> <td></td> <td></td> <td>-38.93</td> </tr> <tr> <td>10</td> <td>11:20:33</td> <td>11:20:47</td> <td>9</td> <td>00:00:00:0</td> <td>PASS</td> <td>14</td> <td>PASS</td> <td>C:\Users\{PASS</td> <td>v_5.0.4_Pi</td> <td>PASS</td> <td>1207</td> <td>PASS</td> <td></td> <td></td> <td>-27.08</td> </tr> <tr> <td>11</td> <td>11:20:33</td> <td>11:20:47</td> <td>10</td> <td>00:00:00:0</td> <td>PASS</td> <td>15</td> <td>PASS</td> <td>C:\Users\{PASS</td> <td>v_5.0.4_Pi</td> <td>PASS</td> <td>1244</td> <td>PASS</td> <td></td> <td></td> <td>-36.09</td> </tr> <tr> <td>12</td> <td>11:20:33</td> <td>11:20:47</td> <td>11</td> <td>00:00:00:0</td> <td>PASS</td> <td>16</td> <td>PASS</td> <td>C:\Users\{PASS</td> <td>v_5.0.4_Pi</td> <td>PASS</td> <td>1180</td> <td>PASS</td> <td></td> <td></td> <td>-34.19</td> </tr> <tr> <td>13</td> <td>11:20:33</td> <td>11:20:47</td> <td>12</td> <td>00:00:00:0</td> <td>PASS</td> <td>17</td> <td>PASS</td> <td>C:\Users\{PASS</td> <td>v_5.0.4_Pi</td> <td>PASS</td> <td>1168</td> <td>PASS</td> <td></td> <td></td> <td>-27.08</td> </tr> <tr> <td>14</td> <td>11:20:33</td> <td>11:20:47</td> <td>13</td> <td>00:00:00:0</td> <td>PASS</td> <td>5</td> <td>PASS</td> <td>C:\Users\{PASS</td> <td>v_5.0.4_Pi</td> <td>PASS</td> <td>1255</td> <td>PASS</td> <td></td> <td></td> <td>-32.29</td> </tr> <tr> <td>15</td> <td>11:20:33</td> <td>11:20:47</td> <td>14</td> <td>00:00:00:0</td> <td>PASS</td> <td>6</td> <td>PASS</td> <td>C:\Users\{PASS</td> <td>v_5.0.4_Pi</td> <td>PASS</td> <td>1247</td> <td>PASS</td> <td></td> <td></td> <td>-23.76</td> </tr> <tr> <td>16</td> <td>11:20:33</td> <td>11:20:47</td> <td>15</td> <td>00:00:00:0</td> <td>PASS</td> <td>7</td> <td>PASS</td> <td>C:\Users\{PASS</td> <td>v_5.0.4_Pi</td> <td>PASS</td> <td>1180</td> <td>PASS</td> <td></td> <td></td> <td>-24.71</td> </tr> <tr> <td>17</td> <td>11:20:33</td> <td>11:20:47</td> <td>16</td> <td>00:00:00:0</td> <td>PASS</td> <td>8</td> <td>PASS</td> <td>C:\Users\{PASS</td> <td>v_5.0.4_Pi</td> <td>PASS</td> <td>1247</td> <td>PASS</td> <td></td> <td></td> <td>-28.98</td> </tr> </tbody> </table>		A	B	C	D	E	F	G	H	I	J	K	L	M	N	O	1	Start time	End time	DUT	BD address	Overall	COM	FW do	FW path 1	FW ve	FW versio	XTAL tri	XTAL t	GU RX	GU RX	RSS GU RX	2	11:20:33	11:20:47	1	00:00:00:0	PASS	20	PASS	C:\Users\{PASS	v_5.0.4_Pi	PASS	1172	PASS			-28.5	3	11:20:33	11:20:47	2	00:00:00:0	PASS	12	PASS	C:\Users\{PASS	v_5.0.4_Pi	PASS	1207	PASS			-26.61	4	11:20:33	11:20:47	3	00:00:00:0	PASS	18	PASS	C:\Users\{PASS	v_5.0.4_Pi	PASS	1272	PASS			-26.61	5	11:20:33	11:20:47	4	00:00:00:0	PASS	13	PASS	C:\Users\{PASS	v_5.0.4_Pi	PASS	1222	PASS			-28.5	6	11:20:33	11:20:47	5	00:00:00:0	PASS	11	PASS	C:\Users\{PASS	v_5.0.4_Pi	PASS	1181	PASS			-26.13	7	11:20:33	11:20:47	6	00:00:00:0	PASS	10	PASS	C:\Users\{PASS	v_5.0.4_Pi	PASS	1218	PASS			-22.34	8	11:20:33	11:20:47	7	00:00:00:0	PASS	9	PASS	C:\Users\{PASS	v_5.0.4_Pi	PASS	1237	PASS			-28.98	9	11:20:33	11:20:47	8	00:00:00:0	PASS	19	PASS	C:\Users\{PASS	v_5.0.4_Pi	PASS	1180	PASS			-38.93	10	11:20:33	11:20:47	9	00:00:00:0	PASS	14	PASS	C:\Users\{PASS	v_5.0.4_Pi	PASS	1207	PASS			-27.08	11	11:20:33	11:20:47	10	00:00:00:0	PASS	15	PASS	C:\Users\{PASS	v_5.0.4_Pi	PASS	1244	PASS			-36.09	12	11:20:33	11:20:47	11	00:00:00:0	PASS	16	PASS	C:\Users\{PASS	v_5.0.4_Pi	PASS	1180	PASS			-34.19	13	11:20:33	11:20:47	12	00:00:00:0	PASS	17	PASS	C:\Users\{PASS	v_5.0.4_Pi	PASS	1168	PASS			-27.08	14	11:20:33	11:20:47	13	00:00:00:0	PASS	5	PASS	C:\Users\{PASS	v_5.0.4_Pi	PASS	1255	PASS			-32.29	15	11:20:33	11:20:47	14	00:00:00:0	PASS	6	PASS	C:\Users\{PASS	v_5.0.4_Pi	PASS	1247	PASS			-23.76	16	11:20:33	11:20:47	15	00:00:00:0	PASS	7	PASS	C:\Users\{PASS	v_5.0.4_Pi	PASS	1180	PASS			-24.71	17	11:20:33	11:20:47	16	00:00:00:0	PASS	8	PASS	C:\Users\{PASS	v_5.0.4_Pi	PASS	1247	PASS			-28.98
	A	B	C	D	E	F	G	H	I	J	K	L	M	N	O																																																																																																																																																																																																																																																																																			
1	Start time	End time	DUT	BD address	Overall	COM	FW do	FW path 1	FW ve	FW versio	XTAL tri	XTAL t	GU RX	GU RX	RSS GU RX																																																																																																																																																																																																																																																																																			
2	11:20:33	11:20:47	1	00:00:00:0	PASS	20	PASS	C:\Users\{PASS	v_5.0.4_Pi	PASS	1172	PASS			-28.5																																																																																																																																																																																																																																																																																			
3	11:20:33	11:20:47	2	00:00:00:0	PASS	12	PASS	C:\Users\{PASS	v_5.0.4_Pi	PASS	1207	PASS			-26.61																																																																																																																																																																																																																																																																																			
4	11:20:33	11:20:47	3	00:00:00:0	PASS	18	PASS	C:\Users\{PASS	v_5.0.4_Pi	PASS	1272	PASS			-26.61																																																																																																																																																																																																																																																																																			
5	11:20:33	11:20:47	4	00:00:00:0	PASS	13	PASS	C:\Users\{PASS	v_5.0.4_Pi	PASS	1222	PASS			-28.5																																																																																																																																																																																																																																																																																			
6	11:20:33	11:20:47	5	00:00:00:0	PASS	11	PASS	C:\Users\{PASS	v_5.0.4_Pi	PASS	1181	PASS			-26.13																																																																																																																																																																																																																																																																																			
7	11:20:33	11:20:47	6	00:00:00:0	PASS	10	PASS	C:\Users\{PASS	v_5.0.4_Pi	PASS	1218	PASS			-22.34																																																																																																																																																																																																																																																																																			
8	11:20:33	11:20:47	7	00:00:00:0	PASS	9	PASS	C:\Users\{PASS	v_5.0.4_Pi	PASS	1237	PASS			-28.98																																																																																																																																																																																																																																																																																			
9	11:20:33	11:20:47	8	00:00:00:0	PASS	19	PASS	C:\Users\{PASS	v_5.0.4_Pi	PASS	1180	PASS			-38.93																																																																																																																																																																																																																																																																																			
10	11:20:33	11:20:47	9	00:00:00:0	PASS	14	PASS	C:\Users\{PASS	v_5.0.4_Pi	PASS	1207	PASS			-27.08																																																																																																																																																																																																																																																																																			
11	11:20:33	11:20:47	10	00:00:00:0	PASS	15	PASS	C:\Users\{PASS	v_5.0.4_Pi	PASS	1244	PASS			-36.09																																																																																																																																																																																																																																																																																			
12	11:20:33	11:20:47	11	00:00:00:0	PASS	16	PASS	C:\Users\{PASS	v_5.0.4_Pi	PASS	1180	PASS			-34.19																																																																																																																																																																																																																																																																																			
13	11:20:33	11:20:47	12	00:00:00:0	PASS	17	PASS	C:\Users\{PASS	v_5.0.4_Pi	PASS	1168	PASS			-27.08																																																																																																																																																																																																																																																																																			
14	11:20:33	11:20:47	13	00:00:00:0	PASS	5	PASS	C:\Users\{PASS	v_5.0.4_Pi	PASS	1255	PASS			-32.29																																																																																																																																																																																																																																																																																			
15	11:20:33	11:20:47	14	00:00:00:0	PASS	6	PASS	C:\Users\{PASS	v_5.0.4_Pi	PASS	1247	PASS			-23.76																																																																																																																																																																																																																																																																																			
16	11:20:33	11:20:47	15	00:00:00:0	PASS	7	PASS	C:\Users\{PASS	v_5.0.4_Pi	PASS	1180	PASS			-24.71																																																																																																																																																																																																																																																																																			
17	11:20:33	11:20:47	16	00:00:00:0	PASS	8	PASS	C:\Users\{PASS	v_5.0.4_Pi	PASS	1247	PASS			-28.98																																																																																																																																																																																																																																																																																			

SmartBond Production Line Tool

#	Step	Description																																																			
16	Get the average for each DUT in each CSV file	In each CSV file, get the average GU RX RSSI value for each DUT. Apply the following formulas to each of the 10 CSV files.																																																			
		<table border="1"> <thead> <tr> <th>DUT #</th> <th>Formula</th> <th>Example Result</th> </tr> </thead> <tbody> <tr> <td>DUT 1</td> <td>=SUMIF(\$C\$2:\$C\$321,1,\$N\$2:\$N\$321)/20</td> <td>-28.5015</td> </tr> <tr> <td>DUT 2</td> <td>=SUMIF(\$C\$2:\$C\$321,2,\$N\$2:\$N\$321)/20</td> <td>-26.609</td> </tr> <tr> <td>DUT 3</td> <td>=SUMIF(\$C\$2:\$C\$321,3,\$N\$2:\$N\$321)/20</td> <td>-26.8685</td> </tr> <tr> <td>DUT 4</td> <td>=SUMIF(\$C\$2:\$C\$321,4,\$N\$2:\$N\$321)/20</td> <td>-28.406</td> </tr> <tr> <td>DUT 5</td> <td>=SUMIF(\$C\$2:\$C\$321,5,\$N\$2:\$N\$321)/20</td> <td>-26.346</td> </tr> <tr> <td>DUT 6</td> <td>=SUMIF(\$C\$2:\$C\$321,6,\$N\$2:\$N\$321)/20</td> <td>-22.5515</td> </tr> <tr> <td>DUT 7</td> <td>=SUMIF(\$C\$2:\$C\$321,7,\$N\$2:\$N\$321)/20</td> <td>-28.98</td> </tr> <tr> <td>DUT 8</td> <td>=SUMIF(\$C\$2:\$C\$321,8,\$N\$2:\$N\$321)/20</td> <td>-39.283</td> </tr> <tr> <td>DUT 9</td> <td>=SUMIF(\$C\$2:\$C\$321,9,\$N\$2:\$N\$321)/20</td> <td>-27.08</td> </tr> <tr> <td>DUT 10</td> <td>=SUMIF(\$C\$2:\$C\$321,10,\$N\$2:\$N\$321)/20</td> <td>-36.607</td> </tr> <tr> <td>DUT 11</td> <td>=SUMIF(\$C\$2:\$C\$321,11,\$N\$2:\$N\$321)/20</td> <td>-34.19</td> </tr> <tr> <td>DUT 12</td> <td>=SUMIF(\$C\$2:\$C\$321,12,\$N\$2:\$N\$321)/20</td> <td>-26.7745</td> </tr> <tr> <td>DUT 13</td> <td>=SUMIF(\$C\$2:\$C\$321,13,\$N\$2:\$N\$321)/20</td> <td>-32.0095</td> </tr> <tr> <td>DUT 14</td> <td>=SUMIF(\$C\$2:\$C\$321,14,\$N\$2:\$N\$321)/20</td> <td>-23.784</td> </tr> <tr> <td>DUT 15</td> <td>=SUMIF(\$C\$2:\$C\$321,15,\$N\$2:\$N\$321)/20</td> <td>-24.71</td> </tr> <tr> <td>DUT 16</td> <td>=SUMIF(\$C\$2:\$C\$321,16,\$N\$2:\$N\$321)/20</td> <td>-29.168</td> </tr> </tbody> </table>	DUT #	Formula	Example Result	DUT 1	=SUMIF(\$C\$2:\$C\$321,1,\$N\$2:\$N\$321)/20	-28.5015	DUT 2	=SUMIF(\$C\$2:\$C\$321,2,\$N\$2:\$N\$321)/20	-26.609	DUT 3	=SUMIF(\$C\$2:\$C\$321,3,\$N\$2:\$N\$321)/20	-26.8685	DUT 4	=SUMIF(\$C\$2:\$C\$321,4,\$N\$2:\$N\$321)/20	-28.406	DUT 5	=SUMIF(\$C\$2:\$C\$321,5,\$N\$2:\$N\$321)/20	-26.346	DUT 6	=SUMIF(\$C\$2:\$C\$321,6,\$N\$2:\$N\$321)/20	-22.5515	DUT 7	=SUMIF(\$C\$2:\$C\$321,7,\$N\$2:\$N\$321)/20	-28.98	DUT 8	=SUMIF(\$C\$2:\$C\$321,8,\$N\$2:\$N\$321)/20	-39.283	DUT 9	=SUMIF(\$C\$2:\$C\$321,9,\$N\$2:\$N\$321)/20	-27.08	DUT 10	=SUMIF(\$C\$2:\$C\$321,10,\$N\$2:\$N\$321)/20	-36.607	DUT 11	=SUMIF(\$C\$2:\$C\$321,11,\$N\$2:\$N\$321)/20	-34.19	DUT 12	=SUMIF(\$C\$2:\$C\$321,12,\$N\$2:\$N\$321)/20	-26.7745	DUT 13	=SUMIF(\$C\$2:\$C\$321,13,\$N\$2:\$N\$321)/20	-32.0095	DUT 14	=SUMIF(\$C\$2:\$C\$321,14,\$N\$2:\$N\$321)/20	-23.784	DUT 15	=SUMIF(\$C\$2:\$C\$321,15,\$N\$2:\$N\$321)/20	-24.71	DUT 16	=SUMIF(\$C\$2:\$C\$321,16,\$N\$2:\$N\$321)/20	-29.168
		DUT #	Formula	Example Result																																																	
		DUT 1	=SUMIF(\$C\$2:\$C\$321,1,\$N\$2:\$N\$321)/20	-28.5015																																																	
		DUT 2	=SUMIF(\$C\$2:\$C\$321,2,\$N\$2:\$N\$321)/20	-26.609																																																	
		DUT 3	=SUMIF(\$C\$2:\$C\$321,3,\$N\$2:\$N\$321)/20	-26.8685																																																	
		DUT 4	=SUMIF(\$C\$2:\$C\$321,4,\$N\$2:\$N\$321)/20	-28.406																																																	
		DUT 5	=SUMIF(\$C\$2:\$C\$321,5,\$N\$2:\$N\$321)/20	-26.346																																																	
		DUT 6	=SUMIF(\$C\$2:\$C\$321,6,\$N\$2:\$N\$321)/20	-22.5515																																																	
		DUT 7	=SUMIF(\$C\$2:\$C\$321,7,\$N\$2:\$N\$321)/20	-28.98																																																	
		DUT 8	=SUMIF(\$C\$2:\$C\$321,8,\$N\$2:\$N\$321)/20	-39.283																																																	
		DUT 9	=SUMIF(\$C\$2:\$C\$321,9,\$N\$2:\$N\$321)/20	-27.08																																																	
		DUT 10	=SUMIF(\$C\$2:\$C\$321,10,\$N\$2:\$N\$321)/20	-36.607																																																	
		DUT 11	=SUMIF(\$C\$2:\$C\$321,11,\$N\$2:\$N\$321)/20	-34.19																																																	
		DUT 12	=SUMIF(\$C\$2:\$C\$321,12,\$N\$2:\$N\$321)/20	-26.7745																																																	
		DUT 13	=SUMIF(\$C\$2:\$C\$321,13,\$N\$2:\$N\$321)/20	-32.0095																																																	
		DUT 14	=SUMIF(\$C\$2:\$C\$321,14,\$N\$2:\$N\$321)/20	-23.784																																																	
DUT 15	=SUMIF(\$C\$2:\$C\$321,15,\$N\$2:\$N\$321)/20	-24.71																																																			
DUT 16	=SUMIF(\$C\$2:\$C\$321,16,\$N\$2:\$N\$321)/20	-29.168																																																			

SmartBond Production Line Tool

#	Step	Description																																																																																																																																																																																											
17	Get all values to a new excel sheet.	<p>Create a new excel sheet. Copy all values created at step 16 from the 10 CSV files to this new excel sheet. An example of all DUT average values from all 10 CSV files is given below. Only 2 decimal digits are shown.</p> <table border="1"> <thead> <tr> <th>DUT</th> <th>PCBA 1</th> <th>PCBA 2</th> <th>PCBA 3</th> <th>PCBA 4</th> <th>PCBA 5</th> <th>PCBA 6</th> <th>PCBA 7</th> <th>PCBA 8</th> <th>PCBA 9</th> <th>PCBA 10</th> </tr> </thead> <tbody> <tr><td>1</td><td>-28.50</td><td>-28.30</td><td>-28.51</td><td>-27.56</td><td>-29.48</td><td>-28.59</td><td>-30.09</td><td>-29.33</td><td>-30.50</td><td>-30.13</td></tr> <tr><td>2</td><td>-26.61</td><td>-26.07</td><td>-27.09</td><td>-26.56</td><td>-27.99</td><td>-27.38</td><td>-28.31</td><td>-27.64</td><td>-28.36</td><td>-28.11</td></tr> <tr><td>3</td><td>-26.87</td><td>-26.71</td><td>-27.65</td><td>-26.71</td><td>-28.64</td><td>-27.84</td><td>-29.14</td><td>-28.43</td><td>-29.54</td><td>-29.14</td></tr> <tr><td>4</td><td>-28.41</td><td>-27.98</td><td>-28.82</td><td>-27.87</td><td>-29.49</td><td>-29.24</td><td>-30.10</td><td>-29.61</td><td>-30.22</td><td>-29.36</td></tr> <tr><td>5</td><td>-26.35</td><td>-25.69</td><td>-26.72</td><td>-26.58</td><td>-26.74</td><td>-26.02</td><td>-27.37</td><td>-26.75</td><td>-27.42</td><td>-27.20</td></tr> <tr><td>6</td><td>-22.55</td><td>-21.60</td><td>-22.68</td><td>-21.81</td><td>-23.32</td><td>-22.33</td><td>-23.82</td><td>-23.77</td><td>-24.45</td><td>-24.19</td></tr> <tr><td>7</td><td>-28.98</td><td>-28.59</td><td>-29.31</td><td>-28.49</td><td>-29.42</td><td>-28.63</td><td>-29.84</td><td>-28.95</td><td>-29.98</td><td>-29.73</td></tr> <tr><td>8</td><td>-39.28</td><td>-39.06</td><td>-39.50</td><td>-38.95</td><td>-39.53</td><td>-39.38</td><td>-40.32</td><td>-40.11</td><td>-40.39</td><td>-39.90</td></tr> <tr><td>9</td><td>-27.08</td><td>-26.64</td><td>-27.68</td><td>-27.07</td><td>-27.76</td><td>-27.28</td><td>-28.40</td><td>-27.51</td><td>-28.89</td><td>-28.75</td></tr> <tr><td>10</td><td>-36.61</td><td>-35.74</td><td>-36.85</td><td>-36.05</td><td>-37.07</td><td>-37.04</td><td>-37.96</td><td>-37.59</td><td>-38.84</td><td>-38.03</td></tr> <tr><td>11</td><td>-34.19</td><td>-33.57</td><td>-35.15</td><td>-34.94</td><td>-36.09</td><td>-35.10</td><td>-36.11</td><td>-35.23</td><td>-36.21</td><td>-35.97</td></tr> <tr><td>12</td><td>-26.77</td><td>-26.51</td><td>-26.90</td><td>-26.65</td><td>-27.33</td><td>-27.11</td><td>-27.40</td><td>-26.67</td><td>-28.03</td><td>-27.26</td></tr> <tr><td>13</td><td>-32.01</td><td>-31.14</td><td>-32.47</td><td>-31.73</td><td>-33.29</td><td>-32.96</td><td>-34.01</td><td>-33.61</td><td>-34.85</td><td>-34.17</td></tr> <tr><td>14</td><td>-23.78</td><td>-23.31</td><td>-24.50</td><td>-23.56</td><td>-24.51</td><td>-24.46</td><td>-24.55</td><td>-23.60</td><td>-25.03</td><td>-24.67</td></tr> <tr><td>15</td><td>-24.71</td><td>-23.89</td><td>-25.39</td><td>-24.82</td><td>-25.46</td><td>-25.37</td><td>-26.24</td><td>-25.42</td><td>-27.09</td><td>-26.94</td></tr> <tr><td>16</td><td>-29.17</td><td>-28.37</td><td>-30.09</td><td>-30.07</td><td>-30.78</td><td>-29.83</td><td>-31.27</td><td>-30.51</td><td>-31.31</td><td>-30.56</td></tr> </tbody> </table>	DUT	PCBA 1	PCBA 2	PCBA 3	PCBA 4	PCBA 5	PCBA 6	PCBA 7	PCBA 8	PCBA 9	PCBA 10	1	-28.50	-28.30	-28.51	-27.56	-29.48	-28.59	-30.09	-29.33	-30.50	-30.13	2	-26.61	-26.07	-27.09	-26.56	-27.99	-27.38	-28.31	-27.64	-28.36	-28.11	3	-26.87	-26.71	-27.65	-26.71	-28.64	-27.84	-29.14	-28.43	-29.54	-29.14	4	-28.41	-27.98	-28.82	-27.87	-29.49	-29.24	-30.10	-29.61	-30.22	-29.36	5	-26.35	-25.69	-26.72	-26.58	-26.74	-26.02	-27.37	-26.75	-27.42	-27.20	6	-22.55	-21.60	-22.68	-21.81	-23.32	-22.33	-23.82	-23.77	-24.45	-24.19	7	-28.98	-28.59	-29.31	-28.49	-29.42	-28.63	-29.84	-28.95	-29.98	-29.73	8	-39.28	-39.06	-39.50	-38.95	-39.53	-39.38	-40.32	-40.11	-40.39	-39.90	9	-27.08	-26.64	-27.68	-27.07	-27.76	-27.28	-28.40	-27.51	-28.89	-28.75	10	-36.61	-35.74	-36.85	-36.05	-37.07	-37.04	-37.96	-37.59	-38.84	-38.03	11	-34.19	-33.57	-35.15	-34.94	-36.09	-35.10	-36.11	-35.23	-36.21	-35.97	12	-26.77	-26.51	-26.90	-26.65	-27.33	-27.11	-27.40	-26.67	-28.03	-27.26	13	-32.01	-31.14	-32.47	-31.73	-33.29	-32.96	-34.01	-33.61	-34.85	-34.17	14	-23.78	-23.31	-24.50	-23.56	-24.51	-24.46	-24.55	-23.60	-25.03	-24.67	15	-24.71	-23.89	-25.39	-24.82	-25.46	-25.37	-26.24	-25.42	-27.09	-26.94	16	-29.17	-28.37	-30.09	-30.07	-30.78	-29.83	-31.27	-30.51	-31.31	-30.56
DUT	PCBA 1	PCBA 2	PCBA 3	PCBA 4	PCBA 5	PCBA 6	PCBA 7	PCBA 8	PCBA 9	PCBA 10																																																																																																																																																																																			
1	-28.50	-28.30	-28.51	-27.56	-29.48	-28.59	-30.09	-29.33	-30.50	-30.13																																																																																																																																																																																			
2	-26.61	-26.07	-27.09	-26.56	-27.99	-27.38	-28.31	-27.64	-28.36	-28.11																																																																																																																																																																																			
3	-26.87	-26.71	-27.65	-26.71	-28.64	-27.84	-29.14	-28.43	-29.54	-29.14																																																																																																																																																																																			
4	-28.41	-27.98	-28.82	-27.87	-29.49	-29.24	-30.10	-29.61	-30.22	-29.36																																																																																																																																																																																			
5	-26.35	-25.69	-26.72	-26.58	-26.74	-26.02	-27.37	-26.75	-27.42	-27.20																																																																																																																																																																																			
6	-22.55	-21.60	-22.68	-21.81	-23.32	-22.33	-23.82	-23.77	-24.45	-24.19																																																																																																																																																																																			
7	-28.98	-28.59	-29.31	-28.49	-29.42	-28.63	-29.84	-28.95	-29.98	-29.73																																																																																																																																																																																			
8	-39.28	-39.06	-39.50	-38.95	-39.53	-39.38	-40.32	-40.11	-40.39	-39.90																																																																																																																																																																																			
9	-27.08	-26.64	-27.68	-27.07	-27.76	-27.28	-28.40	-27.51	-28.89	-28.75																																																																																																																																																																																			
10	-36.61	-35.74	-36.85	-36.05	-37.07	-37.04	-37.96	-37.59	-38.84	-38.03																																																																																																																																																																																			
11	-34.19	-33.57	-35.15	-34.94	-36.09	-35.10	-36.11	-35.23	-36.21	-35.97																																																																																																																																																																																			
12	-26.77	-26.51	-26.90	-26.65	-27.33	-27.11	-27.40	-26.67	-28.03	-27.26																																																																																																																																																																																			
13	-32.01	-31.14	-32.47	-31.73	-33.29	-32.96	-34.01	-33.61	-34.85	-34.17																																																																																																																																																																																			
14	-23.78	-23.31	-24.50	-23.56	-24.51	-24.46	-24.55	-23.60	-25.03	-24.67																																																																																																																																																																																			
15	-24.71	-23.89	-25.39	-24.82	-25.46	-25.37	-26.24	-25.42	-27.09	-26.94																																																																																																																																																																																			
16	-29.17	-28.37	-30.09	-30.07	-30.78	-29.83	-31.27	-30.51	-31.31	-30.56																																																																																																																																																																																			
18	Get the average of each DUT for all PCBAs	<p>Average each DUTs results.</p> <table border="1"> <thead> <tr> <th>DUT</th> <th>=AVERAGE(B1:K1)</th> </tr> </thead> <tbody> <tr><td>DUT 1</td><td>-29.10</td></tr> <tr><td>DUT 2</td><td>-27.41</td></tr> <tr><td>DUT 3</td><td>-28.07</td></tr> <tr><td>DUT 4</td><td>-29.11</td></tr> <tr><td>DUT 5</td><td>-26.68</td></tr> <tr><td>DUT 6</td><td>-23.05</td></tr> <tr><td>DUT 7</td><td>-29.19</td></tr> <tr><td>DUT 8</td><td>-39.64</td></tr> <tr><td>DUT 9</td><td>-27.71</td></tr> <tr><td>DUT 10</td><td>-37.18</td></tr> <tr><td>DUT 11</td><td>-35.26</td></tr> <tr><td>DUT 12</td><td>-27.06</td></tr> <tr><td>DUT 13</td><td>-33.02</td></tr> <tr><td>DUT 14</td><td>-24.20</td></tr> <tr><td>DUT 15</td><td>-25.53</td></tr> <tr><td>DUT 16</td><td>-30.20</td></tr> </tbody> </table>	DUT	=AVERAGE(B1:K1)	DUT 1	-29.10	DUT 2	-27.41	DUT 3	-28.07	DUT 4	-29.11	DUT 5	-26.68	DUT 6	-23.05	DUT 7	-29.19	DUT 8	-39.64	DUT 9	-27.71	DUT 10	-37.18	DUT 11	-35.26	DUT 12	-27.06	DUT 13	-33.02	DUT 14	-24.20	DUT 15	-25.53	DUT 16	-30.20																																																																																																																																																									
DUT	=AVERAGE(B1:K1)																																																																																																																																																																																												
DUT 1	-29.10																																																																																																																																																																																												
DUT 2	-27.41																																																																																																																																																																																												
DUT 3	-28.07																																																																																																																																																																																												
DUT 4	-29.11																																																																																																																																																																																												
DUT 5	-26.68																																																																																																																																																																																												
DUT 6	-23.05																																																																																																																																																																																												
DUT 7	-29.19																																																																																																																																																																																												
DUT 8	-39.64																																																																																																																																																																																												
DUT 9	-27.71																																																																																																																																																																																												
DUT 10	-37.18																																																																																																																																																																																												
DUT 11	-35.26																																																																																																																																																																																												
DUT 12	-27.06																																																																																																																																																																																												
DUT 13	-33.02																																																																																																																																																																																												
DUT 14	-24.20																																																																																																																																																																																												
DUT 15	-25.53																																																																																																																																																																																												
DUT 16	-30.20																																																																																																																																																																																												

SmartBond Production Line Tool

#	Step	Description																																																			
19	Calculate the RF path loss	<p>To calibrate the RF result to -10 dBm we should apply the formula shown in the third column below.</p> <table border="1"> <thead> <tr> <th>DUT</th> <th>=AVERAGE(B1:K1) Row L</th> <th>Path Loss=-10-L1</th> </tr> </thead> <tbody> <tr><td>DUT 1</td><td>-29.10</td><td>19.10</td></tr> <tr><td>DUT 2</td><td>-27.41</td><td>17.41</td></tr> <tr><td>DUT 3</td><td>-28.07</td><td>18.07</td></tr> <tr><td>DUT 4</td><td>-29.11</td><td>19.11</td></tr> <tr><td>DUT 5</td><td>-26.68</td><td>16.68</td></tr> <tr><td>DUT 6</td><td>-23.05</td><td>13.05</td></tr> <tr><td>DUT 7</td><td>-29.19</td><td>19.19</td></tr> <tr><td>DUT 8</td><td>-39.64</td><td>29.64</td></tr> <tr><td>DUT 9</td><td>-27.71</td><td>17.71</td></tr> <tr><td>DUT 10</td><td>-37.18</td><td>27.18</td></tr> <tr><td>DUT 11</td><td>-35.26</td><td>25.26</td></tr> <tr><td>DUT 12</td><td>-27.06</td><td>17.06</td></tr> <tr><td>DUT 13</td><td>-33.02</td><td>23.02</td></tr> <tr><td>DUT 14</td><td>-24.20</td><td>14.20</td></tr> <tr><td>DUT 15</td><td>-25.53</td><td>15.53</td></tr> <tr><td>DUT 16</td><td>-30.20</td><td>20.20</td></tr> </tbody> </table>	DUT	=AVERAGE(B1:K1) Row L	Path Loss=-10-L1	DUT 1	-29.10	19.10	DUT 2	-27.41	17.41	DUT 3	-28.07	18.07	DUT 4	-29.11	19.11	DUT 5	-26.68	16.68	DUT 6	-23.05	13.05	DUT 7	-29.19	19.19	DUT 8	-39.64	29.64	DUT 9	-27.71	17.71	DUT 10	-37.18	27.18	DUT 11	-35.26	25.26	DUT 12	-27.06	17.06	DUT 13	-33.02	23.02	DUT 14	-24.20	14.20	DUT 15	-25.53	15.53	DUT 16	-30.20	20.20
DUT	=AVERAGE(B1:K1) Row L	Path Loss=-10-L1																																																			
DUT 1	-29.10	19.10																																																			
DUT 2	-27.41	17.41																																																			
DUT 3	-28.07	18.07																																																			
DUT 4	-29.11	19.11																																																			
DUT 5	-26.68	16.68																																																			
DUT 6	-23.05	13.05																																																			
DUT 7	-29.19	19.19																																																			
DUT 8	-39.64	29.64																																																			
DUT 9	-27.71	17.71																																																			
DUT 10	-37.18	27.18																																																			
DUT 11	-35.26	25.26																																																			
DUT 12	-27.06	17.06																																																			
DUT 13	-33.02	23.02																																																			
DUT 14	-24.20	14.20																																																			
DUT 15	-25.53	15.53																																																			
DUT 16	-30.20	20.20																																																			
20	Apply the calculated path losses to the SmartBond_CFG_PLT.exe PLT configuration executable.	<p>The screenshot shows a configuration window titled "RF Tests" with a tree view on the left containing "Golden Unit", "BLE Tester", and "Path losses per DUT". The main area displays a table of path losses per DUT with values ranging from 0.00 to 40.00dB.</p> <table border="1"> <thead> <tr> <th colspan="4">Path losses per DUT. Values 0.00 to 40.00dB.</th> </tr> </thead> <tbody> <tr> <td>DUT 1</td><td>19.1</td> <td>DUT 5</td><td>16.68</td> </tr> <tr> <td>DUT 2</td><td>17.41</td> <td>DUT 6</td><td>13.05</td> </tr> <tr> <td>DUT 3</td><td>18.07</td> <td>DUT 7</td><td>19.19</td> </tr> <tr> <td>DUT 4</td><td>19.11</td> <td>DUT 8</td><td>29.64</td> </tr> <tr> <td>DUT 9</td><td>17.71</td> <td>DUT 11</td><td>25.26</td> </tr> <tr> <td>DUT 10</td><td>27.18</td> <td>DUT 12</td><td>17.06</td> </tr> <tr> <td>DUT 13</td><td>32.02</td> <td>DUT 14</td><td>14.2</td> </tr> <tr> <td>DUT 15</td><td>15.53</td> <td>DUT 16</td><td>20.20</td> </tr> </tbody> </table>	Path losses per DUT. Values 0.00 to 40.00dB.				DUT 1	19.1	DUT 5	16.68	DUT 2	17.41	DUT 6	13.05	DUT 3	18.07	DUT 7	19.19	DUT 4	19.11	DUT 8	29.64	DUT 9	17.71	DUT 11	25.26	DUT 10	27.18	DUT 12	17.06	DUT 13	32.02	DUT 14	14.2	DUT 15	15.53	DUT 16	20.20															
Path losses per DUT. Values 0.00 to 40.00dB.																																																					
DUT 1	19.1	DUT 5	16.68																																																		
DUT 2	17.41	DUT 6	13.05																																																		
DUT 3	18.07	DUT 7	19.19																																																		
DUT 4	19.11	DUT 8	29.64																																																		
DUT 9	17.71	DUT 11	25.26																																																		
DUT 10	27.18	DUT 12	17.06																																																		
DUT 13	32.02	DUT 14	14.2																																																		
DUT 15	15.53	DUT 16	20.20																																																		
21	Verify	Repeat steps 10 to 13 with the 10 PCBAs. Check the GU RX RSSI results in the 10 CSV files. The results should be very close to -10 dBm.																																																			

SmartBond Production Line Tool

Appendix G Building Binaries Using Smart Snippets™ Studio

Figure 118 shows an example of building the binary files using smart snippets studio.

In this example the `pxp_reporter` project was built using SmartSnippets™ Studio. Configuration `DA1459x-00-Release_QSPI` was used as shown in Figure 119. The output binary `pxp_reporter.bin` found inside `DA1459x-00-Release_QSPI` folder. The binary output is built as a bootable image by default.

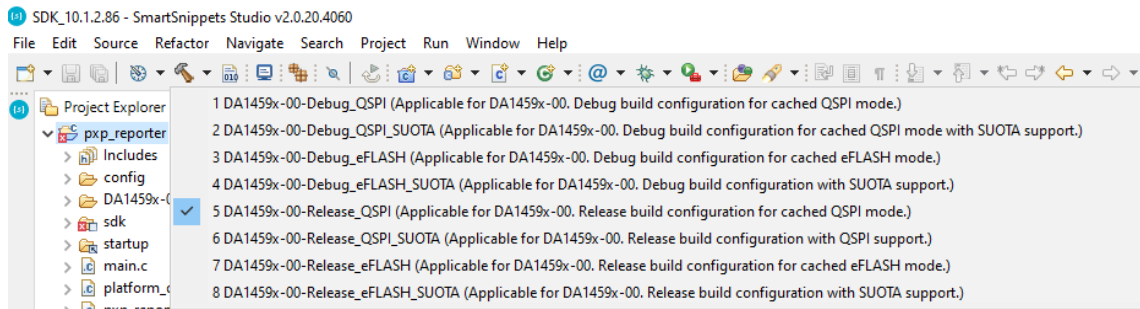



Figure 119. Build `pxp_reporter` using SmartSnippets™ Studio

Appendix H Automatic GU COM Port Find

For the GU COM port automatic recognition to operate, a special serial number should exist in the GU FTDI IC. Usually, this serial number is programmed during PLT PCB manufacturing, but it may not exist in some older versions.

If the GU COM port find operation does not work, then the steps described in should be followed.

Table 67. FTDI DialogSemi serial number

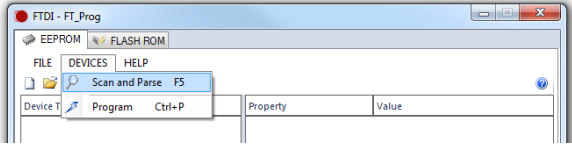
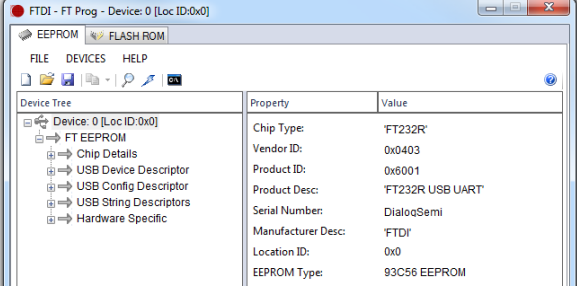
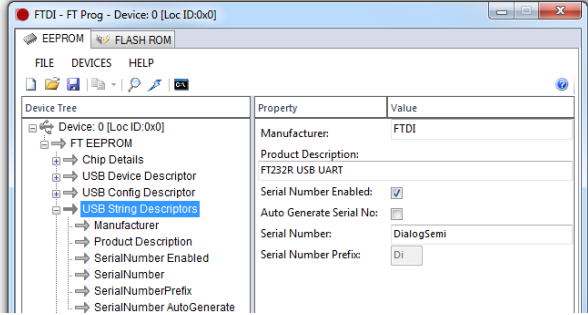
Step	Description
1	Download the FTDI FT_Prog tool from http://www.ftdichip.com/Support/Utilities.htm#FT_PROG .
2	Put power on the PLT board.
3	Remove any other USB FTDI connection to the PC.
4	Connect the USB cable of the GU to the PC.
5	Check the Device Manager that the GU COM port has been found.
6	Run the FT_Prog.exe. 
7	Select Devices > Scan and Parse . 
8	A single FT232 device should be found. 
9	Select USB String Descriptors .
10	Clear Auto Generate Serial No.
11	Edit Serial Number to DialogSemi as shown below. 

SmartBond Production Line Tool

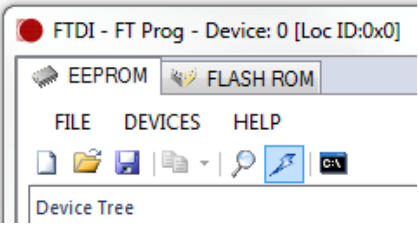
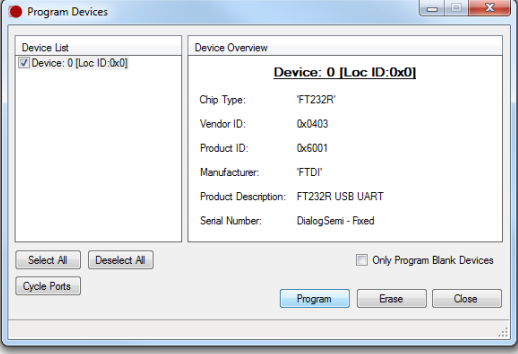
Step	Description
12	To program the change to the FTDI IC, click the Flash button. 
13	In the Program Devices window, . click Program . 
14	Click Close .
15	Unplug and reconnect the GU USB cable to the PC.
16	Verify the Serial Number change by running FT_Prog.exe again and reading the Serial Number value.

Appendix I Improving Cabling Between PLT and DUTs

The following recommendations can be used to improve the connections between PLT and DUTs:

- Keep the lengths of the cables as short as possible.
- When possible, use twisted pair cables instead of separate cables for:
 - GND/VBAT
 - GND/TxD
 - GND/RxD
- Use ferrite beads for noise reduction in cables.



Figure 120. Example of twisted pair cable with 4 pairs and ferrite

- Connect pull-down resistors at the end of the PLT TX signal lines. Use a 4.7 kΩ resistor at PLT DUT Connector Pin 7 (DUT TX) with the other end connected to ground. In total 16 resistors must be mounted, one for each PLT DUT connector.
- Connect a pull-down resistor as close as possible to the UART RX signal connector on the DUT. The value should be approximately 4.7 kΩ. Connect the other end of the resistor to ground.
- Use gold plated contacts in the connections between the PLT and the DUTs.
- Use extra drivers in the UART lines.
- Use series resistors of approximately 100 Ω in the UART lines, one mounted at the beginning and one at the end of the signal lines.

NOTE

Start with the simple solutions first by testing them one-by-one for stability.

Figure 121 and Figure 122 show examples of some of the above proposals.

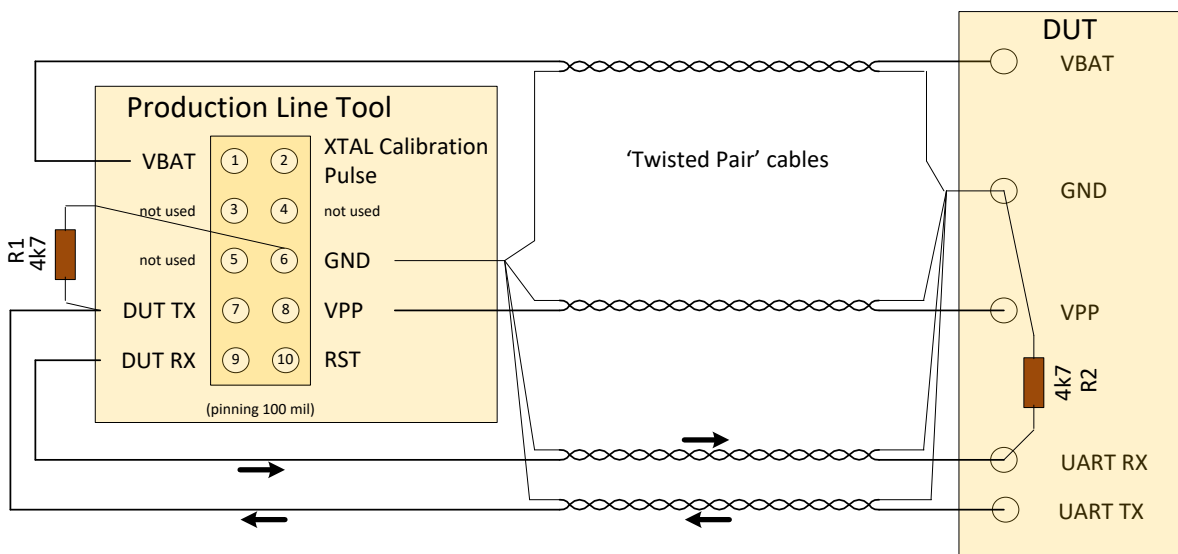

Figure 121. Location of pull-down resistors

SmartBond Production Line Tool

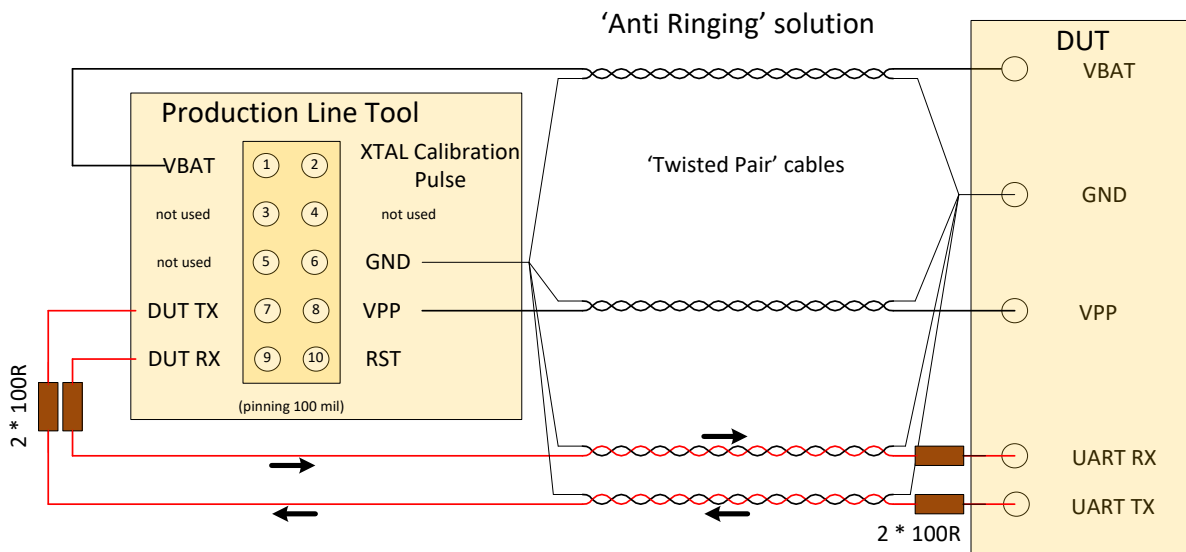

Figure 122. Anti-ringing solution

SmartBond Production Line Tool

Appendix J FTDI Driver Removal and Installation

To re-install the latest FTDI drivers, the previous should be uninstalled.

FTDI driver removal:

1. Download CDM uninstaller from <http://www.ftdichip.com/Support/Utilities.htm#CDMUninstaller>.
2. Run `CDMuninstallerGUI.exe`.
3. Enter these VIDs and PIDs in the CDM Uninstaller and click **Add** for each one.
The VID/PID of the PLT FTDIs are VID=0403/PID=6011 for the DUTs and VID=0403/PID=6001 for the GU.
4. To uninstall the FTDI drivers, click **Remove Devices**.
5. Un-plug both USB cables.

More information can be found in the following link:

http://www.ftdichip.com/Support/Utilities/CDM_Uninst_GUI_Readme.html

FTDI driver installation:

1. Download the latest drivers from <http://www.ftdichip.com/Drivers/VCP.htm> and install them using the executable.
2. After uninstalling the drivers, plug in both USB cables. Windows automatically assigns the new drivers. Do not remove the cables during driver installation. A driver installation error may occur, and the removal-installation have to be repeated.
3. Check in the Windows Device manager that the driver versions of the 17 PLT COM Ports->USB Serial Ports are the latest.

FTDI driver versions v2.12.24, v2.12.26, v2.12.28 and v2.12.36.4 are tested.

SmartBond Production Line Tool**Appendix K DA1459x DK Pro Motherboard Connection**

Figure 123 shows the wiring to a Pro DK motherboard for the DA1459x DUTs. As described in Section 4.4 the following connections are needed to connect a DUT to the PLT:

<https://www.renesas.com/us/en/document/mat/da1459x-development-kit-pro-user-manual>

Table 68. DA1459x Pro DK to PLT connections

Connect function	PLT DUT connector pin number	Pro DK pin number
Ground	DUT connector pin6	Pro DK J3 pin1 (or any available ground pin)
VBAT	DUT connector pin1	Pro DK J9 pin3
UART TX	DUT connector pin7	Pro DK J3 P013
UART RX	DUT connector pin9	Pro DK J3 P015
Reset	DUT connector pin10	Pro DK J3 RSTn

Note 1 The 2 indicated jumpers must be removed. Power supply is provided from the PLT HW (VBAT line).

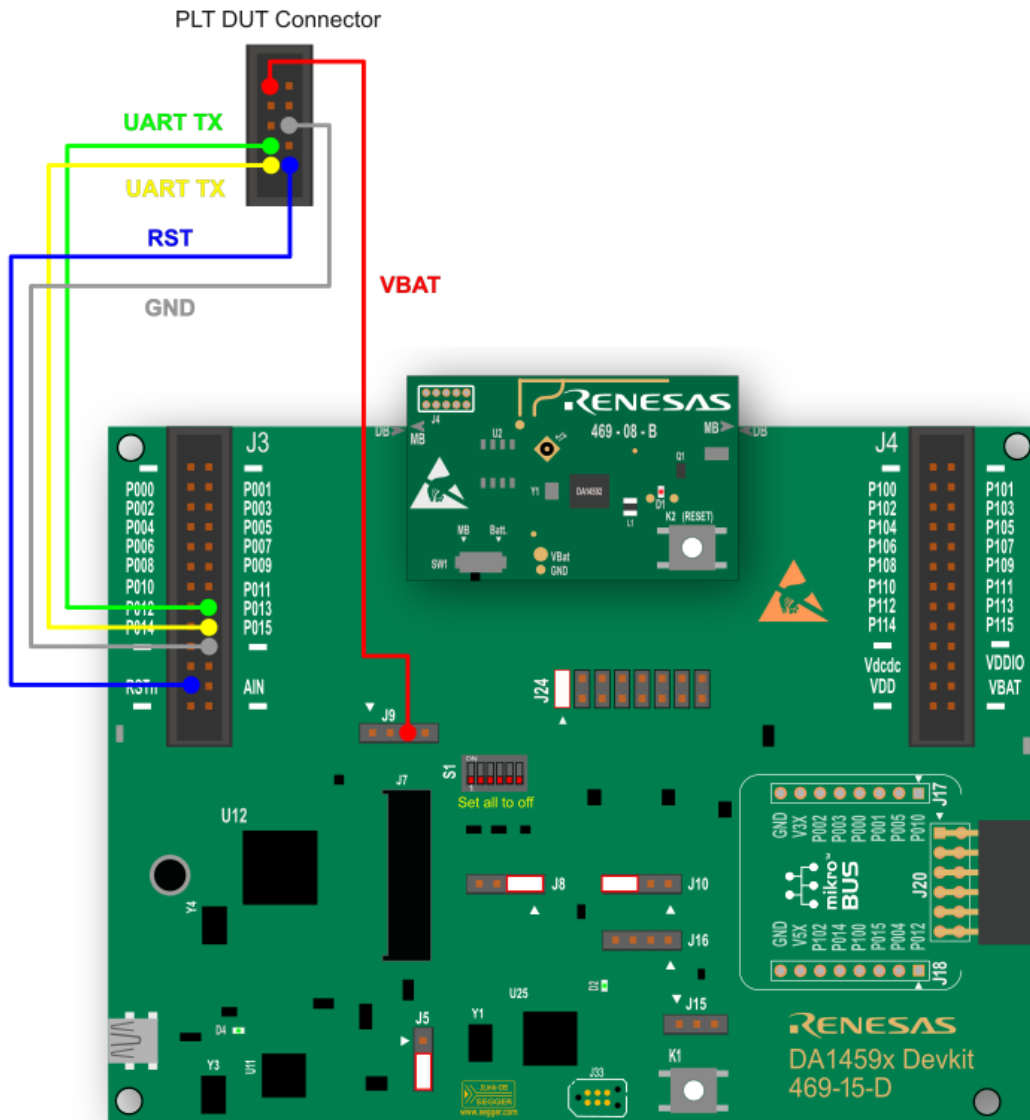

Figure 123. DA1459x Pro Motherboard DK wiring

SmartBond Production Line Tool

Appendix L Connecting DUT with Battery Supply

Wiring connections to a battery powered DUT is described in Section 4.4. Example connections can be found in [Appendix K](#).

- Four wires are mandatory for the connection:
 - Common Ground
 - UART Tx
 - UART Rx
 - Reset line
- VBAT On with Reset mode is the only mode supporting battery powered DUTs since POR cannot be performed. For the PLT to perform a reset on the DUTs, the VBAT line of each DUT connector must be connected to the reset line of the DUT.
- Current measurement is not supported since there is no way to measure the current of the DUTs.

To have the least possible wiring connections, UART Rx line can be used as input GPIO for the pulse used during the XTAL Trim procedure.

Appendix M User Interfaces Shortcut Keys

Table 69. User Interface shortcut keys

Application	Shortcut	Description
CSV File CFG PLT Application (Section 6.2)	Ctrl + S	This shortcut is equivalent to clicking the save button.
GUI PLT Application (Section 6.3)	Spacebar	It is used to select the Start button to start testing.
	F	It is equivalent to clicking the Finished button with the left mouse-click.

Appendix N DA1459x Supported QSPI Flash Memories

Table 70 describes the supported QSPI flash memories for DA1459x devices. To support a QSPI flash memory that is not in the list, follow the instructions in the `README_QSPI.md` file located under `SDK_xx.x.x.xxx\sdk\bsp\memory\` folder to manually add it inside the `uartboot_da1459x.bin` firmware.

Table 70. DA1459x supported QSPI/QSPI Flash memories

Memory vendor	Flash type	Product number
Macronix	QSPI	MX25U3235
Windbond	QSPI	W25Q32JWIM
Windbond	QSPI	W25Q32JWIQ

Appendix O Bluetooth® LE Tester Measurement Results

When using an MT8852B as an external Bluetooth® LE tester instrument for the RF Tests (Section 6.2.6.5), PLT instructs the MT8852B to perform specific tests and then wait for its reply. MT8852B replies with a string, containing the command code of the test performed, followed by the results of the test or an Error Response string (Appendix O.4).

Table 71 shows the result command codes.

The PDF document, located by clicking the following link, describes the format of the result string for each command code, under section 15 – 7.

<https://dl.cdn-anritsu.com/en-au/test-measurement/files/Manuals/Programming-Manual/MT8852B/MT8852B-Bluetooth%20tester-Programming%20Manual%20Rev%20X.pdf>

Table 71. MT8852B Supported Command Codes

Code	Test
LEOP0	TX power
LEICD0	Carrier frequency and Drift
LEMI	Modulation index
ERRLST	Error response

As an example, the test results of DUT1 in the example of CSV Log File Contents (Appendix P) is used.

O.1 TX power

The result of DUT1 for the TX-Power test is:

TRUE;-14.25;-14.25;-14.25;0.10;0;2;PASS

Table 72. MT8852B – Bluetooth® LE TX output power test results

Description	Format	Example
Results valid	TRUE FALSE	TRUE
Packet average power in dBm	floating point	-14.25
Test avg max in dBm	floating point	-14.25
Test avg min in dBm	floating point	-14.25
Test peak to average power in dBm	floating point	0.10
Number of failed packets	integer	0
Number of tested packets	integer	2
Pass/fail result	PASS FAIL	PASS

SmartBond Production Line Tool
O.2 Frequency offset

The result of DUT1 for the Frequency Offset test is:

TRUE;-2.500e+003;2.800e+003;-7.800e+003;-7646;-9.0e+003;-9.0e+003;0;2;PASS;-7646

Table 73. MT8852B – Bluetooth® LE carrier frequency offset and drift test results

Description	Format	Example
Drift rate valid	TRUE FALSE	TRUE
Average Fn	Integer	-2.500e+003
Maximum Positive Fn	Integer	2.800e+003
Minimum Negative Fn	integer	-7.800e+003
Drift rate	integer	-7646
Average drift	integer	-9.0e+003
Maximum drift	integer	-9.0e+003
Packets Failed	integer	0
Packets Tested	integer	2
Pass/fail result	PASS FAIL	PASS
Initial drift rate	integer	-7646

O.3 Modulation index

The result of DUT1 for the Modulation Index test is:

TRUE;282100.00;249100.00;200700.00;248700.00;1.00;0;576;1;1;FAIL;100.00%

The tester responded with FAIL because two tests with different patterns were needed. The overall result of the Modulation Index test is concluded in a second step, after the second payload is tested.

Table 74. MT8852B – Bluetooth® LE modulation characteristics test results

Description	Format	Example
Results valid	TRUE FALSE	TRUE
Delta f1 max in Hz	floating point	282100.00
Delta f1 average in Hz	floating point	249100.00
Delta f2 max in Hz (Delta f1 max lowest for BLR8)	floating point	200700.00
Delta f2 average in Hz (Omitted for BLR8)	floating point	248700.00
Delta f2 avg / delta f1 avg (Omitted for BLR8)	floating point	1.00
Delta f2 max Failed limit (Delta f1 max Failed limit for BLR8)	integer	0
Delta f2 max count(Delta f1 max count for BLR8)	integer	576
Packets failed	integer	1
Packets tested	integer	1
Pass/fail result	PASS FAIL	FAIL
Delta f2 max % pass rate (Delta f1 max % pass rate for BLR8)	floating point	100.00%

SmartBond Production Line Tool

O.4 Error response

If the Bluetooth® LE Tester fails to perform the tests it responds with an error. Table 75 describes the parts of the error message. Click the following link to find more details in Section 4.3 of the relative PDF document:

<https://dl.cdn-anritsu.com/en-au/test-measurement/files/Manuals/Programming-Manual/MT8852B/MT8852B-Bluetooth%20tester-Programming%20Manual%20Rev%20X.pdf>

The format of the response message is

ABCCDDEFGHI IJKK! LLLLLLLL! MMMMMM! NNNNNN! OOOOOO!

A common error response, which is not an actual error, is the message below:

00000000000000!NO ERRORS!NO ERRORS!!!

This is due to the output received signal may be less than -50 dB.

Table 75. MT8852B – error list

Alias	Error	Status	Description
A	CONNECTION ALREADY EXISTS	0	No previous connection
		1	Connection already exists
B	EUT TEST MODE STATE	0	EUT Test mode enabled
		1	EUT Test mode not enabled
CC	EUT HCI ERROR	00	OK
		XX	2-digit hex error code (EUT controlled via RS232)
DD	INTERNAL HCI ERROR	00	OK
		XX	2-digit hexadecimal error code
E	INTERNAL SYNC ERROR	0	OK
		1	Internal HCI synchronization error
F	EUT SYNC ERROR	0	OK
		1	EUT HCI synchronization error (control through RS232)
G	EUT HARDWARE ERROR	0	OK
		1	EUT Reported HCI Hardware error message
H	REQUEST FAILED	0	OK
		1	Request failed (system busy)
II	DSP STATUS Note: Setting of the DSP status code does not set the DDE bit of the event register	00	OK
		01	Searching channel
		02	Searching sync word
		03	Incorrect packet length
		04	No payload
		05	Auto ranging
		06	Incorrect packet
		07	Incorrect packet type
		08	Over range

SmartBond Production Line Tool

Alias	Error	Status	Description
		09	Under range
		10	Invalid payload
		11	Error finding start of packet using power profile
		12	Error locating P0/GFSK sync word
		13	Location of P0/GFSK sync word exceeds allowed limits
		14	Error locating EDR sync word
		15	Location of EDR sync word exceeds allowed limits
		16	Error decoding the packet type field
		17	Modulation mode of PI/4-DQPSK or 8DPSK not specified
		18	pi/4-DQPSK modulation does not match with detected packet type
		19	8DPSK modulation does not match with packet type
		20	Invalid packet type decoded
		21	Unknown packet type decoded
		22	Expected and measured packet lengths do not match
23	Insufficient blocks in packet for measurement		
J	EUT BT ADDRESS	0	OK
		1	EUT Bluetooth Address set (in Manual mode)
KK	HCI COMM STATUS	00	OK
		01	Unknown HCI command
		02	No connection
		03	Hardware failure
		04	Paging timeout
		05	Connection timeout
		06	Unsupported feature parameter
		07	Connection ended by user
		08	Low resource connection ended
		09	Power Off connection ended
		10	Local host connection ended
		11	Unsupported remote feature
		12	Role change not allowed
		13	LMP response timeout
14	IQ modem DAC saturation		
LLLL LLL		Internal core error text (variable length)	
MMM MMM M		EUT core error text (variable length)	

SmartBond Production Line Tool

Alias	Error	Status	Description
NNN NNN N			Last GPIB command that caused a Command error (variable length)
OOO OOO O			Last GPIB command that caused an Execution error (variable length)

Appendix P CSV Log File Contents

Table 76 describes the CSV File columns (Section 6.3.5) generated during PLT testing. In general, not all CSV file columns shown in Table 76 are printed, but only those that relate to the enabled tests and memory operations you selected. An example is given in Appendix P.1.

Table 76. CSV file contents

Header	Value	Description
Start time	hh:mm:ss	Shows the time the test procedure has started.
End time	hh:mm:ss	Shows the time the test procedure has ended.
Tester ID	ID	The tester ID name.
DUT	1-16	The PLT connector for the DUT. Values 1-16.
BD address	XX:XX:XX:XX:XX:XX	The BD address assigned for this device.
Overall status	PASS\FAIL	The overall final test result for this DUT.
COM Port	XX	Windows assigned COM Port
Temperature test	PASS\FAIL	Shows the temperature measured during temperature test. The first column shows the result of the test. The second column shows the temperature measured.
Temperature	xx.xx	
Programmer firmware download 1	PASS\FAIL	uartboot_da1459x_minimal.bin firmware download. The first column shows the result of the programmer firmware download procedure. The second column shows the path to the firmware.
Programmer firmware path 1	C:\folder\to\bin	
Programmer firmware version get 1	PASS\FAIL	The firmware version of the programmer firmware (uartboot_da1459x_minimal.bin). The first column shows the result of the firmware version acquisition. The second column shows the actual firmware version.
Programmer firmware version 1	x.x.x.x	
GPIO Watchdog mem 1 [Test Name]	PASS\FAIL	The GPIO watchdog operation for the programmer firmware (uartboot_da1459x.bin).
RAM firmware download	PASS\FAIL	

SmartBond Production Line Tool

Header	Value	Description
RAM firmware path	C:\path\to\bin	Production test firmware download through memory programming firmware. The first column shows the result of the production test firmware download procedure. The second column shows the path to the firmware.
Firmware version get 1	PASS\FAIL	Production test firmware version. The first column shows the result of the test. The second column shows the production test firmware version read back from each device.
Firmware version 1	for example, v_5.0.4_PLT_v4.3	
GPIO Watchdog [Test Name]	PASS\FAIL	GPIO watchdog toggling test for the production test firmware (st_fw_da1459x.bin).
ADC VBAT	PASS\FAIL	The first column contains the result whether the VBAT was successfully measured. The second column has the level of the VBAT as measured by the internal DUT ADC.
VBAT level	VBAT level	
Timestamp [Test Name]	PASS\FAIL	The first column contains the result whether the manufacturing timestamp read succeeded. The second column has the actual timestamp of the DUT IC.
Timestamp value [Test Name]	Timestamp	
32 kHz Test	PASS\FAIL	Pass or fail result of the external 32 kHz test.
XTAL trim test	PASS\FAIL	Automated XTAL Trim value calculation. The first column shows the result of the test. The second column shows the calculated value in decimal.
XTAL trim	for example, 2775311	
Scan HCI Adv [CH37-9\All]	PASS\FAIL	Scan test using Advertising through HCI. The first column shows the result of the test. The second column shows the calculated value in decimal.
Scan HCI Adv RSSI [CH37-9\All]	The RSSI value measured	
Bluetooth LE TX power test 'X' [Test Name]	PASS\FAIL	TX Power tests using external Bluetooth® LE Tester
Bluetooth LE TX power 'X' [Test Name]	TRUE;-13.16;-13.16;-13.16;0.08;0;2;PASS	
Bluetooth LE TX offset test 'X' [Test Name]	PASS\FAIL	TX Frequency offset tests using external Bluetooth® LE Tester
Bluetooth LE TX offset 'X' [Test Name]	TRUE;-1.100e+003;1.400e+003;-4.000e+003;2902;-3.0e+003;-3.0e+003;0;2;PASS;2503	
Bluetooth LE TX modulation test 'X' [Test Name]	PASS\FAIL	

SmartBond Production Line Tool

Header	Value	Description
Bluetooth LE TX modulation 'X' [Test Name]	TRUE;260600.00;253300.00;216800.00;248000.00;0.98;0;576;1;1;FAIL;100.00%	TX Modulation Index tests using external Bluetooth® LE Tester. The first column shows the result of the test. The second column shows the calculated value.
RX RSSI test 'X' [Test Name]	PASS\FAIL	RX sensitivity tests using external Bluetooth® LE Tester. The first column shows the result of the test. The second column shows the RSSI value measured for this device. The third column shows the Packet Error Rate measured for this device.
Bluetooth LE RX RSSI [Test Name]	The RSSI value measured for this device.	
Bluetooth LE RX PER [Test Name]	The Packet Error Rate measured for this device.	
GU RX RSSI test 'X' [Test Name]	PASS\FAIL	RX sensitivity tests using Golden Unit as Tester. The first column shows the result of the test. The second column shows the RSSI value measured for this device. The third column shows the Packet Error Rate measured for this device.
GU RX RSSI 'X' [Test Name]	The RSSI value measured for this device.	
GU RX PER 'X' [Test Name]	The PER measured for this device.	
GPIO/LED test 'X' [Test Name]	PASS\FAIL	GPIO\LED tests
GPIO connection test 'X' [Test Name]	PASS\FAIL	GPIO connection tests
Sensor test 'X' [Test Name]	PASS\FAIL	Sensor tests
Custom test 'X' [Test Name]	PASS\FAIL	Custom tests
Peripheral test 'X' [Test Name]	PASS\FAIL	Current measurement tests for peripherals. The first column shows the result of the test. The second column shows the calculated value, and the high and low limits used for this test.
Peripheral test current	RES=[xxxxA]. LL=[xxxxA]. HL=[xxxxA].	
Extended\Deep sleep current test	PASS\FAIL	Current measurement test for DUT sleep. The first column shows the result of the test. The second column shows the calculated value, and the high and low limits used for this test.
Extended\Deep sleep current	RES=[xxxxA]. LL=[xxxxA]. HL=[xxxxA].	
Programmer firmware download 2	PASS\FAIL	Memory programming firmware download. The first column shows the result of the production test firmware download procedure. The second column shows the path to the firmware.
Programmer firmware path 2	C:\path\to\bin	
Programmer firmware version get 2	PASS\FAIL	

SmartBond Production Line Tool

Header	Value	Description
Programmer firmware version 2	for example, v_5.0.4_PLT_v4.3	Memory programming firmware version. The first column shows the result of the test. The second column shows the memory programming firmware version read back from each device.
GPIO Watchdog mem 2 [Test Name]	PASS\FAIL	GPIO watchdog toggling test for the production test firmware (st_fw_da1459x.bin)
Flash init [QSPI]	PASS\FAIL	Initialize QSPI Flash memory. The first column shows the result of the test. The second column shows the JEDEC ID read back from the device.
Flash jedec [QSPI]	xxxxxx	
Flash erase 'X' [Test Name]	PASS\FAIL	Erase the EFLASH or QSPI Flash memory test.
Flash burn 'X' [Test Name]	PASS\FAIL	EFLASH or QSPI image write test. The first column shows the result of the test. The second column shows the path to the firmware burnt.
Flash binary 'X' [Test Name]	C:\path\to\bin	
Memory data write	PASS\FAIL	Write any available custom memory test. The first column shows the result of the test. The second columns shows whether the data are given from a CSV file, or the contents written.
Memory data	"Data from CSV file" or "xx..."	
CS Write	PASS\FAIL	Configuration Script area write.
SPI\EFLASH\QSPI Memory read 'X' [Test Name]	PASS\FAIL	Read any part of any available memory. The first column shows the result of the test. The second column shows the contents read back.
Memory read data	xx...	
Scan	PASS\FAIL	Scan test with the DUTs booting and advertising.

SmartBond Production Line Tool

P.1 CSV log file example

Figure 124 shows a CSV log example for two DUTs. The contents are explained in Table 77.

	A	B	C	D	E	F	G	H	I	J	K	L	M
1	Start time	End time	Tester ID	DUT	BD address	Overall status	COM port	Programmer FW download 1	Programmer FW	Programmer FW version get 1	Programmer FW version 1	GPIO Watchdog mem 1 [WD-P1_0]	RAM FW download
2	13:01:13	13:02:06	Tester_1	1	00:00:00:00:00:32	PASS	20	PASS	C:\WORK\PLT\F	PASS	0.0.0.4	FAIL	PASS
3	13:03:07	13:04:00	Tester_1	1	00:00:00:00:00:33	PASS	20	PASS	C:\WORK\PLT\F	PASS	0.0.0.4	PASS	PASS

	N	O	P	Q	R	S	T	U	V	W	X	Y	Z	AA	AB	
	RAM FW path	FW version get 1	FW version 1	GPIO Watchdog [WD-P1_0]	ADC VBAT	VBAT level	Timestamp [TIMESTAMP]	Timestamp value	32KHz Test	XTAL trim	XTAL trim	Scan HCI Adv [CH37]	Scan HCI Adv RSSI [CH37]	GU RX RSSI test 1 [GU_RSSI_1]	GU RX RSSI 1 [GU_RSSI_1]	
	C:\WORK\PLT\	PASS		1.1	PASS	PASS	3291.94	PASS	a5a5a5a5c10200e	PASS	PASS	3300615	PASS	-56.47	PASS	-58
	C:\WORK\PLT\	PASS		1.1	PASS	PASS	3287.19	PASS	a5a5a5a5c10200e	PASS	PASS	3300613	PASS	-56.47	PASS	-58

	AC	AD	AE	AF	AG	AH	AI	AJ	AK	AL	AM
	GU RX PER 1 [GU_RSSI_1]	GPIO/LED test 1 [GPIO_P1_0]	GPIO connection test 1 [P1_0-P1_2]	Custom test 1 [CUST_1]	Programmer FW download 2	Programmer FV	Programmer FW version get 2	Programmer FW version 2	GPIO Watchdog mem 2 [WD-P1_0]	Flash init	Flash jedec
	0	PASS	PASS	PASS	PASS	C:\WORK\PLT\	PASS	0.0.0.4	FAIL	PASS	ef8017
	0.2	PASS	PASS	PASS	PASS	C:\WORK\PLT\	PASS	0.0.0.4	PASS	PASS	ef8017

	AN	AO	AP	AQ	AR	AS	AT	AU
	Flash erase 1 [OQSPI_ER_1]	Flash burn 1 [OQSPI_WR_1]	Flash binary 1 [OQSPI_WR_1]	Memory data write	Memory data	OTP CS burn	OTP Memory read 1 [OTP_RD_ALL_1]	OTP Memory read data 1 [OTP_RD_ALL_1]
	PASS	PASS	binaries\pxp_reporter_da1470x.img	PASS	11223344	FAIL	PASS	ff
	PASS	PASS	binaries\pxp_reporter_da1470x.img	PASS	11223344	FAIL	PASS	ff

Figure 124. Example CSV log file

Table 77. Example CSV log file content analysis

#	Header	Value	Description
A	Start time	4:53:30 PM	The time the tests started.
B	End time	4:55:03 PM	The time the tests finished.
C	Tester ID	Tester_1	Tester ID Entered in configured.
D	DUT	1, 2	The PLT position each device is connected.
E	BD address	00:00:00:00:00:32, 00:00:00:00:00:33	The BD address assigned to each device.
F	Overall status	PASS, PASS	The overall result for each device.
G	COM port	20, 20	The Windows assigned COM port to each device.

SmartBond Production Line Tool

#	Header	Value	Description
H	Programmer firmware download 1	PASS, PASS	Booter firmware (uartboot_da1459x.bin) loaded successfully.
I	Programmer firmware path 1	C:\SmartBond_PLT_v_6.0\executables\binaries\uartboot_da1459x.bin	The path to the booter firmware, uartboot_da1459x.bin.
J	Programmer firmware version get 1	PASS	All devices responded to firmware version request. Version is 0.0.0.4.
K	Programmer firmware version 1	0.0.0.4	
L	GPIO Watchdog mem 1 [WD-P1_0]	PASS	GPIO toggling for watchdog has started. In addition, header has the name assigned to the test.
M	RAM firmware download	PASS	Production test firmware (st_fw_da1459x.bin) downloaded to RAM.
N	RAM firmware Path	C:\SmartBond_Cobalt_v_6.0\executables\binaries\st_fw_da1459x.bin	
O	Firmware version get 1	PASS	All devices responded to firmware version request. All of them have version 1.1.
P	Firmware version 1	1.1	
Q	GPIO Watchdog [WD-P1_0]	PASS	
R	ADC VBAT	PASS	ADC VBAT test success.
S	VBAT level	3291.94, 3287.19	ADC VBAT test result.
T	Timestamp [TIMESTAMP]	PASS	Timestamp read test success.
U	Timestamp value [TIMESTAMP]	a5a5a5a5c10200e940881e1902b ...	Timestamp read value.
V	XTAL Trim test	PASS	XTAL Trim test finished successfully. The calculated value (in decimal) is shown for the first device.
W	XTAL Trim	3300615, 3300613	
X	Scan HCI Adv [CH37]	PASS	

SmartBond Production Line Tool

#	Header	Value	Description
Y	Scan HCI Adv RSSI [CH37]	-37.51, -32.77	Scan test using advertising through HCI commands test finished successfully. Channel 37 is selected, which is also shown on the header. RSSI values, for each device are also shown.
AA	GU RX RSSI test 1 [GU_RSSI_1]	PASS	Reception test 1 using the Golden Unit finished successfully. In addition, the header has the name assigned to the test and the RSSI and packet error rate for each device are shown.
AB	GU RX RSSI 1 [GU_RSSI_1]	-58, -58	
AC	GU RX PER 1 [GU_RSSI_1]	0, 0.2	
AD	GPIO/LED test 1 [GPIO_P1_0]	PASS, PASS	GPIO\LED toggling test finished successfully.
AE	GPIO connection test 1 [P1_0-P1_2]	PASS, PASS	GPIO connection test for GPIOs P1.0 and P1.2. Test finished successfully.
AF	Custom test 1 [CUST_1]	PASS, PASS	Custom test finished successfully.
AG	Programmer firmware download 2	PASS, PASS	Booter firmware (uartboot_da1459x.bin) loaded successfully.
AH	Programmer firmware path 2	C:\SmartBond_PLT_v_6.0\executables\binaries\uartboot_da1459x.bin	The path to the booter firmware, uartboot_da1459x.bin.
AI	Programmer firmware version get 2	PASS, PASS	All devices responded to firmware version request. Version is 0.0.0.4.
AJ	Programmer firmware version 2	0.0.0.4	
AK	GPIO Watchdog mem 1 [WD-P1_0]	PASS, PASS	GPIO toggling for watchdog started. In addition, header has the name assigned to the test.
AL	Flash init	PASS, PASS	Initialization of Flash memory succeeded. The JEDEC ID for both Flash memories is 0xEF8017.
AM	Flash jedec	ef8017, ef8017	
AN	Flash erase 1 [QSPI_ER_1]	PASS, PASS	The flash was erased successfully.

SmartBond Production Line Tool

#	Header	Value	Description
AO	Flash burn 1 [QSPI_WR_1]	PASS, PASS	Flash was programmed successfully. The path to the binary programmed is binaries\\pxp_reporter_da1459x.img.
AP	Flash binary 1 [QSPI_WR_1]	binaries\\pxp_reporter_da1459x  .img	
AQ	Memory data write	PASS, PASS	Custom memory data were programmed successfully. Data to program was 0x11223344.
AR	Memory data	11223344, 11223344	
AS	CS burn	PASS, PASS	The CS was successfully programmed.

SmartBond Production Line Tool

Appendix Q DUT Status Codes

Table 78 contains all the possible status codes a DUT can have, followed by a brief description. The table categorizes the status based on the various states of the DUT during testing and programming.

Table 78. DUT status codes

No.	Status	Description
Generic		
	DUT_NOT_ACTIVE	Device is not active.
1.	DUT_INTERNAL_SYSTEM_ERROR	Internal system error.
2.	DUT_COM_PORT_IDENTIFY_STARTED	COM port identification started.
3.	DUT_COM_PORT_IDENTIFY_OK	COM port identified successfully.
4.	DUT_COM_PORT_IDENTIFY_FAILED	COM port identification failed.
Temperature measurement		
5.	DUT_TEMPERATURE_MEASUREMENT_INIT	Temperature measurement initialized.
6.	DUT_TEMPERATURE_MEASUREMENT_OK	Temperature measurement finished successfully.
7.	DUT_TEMPERATURE_MEASUREMENT_ERROR	Temperature measurement error.
Firmware download		
8.	DUT_UDLL_FW_DOWNLOAD_INIT	UDLL firmware download initialized.
9.	DUT_UDLL_FW_DOWNLOAD_STARTED	UDLL firmware download started successfully.
10.	DUT_UDLL_FW_DOWNLOAD_RETRY	UDLL firmware download retry.
11.	DUT_UDLL_FW_DOWNLOAD_OK	UDLL firmware downloaded successfully.
12.	DUT_UDLL_FW_DOWNLOAD_FAILED	UDLL firmware download failed.
Memory programming - Firmware version		
13.	DUT_UDLL_FW_VER_GET_INIT	UDLL device firmware version acquisition initialized
14.	DUT_UDLL_FW_VER_GET_STARTED	UDLL device firmware version acquisition started.
15.	DUT_UDLL_FW_VER_GET_OK	UDLL device firmware version acquisition completed successfully.
16.	DUT_UDLL_FW_VER_GET_FAILED	UDLL device firmware version acquisition failed.
Memory programming – GPIO watchdog		
17.	DUT_UDLL_GPIO_WD_INIT	UDLL GPIO watchdog operation initialized.
18.	DUT_UDLL_GPIO_WD_STARTED	UDLL GPIO watchdog operation started.
19.	DUT_UDLL_GPIO_WD_OK	UDLL GPIO watchdog operation ended successfully.
20.	DUT_UDLL_GPIO_WD_FAILED	UDLL GPIO watchdog operation failed.
Memory programming – RAM firmware download		
21.	DUT_UDLL_RAM_FW_DOWNLOAD_INIT	UDLL firmware download to RAM initialized
22.	DUT_UDLL_RAM_FW_DOWNLOAD_STARTED	UDLL firmware download to RAM started.

SmartBond Production Line Tool

No.	Status	Description
23.	DUT_UDLL_RAM_FW_DOWNLOAD_OK	UDLL firmware download to RAM completed successfully.
24.	DUT_UDLL_RAM_FW_DOWNLOAD_FAILED	UDLL firmware download to RAM failed.
Production test - Generic errors		
25.	DUT_PDLL_NO_ERROR	PDLL returned success.
26.	DUT_PDLL_PARAMS_ERROR	PDLL Device parameters contain errors.
27.	DUT_PDLL_RX_TIMEOUT	Device did not reply on a PDLL message request.
28.	DUT_PDLL_TX_TIMEOUT	Sending a message to the device failed due to TX timeout.
29.	DUT_PDLL_UNEXPECTED_EVENT	Received an unexpected message from the device.
30.	DUT_PDLL_CANNOT_ALLOCATE_MEMORY	PDLL cannot allocate memory.
31.	DUT_PDLL_INTERNAL_ERROR	PDLL internal system error.
32.	DUT_PDLL_THREAD_CREATION_ERROR	PDLL thread creation error.
33.	DUT_PDLL_INVALID_DBG_PARAMS	PDLL debug library (dbg_dll.dll) access error.
34.	DUT_PDLL_DBG_DLL_ERROR	PDLL invalid debug library (dbg_dll.dll) parameters.
Production test - COM port		
35.	DUT_PDLL_COM_PORT_INIT	PDLL device COM port open initialized.
36.	DUT_PDLL_COM_PORT_START	PDLL device COM port open started.
37.	DUT_PDLL_COM_PORT_OK	PDLL device COM port opened successfully.
38.	DUT_PDLL_COM_PORT_FAILED	PDLL device COM port failed.
Production test - Firmware version		
39.	DUT_PDLL_FW_VERSION_GET_START	PDLL device Firmware version acquisition started.
40.	DUT_PDLL_FW_VERSION_GET_OK	PDLL device Firmware version acquisition completed successfully.
41.	DUT_PDLL_FW_VERSION_GET_FAILED	PDLL device Firmware version acquisition failed.
Production test - GPIO watchdog		
42.	DUT_PDLL_GPIO_WD_INIT	GPIO watchdog operation initialized.
43.	DUT_PDLL_GPIO_WD_START	GPIO watchdog operation started.
44.	DUT_PDLL_GPIO_WD_OK	GPIO watchdog operation ended successfully.
45.	DUT_PDLL_GPIO_WD_FAILED	GPIO watchdog operation failed.
Production test - Timestamp read		
46.	DUT_PDLL_TIMESTAMP_RD_INIT	Initialize timestamp read from EFLASH
47.	DUT_PDLL_TIMESTAMP_RD_START	Timestamp read operation started.
48.	DUT_PDLL_TIMESTAMP_RD_OK	Timestamp read operation ended successfully.
49.	DUT_PDLL_TIMESTAMP_RD_FAILED	Timestamp read operation failed.
Production test - VBAT level read		
50.	DUT_PDLL_ADC_VBAT_INIT	Initialize VBAT level read using internal ADC.

SmartBond Production Line Tool

No.	Status	Description
51.	DUT_PDLL_ADC_VBAT_START	VBAT level read operation started.
52.	DUT_PDLL_ADC_VBAT_OK	VBAT level read operation ended successfully.
53.	DUT_PDLL_ADC_VBAT_FAILED	VBAT level read operation failed.
Production test – TX power level set		
54.	DUT_PDLL_SET_TX_PWR_INIT	Initialize TX power set operation.
55.	DUT_PDLL_SET_TX_PWR_START	TX power set operation started.
56.	DUT_PDLL_SET_TX_PWR_OK	TX power set operation ended successfully.
57.	DUT_PDLL_SET_TX_PWR_FAILED	TX power set operation failed.
Production test - External 32 kHz crystal		
58.	DUT_PDLL_EXT32KHz_TEST_INIT	External 32 kHz test operation initialized.
59.	DUT_PDLL_EXT32KHz_TEST_START	External 32 kHz test operation started.
60.	DUT_PDLL_EXT32KHz_TEST_OK	External 32 kHz test operation ended successfully.
61.	DUT_PDLL_EXT32KHz_TEST_FAILED	External 32 kHz test operation failed.
Production test - XTAL trim		
62.	DUT_PDLL_XTAL_TRIM_INIT	XTAL trim operation initialized.
63.	DUT_PDLL_XTAL_TRIM_START	XTAL trim operation started.
64.	DUT_PDLL_XTAL_TRIM_OK	XTAL trim operation ended successfully.
65.	DUT_PDLL_XTAL_TRIM_OUT_OF_RANGE	XTAL trim failed. Input frequency is out of range.
66.	DUT_PDLL_XTAL_TRIM_FREQ_CAL_NOT_CONNECTED	XTAL trim could not be performed. Could not detect external input frequency.
67.	DUT_PDLL_XTAL_TRIM_WRITE_FAILED	XTAL trim failed. Could not write the calculated value to the CS.
68.	DUT_PDLL_XTAL_TRIM_FAILED	XTAL trim failed.
Production test – Read value written in CS		
69.	DUT_PDLL_XTAL_TRIM_READ_INIT	XTAL trim register read operation initialized.
70.	DUT_PDLL_XTAL_TRIM_READ_START	XTAL trim register read operation started.
71.	DUT_PDLL_XTAL_TRIM_READ_OK	XTAL trim register operation ended successfully.
72.	DUT_PDLL_XTAL_TRIM_READ_FAILED	XTAL trim register operation ended successfully.
Production test - UART resync		
73.	DUT_PDLL_UART_RESYNC_INIT	UART resync process initialized.
74.	DUT_PDLL_UART_RESYNC_START	UART resync process started.
75.	DUT_PDLL_UART_RESYNC_OK	UART resync process completed successfully.
76.	DUT_PDLL_UART_RESYNC_FAILED	UART resync process failed.
Production test - Scan with HCI Bluetooth® LE advertisements test		
77.	DUT_PDLL_BLE_HCI_ADV_START_INIT	Bluetooth® LE HCI advertise start initialized.
78.	DUT_PDLL_BLE_HCI_ADV_START	Bluetooth® LE HCI advertise start started.
79.	DUT_PDLL_BLE_HCI_ADV_START_OK	Bluetooth® LE HCI advertise start success.

SmartBond Production Line Tool

No.	Status	Description
80.	DUT_PDLL_BLE_HCI_ADV_START_FAILED	Bluetooth® LE HCI advertise start failed.
81.	DUT_PDLL_BLE_HCI_ADV_STOP_INIT	Bluetooth® LE HCI advertise stop initialized.
82.	DUT_PDLL_BLE_HCI_ADV_STOP_START	Bluetooth® LE HCI advertise stop started.
83.	DUT_PDLL_BLE_HCI_ADV_STOPPED_OK	Bluetooth® LE HCI advertise stop success.
84.	DUT_PDLL_BLE_HCI_ADV_STOP_FAILED	Bluetooth® LE HCI advertise stop failed.
85.	DUT_PDLL_BLE_HCI_ADV_SCAN_START	Bluetooth® LE HCI advertise scan started.
86.	DUT_PDLL_BLE_HCI_ADV_NOT_YET_FOUND	Bluetooth® LE HCI advertise not yet found.
87.	DUT_PDLL_BLE_HCI_ADV_FOUND	Bluetooth® LE HCI advertise found.
88.	DUT_PDLL_BLE_HCI_ADV_RSSI_FAILED	Bluetooth® LE HCI advertise RSSI failed.
89.	DUT_PDLL_BLE_HCI_ADV_FAILED	Bluetooth® LE HCI advertise failed.
Production test – DUT packet transaction		
90.	DUT_PDLL_PKT_TX_START_INIT	RF packet TX initialized.
91.	DUT_PDLL_PKT_TX_START	RF packet TX start.
92.	DUT_PDLL_PKT_TX_STARTED_OK	RF packet TX started successfully.
93.	DUT_PDLL_PKT_TX_STARTED_FAILED	RF packet TX failed to start.
94.	DUT_PDLL_PKT_TX_ENDED_START	RF packet TX ended successfully.
95.	DUT_PDLL_PKT_TX_ENDED_OK	RF packet TX end initiated.
96.	DUT_PDLL_PKT_TX_ENDED_FAILED	RF packet TX failed to end.
Production test – TX power measurement		
97.	DUT_BLE_TESTER_TX_PWR_PASSED	Bluetooth® LE tester TX power test passed.
98.	DUT_BLE_TESTER_TX_PWR_FAILED	Bluetooth® LE tester TX power test failed.
Production test – TX carrier offset measure		
99.	DUT_BLE_TESTER_TX_OFFS_PASSED	Bluetooth® LE tester TX frequency offset test passed.
100.	DUT_BLE_TESTER_TX_OFFS_FAILED	Bluetooth® LE tester TX frequency offset test failed.
Production test – TX modulation index measure		
101.	DUT_BLE_TESTER_TX_MOD_IDX_PASSED	Bluetooth® LE tester TX modulation index test passed.
102.	DUT_BLE_TESTER_TX_MOD_IDX_FAILED	Bluetooth® LE tester TX modulation index test failed.
Production test – DUT start packet RX		
103.	DUT_PDLL_PKT_RX_STATS_START_INIT	RF RX packet test with statistics start initialized.
104.	DUT_PDLL_PKT_RX_STATS_START	RF RX packet test with statistics start.
105.	DUT_PDLL_PKT_RX_STATS_STARTED_OK	RF RX packet test with statistics started successfully.
106.	DUT_PDLL_PKT_RX_STATS_START_FAILED	RF RX packet test with statistics started failed.
Production test – DUT stop packet RX		
107.	DUT_PDLL_PKT_RX_STATS_STOP_INIT	RF RX packet test with statistics stop initialized.
108.	DUT_PDLL_PKT_RX_STATS_STOP_START	RF RX packet test with statistics stop.
109.	DUT_PDLL_PKT_RX_STATS_STOPPED_OK	RF RX packet test with statistics stopped successfully.

SmartBond Production Line Tool

No.	Status	Description
110.	DUT_PDLL_PKT_RX_STATS_STOP_FAILED	RF RX packet test with statistics stop failed.
Production test – RX sensitivity test		
111.	DUT_BLE_TESTER_RX_TEST_PASSED	Bluetooth® LE tester RX sensitivity test passed.
112.	DUT_BLE_TESTER_RX_TEST_FAILED	Bluetooth® LE tester RX sensitivity test failed.
Production test – HCI error		
113.	DUT_PDLL_HCI_STANDARD_ERROR	An error occurred in HCI commands.
Production test - Golden Unit RSSI		
114.	DUT_PDLL_GU_RF_RX_TEST_PASSED	Golden Unit RF RX packet test passed.
115.	DUT_PDLL_GU_RF_RX_TEST_FAILED	Golden Unit RF RX packet test failed.
Production test - GPIO/LED test		
116.	DUT_PDLL_GPIO_TOGGLE_INIT	GPIO-LED test operation initialized.
117.	DUT_PDLL_GPIO_TOGGLE_START	GPIO-LED test operation start.
118.	DUT_PDLL_GPIO_TOGGLE_FINISHED_OK	GPIO-LED test operation completed successfully.
119.	DUT_PDLL_GPIO_TOGGLE_ERROR	GPIO-LED test operation error.
120.	DUT_PDLL_GPIO_TOGGLE_FAILED	GPIO-LED test operation failed.
121.	DUT_PDLL_GPIO_TOGGLE_PASSED	GPIO-LED test operation passed.
Production test – GPIO connection test		
122.	DUT_PDLL_GPIO_CONNECTION_INIT	GPIO connection test operation initialized.
123.	DUT_PDLL_GPIO_SET_START	GPIO connection test set operation start.
124.	DUT_PDLL_GPIO_SET_ERROR	GPIO connection test set operation error.
125.	DUT_PDLL_GPIO_SET_FINISHED_OK	GPIO connection test set operation success.
126.	DUT_PDLL_GPIO_GET_START	GPIO connection test get operation start.
127.	DUT_PDLL_GPIO_GET_ERROR	GPIO connection test get operation passed.
128.	DUT_PDLL_GPIO_GET_FINISHED_OK	GPIO connection test get operation success.
129.	DUT_PDLL_GPIO_CONNECTION_ERROR	GPIO connection test operation error.
130.	DUT_PDLL_GPIO_CONNECTION_FAILED	GPIO connection test operation failed.
131.	DUT_PDLL_GPIO_CONNECTION_PASSED	GPIO connection test operation completed successfully.
Production test - Sensor test		
132.	DUT_PDLL_SENSOR_TEST_INIT	Sensor test action initialized.
133.	DUT_PDLL_SENSOR_TEST_START	Sensor test action start.
134.	DUT_PDLL_SENSOR_TEST_OK	Sensor test action ended successfully.
135.	DUT_PDLL_SENSOR_TEST_FAILED	Sensor test action failed.
136.	DUT_PDLL_SENSOR_TEST_DATA_MATCH_OK	Sensor test action data matched.
137.	DUT_PDLL_SENSOR_TEST_DATA_MATCH_FAILED	Sensor test action data match failure.
Production test - Custom action test		

SmartBond Production Line Tool

No.	Status	Description
138.	DUT_PDLL_CUSTOM_ACTION_INIT	Custom test action initialized.
139.	DUT_PDLL_CUSTOM_ACTION_START	Custom test action start.
140.	DUT_PDLL_CUSTOM_ACTION_OK	Custom test action ended successfully.
141.	DUT_PDLL_CUSTOM_ACTION_FAILED	Custom test action failed.
142.	DUT_PDLL_CUSTOM_ACTION_DATA_MATCH_OK	Custom test action data matched.
143.	DUT_PDLL_CUSTOM_ACTION_DATA_MATCH_FAILED	Custom test action data match failure.
Production test – UART loop test		
144.	DUT_PDLL_UART_LOOP_INIT	UART loop test initialized.
145.	DUT_PDLL_UART_LOOP_START	UART loop test start.
146.	DUT_PDLL_UART_LOOP_OK	UART loop test ended successfully.
147.	DUT_PDLL_UART_LOOP_FAILED	UART loop test failed.
Production test – Sleep current measurement		
148.	DUT_SLEEP_CURRENT_MEASURE_INIT	Sleep current measurement test initialized.
149.	DUT_SLEEP_CURRENT_MEASURE_START	Sleep current measurement test started.
150.	DUT_SLEEP_DEVICE_SLEPT_OK	Sleep current measurement test, device went to sleep successfully.
151.	DUT_SLEEP_CURRENT_MEASURE_ERROR	Sleep current measurement test error.
152.	DUT_SLEEP_CURRENT_MEASURE_PASSED	Sleep current measurement test passed.
153.	DUT_SLEEP_CURRENT_MEASURE_FAILED	Sleep current measurement test failed.
Production test – Peripheral current measurement		
154.	DUT_PDLL_PERIPH_AMMETER_TEST_INIT	Peripheral current measurement test initialized.
155.	DUT_PDLL_PERIPH_AMMETER_TEST_START	Peripheral current measurement test started.
156.	DUT_PDLL_PERIPH_AMMETER_TEST_ERROR	Peripheral current measurement test error.
157.	DUT_PDLL_PERIPH_AMMETER_TEST_PASSED	Peripheral current measurement test passed.
158.	DUT_PDLL_PERIPH_AMMETER_TEST_FAILED	Peripheral current measurement test failed.
Memory programming - Generic errors		
159.	DUT_UDLL_SUCCESS	UDLL returned success.
160.	DUT_UDLL_ACTION_RESPONSE_ERROR	UDLL device responded with error.
161.	DUT_UDLL_UART_RX_TIMEOUT_ERROR	UDLL UART RX timeout. Cannot communicate with the DUT or DUT is not present.
162.	DUT_UDLL_NO_CRC_MATCH_ERROR	UDLL CRC match error.
163.	DUT_UDLL_PROG_PARAMS_ERROR	UDLL programming parameter error.
164.	DUT_UDLL_DEVICE_PARAMS_ERROR	UDLL device parameter error.
165.	DUT_UDLL_UART_WRITE_ERROR	UDLL UART write returned error.
166.	DUT_UDLL_UART_READ_ERROR	UDLL UART read returned error.
167.	DUT_UDLL_INTERNAL_ERROR	UDLL internal error.

SmartBond Production Line Tool

No.	Status	Description
168.	DUT_UDLL_COM_PORT_INIT_ERROR	UDLL COM port initialization error.
169.	DUT_UDLL_COM_PORT_ERROR	UDLL COM port error.
170.	DUT_UDLL_CANNOT_ALLOCATE_MEMORY	UDLL cannot allocate memory.
171.	DUT_UDLL_READ_FILE_SIZE_ERROR	UDLL read file size error.
172.	DUT_UDLL_CANNOT_OPEN_FW_FILE	UDLL cannot open firmware file.
173.	DUT_UDLL_CANNOT_OPEN_IMAGE_FILE	UDLL cannot open image file.
174.	DUT_UDLL_UART_PINS_PATCH_ERROR	UDLL cannot patch the UART pins into the firmware file.
175.	DUT_UDLL_INVALID_DBG_PARAMS	UDLL invalid debug library (dbg_dll.dll) parameters.
176.	DUT_UDLL_DBG_DLL_ERROR	UDLL debug library (dbg_dll.dll) access error.
Memory programming – QSPI memory initialization		
177.	DUT_UDLL_FLASH_INIT_INIT	QSPI initialization operation initialized.
178.	DUT_UDLL_FLASH_INIT_STARTED	QSPI initialization operation started.
179.	DUT_UDLL_FLASH_INIT_OK	QSPI initialization operation ended successfully.
180.	DUT_UDLL_FLASH_INIT_FAILED	QSPI initialization operation failed.
Memory programming – QSPI memory erase		
181.	DUT_UDLL_FLASH_ERASE_INIT	QSPI erase operation initialized.
182.	DUT_UDLL_FLASH_ERASE_STARTED	QSPI erase operation started.
183.	DUT_UDLL_FLASH_ERASE_OK	QSPI erase operation ended successfully.
184.	DUT_UDLL_FLASH_ERASE_FAILED	QSPI erase operation failed.
Memory programming - QSPI image write		
185.	DUT_UDLL_FLASH_IMG_WR_INIT	QSPI image write operation initialized.
186.	DUT_UDLL_FLASH_IMG_WR_STARTED	QSPI image write operation started.
187.	DUT_UDLL_FLASH_IMG_WR_OK	QSPI image write operation ended successfully.
188.	DUT_UDLL_FLASH_IMG_WR_FAILED	QSPI image write operation failed.
Memory programming - Configuration script write		
189.	DUT_UDLL_CS_WRITE_INIT	CS field write operation initialized.
190.	DUT_UDLL_CS_WRITE_STARTED	CS field write operation started.
191.	DUT_UDLL_CS_WRITE_NUM_OF_ENTRIES	CS update the number of fields to be burned.
192.	DUT_UDLL_CS_WRITE_STATUS	CS field write progress status update
193.	DUT_UDLL_CS_WRITE_RDBK_STARTED	CS readback process started.
194.	DUT_UDLL_CS_WRITE_RDBK_STATUS	CS readback progress status update
195.	DUT_UDLL_CS_WRITE_OK	CS write ended successfully.
196.	DUT_UDLL_CS_WRITE_FAILED	CS write failed.
Memory programming - Memory write operation		
197.	DUT_UDLL_MEM_DATA_WR_INIT	Custom memory data burn operation started.
198.	DUT_UDLL_MEM_DATA_WR_INIT	Custom memory data burn operation started.

SmartBond Production Line Tool

No.	Status	Description
199.	DUT_UDLL_MEM_DATA_WR_STARTED	Custom memory data burn update interim status.
200.	DUT_UDLL_MEM_DATA_WR_OK	Custom memory data burn operation ended successfully.
201.	DUT_UDLL_MEM_DATA_WR_FAILED	Custom memory data burn operation failed.
Memory programming - Memory read operation		
202.	DUT_UDLL_MEM_RD_INIT	Memory read operation initialized.
203.	DUT_UDLL_MEM_RD_STARTED	Memory read operation started.
204.	DUT_UDLL_MEM_RD_OK	Memory read operation ended successfully.
205.	DUT_UDLL_MEM_RD_FAILED	Memory read operation failed.
Production tests – Scan test		
206.	DUT_PDLL_BLE_SCAN_INIT	Scan test initialize.
207.	DUT_PDLL_BLE_SCAN_START	Scan test started.
208.	DUT_PDLL_BLE_SCAN_NOT_YET_FOUND	Scan test, DUT not yet found.
209.	DUT_PDLL_BLE_SCAN_FOUND	Scan test, DUT found.
210.	DUT_PDLL_BLE_SCAN_RSSI_FAILED	Scan test, DUT found but RSSI failed.
211.	DUT_PDLL_BLE_SCAN_FAILED	Scan test failed. DUT not found.
Generic		
212.	DUT_GU_ERROR	GU has error
213.	INVALID_DUT_RES	Invalid DUT status result.

Appendix R Golden Unit Status Codes

Table 79 contains all the possible status codes the Golden Unit can have, followed by a brief description. The table categorizes the status based on the various states the Golden Unit may be during testing and programming the DUTs.

Table 79. Golden Unit status codes

No.	Status	Description
	Generic	
	GU_NOT_ACTIVE	GU is not active.
1.	GU_INTERNAL_SYSTEM_ERROR	GU internal system error.
2.	GU_COM_OPEN_OK	GU COM port opened successfully.
3.	GU_COM_OPEN_FAILED	GU COM port failed to open.
4.	GU_RESET_START	GU reset started.
5.	GU_RESET_OK	GU reset successfully.
6.	GU_RESET_FAILED	GU reset failed.
7.	GU_PDLL_NO_ERROR	PDLL returned success.
8.	GU_PDLL_PARAMS_ERROR	GU PDLL parameters have errors.
9.	GU_PDLL_RX_TIMEOUT	GU did not reply on a PDLL message request.
10.	GU_PDLL_TX_TIMEOUT	GU TX timeout when sending a message to CPLD.
11.	GU_PDLL_UNEXPECTED_EVENT	Received an unexpected message from the GU.
12.	GU_PDLL_CANNOT_ALLOCATE_MEMORY	PDLL cannot allocate memory.
13.	GU_PDLL_INTERNAL_ERROR	PDLL internal system error.
14.	GU_PDLL_THREAD_CREATION_ERROR	PDLL thread creation error.
15.	GU_PDLL_DBG_DLL_ERROR	PDLL debug library (dbg_dll.dll) access error.
16.	GU_PDLL_INVALID_DBG_PARAMS	PDLL invalid debug library (dbg_dll.dll) parameters.
	GU COM port handling	
17.	GU_PDLL_COM_PORT_INIT	GU COM port open initialized.
18.	GU_PDLL_COM_PORT_START	GU COM port open started.
19.	GU_PDLL_COM_PORT_OK	GU COM port opened OK.
20.	GU_PDLL_COM_PORT_FAILED	GU COM port FAILED.
	GU firmware version	
21.	GU_PDLL_FW_VERSION_GET_START	GU PDLL firmware version acquisition started.
22.	GU_PDLL_FW_VERSION_GET_OK	GU PDLL firmware version acquisition OK.
23.	GU_PDLL_FW_VERSION_GET_FAILED	GU PDLL firmware version acquisition FAILED.
24.	GU_PDLL_FW_VERSION_VALID	GU firmware version is valid.
25.	GU_PDLL_FW_VERSION_NOT_VALID	GU firmware version is not valid. Upgrade is needed.
	GU CPLD control	
26.	GU_PDLL_RDTESTER_INIT	PLT hardware tester initializing.
27.	GU_PDLL_RDTESTER_INIT_START	PLT hardware tester initialize started.

SmartBond Production Line Tool

No.	Status	Description
28.	GU_PDLL_RDTESTER_INIT_OK	PLT hardware tester initialized successful.
29.	GU_PDLL_RDTESTER_INIT_FAILED	PLT hardware tester initialization failed.
30.	GU_PDLL_RDTESTER_UART_CONNECT_INIT	PLT hardware tester UART connection initialized.
31.	GU_PDLL_RDTESTER_UART_CONNECT_START	PLT hardware tester UART connection started.
32.	GU_PDLL_RDTESTER_UART_CONNECT_OK	PLT hardware tester UART connected successfully.
33.	GU_PDLL_RDTESTER_UART_CONNECT_FAILED	PLT hardware tester UART connection failed.
34.	GU_PDLL_RDTESTER_UART_LOOPBACK_INIT	PLT hardware tester UART loopback process initialized.
35.	GU_PDLL_RDTESTER_UART_LOOPBACK_START	PLT hardware tester UART loopback process started.
36.	GU_PDLL_RDTESTER_UART_LOOPBACK_OK	PLT hardware tester UART loopback process success.
37.	GU_PDLL_RDTESTER_UART_LOOPBACK_FAILED	PLT hardware tester UART loopback process failed.
38.	GU_PDLL_RDTESTER_VBAT_UART_CNTRL_INIT	PLT hardware tester VBAT/UART control initialized.
39.	GU_PDLL_RDTESTER_VBAT_UART_CNTRL_START	PLT hardware tester VBAT/UART control started.
40.	GU_PDLL_RDTESTER_VBAT_UART_CNTRL_OK	PLT hardware tester VBAT/UART control success.
41.	GU_PDLL_RDTESTER_VBAT_UART_CNTRL_FAILED	PLT hardware tester VBAT/UART control failed.
42.	GU_PDLL_RDTESTER_VBAT_UART_RST_CNTRL_INIT	PLT hardware tester VBAT/UART/Reset control initialized.
43.	GU_PDLL_RDTESTER_VBAT_UART_RST_CNTRL_START	PLT hardware tester VBAT/UART/Reset control started.
44.	GU_PDLL_RDTESTER_VBAT_UART_RST_CNTRL_OK	PLT hardware tester VBAT/UART/Reset control success.
45.	GU_PDLL_RDTESTER_VBAT_UART_RST_CNTRL_FAILED	PLT hardware tester VBAT/UART/Reset control failed.
46.	GU_PDLL_RDTESTER_VPP_CNTRL_INIT	PLT hardware tester VPP control initialized.
47.	GU_PDLL_RDTESTER_VPP_CNTRL_START	PLT hardware tester VPP control started.
48.	GU_PDLL_RDTESTER_VPP_CNTRL_OK	PLT hardware tester VPP control success.
49.	GU_PDLL_RDTESTER_VPP_CNTRL_FAILED	PLT hardware tester VPP control failed.
50.	GU_PDLL_RDTESTER_RST_PULSE_INIT	PLT hardware tester Reset pulse control initialized.
51.	GU_PDLL_RDTESTER_RST_PULSE_START	PLT hardware tester Reset pulse control started.
52.	GU_PDLL_RDTESTER_RST_PULSE_OK	PLT hardware tester Reset pulse control success.
53.	GU_PDLL_RDTESTER_RST_PULSE_FAILED	PLT hardware tester Reset pulse control failed.
54.	GU_PDLL_RDTESTER_UART_PULSE_INIT	PLT hardware tester XTAL trim pulse in UART TX pin initialized.
55.	GU_PDLL_RDTESTER_UART_PULSE_START	PLT hardware tester XTAL trim pulse in UART TX pin started.
56.	GU_PDLL_RDTESTER_UART_PULSE_OK	PLT hardware tester XTAL trim pulse in UART TX pin success.

SmartBond Production Line Tool

No.	Status	Description
57.	GU_PDLL_RDTESTER_UART_PULSE_FAILED	PLT hardware tester XTAL trim pulse in UART TX pin failed.
58.	GU_PDLL_RDTESTER_XTAL_PULSE_INIT	PLT hardware tester XTAL trim pulse in GATE pin initialized.
59.	GU_PDLL_RDTESTER_XTAL_PULSE_START	PLT hardware tester XTAL trim pulse in GATE pin started.
60.	GU_PDLL_RDTESTER_XTAL_PULSE_OK	PLT hardware tester XTAL trim pulse in GATE pin success.
61.	GU_PDLL_RDTESTER_XTAL_PULSE_FAILED	PLT hardware tester XTAL trim pulse in GATE pin failed.
62.	GU_PDLL_RDTESTER_PULSE_WIDTH_INIT	PLT hardware tester pulse width initialized.
63.	GU_PDLL_RDTESTER_PULSE_WIDTH_START	PLT hardware tester pulse width started.
64.	GU_PDLL_RDTESTER_PULSE_WIDTH_OK	PLT hardware tester pulse width success.
65.	GU_PDLL_RDTESTER_PULSE_WIDTH_FAILED	PLT hardware tester pulse width failed.
66.	GU_PDLL_RDTESTER_VBAT_CNTRL_INIT	PLT hardware tester VBAT control initialized.
67.	GU_PDLL_RDTESTER_VBAT_CNTRL_START	PLT hardware tester VBAT control started.
68.	GU_PDLL_RDTESTER_VBAT_CNTRL_OK	PLT hardware tester VBAT control success.
69.	GU_PDLL_RDTESTER_VBAT_CNTRL_FAILED	PLT hardware tester VBAT control failed.
70.	GU_PDLL_RDTESTER_INVALID_COMMAND	PLT hardware tester unknown command.
GU RF packet TX for DUT RSSI RF test		
71.	GU_PDLL_PKT_TX_START_INIT	GU RF packet TX initialized.
72.	GU_PDLL_PKT_TX_START	GU RF packet TX started.
73.	GU_PDLL_PKT_TX_STARTED_OK	GU RF packet TX success.
74.	GU_PDLL_PKT_TX_STARTED_FAILED	GU RF packet TX failed.
75.	GU_PDLL_PKT_TX_ENDED_OK	GU RF packet TX ended successfully.
76.	GU_PDLL_PKT_TX_ENDED_FAILED	GU RF packet TX ended failed.
GU GPIO toggling for sanity test		
77.	GU_PDLL_GPIO_TOGGLE_INIT	GU GPIO toggle operation initialized.
78.	GU_PDLL_GPIO_TOGGLE_START	GU GPIO toggle operation start.
79.	GU_PDLL_GPIO_TOGGLE_FINISHED_OK	GU GPIO toggle operation completed successfully.
80.	GU_PDLL_GPIO_TOGGLE_FAILED	GU GPIO toggle operation failed.
GU Bluetooth® LE advertising scan test		
81.	GU_PDLL_BLE_SCAN_INIT	GU scan operation initialized.
82.	GU_PDLL_BLE_SCAN_START	GU scan operation started.
83.	GU_PDLL_BLE_SCAN_RESET	GU scan operation reset.
84.	GU_PDLL_BLE_SCAN_RETRY	GU scan operation retry.
85.	GU_PDLL_BLE_SCAN_OK	GU scan operation completed successfully.
86.	GU_PDLL_BLE_SCAN_FAILED	GU scan operation failed.
General		

SmartBond Production Line Tool

No.	Status	Description
87.	GU_PDLL_HCI_STANDARD_ERROR	HCI communication error.
88.	GU_ALL_DUT_FAILED	All DUTs failed.
89.	INVALID_GU_RES	Invalid GU status result.

Revision History

Revision	Date	Description
1.0	Mar 6, 2024	Initial version.

SmartBond Production Line Tool

Status Definitions

Status	Definition
DRAFT	The content of this document is under review and subject to formal approval, which may result in modifications or additions.
APPROVED or unmarked	The content of this document has been approved for publication.

RoHS Compliance

Renesas' suppliers certify that its products are in compliance with the requirements of Directive 2011/65/EU of the European Parliament on the restriction of the use of certain hazardous substances in electrical and electronic equipment. RoHS certificates from our suppliers are available on request.