

User Manual

DA9070 / DA9231 Fuel Gauge Development Kit

UM-PM-039

Abstract

This document describes the hardware in the DA9070 / DA9231 Fuel Gauge Evaluation and Development Kit.

Contents

Abstract	1
Contents	2
Figures.....	3
Tables	3
Terms and Definitions.....	3
References	3
Introduction.....	4
Default Settings	4
Board overview.....	5
Key Features	5
System Diagram	6
Chip Evaluation Mode.....	7
Evaluation Mode Basic Set-up	7
DA9070 Evaluation	9
Recommended Operating Conditions	10
Connectors for DA9070 Evaluation	10
GUI Features	12
Charging and Discharging.....	12
Applying external loads to LDO and Boost outputs	12
DA9231 Evaluation	14
Recommended Operating Conditions	14
Connectors for DA9231 Evaluation	15
Battery Profile Mode.....	16
Revision History	18

Figures

Figure 1: DA9070 Fuel Gauge EVK Board Top View	5
Figure 2: DA9070 Fuel Gauge EVK System Diagram	6
Figure 3: Basic Jumper Settings for Evaluation Mode	7
Figure 4: GUI for DA9070 Fuel Gauge EVK.....	8
Figure 5: DA9070 Typical Application Diagram.....	9
Figure 6: Fuel Gauge and Load Profile Window	12
Figure 7: Applying External Loads	13
Figure 8: DA9231 Typical Application Diagram.....	14
Figure 9: Jumper Settings for Battery Profile Mode	16
Figure 10: PPM windows.....	17

Tables

Table 1: Recommended Operation Conditions	10
Table 2: DA9070 Input and Output Connectors	10
Table 3: Default Load Resistor Values	13
Table 4: Recommended Operation Conditions	14
Table 5: DA9231 Input and Output Connectors	15

Terms and Definitions

SOC	State of Charge
VBAT	Voltage of Battery
IBAT	Current of Battery
FG	Fuel Gauge
ADC	Analog to Digital Converter
MCU	Micro-Controller Unit
UART	Universal Asynchronous Receiver-Transmitter
USB	Universal Serial Bus
PMIC	Power Management IC
GUI	Graphic User Interface
EVK	Evaluation Kit
PCB	Print Circuit Board

References

- [1] DA9070 Datasheet
- [2] DA9231 Datasheet
- [3] Application Note: AN-SW-121_DA9070 Power Profile Manager and SOCF
- [4] Schematic: DA9070_FG_EVAL_v3_schematic.pdf
- [5] PCB Layout: DA9070_FG_EVAL_v3_pcb.pdf
- [6] Bill of Materials: DA9070_EVAL_BOARD_REV3_BOM.pdf

Introduction

DA9070 Fuel Gauge EVK is a fuel gauge development and evaluation platform to demonstrate a low power fuel gauge system using the DA9070, DA9231, and an MCU with Dialog's proprietary algorithm. The DA9070 is an ultra-low quiescent current PMIC with integrated charger, buck converter, boost converter, and 3 LDOs. The DA9231 is an ultra-low quiescent current buck converter that is efficient down to 10 μ A with a nano-ampere LDO.

The low-power consumption MCU (STM32L151RD) allows the user to program the battery charging profile, discharge load profile, and fuel gauge algorithm. The DA9070 Fuel Gauge EVK can also be used as an evaluation board for both the DA9070 and DA9231.

This document describes the system diagram, the various functional sections on the EVK board, and board set-up for chip evaluation and fuel gauge development.

Two GUIs are provided with the DA9070 Fuel Gauge EVK:

- 1) The DA9070 Fuel Gauge EVK, SmartCanvas GUI, communicates with both the DA9070 and the DA9231. It also has a fuel gauge display and can control the on-board loads. This GUI is used for evaluation purposes.
- 2) The Power Profile Manager (PPM). This GUI generates or loads battery profile data and runs the fuel gauge performance test. This GUI is used to develop a software fuel gauge based on the user's battery.

Default Settings

The DA9070 settings are loaded from the on-board MCU at startup, including charge current and voltage settings:

Buck output: 2.0V, enabled

In the default configuration, the buck output voltage powers the MCU. If a different output voltage is required, change the J24 position to 3.3V. This allows the Buck voltage to be modified as needed. However, the GUI fuel gauge function will not be accurate in this configuration.

Boost output: 12V, disabled

Charge current: 40mA

Charge voltage: 4.2V

LDO outputs:

All LDO voltages are set to 0.8V initially, but the voltage may change if load settings are changed in the GUI load profile tool. If the load profile tool is not used, LDO output settings may be changed manually in the GUI.

Battery Information:

The battery profile for the included 80mAh battery is pre-loaded in the MCU. This includes capacity, charge current, state of charge (SOC) lookup table, and other data. The pre-set battery data can only be changed by first running the Power Profile Manager software.

A battery other than the one included can be used for evaluation without changing the profile. However, charging settings must be changed manually in the GUI.

Also, the GUI based fuel gauge will not be accurate unless a new profile is updated and saved to the MCU.

Refer to AN-SW-121 for details about the battery profiling procedure.

Board overview

The whole system is designed to demonstrate the charge and discharge of a single lithium-polymer battery, and the SOC (state-of-charge) prediction via fuel gauging. It also enables customer to do independent evaluation on both DA9070 and DA9231 ICs. Figure 1 shows the top view of DA9070 Fuel gauge EVK board and highlights the function of each section.

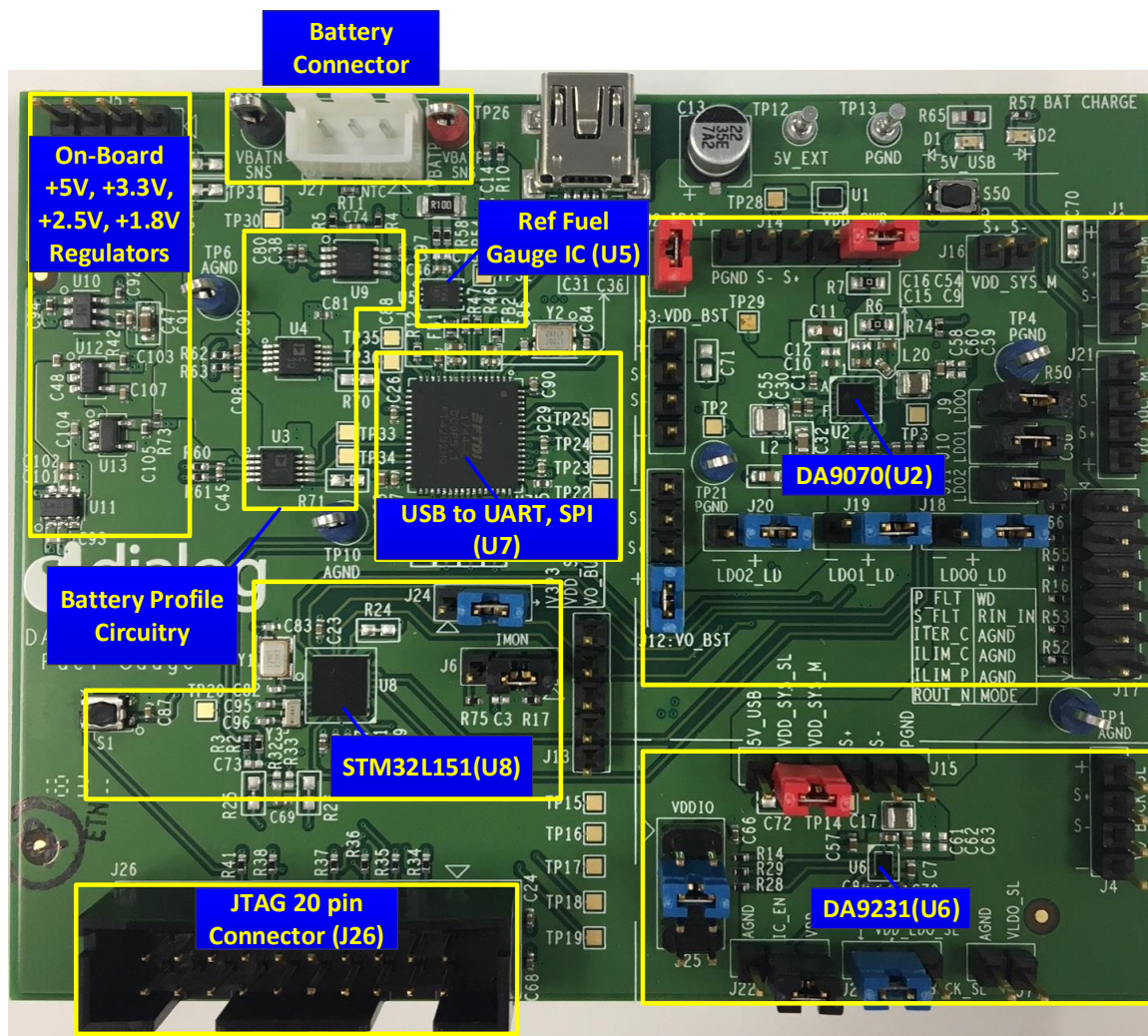

Figure 1: DA9070 Fuel Gauge EVK Board Top View

Key Features

- Single USB connector supports both charging power and communication with PC
- Support STM32L151 MCU firmware update through JTAG 20 pin connector
- Two configurable modes through jumper: Chip evaluation mode; Battery Profile Mode including Fuel Gauge Performance Test
- Supports register read/write in chip evaluation mode with Dialog's SmartCanvas GUI
- Supports battery characterization with real-time voltage and charge/discharge current measurement which can be monitored with Dialog's Power Profile Manager (PPM) on PC
- Supports on-board customized load-profile programming
- Supports a performance comparison between Dialog's low-power software fuel gauge solution and a reference Coulomb-counter based fuel gauge IC

System Diagram

Figure 2 shows the DA9070 fuel gauge EVK system diagram. The whole system includes the following major portions:

- DA9070: Dialog nano-power battery charge management PMIC with Fuel Gauge
- DA9231: Dialog nano-power PMIC
- STM32L151 MCU: For implementing fuel gauge SOC algorithm
- FTDI: Communication interface-bridge between USB and UART, SPI ports
- JTAG: Communication port for STM32L151 MCU firmware update
- LTC2941: Reference Coulomb-count based fuel gauge IC
- Battery V&I Monitor: Circuitry to monitor battery voltage & current in real-time. For battery profiling
- System Load Model: A set of on-board resistors with ON/OFF control issued by MCU to mimic various load patterns in real applications
- PC GUI: Software on PC. For chip evaluation. Both registers of DA9070 and DA9231 can be read or written through GUI
- PC PPM: Software on PC. For battery profiling and fuel gauge performance test
- BAT: Single lithium-poly battery. Support up to 500mAh

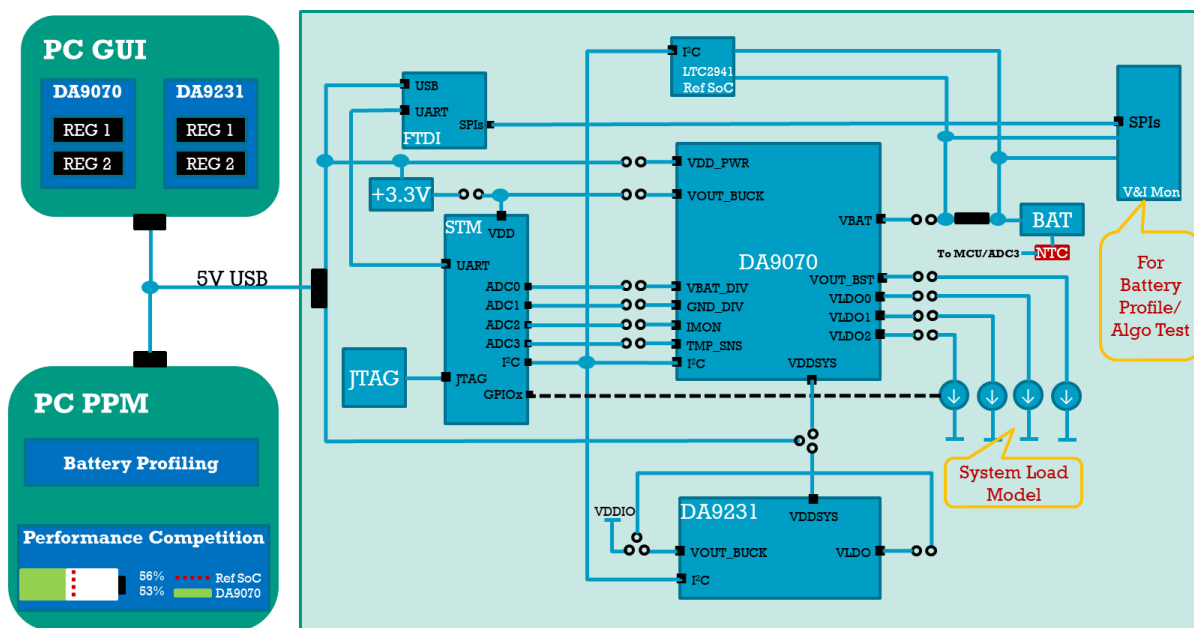

Figure 2: DA9070 Fuel Gauge EVK System Diagram

Chip Evaluation Mode

DA9070 Fuel gauge EVK is able to be configured to perform chip evaluations with or without battery. For example, DA9070 or DA9231 can be evaluated for current consumption, efficiency, load/line regulation, load/line transient etc. without battery; DA9070 can also be evaluated for sequence, system load transient while the battery being plugged-in.

Evaluation Mode Basic Set-up

It is recommended to follow the following steps while setting up the chip evaluation mode.

- Install jumpers as shown in [Figure 3](#).

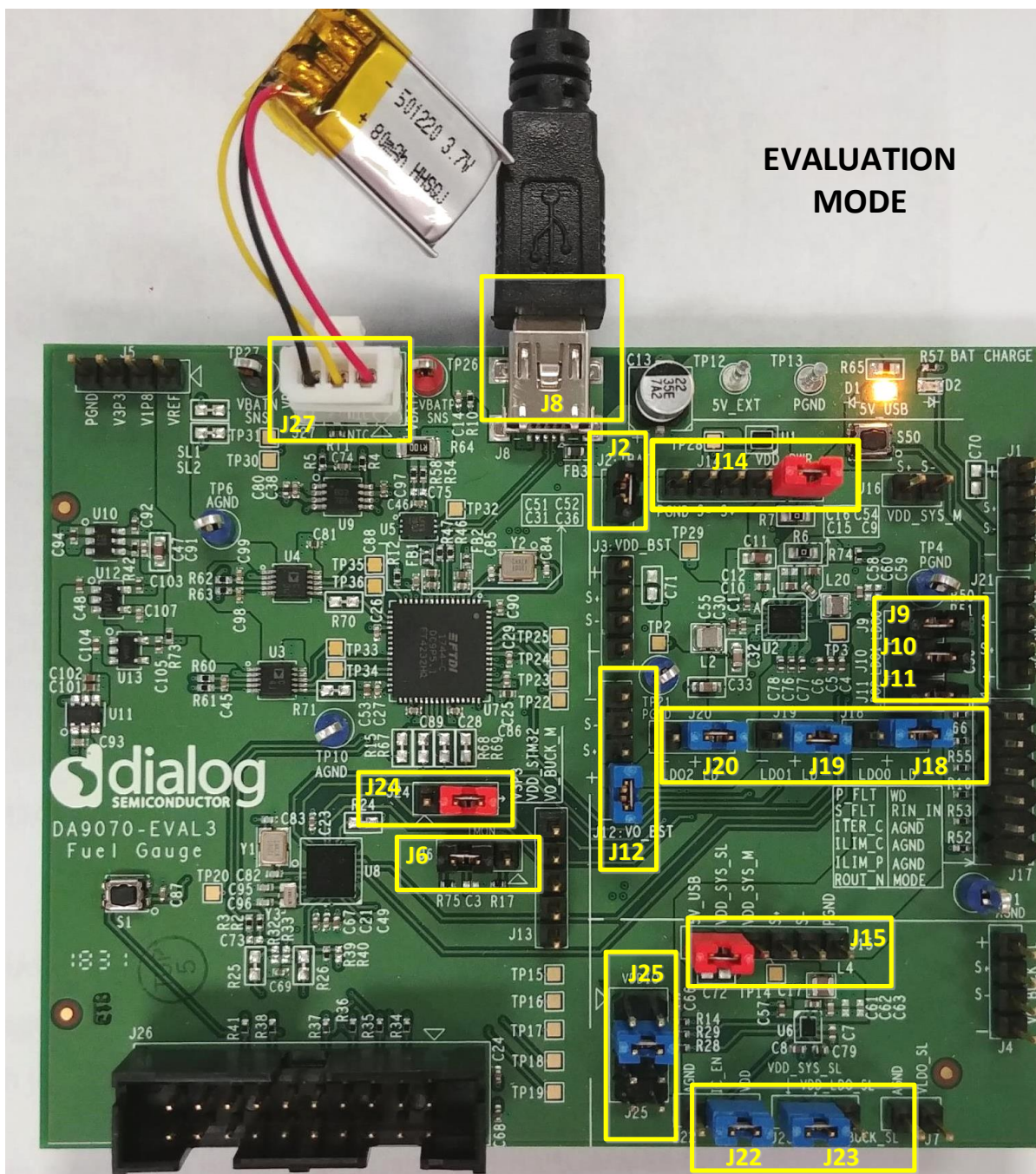

Figure 3: Basic Jumper Settings for Evaluation Mode

- The boxed jumpers must be installed in designated positions in order to evaluate both DA9070 and DA9231. If only evaluate DA9070, change J22 jumper to IC_EN=AGND so DA9231 is disabled; If only evaluate DA9231, remove J14 jumper so DA9070 is disabled.

- Connect the battery to J27. The positive terminal is labeled VBAT_P, adjacent to the red test point TP26

- Plug in a USB cable into J8 connector. Connect the USB cable to either a traveler adapter or a PC. The Yellow LED light is ON which means the EVK board is powered. By default, both DA9070 and DA9231 are OTP programmed to start up automatically as soon as the EVK board is powered.

- If the USB cable is connected to a PC, open the "DA9070 Fuel Gauge EVK" GUI that was installed on the PC. Start to configure device registers as well as read device status using GUI, as shown in Figure 4.

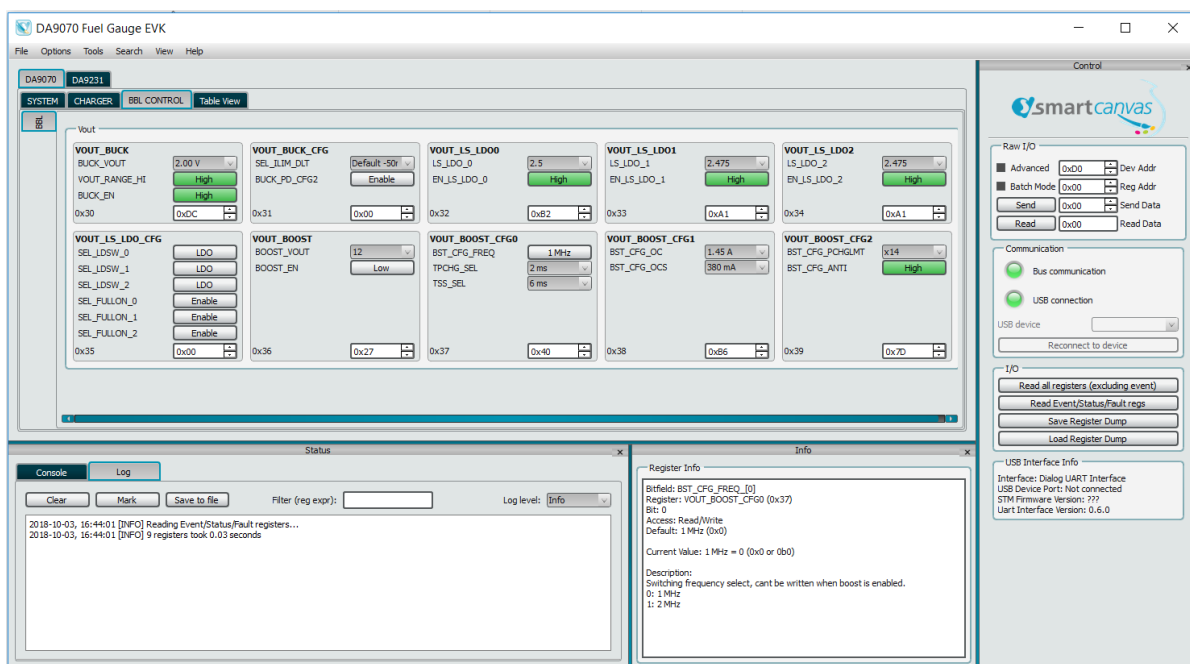

Figure 4: GUI for DA9070 Fuel Gauge EVK

DA9070 Evaluation

The typical application diagram of DA9070 is shown in Figure 5.

DA9070 includes a Buck regulator, a Boost Regulator, 3x LDO/LDSW, and a linear battery charger.

On DA9070 Fuel gauge EVK, each regulator can be evaluated individually. It is recommended to follow the operation conditions as shown in Table 1 to avoid any damage to the EVK board. For test and measurement set-up, please refer to Table 2 for descriptions of connectors on the EVK board.

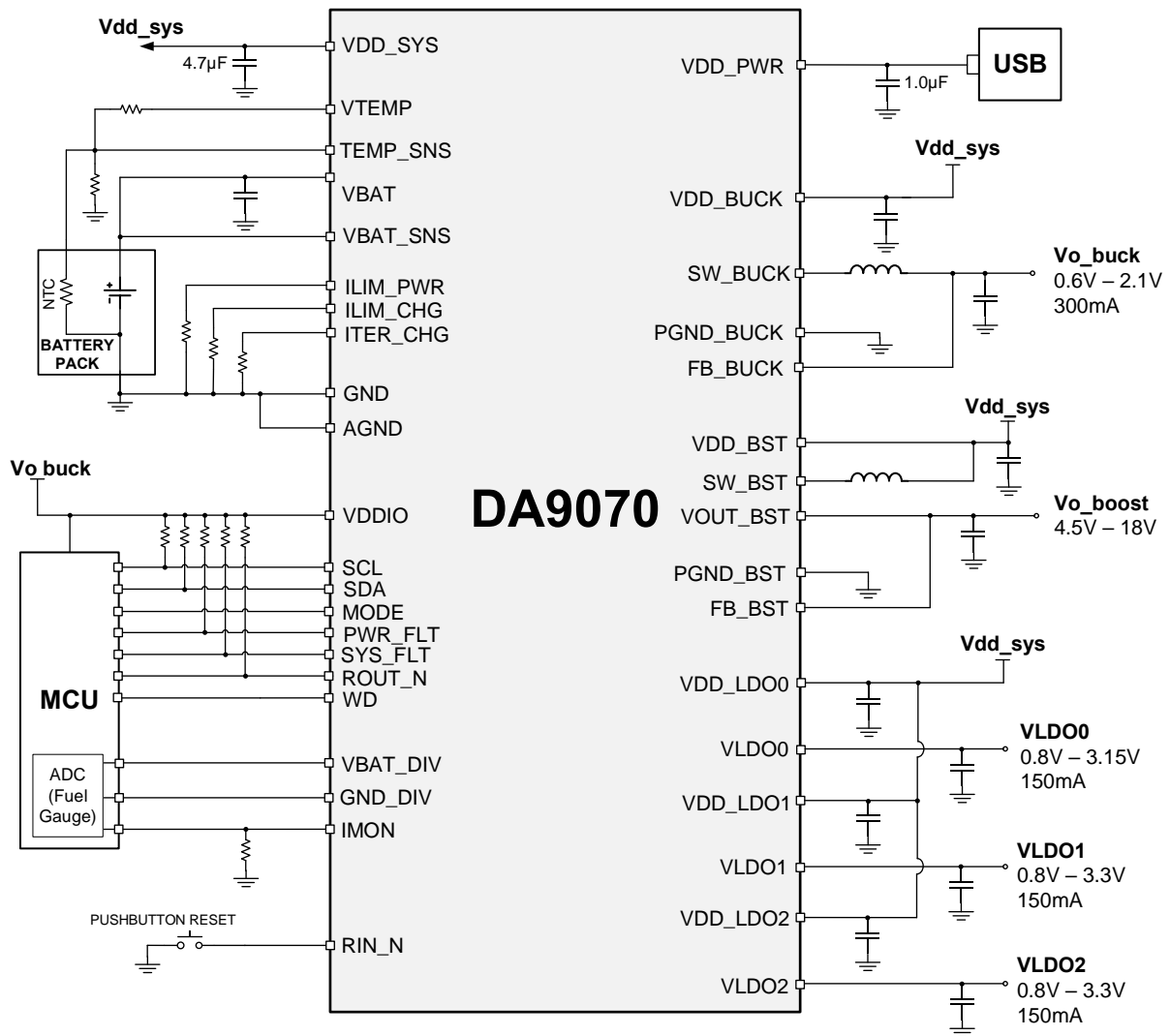

Figure 5: DA9070 Typical Application Diagram

Recommended Operating Conditions

Table 1: Recommended Operation Conditions

Parameter	Description	Conditions	Min	Typ	Max	Unit
VDD_PWR	VDD_PWR voltage	Including OVP range	3.6	5	20	V
	VDD_PWR operating voltage		3.6	5	5.5	V
VBAT	Battery voltage	VDD_PWR supplied	0	3.7	4.7	V
	Battery voltage	VDD_PWR not supplied	2.8	3.7	4.7	V
VDD_LDO	VDD_LDO voltage	Load switch mode	0.8		5.5	V
		LDO mode	1.8		5.5	V
VDDIO	IO voltage	VDDIO < VDD_PWR or VBAT, whichever is greater	1.4	1.8	3.3	V
I_PWR	VDD_PWR current				500	mA
I_BAT	Battery discharge				800	mA
I_SYS	VDD_SYS current				800	mA
I_LDO	LDO output current				150	mA
I_BUCK	Buck output current				300	mA
I_BOOST	Boost output current	12Vout, 2.7VBAT			100	mA

Connectors for DA9070 Evaluation

Table 2: DA9070 Input and Output Connectors

Connectors	Pin Names	Descriptions
J1 (VDD_BUCK_M)	+ / S+ / S- / -	+ and - are terminals for connecting an external load to the DA9070 VDD_SYS; S+ and S- are kelvin sense points for DA9070 Buck input. For input voltage measurement during efficiency test, S+ and S- should connect to multi-meter for better accuracy.
J2 (IBAT)		Install J2 jumper will connect the VBAT pin of DA9070 to battery positive terminal VBAT_P through current sense shunt resistor. It also enables battery current monitoring using external current probe.
J3 (VDD_BST)	+ / S+ / S- / -	+ and - are terminals for connecting external power supply to the Boost input; S+ and S- are kelvin sense points for the Boost input. For input voltage measurement during efficiency test, S+ and S- should connect to multi-meter for better accuracy.
J6 (IMON)		Install J6 jumper will connect the IMON pin of DA9070 to STM32L151(U8) ADC input. It also enables IMON current measurement using external multi-meter. Position 2-3 should be used.
J9 (LDO_0)	VDD_LDO0/ VDD_SYS_M	Install J9 jumper will connect LDO_0 input (VDD_LDO0) to VDD_SYS_M of DA9070.
J10	VDD_LDO1/	Install J10 jumper will connect LDO_1 input

(LDO_1)	VDD_SYS_M	(VDD_LDO1) to VDD_SYS_M of DA9070.
J11 (LDO_2)	VDD_LDO2/ VDD_SYS_M	Install J11 jumper will connect LDO_2 input (VDD_LDO2) to VDD_SYS_M of DA9070.
J12 (VO_BST)	BST_LD/ +/ S+/ S- / -	+ and - are terminals for connecting external load to the Boost output; When BST_LD (pin 1) is short to + pin on J12, the on-board load resistor will be used as the Boost output load. S+ and S- are kelvin sense points for the Boost output. For output voltage measurement during efficiency test, S+ and S- should connect to multi-meter for better accuracy.
J13	VBAT_DIV/ GND_DIV/ I_MON/ TMP_SNS/ AGND	Sense points. For probe only.
J14	SW_BYPASS/ VDD_PWR/ SW_USE/ S+/ S- / PGND	DA9070 power input (VDD_PWR) supply selection and voltage sense. VDD_PWR can directly connect to the 5V_USB rail by shorting J14 pin-1 to pin-2; VDD_PWR can also connect to the 5V_USB rail though load switch U1 by shorting J14 pin-2 to pin-3. The load switch is controlled by the MCU during battery profiling. For evaluation use jumper positions 1 and 2. J14-S+ and J14-S- pins are kelvin sense points of DA9070 input VDD_PWR.
J16 (VDD_SYS_M)	S+ / S-	S+ and S- are kelvin sense points for DA9070 VDD_SYS.
J17	P_FLT, WD, S_FLT, RIN_N, ITER_C, AGND, ILIM_C, AGND, ILIM_P, AGND, ROUT_N, MODE	Sense points. For probe only.
J18 (LDO0_LD)	LDO0_LD/ +/ -	+ and - are terminals for connecting an external load to DA9070 LDO0 output; When pin-1 is shorted to the + pin on J18, the on-board load resistor will be used as the LDO0 output load.
J19 (LDO1_LD)	LDO1_LD/ +/ -	+ and - are terminals for connecting external load to DA9070 LDO1 output; When pin-1 is shorted to + pin on J19, the on-board load resistor will be used as the LDO1 output load.
J20 (LDO2_LD)	LDO2_LD/ +/ -	+ and - are terminals for connecting external load to DA9070 LDO2 output; When pin-1 is shorted to + pin on J20, the on-board load resistor will be used as the LDO2 output load.
J21 (VO_BUCK_M)	+/ S+/ S- / -	+ and - are terminals for connecting an external load to DA9070 Buck output; S+ and S- are kelvin sense points for DA9070 Buck output. For output voltage measurement during efficiency test, S+ and S- should connect to multi-meter for better accuracy.

GUI Features

All DA9070 and DA9231 registers are accessible via the DA9070 Fuel Gauge EVK GUI.

The GUI also includes a fuel gauge function and on-board load control. These are shown in Figure 6.

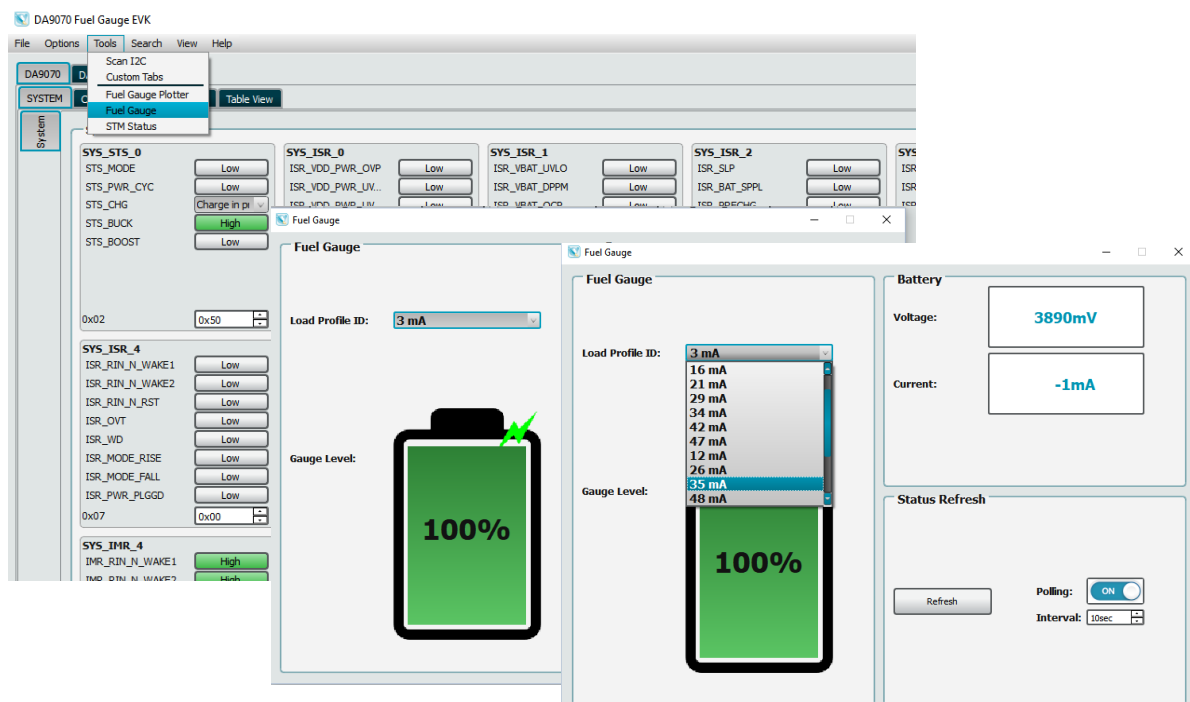

Figure 6: Fuel Gauge and Load Profile Window

Note that the load values in the pull-down menu are based on the default resistor values in Table 3. The minimum value of 3mA is the MCU's typical standby current.

The fuel gauge displays the real time battery voltage, discharge current, and State-of-Charge based on the battery profile stored in the MCU. Be sure to update this profile if a different battery is used. The fuel gauge will display the correct state of charge regardless of whether the on-board or external loads are used. Charge current is not displayed and can be assumed to be the set charge current; either set by the MCU at the pre-loaded value or by I2C command through the GUI.

The DA9070 fuel gauge outputs (IMON and VBAT_DIV) are directly controlled by the MCU. These registers should not be controlled by the user.

Charging and Discharging

Battery charging is enabled by default. To stop battery charging, simply remove the jumper at J14. This will remove VDD_PWR from the DA9070 and is the only method recognized by the MCU and fuel gauge. Charging can also be enabled and disabled using I2C command or with the MODE pin. When the battery is fully charged, the DA9070 will stop charging and restart only when the battery voltage has dropped to the re-charge threshold.

Applying external loads to LDO and Boost outputs

For the three LDO rails as well as the Boost rail in DA9070, the DA9070 Fuel gauge EVK has the flexibility to use either on-board load resistors or connect to external loads.

If on-board load resistors are used, jumpers need to be installed on LDO0/1/2_LD and VO_BST connectors, as shown in Figure 3. The default load resistor values are shown in Table 3. The load current for each rail will be determined by the programmed output voltage divided by the fixed load resistor values. The total load can be controlled from the GUI Fuel Gauge window.

Table 3: Default Load Resistor Values

Designator	Description	Value
R72	Load resistor for LDO0 rail	30.9Ω, 1/2W
R9	Load resistor for LDO1 rail	62Ω, 1/4W
R11	Load resistor for LDO2 rail	154Ω, 1/8W
R8	Load resistor for Boost rail	3.3kΩ, 1/8W

If an external load needs to be applied to any rail, first remove the jumper previously installed on LDO0/1/2_LD or VO_BST connector. Then apply the external load between '+' and '-' terminals of LDO0/1/2_LD or VO_BST connector, as shown in Figure 7.

Make sure the load current always flows out of '+' terminal and flows into '-' terminal on the connectors.

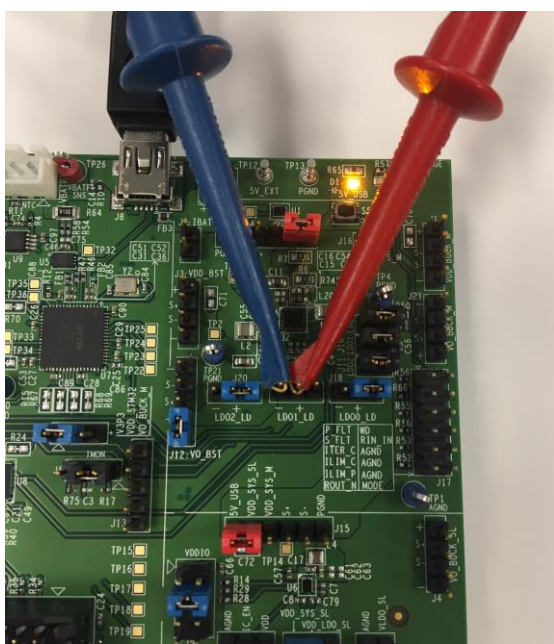

LDO1 output

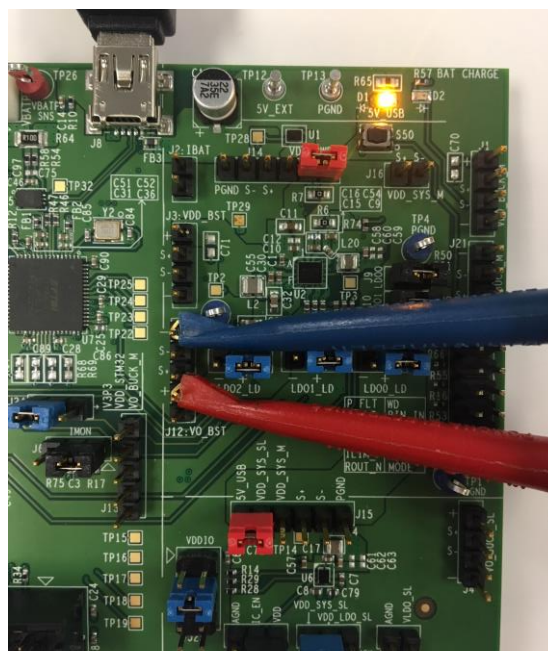

Boost output

Figure 7: Applying External Loads

DA9231 Evaluation

The typical application diagram of DA9231 is shown in Figure 8.

DA9231 includes a Buck regulator and an LDO. On the DA9070 Fuel gauge EVK, both the Buck and LDO regulators can be evaluated individually. It is recommended to follow the operation conditions as shown in Table 4 to avoid any damage to the EVK board. For test and measurement set-up, please refer to Table 5 for descriptions of connectors on the EVK board.

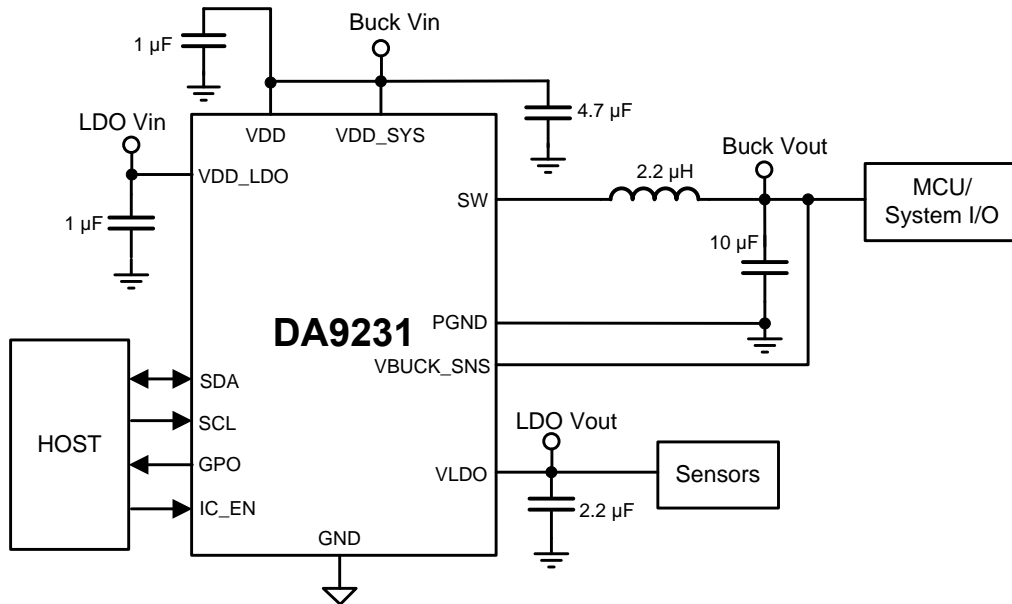

Figure 8: DA9231 Typical Application Diagram

Recommended Operating Conditions

Table 4: Recommended Operation Conditions

Parameter	Description	Conditions	Min	Typ	Max	Unit
VDD	Analog Input	VDD= VDD_SYS	2.5		5.5	V
VDD_SYS	Power Input	VDD= VDD_SYS	2.5		5.5	V
VDD_LDO	LDO mode		1.8		5.5	V
	Load Switch mode		0.8		5.5	V
I_BUCK	Buck Output Current				300	mA
I_LDO	LDO Output Current				100	mA

Connectors for DA9231 Evaluation

Table 5: DA9231 Input and Output Connectors

Connectors	Pin Names	Descriptions
J4 (VO_BUCK_SL)	+ / S+ / S- / -	+ and - are terminals for connecting external load to DA9231 Buck output; S+ and S- are kelvin sense points for DA9231 Buck output.
J7	VLDO_SL / AGND	Terminals for connecting external load to DA9231 LDO output.
J15	5V_USB / VDD_SYS_SL / VDD_SYS_M / S+ / S- / PGND	DA9231 Input supply selection and voltage sense. DA9231 input terminal (VDD_SYS_SL) can be selected from 5V_USB or VDD_SYS_M of DA9070. S+ and S- are kelvin sense points for DA9231 Buck input.
J22	VDD / IC_EN / AGND	Set IC_EN to VDD to automatically start the DA9231 when VDD is applied. Set IC_EN to AGND to completely disables the DA9231, including I2C communication.
J23	VDD_SYS_SL / VDD_LDO_SL / VO_BUCK_SL	LDO input supply selection. LDO input terminal VDD_LDO_SL can be selected from either DA9231 input VDD_SYS_SL or DA9231 Buck output VO_BUCK_SL.
J25	VO_BUCK_SL / VDDIO V2P5 / VDDIO VLDO_SL / VDDIO VO_BUCK_M / VDDIO	VDDIO voltage selection. VDDIO can be connected from 4 options by installing a jumper between VDDIO pin and the pin next to its left: DA9070 Buck, DA9231 Buck, DA9231 LDO, or independent 2.5V supply. For evaluation purposes, the 2.5V supply position is recommended to provide communications regardless of which IC is enabled.

Battery Profile Mode

The DA9070 Fuel gauge EVK board can also be configured to perform battery characterization (battery profile) and run a fuel gauge performance test. This is done using the Power Profile Manager (PPM) software instead of the DA9070 Fuel Gauge GUI. The profile data for a specific battery is generated by the PPM and loaded to the MCU. This profile is then used by the pre-loaded Dialog algorithm for the SOC fuel gauge.

If the included 80mAh battery is used, battery profiling is not necessary; the MCU is pre-loaded with both the fuel gauge algorithm and 80mAh battery profile.

Also pre-loaded to the MCU is the eval board calibration data. The calibration steps are described in AN-SW-121 but do not need to be performed in most cases.

Figure 9 shows the jumper set-up of the DA9070 Fuel gauge board while battery profiling is running. Note the jumper position of J14 in battery profile mode.

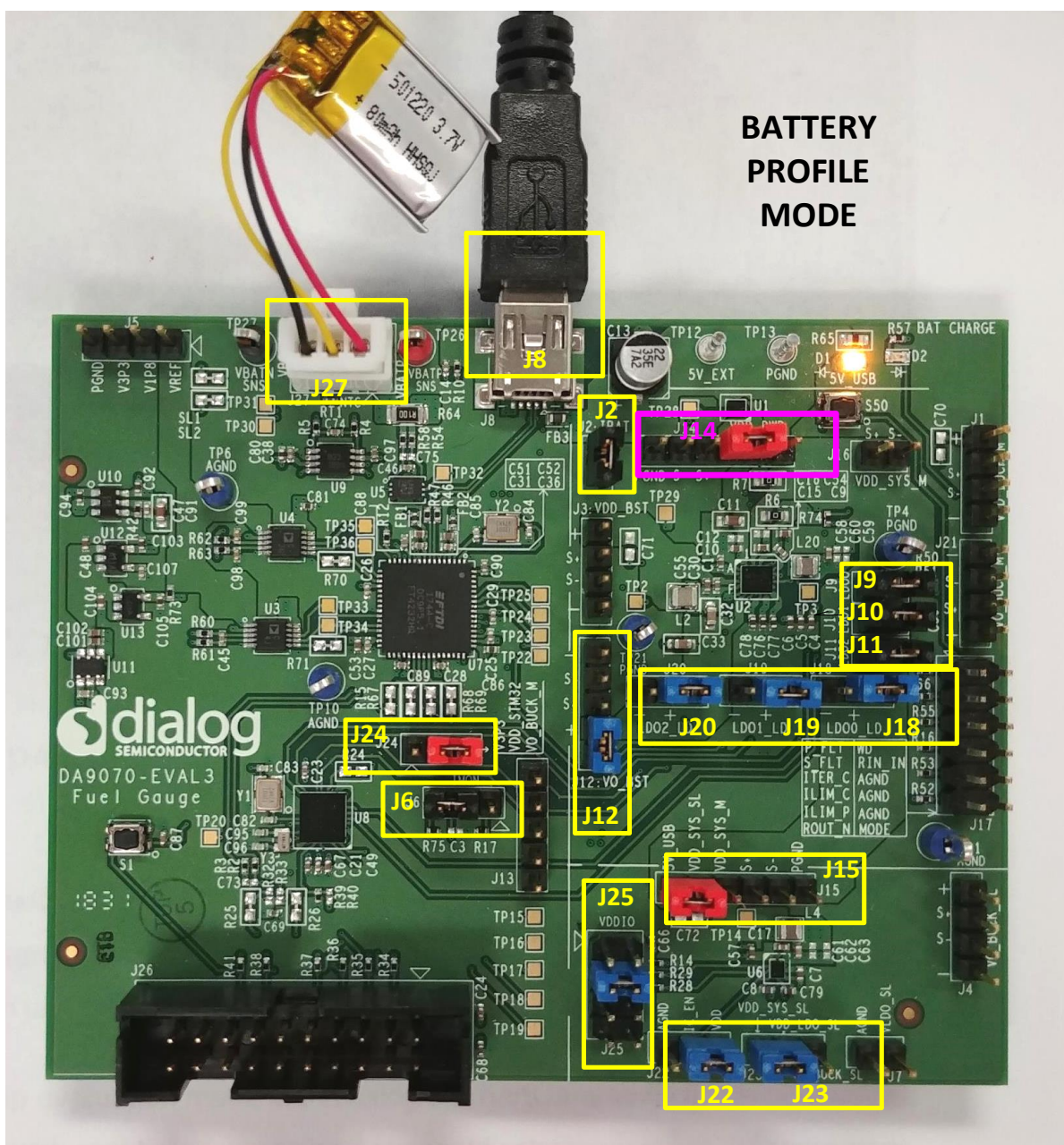

Figure 9: Jumper Settings for Battery Profile Mode

The entire battery profile process includes battery profiling, lookup table generation, and fuel gauge performance test. Board calibration can also be performed using the PPM software.

The main PPM windows are shown in Figure 10.

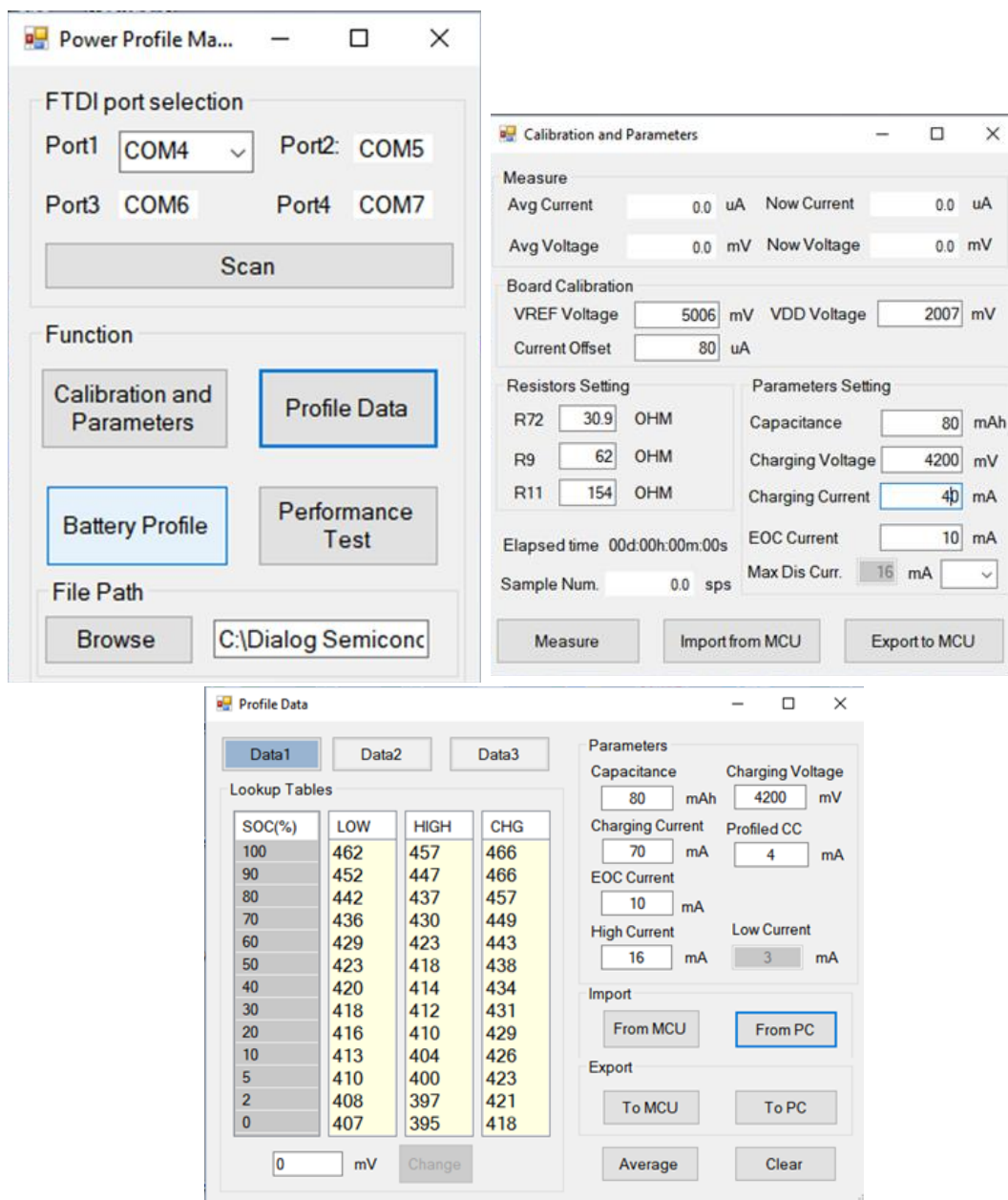

Figure 10: PPM windows

Please refer to Application Note AN-SW-121 DA9070 Power Profile Manager and SOCF for step-by-step instructions on how to perform these tests.

Revision History

Revision	Date	Description
1.0	12-12-2017	Initial version
2.0	28-10-2018	Updated for EVAL 3
2.1	25-02-2022	Document rebranded to Renesas

Important Notice and Disclaimer

RENESAS ELECTRONICS CORPORATION AND ITS SUBSIDIARIES ("RENESAS") PROVIDES TECHNICAL SPECIFICATIONS AND RELIABILITY DATA (INCLUDING DATASHEETS), DESIGN RESOURCES (INCLUDING REFERENCE DESIGNS), APPLICATION OR OTHER DESIGN ADVICE, WEB TOOLS, SAFETY INFORMATION, AND OTHER RESOURCES "AS IS" AND WITH ALL FAULTS, AND DISCLAIMS ALL WARRANTIES, EXPRESS OR IMPLIED, INCLUDING, WITHOUT LIMITATION, ANY IMPLIED WARRANTIES OF MERCHANTABILITY, FITNESS FOR A PARTICULAR PURPOSE, OR NON-INFRINGEMENT OF THIRD PARTY INTELLECTUAL PROPERTY RIGHTS.

These resources are intended for developers skilled in the art designing with Renesas products. You are solely responsible for (1) selecting the appropriate products for your application, (2) designing, validating, and testing your application, and (3) ensuring your application meets applicable standards, and any other safety, security, or other requirements. These resources are subject to change without notice. Renesas grants you permission to use these resources only for development of an application that uses Renesas products. Other reproduction or use of these resources is strictly prohibited. No license is granted to any other Renesas intellectual property or to any third party intellectual property. Renesas disclaims responsibility for, and you will fully indemnify Renesas and its representatives against, any claims, damages, costs, losses, or liabilities arising out of your use of these resources. Renesas' products are provided only subject to Renesas' Terms and Conditions of Sale or other applicable terms agreed to in writing. No use of any Renesas resources expands or otherwise alters any applicable warranties or warranty disclaimers for these products.

© 2022 Renesas Electronics Corporation. All rights reserved.

(Rev.1.0 Mar 2020)

Corporate Headquarters

TOYOSU FORESIA, 3-2-24 Toyosu

Koto-ku, Tokyo 135-0061, Japan

www.renesas.com

Contact Information

For further information on a product, technology, the most up-to-date version of a document, or your nearest sales office, please visit:

<https://www.renesas.com/contact/>

Trademarks

Renesas and the Renesas logo are trademarks of Renesas Electronics Corporation. All trademarks and registered trademarks are the property of their respective owners.

IMPORTANT NOTICE AND DISCLAIMER

RENESAS ELECTRONICS CORPORATION AND ITS SUBSIDIARIES (“RENESAS”) PROVIDES TECHNICAL SPECIFICATIONS AND RELIABILITY DATA (INCLUDING DATASHEETS), DESIGN RESOURCES (INCLUDING REFERENCE DESIGNS), APPLICATION OR OTHER DESIGN ADVICE, WEB TOOLS, SAFETY INFORMATION, AND OTHER RESOURCES “AS IS” AND WITH ALL FAULTS, AND DISCLAIMS ALL WARRANTIES, EXPRESS OR IMPLIED, INCLUDING, WITHOUT LIMITATION, ANY IMPLIED WARRANTIES OF MERCHANTABILITY, FITNESS FOR A PARTICULAR PURPOSE, OR NON-INFRINGEMENT OF THIRD-PARTY INTELLECTUAL PROPERTY RIGHTS.

These resources are intended for developers who are designing with Renesas products. You are solely responsible for (1) selecting the appropriate products for your application, (2) designing, validating, and testing your application, and (3) ensuring your application meets applicable standards, and any other safety, security, or other requirements. These resources are subject to change without notice. Renesas grants you permission to use these resources only to develop an application that uses Renesas products. Other reproduction or use of these resources is strictly prohibited. No license is granted to any other Renesas intellectual property or to any third-party intellectual property. Renesas disclaims responsibility for, and you will fully indemnify Renesas and its representatives against, any claims, damages, costs, losses, or liabilities arising from your use of these resources. Renesas' products are provided only subject to Renesas' Terms and Conditions of Sale or other applicable terms agreed to in writing. No use of any Renesas resources expands or otherwise alters any applicable warranties or warranty disclaimers for these products.

(Disclaimer Rev.1.01 Jan 2024)

Corporate Headquarters

TOYOSU FORESIA, 3-2-24 Toyosu,
Koto-ku, Tokyo 135-0061, Japan
www.renesas.com

Trademarks

Renesas and the Renesas logo are trademarks of Renesas Electronics Corporation. All trademarks and registered trademarks are the property of their respective owners.

Contact Information

For further information on a product, technology, the most up-to-date version of a document, or your nearest sales office, please visit www.renesas.com/contact-us/.