

Designing Stable Compensation Networks for Single Phase Voltage Mode Buck Regulators

TB417
Rev.1.00
Dec 2003

Assumptions

This Technical Brief makes the following assumptions:

1. The power supply designer has already designed the power stage of the single phase buck converter. The last step to the design is the compensation network.
2. The designer has at least a basic understanding of control systems theory.
3. The designer has a basic understanding of Bode plots.

Introduction

Synchronous and non-synchronous buck regulators have three basic blocks that contribute to the closed loop system. These blocks consist of the modulator, the output filter, and the compensation network which closes the loop and stabilizes the system.

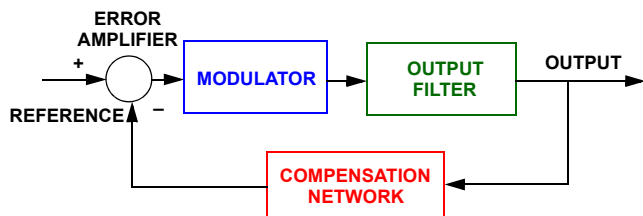

FIGURE 1. BASIC BLOCKS OF THE BUCK REGULATOR

Modulator

The modulator is shown in Figure 2. The input to the modulator is the output of the error amplifier, which is used to compare the output to the reference.

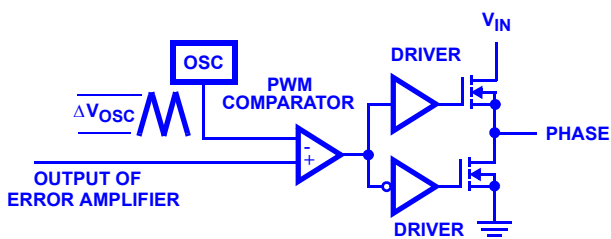

FIGURE 2. THE MODULATOR

The output of the modulator is the PHASE node. The gain of the modulator is simply the input voltage to the regulator, V_{IN} , divided by the peak-to-peak voltage of the oscillator, ΔV_{OSC} . or:

$$GAIN_{MODULATOR} = \frac{V_{IN}}{\Delta V_{OSC}}$$

The peak to peak voltage of the oscillator can be obtained from the data sheet for the controller IC.

Output Filter

The output filter consists of the output inductor and all of the output capacitance. It is important to include the DC resistance (DCR) of the output inductor and the total Equivalent Series Resistance (ESR) of the output capacitor bank. The input to the output filter is the PHASE node and the output is the regulator output. Figure 3 shows the equivalent circuit of the output filter and its transfer function.

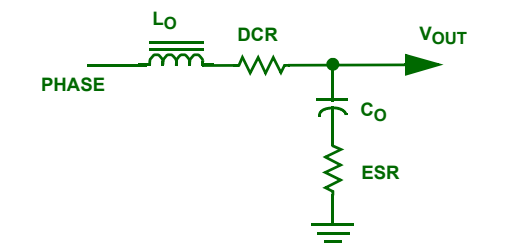

$$GAIN_{FILTER} = \frac{1 + s \cdot ESR \cdot C_{OUT}}{1 + s \cdot (ESR + DCR) \cdot C_{OUT} + s^2 \cdot L_{OUT} \cdot C_{OUT}}$$

FIGURE 3. THE OUTPUT FILTER

The transfer function for the output filter shows the well known double pole of an LC filter. It is important to note that the ESR of the capacitor bank and the DCR of the inductor both influence the damping of this resonant circuit. It is also important to notice the single zero that is a function of the output capacitance and its ESR.

Open Loop System

Figure 4 illustrates the open loop system and presents the transfer function.

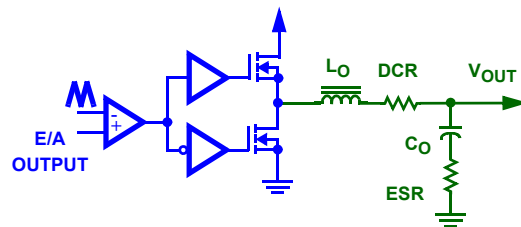

$$GAIN_{OPENLOOP} = \frac{V_{IN}}{\Delta V_{OSC}} \cdot \frac{1 + s \cdot ESR \cdot C_{OUT}}{1 + s \cdot (ESR + DCR) \cdot C_{OUT} + s^2 \cdot L_{OUT} \cdot C_{OUT}}$$

FIGURE 4. THE OPEN LOOP SYSTEM

Figure 5 shows the asymptotic Bode plot of the open loop system gain.

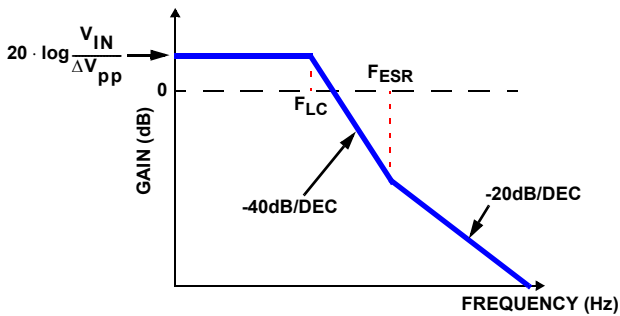

FIGURE 5. OPEN LOOP SYSTEM GAIN

Figure 5 represents a generic open loop system. Specific systems will have different double pole and ESR zero frequencies. For systems with very low DCR and ESR parameters, the phase will experience a very sharp slope downward at the double pole while the gain will have a rather high peak at the double pole. Systems that have such resonant output filters will be more difficult to compensate since the phase will need an extra boost to provide the necessary phase margin for stability. Systems such as this will typically need a Type III compensation, which will be discussed later in this brief.

Closing The Loop - The Compensation Network

Closing the control loop allows the regulator to adjust to load perturbations or changes in the input voltage which may adversely affect the output. Proper compensation of the system will allow for a predictable bandwidth with unconditional stability. In most cases, a Type II or Type III compensation network will properly compensate the system. The ideal Bode plot for the compensated system would be a gain that rolls off at a slope of -20dB/decade, crossing 0db at the desired bandwidth and a phase margin greater than 45° for all frequencies below the 0dB crossing. For synchronous and non-synchronous buck converters, the bandwidth should be between 20 to 30% of the switching frequency.

Type II Compensation

Figure 6 shows a generic Type II compensation, its transfer function and asymptotic Bode plot. The Type II network helps to shape the profile of the gain with respect to frequency and also gives a 90° boost to the phase. This boost is necessary to counteract the effects of the resonant output filter at the double pole.

If the output voltage of the regulator is not the reference voltage then a voltage programming resistor will be connected between the inverting input to the error amplifier and ground. This resistor is used to offset the output voltage to a level higher than the reference. This resistor, if present, has no effect on the compensation and can be ignored.

Figure 7 shows the closed loop system with a Type II compensation network and presents the closed loop transfer function.

The following guidelines will help calculate the poles and zeroes, and from those the component values, for a Type II network.

1. Choose a value for R_1 , usually between 2k and 5kΩ.
2. Pick a gain (R_2/R_1) that will shift the Open Loop Gain up to give the desired bandwidth. This will allow the 0dB crossover to occur in the frequency range where the Type II network has a flat gain. The following equation will calculate an R_2 that will accomplish this given the system parameters and a chosen R_1 .

$$R_2 = \left(\frac{F_{ESR}}{F_{LC}} \right)^2 \cdot \frac{DBW}{F_{ESR}} \cdot \frac{\Delta V_{OSC}}{V_{IN}} \cdot R_1$$

3. Calculate C_2 by placing the zero a decade below the output filter double pole frequency:

$$C_2 = \frac{10}{2\pi \cdot R_2 \cdot F_{LC}}$$

4. Calculate C_1 by placing the second pole at half the switching frequency:

$$C_1 = \frac{C_2}{\pi \cdot R_2 \cdot C_2 \cdot F_{sw}^{-1}}$$

Figure 8 shows the asymptotic Bode gain plot and the actual gain and phase equations for the Type II compensated system. It is recommended that the actual gain and phase plots be generated through the use of commercially available analytical software. Some examples of software that can be used are Mathcad, Maple, and Excel. The asymptotic plot of the gain and phase does not portray all the necessary information that is needed to determine stability and bandwidth.

The compensation gain must be compared to the open loop gain of the error amplifier. The compensation gain should not exceed the error amplifier open loop gain because this is the limiting factor of the compensation. Once the gain and phase plots are generated and analyzed, the system may need to be changed somewhat in order adjust the bandwidth or phase margin. Adjust the location of the pole and/or zero to modify the profile of the plots.

If the phase margin proves too difficult to correct, then a Type III system may be needed.

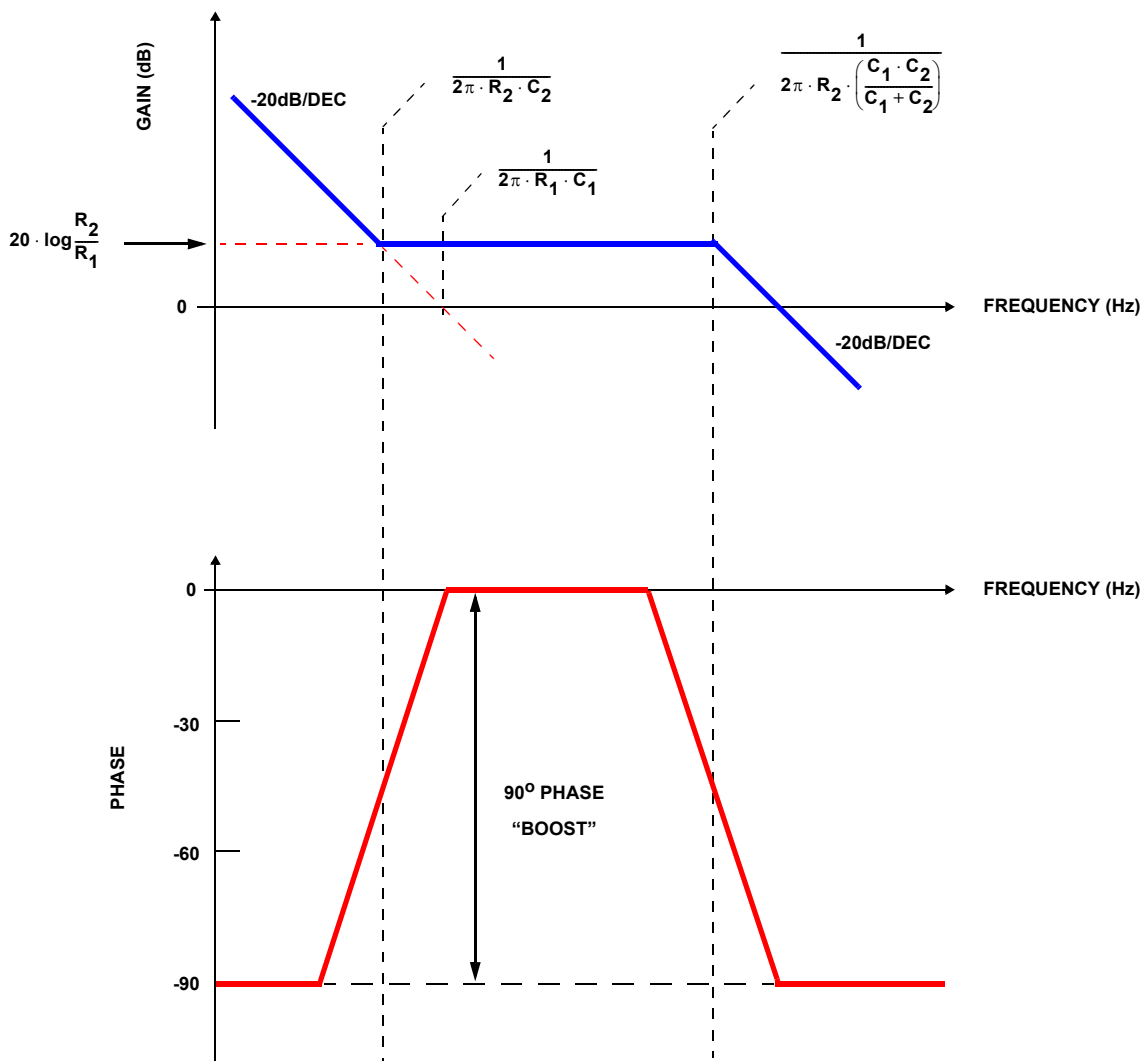
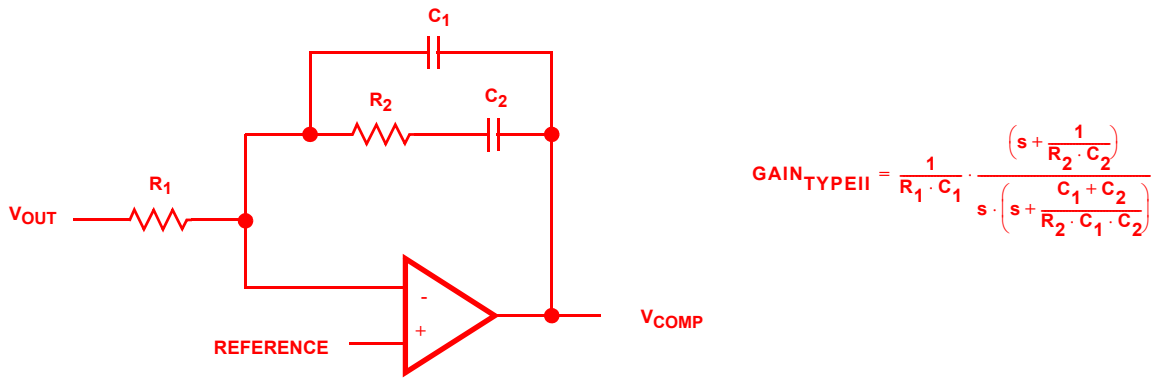

FIGURE 6. GENERIC TYPE II NETWORK

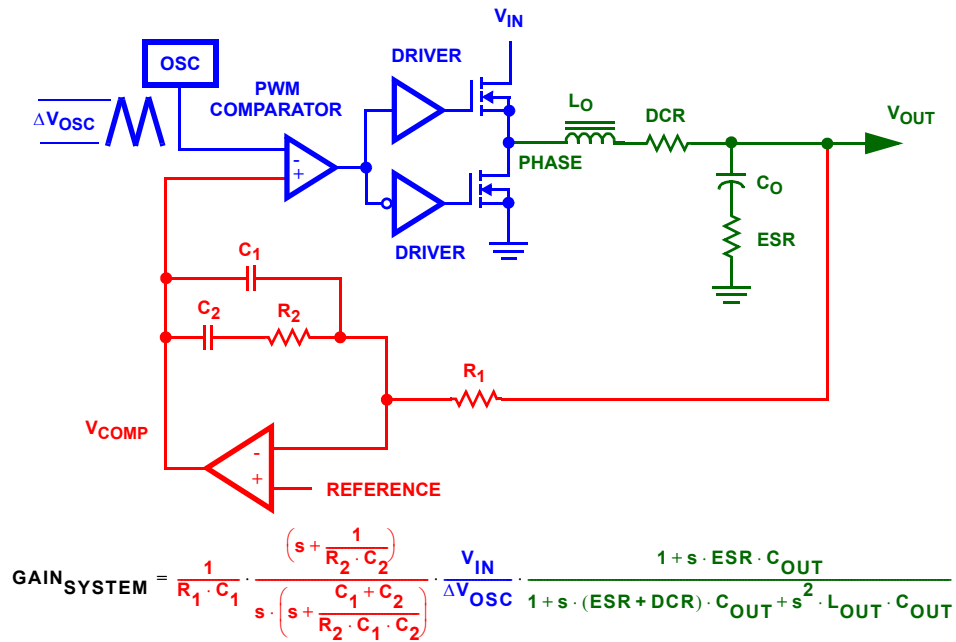
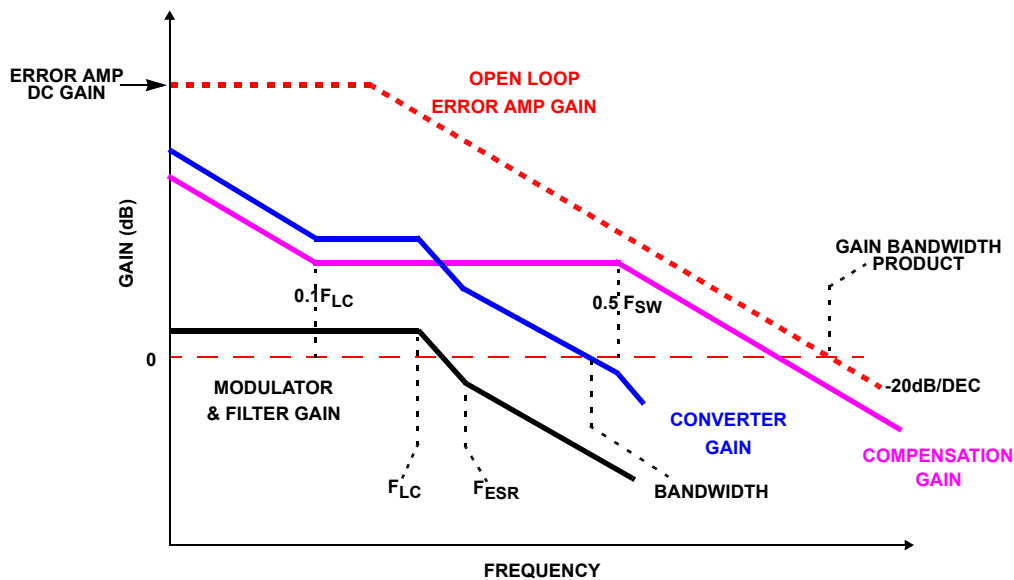

FIGURE 7. CLOSED LOOP SYSTEM WITH TYPE II NETWORK



$$GAIN_{dB}(f) = GAIN_{MODULATOR} + GAIN_{FILTER} + GAIN_{TYPEII}$$

$$PHASE(f) = PHASE_{MODULATOR} + PHASE_{FILTER} + PHASE_{TYPEII}$$

Where: $GAIN_{MODULATOR} = 20 \cdot \log\left(\frac{V_{IN}}{\Delta V_{OSC}}\right)$

$$GAIN_{FILTER} = 10 \cdot \log\left[1 + (2\pi f \cdot ESR \cdot C_{OUT})^2\right] - 10 \cdot \log\left[\frac{1 + (2\pi f)^2 \cdot L_{OUT} \cdot C_{OUT}}{1 + (2\pi f \cdot (ESR + DCR) \cdot C_{OUT})^2}\right]$$

$$PHASE_{FILTER} = \text{atan}[2\pi f \cdot ESR \cdot C_{OUT}] + \text{atan}\left[\frac{2\pi f \cdot ESR + DCR \cdot C_{OUT}}{2\pi f^2 \cdot L_{OUT} \cdot C_{OUT} - 1}\right]$$

$$GAIN_{TYPEII} = 10 \cdot \log\left[1 + (2\pi f \cdot R_2 \cdot C_2)^2\right] - 20 \cdot \log[2\pi f \cdot R_1 \cdot (C_1 + C_2)] - 10 \cdot \log\left[1 + \left(2\pi f \cdot R_2 \cdot \frac{C_1 \cdot C_2}{C_1 + C_2}\right)^2\right]$$

$$PHASE_{TYPEII} = -90^\circ + \text{atan}[2\pi f \cdot R_2 \cdot C_2] - \text{atan}\left[2\pi f \cdot R_2 \cdot \frac{C_1 \cdot C_2}{C_1 + C_2}\right]$$

FIGURE 8. TYPE II COMPENSATED NETWORK

Type III Compensation

Figure 9 shows a generic Type III compensation, its transfer function and asymptotic Bode plot. The Type III network shapes the profile of the gain with respect to frequency in a similar fashion to the Type II network. The Type III network, however, utilizes two zeroes to give a phase boost of 180°. This boost is necessary to counteract the effects of an under damped resonance of the output filter at the double pole.

Figure 10 shows the closed loop system with a Type III compensation network and presents the closed loop transfer function.

The guidelines for positioning the poles and zeroes and for calculating the component values are similar to the guidelines for the Type II network.

1. Choose a value for R_1 , usually between 2k and 5kΩ.
2. Pick a gain (R_2/R_1) that will shift the Open Loop Gain up to give the desired bandwidth. This will allow the 0dB crossover to occur in the frequency range where the Type III network has its second flat gain. The following equation will calculate an R_2 that will accomplish this given the system parameters and a chosen R_1 .

$$R_2 = \frac{\text{DBW}}{F_{LC}} \cdot \frac{\Delta V_{OSC}}{V_{IN}} \cdot R_1$$

3. Calculate C_2 by placing the zero at 50% of the output filter double pole frequency:

$$C_2 = \frac{1}{\pi \cdot R_2 \cdot F_{LC}}$$

4. Calculate C_1 by placing the first pole at the ESR zero frequency:

$$C_1 = \frac{C_2}{2 \cdot \pi \cdot R_2 \cdot C_2 \cdot F_{ESR} - 1}$$

5. Set the second pole at half the switching frequency and also set the second zero at the output filter double pole. This combination will yield the following component calculations:

$$R_3 = \frac{R_1}{\frac{F_{SW}}{2 \cdot F_{LC}} - 1}$$

$$C_3 = \frac{1}{\pi \cdot R_3 \cdot F_{SW}}$$

Figure 11 shows the asymptotic Bode gain plot for the Type III compensated system and the gain and phase equations for the compensated system. As with the Type II compensation network, it is recommended that the actual gain and phase plots be generated through the use of a commercially available analytical software package that has the capability to plot.

The compensation gain must be compared to the open loop gain of the error amplifier. The compensation gain should not exceed the error amplifier open loop gain because this is the limiting factor of the compensation. Once the gain and phase plots are generated the system may need to be changed after it is analyzed. Adjust the poles and/or zeroes in order to shape the gain profile and insure that the phase margin is greater than 45°.

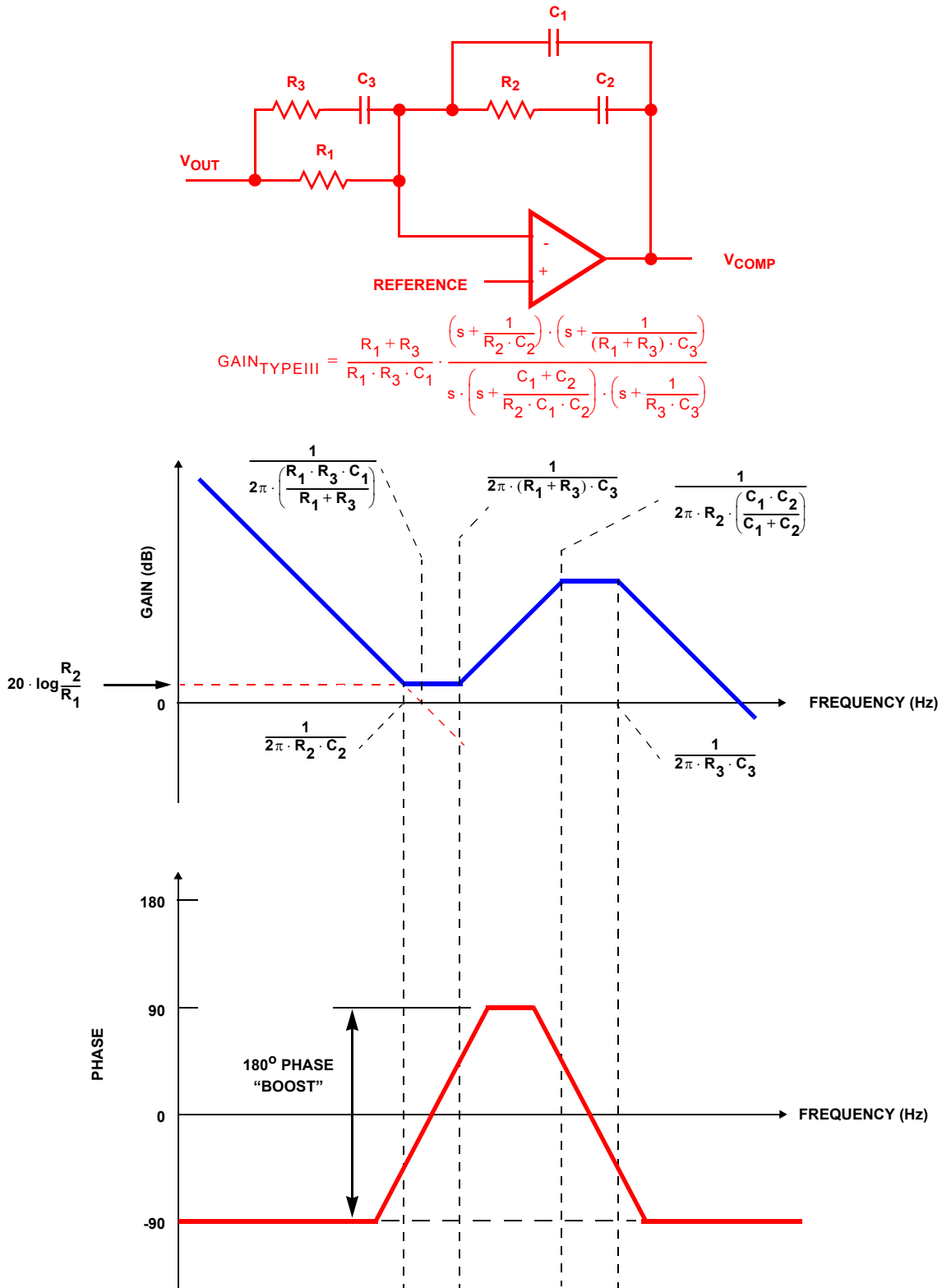

FIGURE 9. GENERIC TYPE III NETWORK

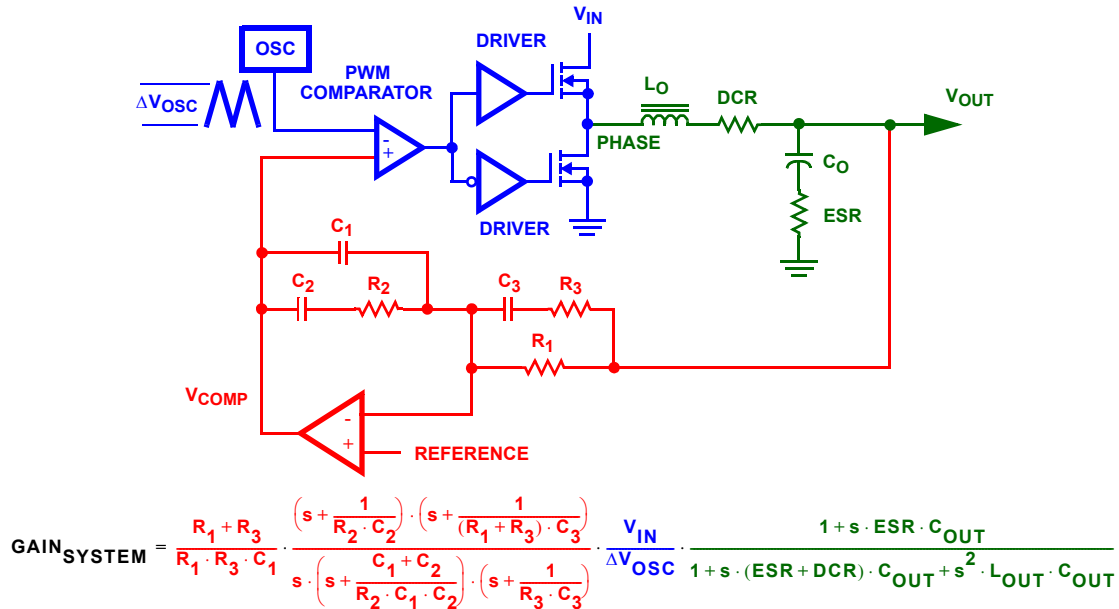
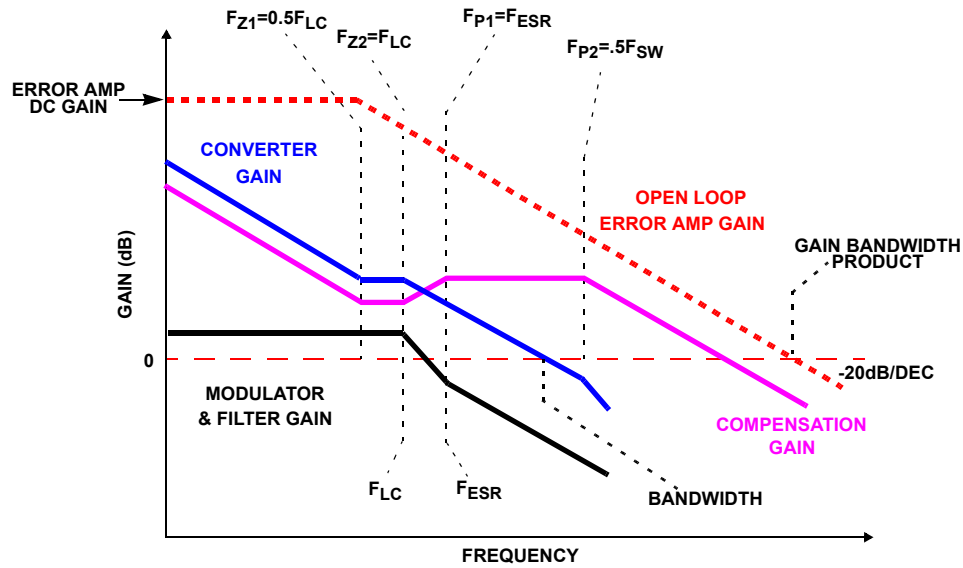

FIGURE 10. CLOSED LOOP SYSTEM WITH TYPE III NETWORK



$$GAIN_{dB}(f) = GAIN_{MODULATOR} + GAIN_{FILTER} + GAIN_{TYPEIII}$$

$$PHASE(f) = PHASE_{MODULATOR} + PHASE_{FILTER} + PHASE_{TYPEIII}$$

Where: $GAIN_{MODULATOR} = 20 \cdot \log\left(\frac{V_{IN}}{\Delta V_{OSC}}\right)$

$$GAIN_{FILTER} = 10 \cdot \log\left[1 + (2\pi f \cdot ESR \cdot C_{OUT})^2\right] - 10 \cdot \log\left[\left(1 - (2\pi f)^2 \cdot L_{OUT} \cdot C_{OUT}\right)^2 + (2\pi f \cdot (ESR + DCR) \cdot C_{OUT})^2\right]$$

$$PHASE_{FILTER} = \text{atan}[2\pi f \cdot ESR \cdot C_{OUT}] + \text{atan}\left[\frac{2\pi f \cdot ESR + DCR \cdot C_{OUT}}{2\pi f^2 \cdot L_{OUT} \cdot C_{OUT} - 1}\right]$$

$$GAIN_{TYPEIII} = 10 \cdot \log\left[1 + (2\pi f \cdot R_2 \cdot C_2)^2\right] - 20 \cdot \log[2\pi f \cdot R_1 \cdot (C_1 + C_2)] - 10 \cdot \log\left[1 + \left(2\pi f \cdot R_2 \cdot \left(\frac{C_1 \cdot C_2}{C_1 + C_2}\right)\right)^2\right] + 10 \cdot \log\left[1 + (2\pi f \cdot (R_1 + R_3) \cdot C_3)^2\right] - 10 \cdot \log\left[1 + (2\pi f \cdot R_3 \cdot C_3)^2\right]$$

$$PHASE_{TYPEIII} = -90^\circ + \text{atan}[2\pi f \cdot R_2 \cdot C_2] - \text{atan}\left[2\pi f \cdot R_2 \cdot \left(\frac{C_1 \cdot C_2}{C_1 + C_2}\right)\right] + \text{atan}[2\pi f \cdot (R_1 + R_3) \cdot C_3] - \text{atan}[2\pi f \cdot R_3 \cdot C_3]$$

FIGURE 11. TYPE III COMPENSATED NETWORK

Example

The following example will illustrate the entire process of compensation design for a synchronous buck converter.

Converter Parameters

Input Voltage:	V_{IN}	5V
Output Voltage:	V_{OUT}	3.3V
Controller IC:	IC	ISL6520A
Osc. Voltage:	ΔV_{OSC}	1.5V
Switching Frequency:	f_{SW}	300kHz
Total Output Capacitance:	C_{OUT}	990 μ F
Total ESR:	ESR	5m Ω
Output Inductance:	L_{OUT}	900nH
Inductor DCR:	DCR	3m Ω
Desired Bandwidth:	DBW	90kHz

First, a Type II compensation network will be attempted. The low ESR of the output capacitance and the low DCR of the output inductor may make the implementation of a Type II network difficult.

The guidelines given for designing a Type II network were followed in order to calculate the following component values:

$$\begin{aligned} R_1 &= 4.12k\Omega \text{ (chosen as the feedback component)} \\ R_2 &= 125.8k\Omega \\ C_1 &= 8.464pF \\ C_2 &= 2.373nF \end{aligned}$$

These calculated values need to be replaced by standard resistor values before the gain and phase plots can be plotted and examined.

$$\begin{aligned} R_1 &= 4.12k\Omega \\ R_2 &= 124k\Omega \\ C_1 &= 8.2pF \\ C_2 &= 2.2nF \end{aligned}$$

Upon analysis of the bode plots in Figure 12, it can be seen that the system does not meet the stability criteria previously set. The bode plot for the gain is acceptable. The gain rolls off at 20dB/decade with a perturbation at the resonant point of the LC filter. After the perturbation, the gain again begins to roll off about 20dB/decade until it crosses 0dB right around 90kHz. The phase plot shows the problem with this Type II system. The low ESR and DCR values create a very sharp slope downward at the double pole of the LC filter.

The dive in the phase is so sharp that the 90° phase boost of the Type II network does not compensate the phase enough to have sufficient phase margin. At approximately 6kHz, the phase margin goes below 45° and never recovers. There is nothing more that the Type II system can do to improve the phase. The Phase of the compensation is at it's peak when the phase of the filter is at it's minimum.

Another problem with the Type II compensation network in this example is that the compensation gain intersects and then exceeds the gain of the error amplifier open loop gain. As the open loop gain of the error amplifier is the limiting factor to the compensation gain, the actual gain and phase is affected by the limit and will not exceed it.

Due to these issues, a Type III network will need to be implemented to compensate for the phase properly.

The guidelines for the Type III network were then followed to produce the following component values:

$$\begin{aligned} R_1 &= 4.12k\Omega \text{ (chosen as the feedback component)} \\ R_2 &= 20.863k\Omega \\ R_3 &= 151.85\Omega \\ C_1 &= 0.2587nF \\ C_2 &= 2.861nF \\ C_3 &= 6.987nF \end{aligned}$$

Again, these calculated values need to be replaced by standard resistor values before the gain and phase plots can be plotted and examined.

$$\begin{aligned} R_1 &= 4.12k\Omega \\ R_2 &= 20.5k\Omega \\ R_3 &= 150\Omega \\ C_1 &= 0.22nF \\ C_2 &= 2.7nF \\ C_3 &= 6.8nF \end{aligned}$$

The gain plot of the Type III compensated system in Figure 13 looks very good. The gain rolls off at -20dB/decade from low frequency all the way to the 0dB crossover with a small perturbation from the LC filter double pole resonant point. The phase plot shows a system that is unconditionally stable.

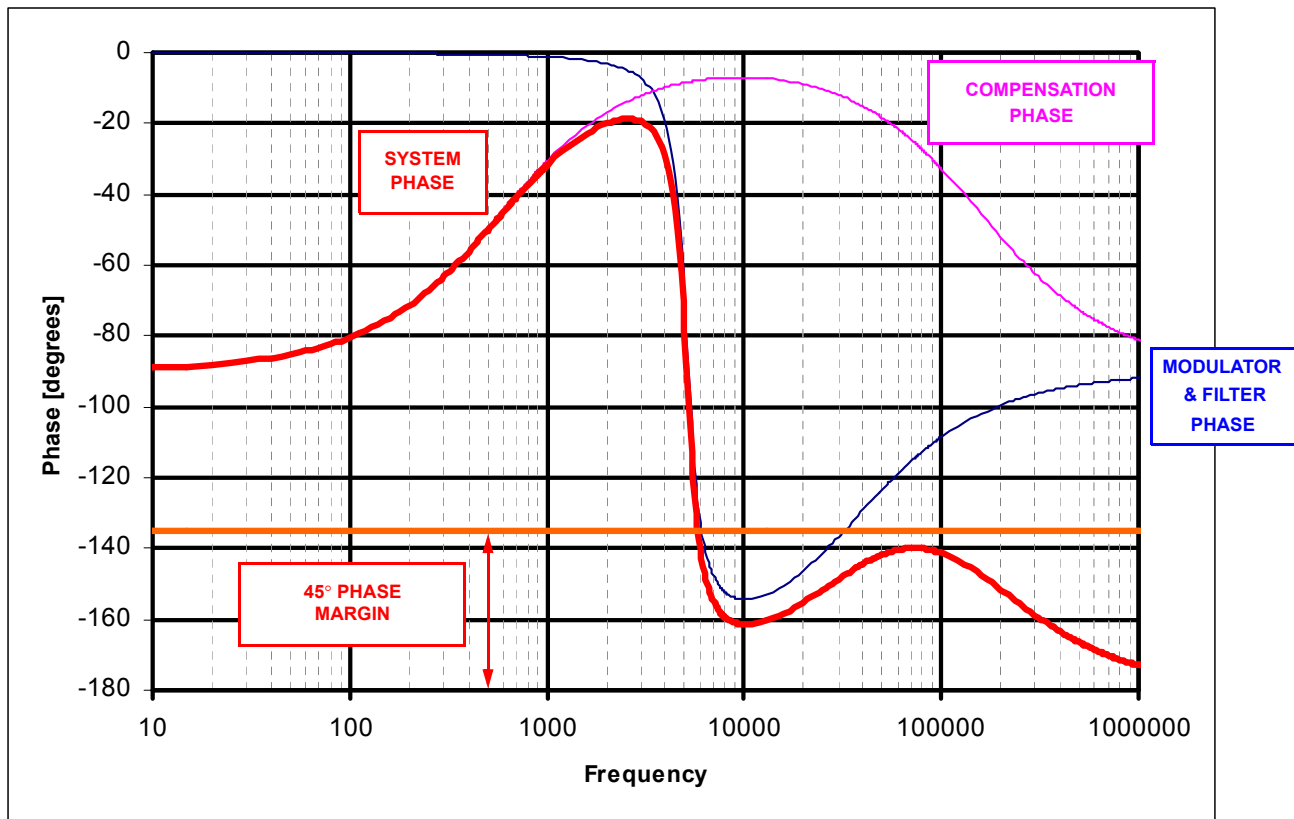
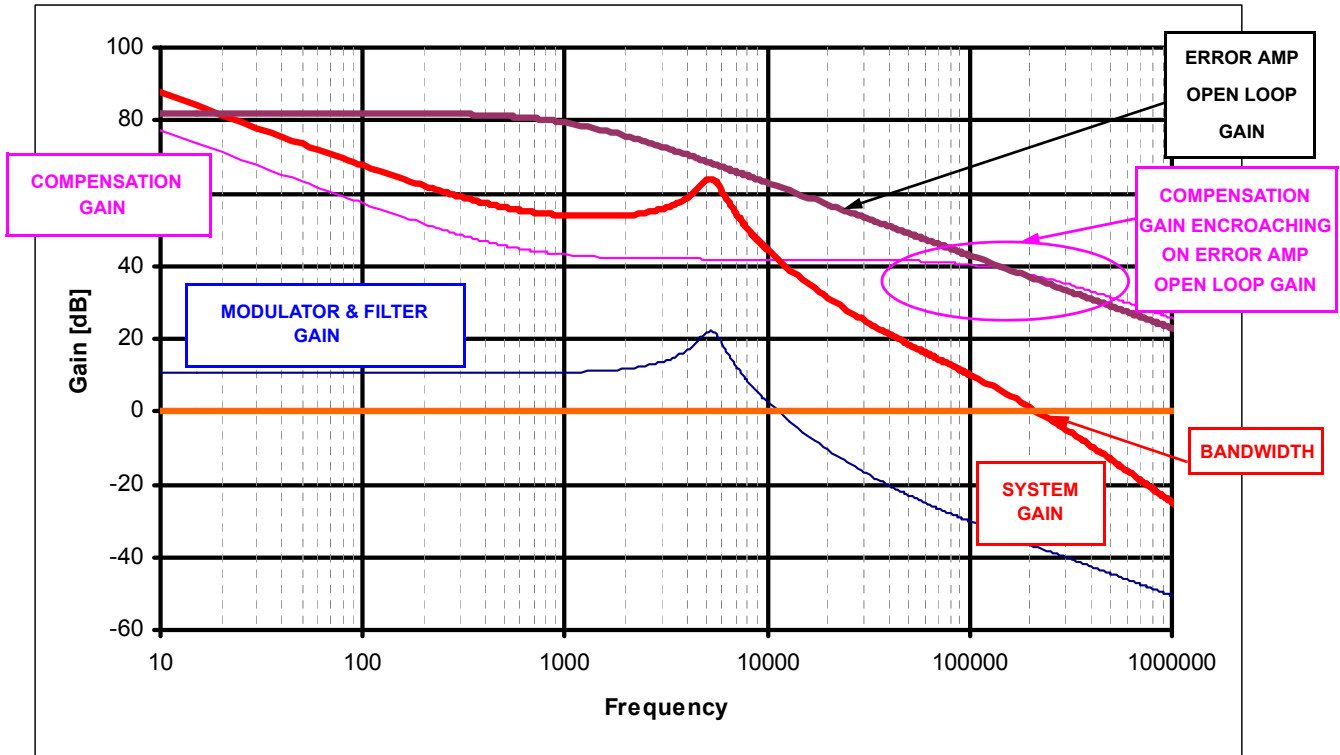

FIGURE 12. BODE PLOT OF THE TYPE II SYSTEM EXAMPLE

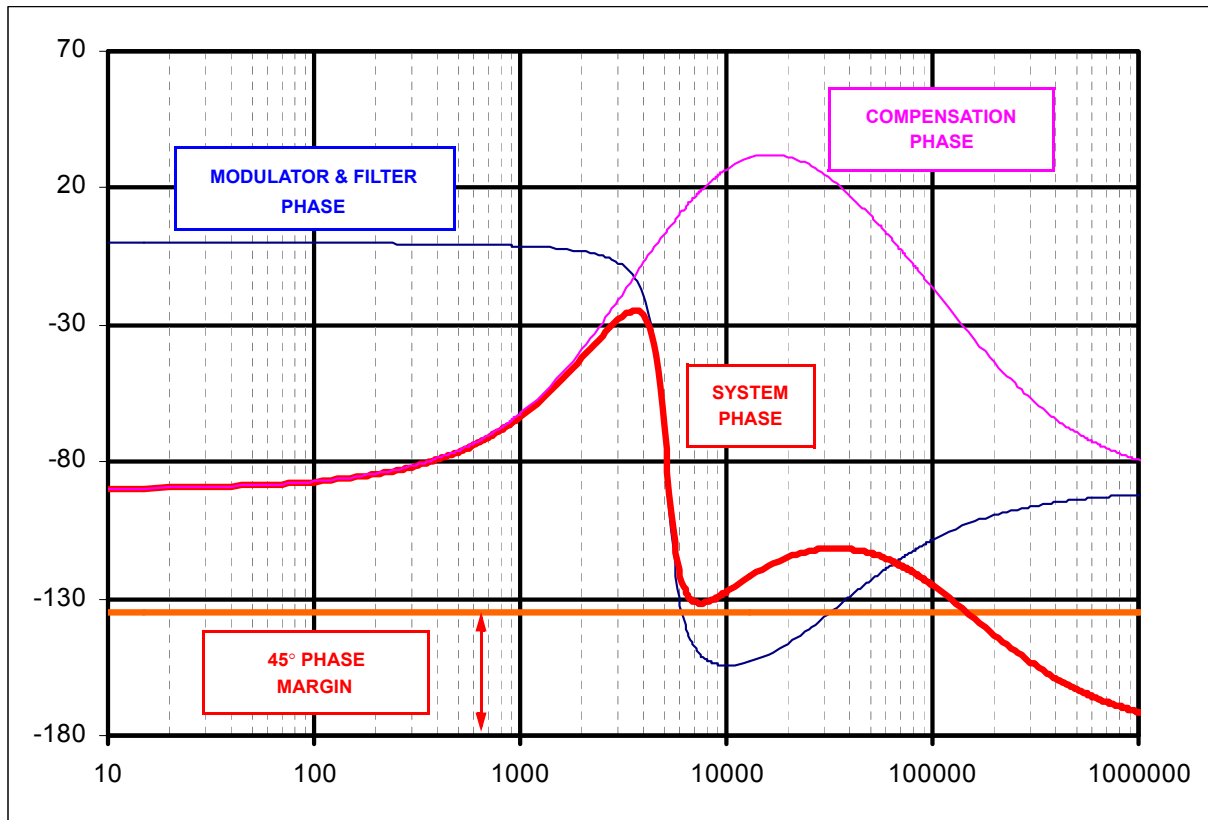
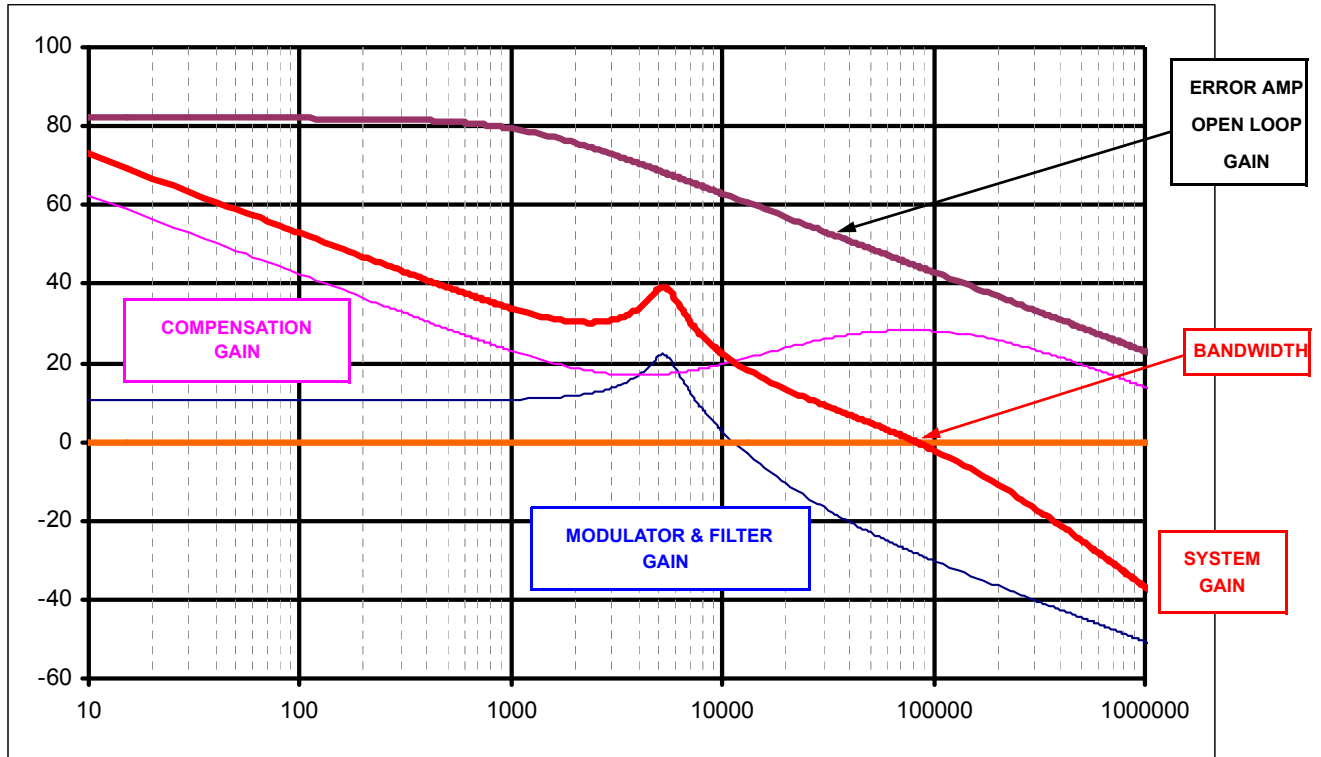

FIGURE 13. BODE PLOT OF THE TYPE III SYSTEM EXAMPLE

Notice

1. Descriptions of circuits, software and other related information in this document are provided only to illustrate the operation of semiconductor products and application examples. You are fully responsible for the incorporation or any other use of the circuits, software, and information in the design of your product or system. Renesas Electronics disclaims any and all liability for any losses and damages incurred by you or third parties arising from the use of these circuits, software, or information.
2. Renesas Electronics hereby expressly disclaims any warranties against and liability for infringement or any other claims involving patents, copyrights, or other intellectual property rights of third parties, by or arising from the use of Renesas Electronics products or technical information described in this document, including but not limited to, the product data, drawings, charts, programs, algorithms, and application examples.
3. No license, express, implied or otherwise, is granted hereby under any patents, copyrights or other intellectual property rights of Renesas Electronics or others.
4. You shall not alter, modify, copy, or reverse engineer any Renesas Electronics product, whether in whole or in part. Renesas Electronics disclaims any and all liability for any losses or damages incurred by you or third parties arising from such alteration, modification, copying or reverse engineering.
5. Renesas Electronics products are classified according to the following two quality grades: "Standard" and "High Quality". The intended applications for each Renesas Electronics product depends on the product's quality grade, as indicated below.
"Standard": Computers; office equipment; communications equipment; test and measurement equipment; audio and visual equipment; home electronic appliances; machine tools; personal electronic equipment; industrial robots; etc.
"High Quality": Transportation equipment (automobiles, trains, ships, etc.); traffic control (traffic lights); large-scale communication equipment; key financial terminal systems; safety control equipment; etc.
Unless expressly designated as a high reliability product or a product for harsh environments in a Renesas Electronics data sheet or other Renesas Electronics document, Renesas Electronics products are not intended or authorized for use in products or systems that may pose a direct threat to human life or bodily injury (artificial life support devices or systems; surgical implantations; etc.), or may cause serious property damage (space system; undersea repeaters; nuclear power control systems; aircraft control systems; key plant systems; military equipment; etc.). Renesas Electronics disclaims any and all liability for any damages or losses incurred by you or any third parties arising from the use of any Renesas Electronics product that is inconsistent with any Renesas Electronics data sheet, user's manual or other Renesas Electronics document.
6. When using Renesas Electronics products, refer to the latest product information (data sheets, user's manuals, application notes, "General Notes for Handling and Using Semiconductor Devices" in the reliability handbook, etc.), and ensure that usage conditions are within the ranges specified by Renesas Electronics with respect to maximum ratings, operating power supply voltage range, heat dissipation characteristics, installation, etc. Renesas Electronics disclaims any and all liability for any malfunctions, failure or accident arising out of the use of Renesas Electronics products outside of such specified ranges.
7. Although Renesas Electronics endeavors to improve the quality and reliability of Renesas Electronics products, semiconductor products have specific characteristics, such as the occurrence of failure at a certain rate and malfunctions under certain use conditions. Unless designated as a high reliability product or a product for harsh environments in a Renesas Electronics data sheet or other Renesas Electronics document, Renesas Electronics products are not subject to radiation resistance design. You are responsible for implementing safety measures to guard against the possibility of bodily injury, injury or damage caused by fire, and/or danger to the public in the event of a failure or malfunction of Renesas Electronics products, such as safety design for hardware and software, including but not limited to redundancy, fire control and malfunction prevention, appropriate treatment for aging degradation or any other appropriate measures. Because the evaluation of microcomputer software alone is very difficult and impractical, you are responsible for evaluating the safety of the final products or systems manufactured by you.
8. Please contact a Renesas Electronics sales office for details as to environmental matters such as the environmental compatibility of each Renesas Electronics product. You are responsible for carefully and sufficiently investigating applicable laws and regulations that regulate the inclusion or use of controlled substances, including without limitation, the EU RoHS Directive, and using Renesas Electronics products in compliance with all these applicable laws and regulations. Renesas Electronics disclaims any and all liability for damages or losses occurring as a result of your noncompliance with applicable laws and regulations.
9. Renesas Electronics products and technologies shall not be used for or incorporated into any products or systems whose manufacture, use, or sale is prohibited under any applicable domestic or foreign laws or regulations. You shall comply with any applicable export control laws and regulations promulgated and administered by the governments of any countries asserting jurisdiction over the parties or transactions.
10. It is the responsibility of the buyer or distributor of Renesas Electronics products, or any other party who distributes, disposes of, or otherwise sells or transfers the product to a third party, to notify such third party in advance of the contents and conditions set forth in this document.
11. This document shall not be reprinted, reproduced or duplicated in any form, in whole or in part, without prior written consent of Renesas Electronics.
12. Please contact a Renesas Electronics sales office if you have any questions regarding the information contained in this document or Renesas Electronics products.
(Note 1) "Renesas Electronics" as used in this document means Renesas Electronics Corporation and also includes its directly or indirectly controlled subsidiaries.
(Note 2) "Renesas Electronics product(s)" means any product developed or manufactured by or for Renesas Electronics.

(Rev.4.0-1 November 2017)



SALES OFFICES

Renesas Electronics Corporation

<http://www.renesas.com>

Refer to "<http://www.renesas.com/>" for the latest and detailed information.

Renesas Electronics America Inc.
1001 Murphy Ranch Road, Milpitas, CA 95035, U.S.A.
Tel: +1-408-432-8888, Fax: +1-408-434-5351

Renesas Electronics Canada Limited
9251 Yonge Street, Suite 8309 Richmond Hill, Ontario Canada L4C 9T3
Tel: +1-905-237-2004

Renesas Electronics Europe Limited
Dukes Meadow, Millboard Road, Bourne End, Buckinghamshire, SL8 5FH, U.K
Tel: +44-1628-651-700, Fax: +44-1628-651-804

Renesas Electronics Europe GmbH
Arcadiastrasse 10, 40472 Düsseldorf, Germany
Tel: +49-211-6503-0, Fax: +49-211-6503-1327

Renesas Electronics (China) Co., Ltd.
Room 1709 Quantum Plaza, No.27 ZhichunLu, Haidian District, Beijing, 100191 P. R. China
Tel: +86-10-8235-1155, Fax: +86-10-8235-7679

Renesas Electronics (Shanghai) Co., Ltd.
Unit 301, Tower A, Central Towers, 555 Langao Road, Putuo District, Shanghai, 200333 P. R. China
Tel: +86-21-2226-0888, Fax: +86-21-2226-0999

Renesas Electronics Hong Kong Limited
Unit 1601-1611, 16/F., Tower 2, Grand Century Place, 193 Prince Edward Road West, Mongkok, Kowloon, Hong Kong
Tel: +852-2265-6688, Fax: +852-2886-9022

Renesas Electronics Taiwan Co., Ltd.
13F, No. 363, Fu Shing North Road, Taipei 10543, Taiwan
Tel: +886-2-8175-9600, Fax: +886-2-8175-9670

Renesas Electronics Singapore Pte. Ltd.
80 Bendemeer Road, Unit #06-02 Hyflux Innovation Centre, Singapore 339949
Tel: +65-6213-0200, Fax: +65-6213-0300

Renesas Electronics Malaysia Sdn.Bhd.
Unit 1207, Block B, Menara Amcorp, Amcorp Trade Centre, No. 18, Jln Persiaran Barat, 46050 Petaling Jaya, Selangor Darul Ehsan, Malaysia
Tel: +60-3-7955-9390, Fax: +60-3-7955-9510

Renesas Electronics India Pvt. Ltd.
No.777C, 100 Feet Road, HAL 2nd Stage, Indiranagar, Bangalore 560 038, India
Tel: +91-80-67208700, Fax: +91-80-67208777

Renesas Electronics Korea Co., Ltd.
17F, KAMCO Yangjae Tower, 262, Gangnam-daero, Gangnam-gu, Seoul, 06265 Korea
Tel: +82-2-558-3737, Fax: +82-2-558-5338