

DA9063

System Power Management IC (PMIC) for applications providing up to 12 A continuous current

DA9063 is a powerful system PMIC for single-, dual-, and quad-core application processors such as those based on the ARM Cortex-A9™ and Cortex-A15™ architectures.

The DA9063 follows a scalable approach of output currents and rails to supply the entire system and is capable of delivering a total of up to 12 A from its six DC-DC buck converters. High efficiency is achieved over a wide load range by automatically selecting Pulse Frequency Modulation (PFM) or Pulse Width Modulation (PWM) modes. All bucks use integrated power switches, removing the need for external Schottky diodes. A high switching frequency allows low-profile inductors to be used. Two bucks can be combined in a 5 A dual-phase configuration, two offer a merged configuration for a combined 3 A, and one can be used as a DDR VTT supply. Eleven SmartMirror™ LDO regulators with programmable output voltage provide up to 300 mA each.

All LDOs support remote capacitor placement and can operate from a low voltage supply. This allows the LDOs to be cascaded with a suitable buck to improve overall system efficiency. A number of LDOs can be configured as current-limited bypass-switches to support external peripherals.

Processor core leakage is reduced by using the integrated rail switch controller to control external FET switches for ultra-fast power domain switching.

Controlled by a programmable digital power manager, the 17 user-programmable switched/linear regulators may be configured to meet the start-up sequence, voltage, and timing requirements for most applications. The power manager includes supply-rail qualification and system reset management. Dynamic Voltage Scaling (DVS) is available to achieve optimal processor energy-per-task performance. Dialog's patented SmartMirror™ dynamic biasing is implemented on all linear regulators.

Power mode transitions can be triggered with software control, GPIOs, or with button control.

Several types of button press can be used to trigger different power mode transitions. DVS can be realised via the I²C interface or GPIO control.

The low-power Real Time Clock (RTC) with an external crystal oscillator provides time-keeping, alarm and wakeup functions. In addition, a watchdog timer is included for system monitoring purposes.



Available in 100 VFBGA 8 mm x 8 mm x 1 mm, 0.8 mm pitch

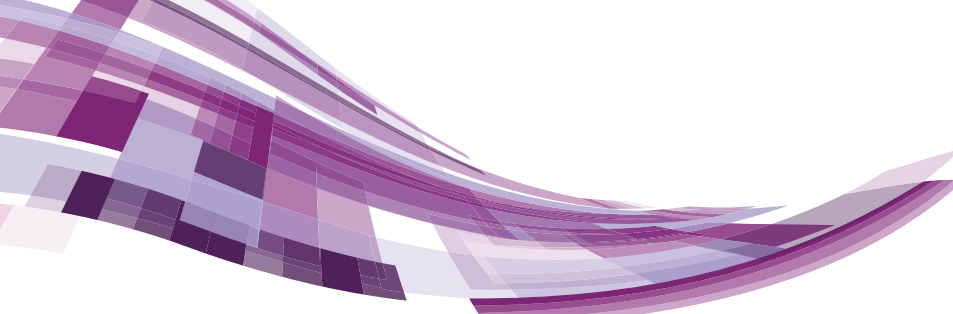

16 GPIOs can be used to implement system functions such as: application wakeup; buffered 32 kHz clock output; hardware regulator control; RGB-LED driver pins with PWM control; and sequencing control of external regulators, power switches, or other ICs such as the Dialog family of sub-PMICs.

An integrated 10-channel ADC includes advanced voltage monitoring, internal temperature supervision, three general-purpose channels with programmable high/low thresholds, an integrated current source for resistive measurements, and system voltage monitoring with a programmable low-voltage warning. The ADC has 8-bit resolution in AUTO mode and 10-bit resolution in manual conversion mode

Features

- ▶ Input voltage 2.8 V to 5.5 V
- ▶ Six buck converters, 0.3 V to 3.34 V up to 2.5 A
 - Dual-phase mode up to 5 A
 - Merged mode up to 3 A
 - DDR VTT supply mode
 - DVS support
- ▶ 3 MHz switching frequency allows use of low-profile 1 μ H inductors
- ▶ Integrated power switches
- ▶ 11 LDO regulators, 0.6 V to 3.6 V up to 300 mA
 - Three low-noise LDOs
 - Four with DVS
 - Five with current-limited switch option
- ▶ Fast controller for two rail switches
- ▶ Dual serial interfaces for system communication and control
 - One high-speed I²C compatible
 - One SPI/I²C selectable
- ▶ Programmable power manager
- ▶ System supply monitoring
- ▶ Junction temperature monitoring
- ▶ Watchdog timer
- ▶ Coin cell/super-capacitor backup charger
- ▶ 1.5 μ A RTC with alarm and wakeup
- ▶ 16 flexible GPIO pins for enhanced wakeup and peripheral control
- ▶ RGB-LED driver (PWM) with autonomous flashing
- ▶ PWM vibrator driver
- ▶ 10-bit ADC with nine channels and configurable alarm thresholds
- ▶ -40 °C to +125 °C junction temperature operation
- ▶ Automotive AEC-Q100 Grade 3 version

Typical applications

- ▶ Smartphones
- ▶ Ultrabooks
- ▶ Tablets, e-books
- ▶ Car infotainment and ADAS
- ▶ Navigation devices
- ▶ Set-top boxes, TV, and media players
- ▶ Portable medical devices
- ▶ Industrial control

Block diagram

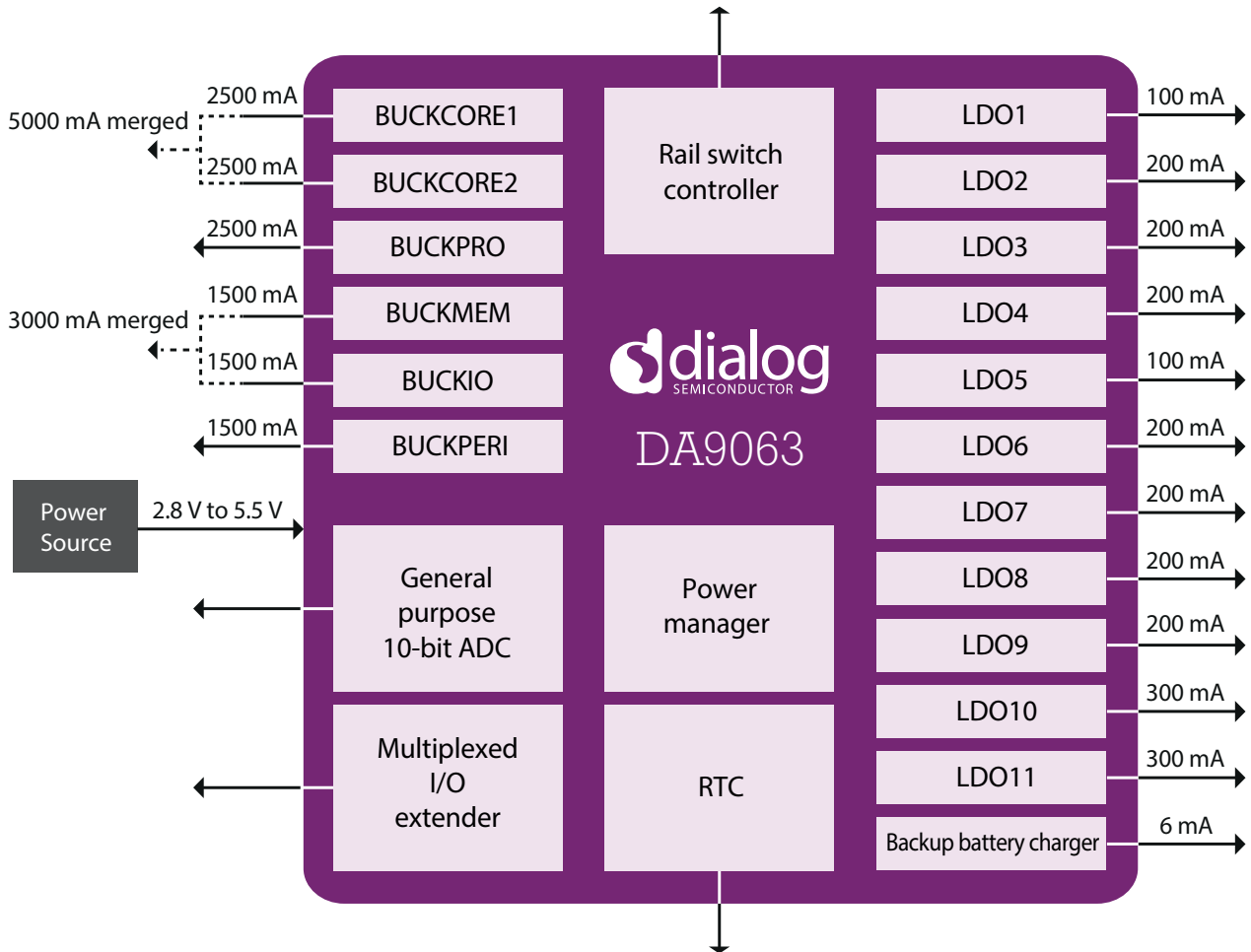

Generated supply domains

Regulator	Supplied voltage	Supplied max. current	External component	Notes
BUCKCORE1	0.3 V to 1.57 V	2.5 A	1.0 μ H / 2 x 47 μ F	3 MHz, DVS with variable slew rate, 10 mV steps
BUCKCORE2	0.3 V to 1.57 V	2.5 A	1.0 μ H / 2 x 47 μ F	3 MHz, DVS with variable slew rate, 10 mV steps, can be combined with BUCKCORE1 as a 5 A dual-phase buck
BUCKPRO	0.53 V to 1.80 V	2.5 A	1.0 μ H / 2 x 47 μ F	3 MHz, DVS with variable slew rate, 10 mV steps, can be used as a DDR VTT supply
BUCKMEM	0.8 V to 3.34 V	1.5 A	1.0 μ H / 2 x 22 μ F	3 MHz, DVS with variable slew rate, 20 mV steps, 3 A merged mode with BUCKIO
BUCKIO	0.8 V to 3.34 V	1.5 A	1.0 μ H / 2 x 22 μ F	3 MHz, DVS with variable slew rate, 20 mV steps
BUCKPERI	0.8 V to 3.34 V	1.5 A	1.0 μ H / 2 x 22 μ F	3 MHz, DVS with variable slew rate, 20 mV steps
LDO1	0.6 V to 1.86 V	100 mA	1.0 μ F	Bypass mode, 20 mV steps, DVS with variable slew rate, optional voltage tracking of BUCKCORE or BUCKPRO
LDO2	0.6 V to 1.86 V	200 mA	2.2 μ F	20 mV steps, DVS with variable slew rate
LDO3	0.9 V to 3.44 V	200 mA	2.2 μ F	Bypass mode, 20 mV steps, DVS with variable slew rate
LDO4	0.9 V to 3.44 V	200 mA	2.2 μ F	Bypass mode, 20 mV steps, DVS with variable slew rate
LDO5	0.9 V to 3.6 V	100 mA	1.0 μ F	50 mV steps
LDO6	0.9 V to 3.6 V	200 mA	2.2 μ F	Low noise, 50 mV steps
LDO7	0.9 V to 3.6 V	200 mA	2.2 μ F	Bypass mode, 50 mV steps
LDO8	0.9 V to 3.6 V	200 mA	2.2 μ F	Bypass mode, switching vibration motor driver mode, 50 mV steps
LDO9	0.95 V to 3.6 V	200 mA	2.2 μ F	Low noise, 50 mV steps
LDO10	0.9 V to 3.6 V	300 mA	2.2 μ F	Low noise LDO, 50 mV steps
LDO11	0.9 V to 3.6 V	300 mA	2.2 μ F	Bypass mode, 50 mV steps
BACKUP	1.1 V to 3.1 V	6 mA	470 nF	100 mV / 200 mV steps, configurable current limit between 100 μ A and 6000 μ A, reverse current protection

Dialog Semiconductor Worldwide Sales Offices - www.dialog-semiconductor.com

email: info@diasemi.com

United Kingdom
Phone: +44 1793 757700

The Netherlands
Phone: +31 73 640 88 22

Japan
Phone: +81 3 5769 5100

Hong Kong
Phone: +852 2607 4271

Korea
Phone: +82 2 3469 8200

Germany
Phone: +49 7021 805-0

North America
Phone: +1 408 845 8500

Taiwan
Phone: +886 281 786 222

China (Shenzhen)
Phone: +86 755 2981 3669

China (Shanghai)
Phone: +86 21 5424 9058

This publication provides outline information only, which unless agreed by Dialog Semiconductor may not be used, applied or reproduced for any purpose, or be regarded as a representation relating to products. Please refer to Dialog standard supply terms on the company website (www.dialog-semiconductor.com).

© Dialog Semiconductor 2018. All rights reserved. DA9063 2v11