

iW610

Intelligent Synchronous Rectifier Controller with Low V_{CC} Charging Loss for Wide Range of AC/DC Converter Topologies

The **iW610** is an advanced synchronous rectifier (SR) controller with an integrated MOSFET driver. Renesas' proprietary lossless V_{DS} sensing and control technology optimizes the iW610 to work with multiple AC/DC topologies, such as quasi-resonant flyback (QR), discontinuous mode (DCM), continuous mode (CCM) flyback, zero-voltage switching (ZVS) and active clamp flyback (ACF).

The device works with an external power MOSFET to replace the main rectifying diode on the secondary of a flyback converter to achieve high efficiency on the secondary side. This versatility makes the iW610 ideal for the newest high power density AC/DC adapter/charger applications.

With Renesas' innovative and patent-pending V_{CC} charging technology, the iW610 supports both low-side and high-side synchronous rectification without the need for an extra transformer winding. The proprietary technology eliminates excess power dissipation, reducing the iW610 operating temperature and improving efficiency.

The iW610 has the ability to work at output voltages as high as 28V and as low as 3V under all conditions to accommodate a wide array of power supplies. It can sense drain voltages up to 150V, eliminating the need for an external clamping circuit in applications with multi-level output voltages.

Features

- Optimized to support topologies such as QR, DCM, CCM flyback, ZVS and active clamp flyback
- Patent-pending, highly efficient V_{CC} charging technology
- Lowest operating current for zero-standby power.
- Support both high-side and low-side synchronous rectification topologies
- Optimized lossless V_{DS} -based SR sensing and driving control with wide output range
- Supports system output voltages from 3V to 28V in multi-level output voltage and current applications
- High-voltage drain sensing up to 150V with no additional external clamping circuits required
- 6-pin SOT23 package, supports compact system design

Applications

- Compact, high power density AC/DC adapters for tablets, smart phones, laptops, portable devices
- USB Power Delivery (USB PD) chargers
- Low output voltage or high current offline power supplies
- High efficiency auxiliary power supplies in servers, appliances and desktops
- Industrial/home power tools

1. Overview

1.1 Typical Application

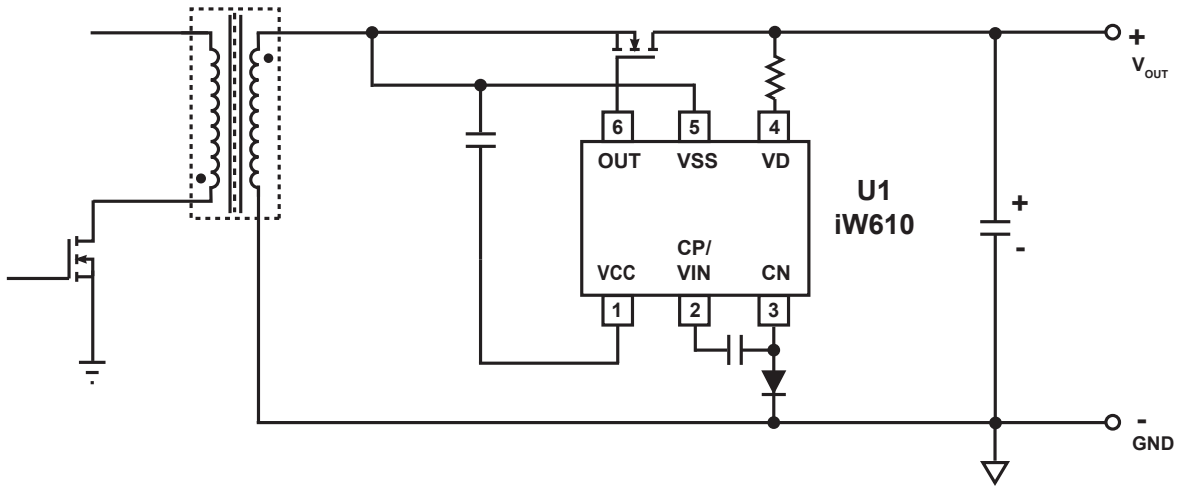

Figure 1. iW610 for High-Side Synchronous Rectification Applications

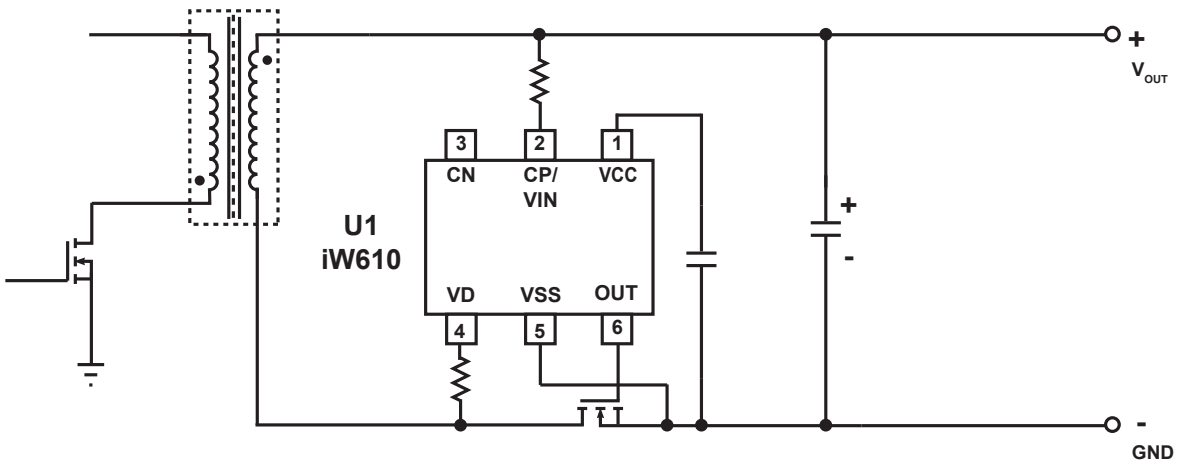

Figure 2. iW610 for Low-Side SR Rectification Applications

2. Pin Information

2.1 Pin Assignments

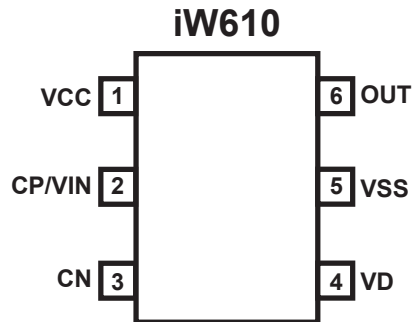

Figure 3. SOT23-6 Package (Top View)

2.2 Pin Descriptions

Pin Number	Pin Name	Type	Description
1	VCC	Power Input	It provides voltage supply for internal logic circuit and SR MOSFET driver. Connect this pin to a capacitor.
2	CP/VIN	Analog Input	High-side SR application: connected to the positive side of external flying capacitor. Low-side SR application: connected to the output capacitor positive side.
3	CN	Analog Input	High-side SR application: connected to the negative side of external flying capacitor. Low-side SR application: connect to VSS pin or leave it open.
4	VD	Analog Input	Synchronous rectifier MOSFET drain voltage sensing and internal VCC charge circuit input.
5	VSS	IC GND	IC Ground.
6	OUT	Analog Output	Synchronous rectifier MOSFET driver.

3. Specifications

3.1 Absolute Maximum Ratings

CAUTION: Do not operate at or near the maximum ratings listed for extended periods of time. Exposure to such conditions can adversely impact product reliability and result in failures not covered by warranty.

Parameter	Symbol	Minimum	Maximum	Unit
OUT pin voltage	V_G	-0.6	10	V
OUT pin peak pull-down current	I_G	-3		A
VCC voltage	V_{VCC}	-0.6	10	V
VD pin voltage (Note 1) (Note 2)	V_{VD}	-1.5	150	V
VD pin peak current	I_{DRAIN}		600	mA
CP/VIN pin voltage	V_{CP}	-0.7	30	V
CN pin voltage	V_{CN}	-30	0.7	V

1. VD pin voltage should not be below -0.6V for more than 500ns
2. VD pin voltage tested using 10 μ s pulse on-time, 20kHz repetitive testing.

3.2 ESD Ratings

ESD Model/Test	Rating	Unit
JEDEC JS-001-2017 (HBM)	$\pm 2,000$	V

3.3 Thermal Specifications

Thermal Resistance (Typical)	θ_{JA} ($^{\circ}$ C/W)
SOT23-6 Package	208

3.4 Recommended Operating Conditions

Parameter	Symbol	Minimum	Maximum	Unit
Maximum junction temperature	T_{JMAX}		150	$^{\circ}$ C
Operating junction temperature	T_{JOPT}	-40	150	$^{\circ}$ C
Storage temperature	T_{STO}	-65	150	$^{\circ}$ C

4. Package Outline Drawings

The package outline drawings are located at the end of this document and are accessible from the Renesas website. The package information is the most current data available and is subject to change without revision of this document.

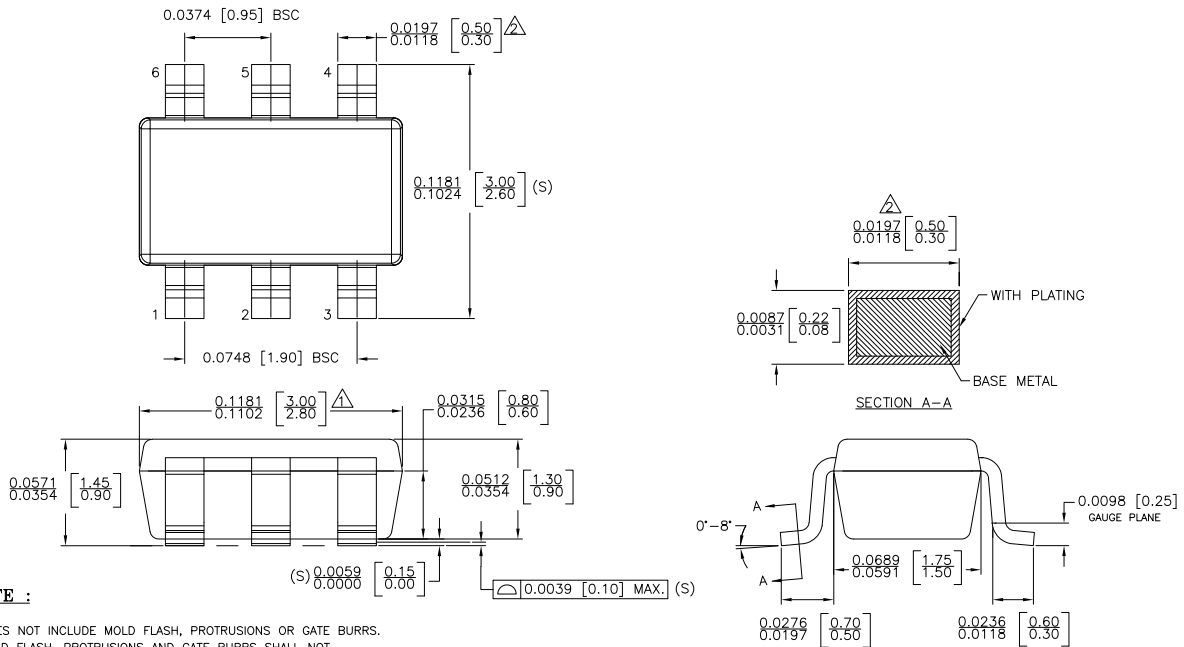

NOTE :

- △ DOES NOT INCLUDE MOLD FLASH, PROTRUSIONS OR GATE BURRS. MOLD FLASH, PROTRUSIONS AND GATE BURRS SHALL NOT EXCEED 0.127 MM PER SIDE.
- △ DOES NOT INCLUDE INTER-LEAD FLASH OR PROTRUSIONS. INTER-LEAD FLASH AND PROTRUSIONS SHALL NOT EXCEED 0.127 MM PER SIDE.
- 3. DIE IS FACING UP FOR MOLD. DIE IS FACING DOWN FOR TRIM/FORM.
- 4. THIS PART IS COMPLIANT WITH EIAJ SPECIFICATION SC74A AND JEDEC SPECIFICATION MO-178AB.
- 5. LEAD SPAN/STAND OFF HEIGHT/COPLANARITY ARE CONSIDERED AS SPECIAL CHARACTERISTIC.(S)
- 6. CONTROLLING DIMENSIONS IN INCHES. [mm]

STATUS: RELEASED	SCALE: DO NOT SCALE
TERMINAL FINISH: 100% Sn or NiPdAu (PPF)	
TITLE: 6 SOT23 PACKAGE OUTLINE	
REV: A	REVISION NOTE: NEW DRAWING
DATE: 02-MAR-2015	

Figure 4. SOT23-6 Package

5. Ordering Information

Part no.	Options			Package	Description
	Minimum on-time	V _{VCC_UPPER} voltage	Sleep Mode Enabled		
iW610-01C	0.4µs	7.5V	No	SOT23-6	Tape & Reel ¹
iW610-05	0.4µs	7.5V	Yes	SOT23-6	Tape & Reel ¹
iW610-06	0.4µs	6V	Yes	SOT23-6	Tape & Reel ¹

1. Tape & Reel packing quantity is 3,000/reel. Minimum packing quantity is 3,000.

IMPORTANT NOTICE AND DISCLAIMER

RENESAS ELECTRONICS CORPORATION AND ITS SUBSIDIARIES (“RENESAS”) PROVIDES TECHNICAL SPECIFICATIONS AND RELIABILITY DATA (INCLUDING DATASHEETS), DESIGN RESOURCES (INCLUDING REFERENCE DESIGNS), APPLICATION OR OTHER DESIGN ADVICE, WEB TOOLS, SAFETY INFORMATION, AND OTHER RESOURCES “AS IS” AND WITH ALL FAULTS, AND DISCLAIMS ALL WARRANTIES, EXPRESS OR IMPLIED, INCLUDING, WITHOUT LIMITATION, ANY IMPLIED WARRANTIES OF MERCHANTABILITY, FITNESS FOR A PARTICULAR PURPOSE, OR NON-INFRINGEMENT OF THIRD PARTY INTELLECTUAL PROPERTY RIGHTS.

These resources are intended for developers who are designing with Renesas products. You are solely responsible for (1) selecting the appropriate products for your application, (2) designing, validating, and testing your application, and (3) ensuring your application meets applicable standards, and any other safety, security, or other requirements. These resources are subject to change without notice. Renesas grants you permission to use these resources only to develop an application that uses Renesas products. Other reproduction or use of these resources is strictly prohibited. No license is granted to any other Renesas intellectual property or to any third-party intellectual property. Renesas disclaims responsibility for, and you will fully indemnify Renesas and its representatives against, any claims, damages, costs, losses, or liabilities arising from your use of these resources. Renesas' products are provided only subject to Renesas' Terms and Conditions of Sale or other applicable terms agreed to in writing. No use of any Renesas resources expands or otherwise alters any applicable warranties or warranty disclaimers for these products.

© 2024 Renesas Electronics Corporation. All rights reserved.

(Disclaimer Rev.1.01 Jan 2024)

Corporate Headquarters

TOYOSU FORESIA, 3-2-24 Toyosu
Koto-ku, Tokyo 135-0061, Japan
www.renesas.com

Contact Information

For further information on a product, technology, the most up-to-date version of a document, or your nearest sales office, please visit:
www.renesas.com/contact-us/

Trademarks

Renesas and the Renesas logo are trademarks of Renesas Electronics Corporation. All trademarks and registered trademarks are the property of their respective owners.