

## RZ Ecosystem Partner Solution RNX-RZFIVE-OSM



### Solution Summary

The RNX-RZFIVE-OSM is a Solderable System on Module (SoM) based on Renesas [RZ/Five](#) 64-bit MPU. It is available in three SoC variants, in compliance with Open Standard Module™ specification OSM Size-M.

### Features/Benefits

- In compliance with Open Standard Module™ specification OSM Size-M, 45x30mm
- Single-core RISC-V AX45MP, 1 GHz
- RAM: 1GiB, DDR4
- eMMC: 4 GiB (optional: up to 64 GiB)
- QSPI NOR Flash (optional)

### Diagrams/Graphics

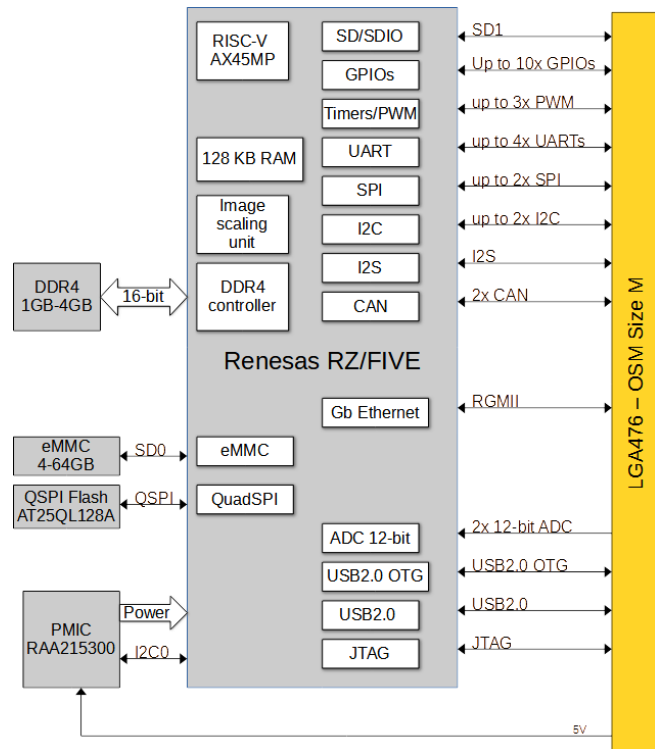
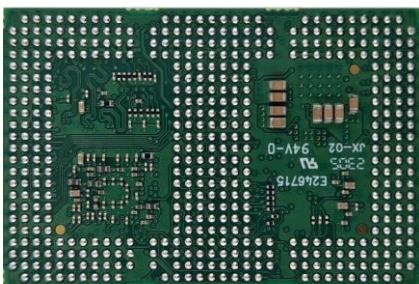

### Target Markets and Applications

- Industrial controls
- Smart home
- Home appliance
- Smart buildings
- Consumer electronics

<https://ronetix.at/product/rnx-rzg2ul-osm-cpu-module-som-with-renesas-rz-g2ul-a3ul-five/>



Ronetix Development Tools GmbH  
Hirschstettner Str. 19/Z110  
1220 Vienna  
Austria

High-performance System on Module (SOM) solutions and  
Hardware development tools for embedded systems.

Experience in embedded systems since 2005.

Ronetix specializes in developing and manufacturing of high-  
performance System on Module (SOM) solutions and JTAG  
emulation tools and debuggers for different based MCUs.