

NOTES:

- 1 ALL DIMENSIONING AND TOLERANCING CONFORM TO ANSI Y14.5M-1994
- 2 DIMENSION IS MEASURED AT THE MAXIMUM SOLDER BALL DIAMETER, PARALLEL TO PRIMARY DATUM -C-
- 3 SEATING PLANE AND PRIMARY DATUM -C- ARE DEFINED BY THE CONTACT POINTS OF THREE OR MORE SOLDER BALLS THAT SUPPORT THE DEVICE WHEN PLACED ON A TOP OF A PLANAR SURFACE.
- 4 ALL DIMENSIONS ARE IN MILLIMETERS

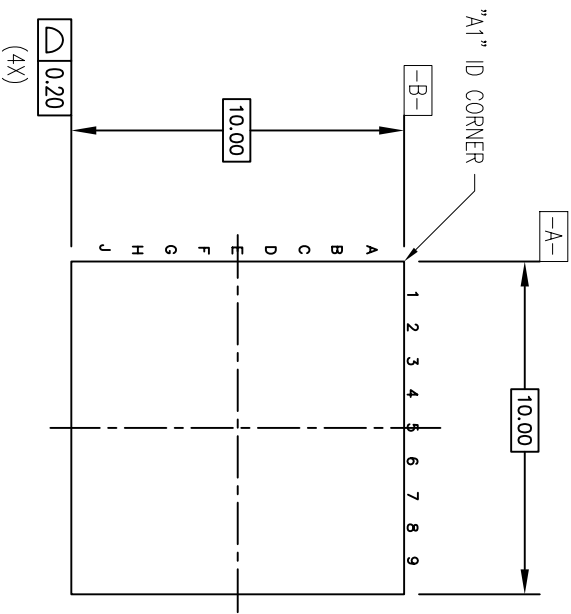

TOP VIEW

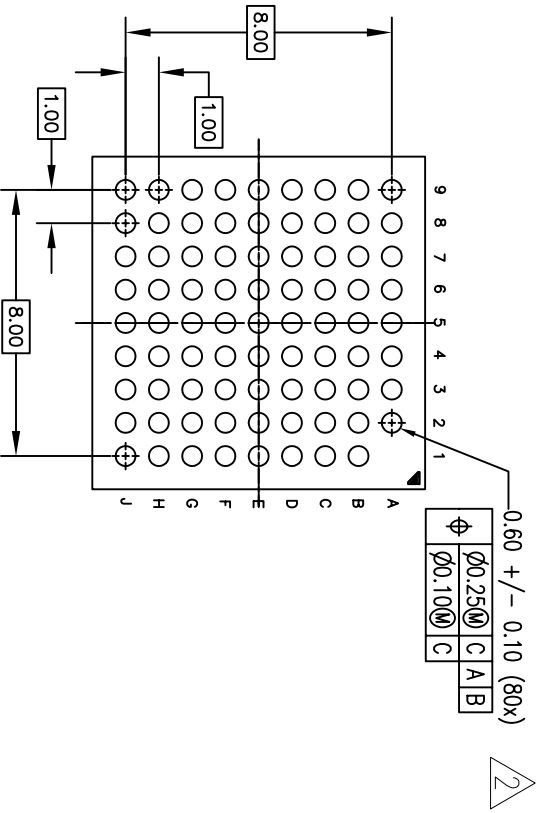

BOTTOM VIEW  
(BALL SIDE VIEW)

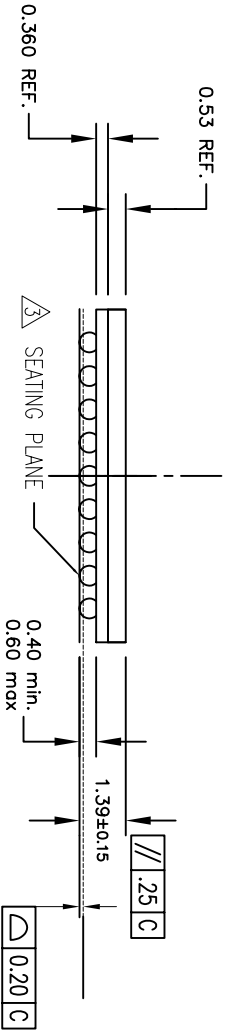

SIDE VIEW

REVISIONS			
REV	DESCRIPTION	DATE	APPROVED
00	INITIAL RELEASE	09/29/11	K. STAHN
01	COMBINE POD & LAND PATTERN	05/15/13	K. STAHN

TOLERANCES UNLESS SPECIFIED  
 DECIMAL ANGULAR  
 XX ± 0.05  
 XXX ±  
 XXXX ±

APPROVALS DATE  
 DRAWN 303 09/29/11  
 CHECKED

**IDT** 6024 Silver Creek Valley Rd  
 San Jose, CA 95138  
 PHONE: (408) 284-8200  
 FAX: (408) 284-2775  
 www.IDT.com

TITLE ASG80 PACKAGE OUTLINE  
 CABGA 10.0 X 10.0mm, 1.0mm pitch

SIZE DRAWING No. PSC-4391 REV 01  
 DO NOT SCALE DRAWING SHEET 1 OF 2

REVISIONS			
REV	DESCRIPTION	DATE	APPROVED
00	INITIAL RELEASE	08/08/12	K. STAHN
01	COMBINE POD & LAND PATTERN	05/15/13	K. STAHN

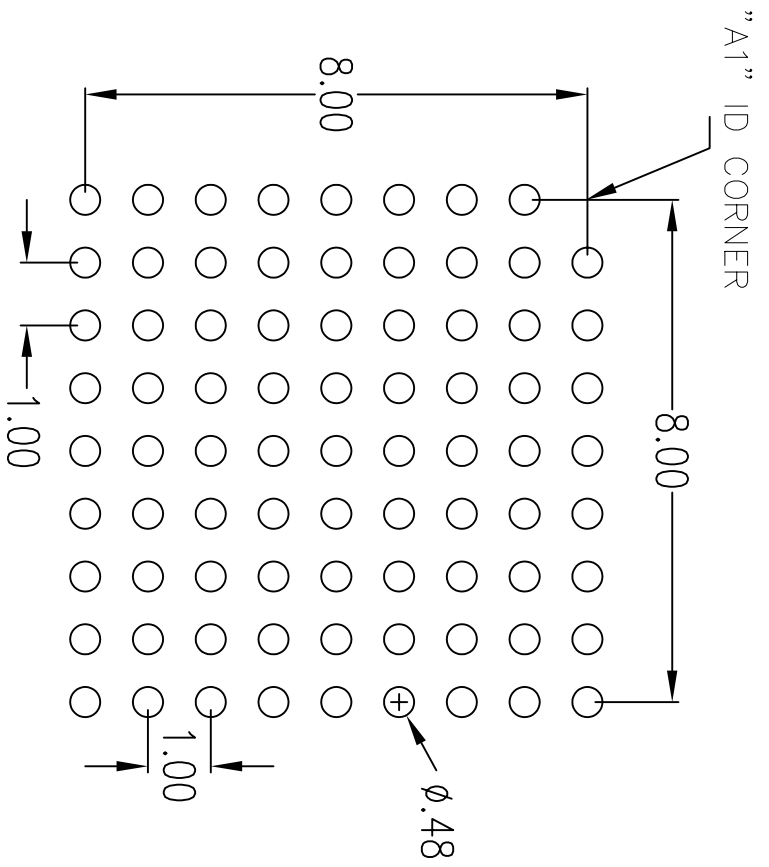

RECOMMENDED LAND PATTERN DIMENSION

TOLERANCES UNLESS SPECIFIED		 <b>6024 Silver Creek Valley Rd</b> San Jose, CA 95138 PHONE: (408) 284-8200 FAX: (408) 284-2775
DECIMAL	ANGULAR	
XX.X	±	<a href="http://www.IDT.com">www.IDT.com</a>
XXXX±		
APPROVALS	DATE	TITLE ASG80 LAND PATTERN
DRAWN <i>RAC</i>	08/09/12	CARGA 10.0 X 10.0mm, 1.0mm pitch
CHECKED		
SIZE	DRAWING No.	REV
C	PSC-4391	01
DO NOT SCALE DRAWING		SHEET 2 OF 2