

NOTES:

1. ALL DIMENSIONS AND TOLERANCES ARE PER ASME Y14.5M-1994.
2. ALL DIMENSIONS ARE IN MILLIMETERS.
3. SEATING PLANE AND PRIMARY DATUM -C- ARE DEFINED BY THE CONTACT POINTS OF THREE OR MORE SOLDER BALLS THAT SUPPORT THE DEVICE WHEN PLACED ON A TOP OF A PLANAR SURFACE.
4. BOTTOM PIN#1 INDICATOR OPTIONAL.

DATE		REVISIONS		
CREATED	REV	DESCRIPTION	AUTHOR	
10/09/13	00	INITIAL RELEASE	JH	
3/31/15	01	CHANGE DIMENSION TOLERANCE	JH	
12/9/16	02	CHANGE BACK SIDE TAPE 0.020 to 0.025	JH	

NOTE: REFER TO DCP FOR OFFICIAL RELEASE DATE

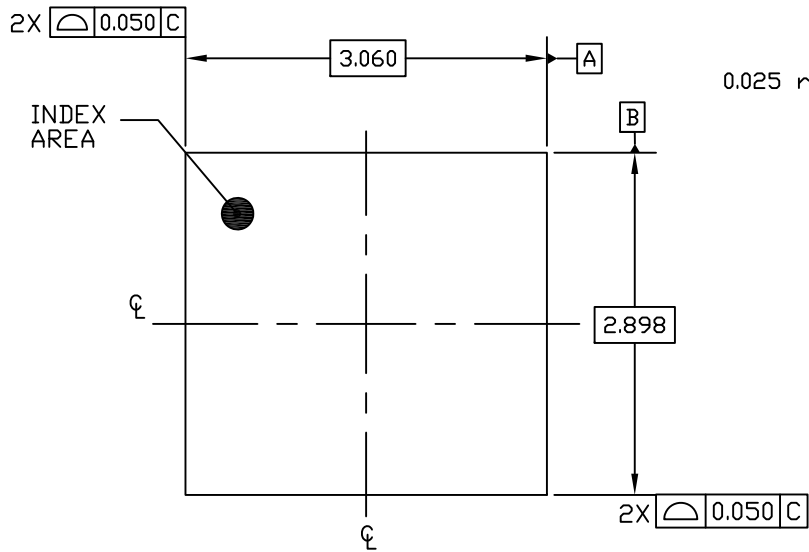

TOP VIEW

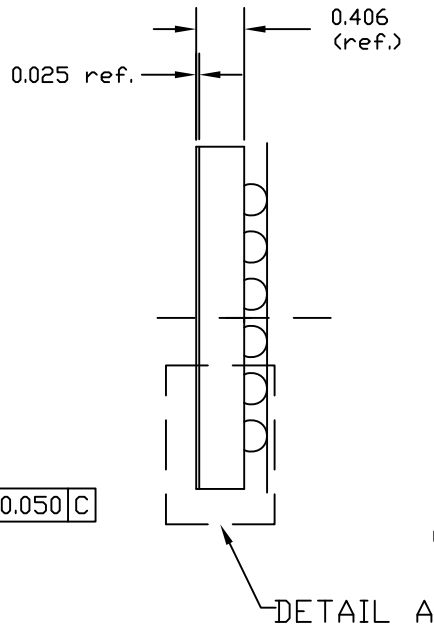

DETAIL A
(ROTATED 90 DEG CW)

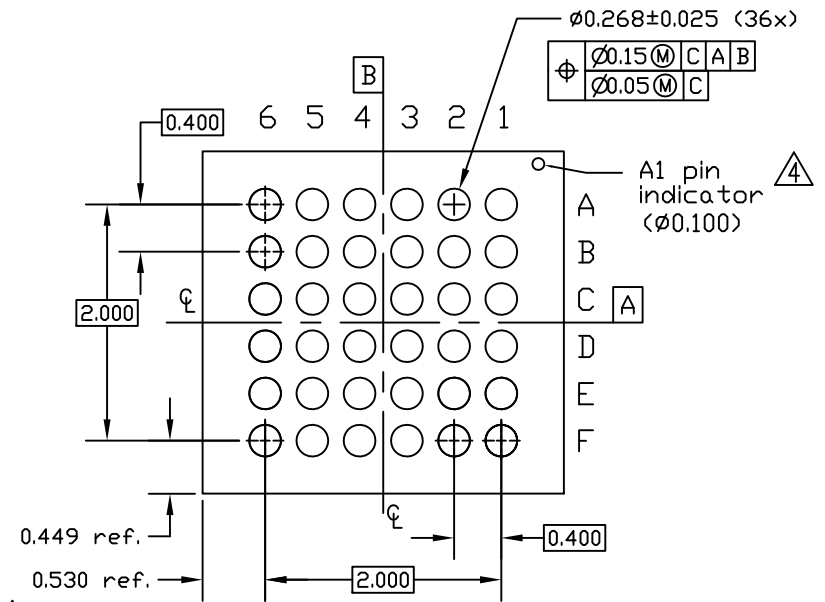

BOTTOM VIEW

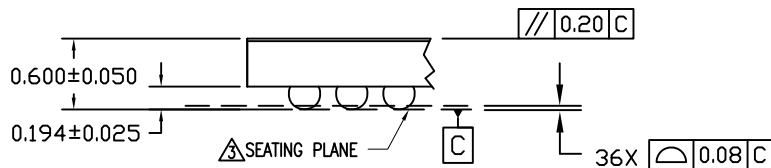

TOLERANCES UNLESS SPECIFIED DECIMAL ANGULAR XX± 0.05 ± XXX± 0.012 ± XXXX±			6024 SILVER CREEK VALLEY ROAD, SAN JOSE, CA 95138 PHONE: (408) 284-8200 FAX: (408) 284-3572
	www.IDT.com		
TITLE AWC36 PACKAGE OUTLINE 3.060 x 2.898mm BODY 0.4mm PITCH DSBGA			
SIZE C	DRAWING No. PSC-4473	REV 02	
DO NOT SCALE DRAWING			SHEET 1 OF 2

DATE CREATED	REVISIONS		
	REV	DESCRIPTION	AUTHOR
10/09/13	00	INITIAL RELEASE	JH
3/31/15	01	CHANGE DIMENSION TOLERANCE	JH
12/9/16	02	CHANGE BACK SIDE TAPE 0.020 to 0.025	JH

NOTE: REFER TO DCP FOR OFFICIAL RELEASE DATE

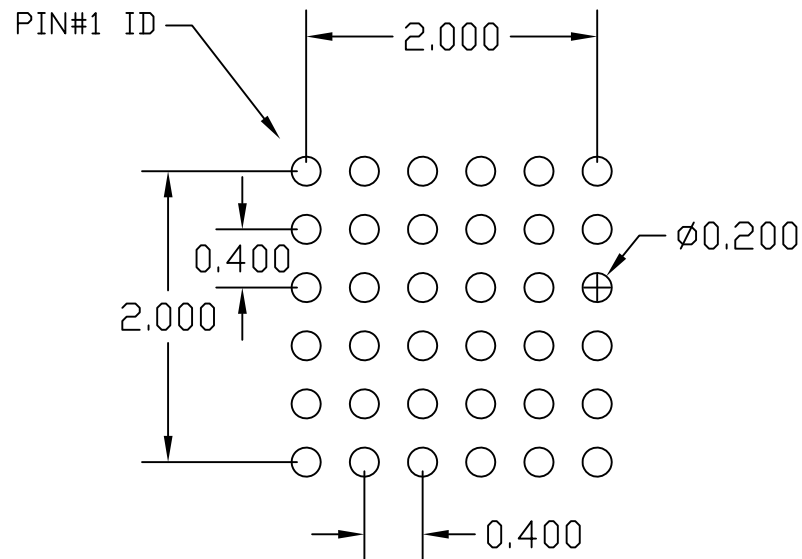

RECOMMENDED LAND PATTERN

NOTE:

- 1) ALL dimensions are in mm, Angles in degrees.
- 2) Top down view, as view on PCB.
- 3) NSMD Land Pattern Assumed.
- 4) Land Pattern Recommendation as per IPC-7351B generic requirement for surface mount design and Land Pattern.

TOLERANCES UNLESS SPECIFIED		 6024 SILVER CREEK VALLEY ROAD, SAN JOSE, CA 95138 PHONE: (408) 284-8200 FAX: (408) 284-3572
DECIMAL	ANGULAR	
XX± 0.05 ±	±	www.IDT.com
XXX± 0.012		
XXXX±		
TITLE AWG36 PACKAGE OUTLINE 3.060 x 2.898mm BODY 0.4mm PITCH DSBGA		
SIZE	DRAWING No.	REV
C	PSC-4473	02
DO NOT SCALE DRAWING		SHEET 2 OF 2