

| REVISIONS | | | |
|-----------|----------------------------|----------|----------|
| REV | DESCRIPTION | DATE | APPROVED |
| 00 | INITIAL RELEASE | 06/12/01 | DX |
| 01 | COMBINE POD & LAND PATTERN | 06/26/13 | KS |

TOP VIEW

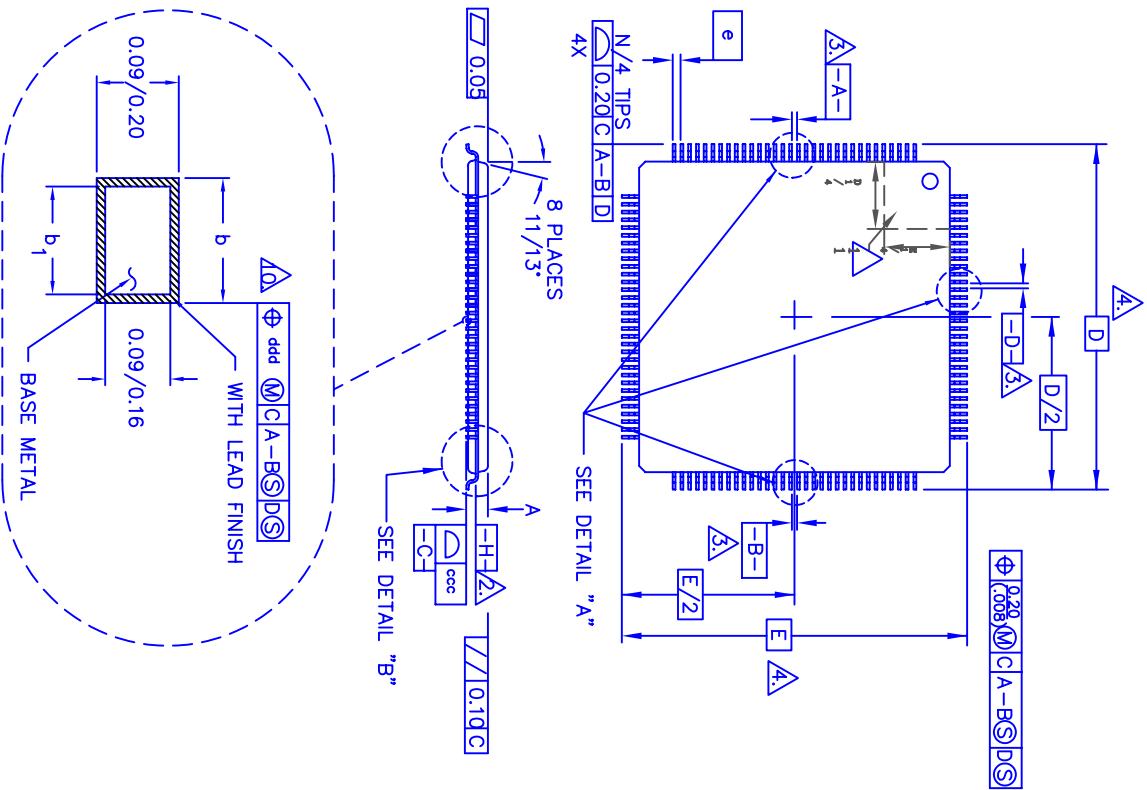

BOTTOM VIEW

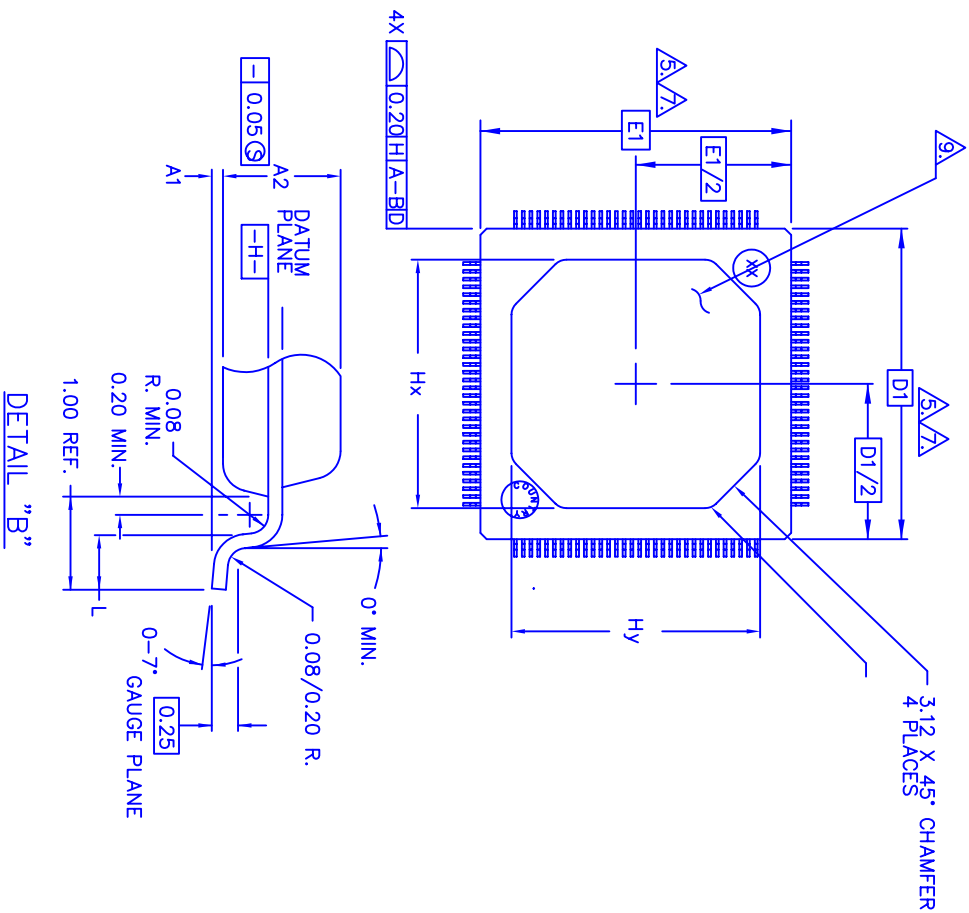

| | | | |
|---|--|--|--|
| UNLESS OTHERWISE SPECIFIED DIMENSIONS ARE IN MILLIMETERS DECIMAL ANGULAR XX ±0.10 XXX ±0.06 XXXX ±0.03 | | APPROVALS DATE DRAWN 03 06/11/01 CHECKED | |
| DD 144 PACKAGE OUTLINE 20 X 20 mm BODY TQFP PowerQuad2 1.00/0.10 mm FORM, 1.40 mm THICK | | DATE 06/11/01 | |
| DRAWING NO. PSC-4103 | | SIZE SCALE REV B N/A 01 | |
| DO NOT SCALE DRAWING SHEET 1 OF 3 | | | |

IDT 6024 SILVER CREEK VALLEY ROAD
 San Jose, CA 95138
 PHONE: (408) 284-8200
 FAX: (408) 492-8674
 www.IDT.com

| REVISIONS | | | |
|-----------|----------------------------|----------|----------|
| REV | DESCRIPTION | DATE | APPROVED |
| 00 | INITIAL RELEASE | 06/12/01 | DX |
| 01 | COMBINE POD & LAND PATTERN | 06/26/13 | KS |

NOTES:

1. ALL DIMENSIONING AND TOLERANCING CONFORM TO ANSI Y14.5-1982.
2. DATUM PLANE [EH] LOCATED AT MOLD PARTING LINE AND COINCIDENT WITH LEAD, WHERE LEAD EXITS PLASTIC BODY AT BOTTOM OF PARTING LINE.
3. DATUMS [AE] AND [ED] TO BE DETERMINED AT CENTERLINE BETWEEN LEADS WHERE LEADS EXIT PLASTIC BODY AT DATUM PLANE [EH].
4. LEADS WHERE LEADS EXIT PLASTIC BODY AT DATUM PLANE [EH] TO BE DETERMINED AT SEATING PLANE [EG].
5. DIMENSIONS D1 AND E1 DO NOT INCLUDE MOLD PROTRUSION. ALLOWABLE MOLD PROTRUSION IS 0.254 MM ON D1 AND E1 DIMENSIONS.
6. "N" IS THE TOTAL NUMBER OF TERMINALS.
7. THESE DIMENSIONS TO BE DETERMINED AT DATUM PLANE [EH].
8. THE TOP OF PACKAGE IS SMALLER THAN THE BOTTOM OF PACKAGE BY 0.15 MILLIMETERS.

ODD LEAD SIDES

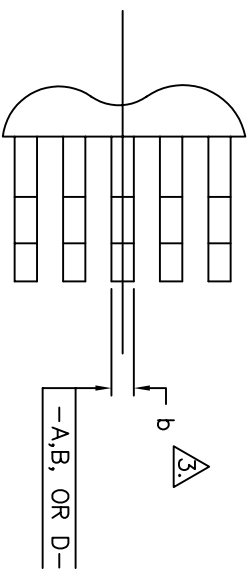

EVEN LEAD SIDES

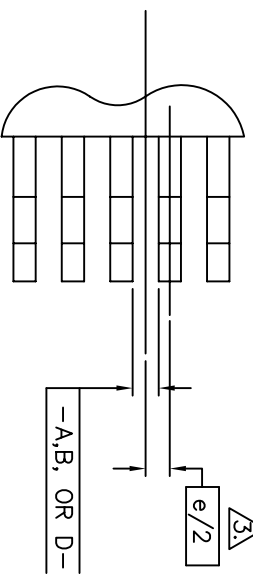

DETAIL "A"

9. DIMENSION b DOES NOT INCLUDE DAMBAR PROTRUSION. ALLOWABLE DAMBAR PROTRUSION SHALL BE 0.08mm TOTAL IN EXCESS OF THE b DIMENSION AT MAXIMUM MATERIAL CONDITION. DAMBAR CANNOT BE LOCATED ON THE LOWER RADIUS OR THE FOOT.
10. DETAIL OF PIN 1 IDENTIFIER IS OPTIONAL BUT MUST BE LOCATED WITHIN THE ZONE INDICATED.
11. ALL DIMENSIONS ARE IN MILLIMETER.
12. THIS OUTLINE CONFORMS TO JEDEC PUBLICATION 95 REGISTRATION MS-026, VARIATION BFB.

| (JEDEC VARIATION) | | | | ALL DIMENSIONS IN MILLIMETERS | |
|-------------------|------------|------------|------------|-------------------------------|--|
| S Y M B O L | MIN. | NOM. | MAX. | N O T E | |
| A | 0.05 | 0.15 | 1.60 | | |
| A1 | 1.35 | 1.40 | 1.45 | | |
| A2 | | | | | |
| D | | | | | |
| D1 | | | | | |
| E1 | | | | | |
| Hx | 15.00 REF. | 15.50 REF. | 16.00 REF. | | |
| Hy | 15.00 REF. | 15.50 REF. | 16.00 REF. | | |
| L | 0.45 | 0.60 | 0.75 | | |
| N | 144 | | | | |
| e | 0.50 BSC. | | | | |
| b | 0.17 | 0.22 | 0.27 | 9 | |
| b1 | 0.17 | 0.20 | 0.23 | | |
| ccc | | | | | |
| ddd | | | | | |

| | | | |
|--|----------|-------------------------------------|----------------|
| UNLESS OTHERWISE SPECIFIED DIMENSIONS ARE IN MILLIMETERS DECIMAL XX ±0.10 XXX ±0.05 XXXX ±0.03 | | SPECIFIED ANGULAR ±1° | |
| APPROVALS | DATE | DD 144 PACKAGE OUTLINE | |
| DRAWN JDS | 06/11/01 | 20 X 20 mm BODY TQFP PowerQuad2 | |
| CHECKED | | 1.00/0.10 mm FORM, 1.40 mm THICK | |
| DRAWING NO. | | PSC-4103 | SIZE SCALE REV |
| | | B | N/A 01 |
| IDT 6024 SILVER CREEK VALLEY ROAD San Jose, CA 95138 PHONE: (408) 284-8200 FAX: (408) 492-8674 | | www.IDT.com DO NOT SCALE DRAWING | |
| SHEET 2 OF 3 | | | |

| REVISIONS | | | |
|-----------|----------------------------|----------|----------|
| REV | DESCRIPTION | DATE | APPROVED |
| 00 | INITIAL RELEASE | 06/12/01 | DX |
| 01 | COMBINE POD & LAND PATTERN | 08/28/13 | KS |

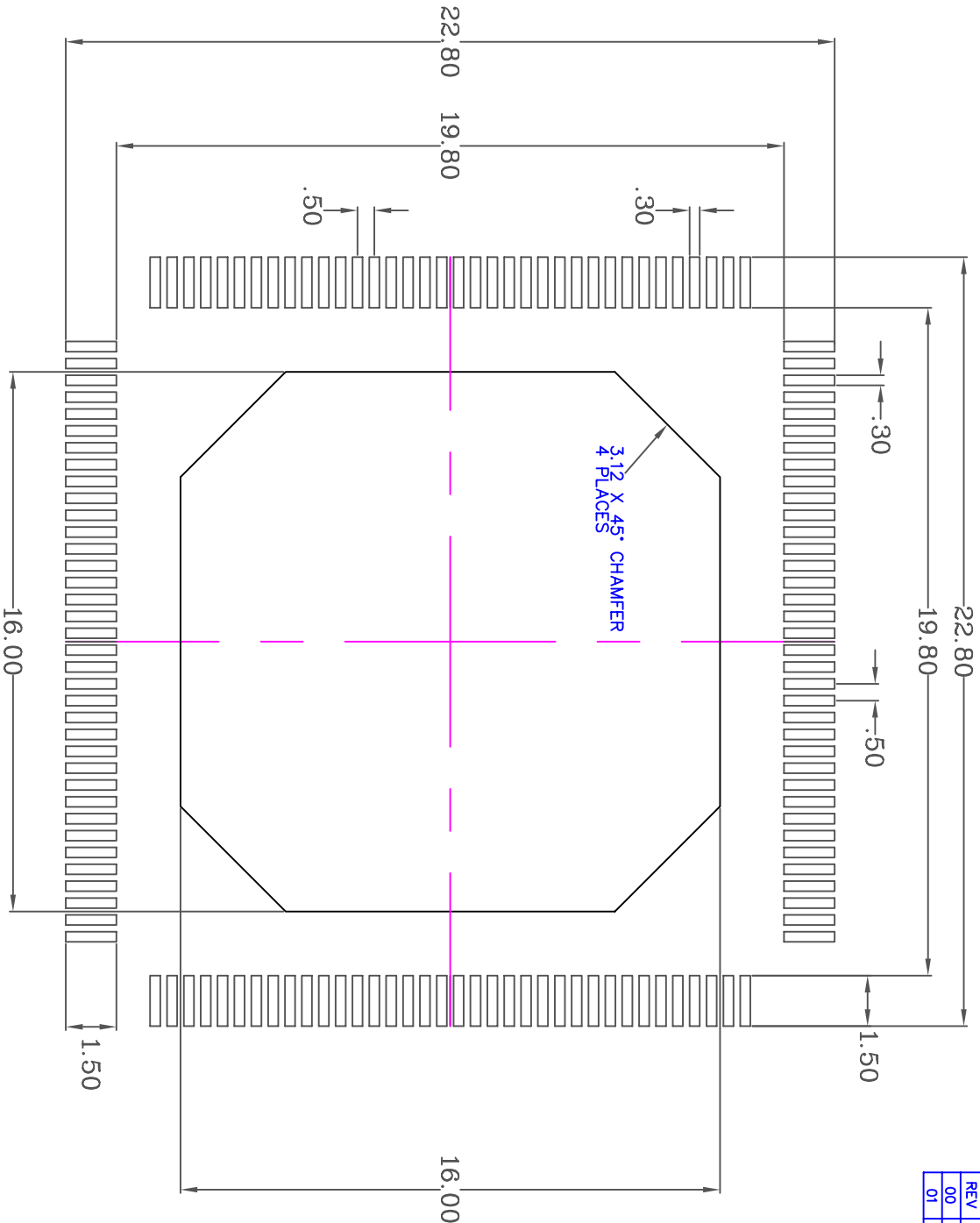

RECOMMENDED FOOT PRINT DIMENSION

- NOTES:**
1. ALL DIMENSION ARE IN mm. ANGLES IN DEGREES.
 2. TOP DOWN VIEW. AS VIEWED ON PCB.
 3. LAND PATTERN IN BLACK. NSMD PATTERN ASSUMED.
 4. LAND PATTERN RECOMMENDATION PER IPC-7351B LP CALCULATOR.

| | | | | | |
|---|--|--|--|-------------------------------------|--|
| <small>UNLESS OTHERWISE SPECIFIED DIMENSIONS ARE IN MILLIMETERS DECIMAL XX ±0.10 XXX ±0.05 XXXX ±0.03</small> | | <small>APPROVALS</small> | | <small>DATE</small> | |
| <small>ANGULAR ° ±</small> | | <small>DRAWN</small> | | <small>08/11/01</small> | |
| <small>CHECKED</small> | | <small>DD 144 PACKAGE OUTLINE 20 X 20 mm BODY TQFP PowerQuad2 1.00/0.10 mm FORM, 1.40 mm THICK</small> | | <small>DRAWING No.</small> | |
| <small>WWW.IDT.COM</small> | | <small>PSC-4103</small> | | <small>SIZE SCALE REV</small> | |
| <small>6024 SILVER CREEK VALLEY ROAD San Jose, CA 95138 PHONE: (408) 284-8200 FAX: (408) 492-8674</small> | | <small>B N/A 01</small> | | <small>DO NOT SCALE DRAWING</small> | |
| <small>DO NOT SCALE DRAWING</small> | | <small>SHEET 3 OF 3</small> | | | |