

REVISIONS		DESCRIPTION	DATE	APPROVED
DCN	REV	INITIAL RELEASE	08/20/96	T. VU
29253	00	ADD 'DR' PACKAGE OPTION	09/20/98	T. VU
61476	01	ADD 'DR' PACKAGE OPTION	01/30/99	T. VU
61829	02	ADD 'DR' PACKAGE OPTION		

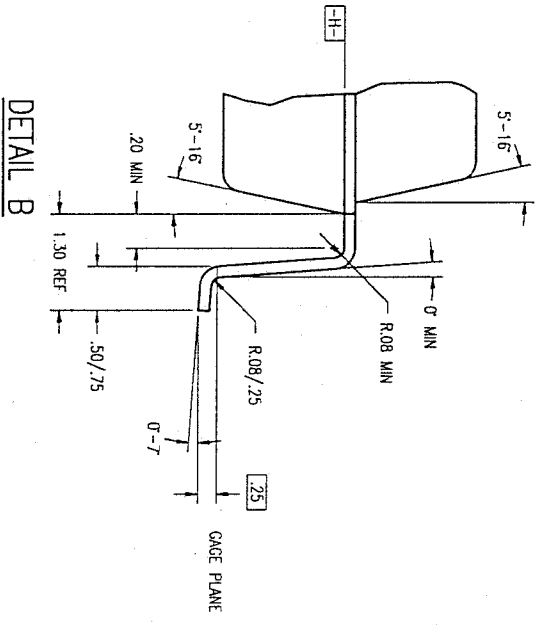

FEB 08 1999

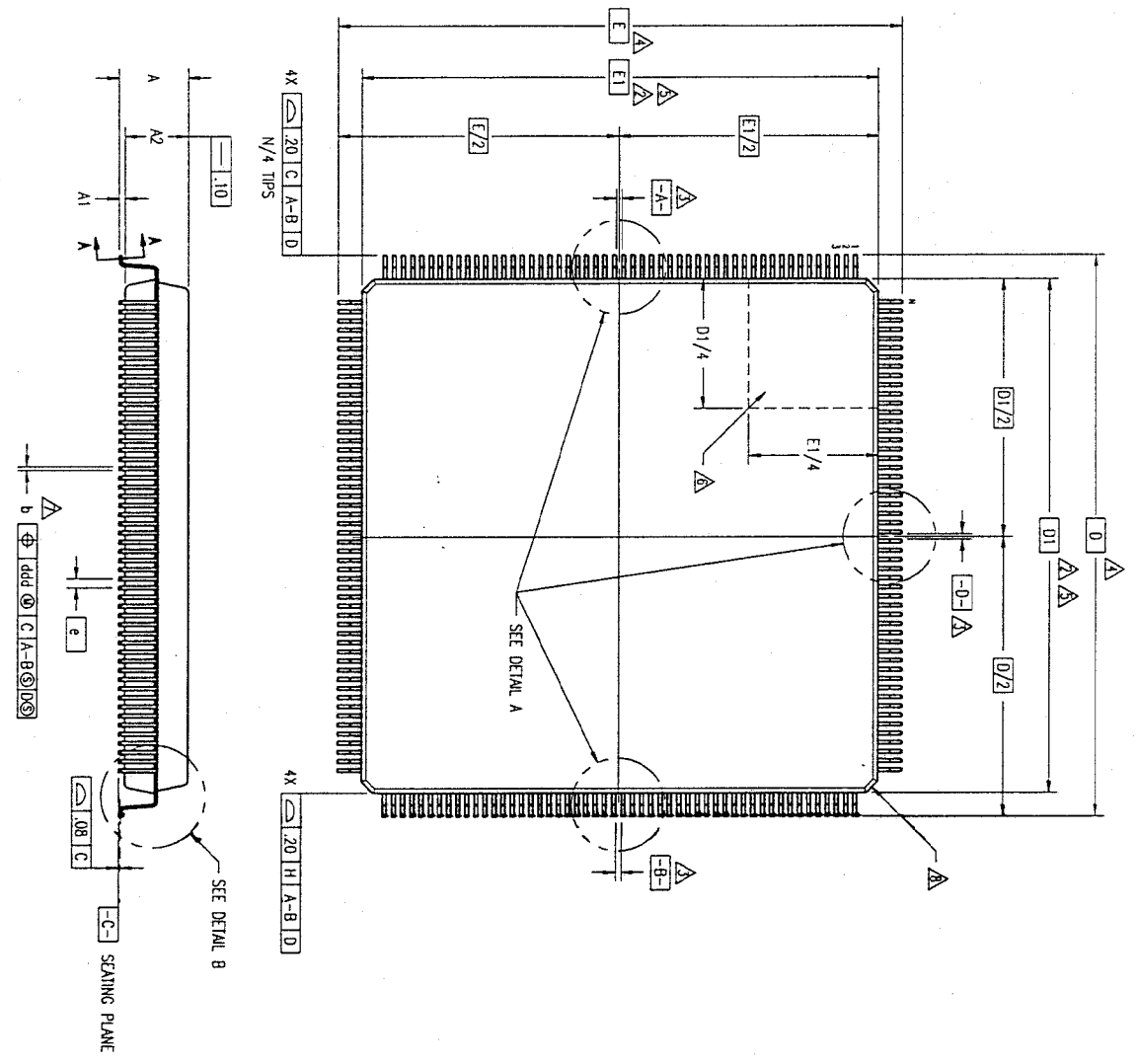
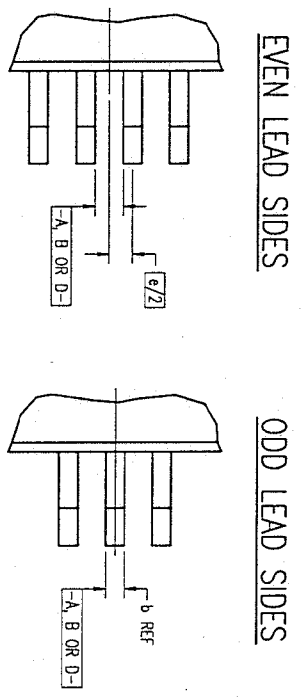
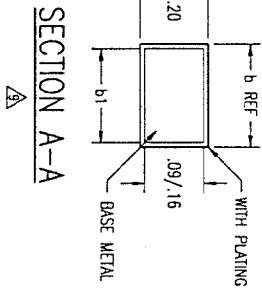

TOLERANCES UNLESS SPECIFIED		<p>Integrated Device Technology, Inc. 2975 Stender Way, Santa Clara, CA 95054 PHONE: (408) 727-6116 FAX: (408) 482-8674 TRK: 910-318-2020</p>
DECIMAL ±		
ANGULAR XXX±		
XXXX±		
APPROVALS	DATE	TITLE
BRANK JV	09/20/98	05/0H/DR PACKAGE OUTLINE
CHECKED		28.0 X 28.0 X 3.4 mm PQFP
		1.30/25 MIN FORM
SIZE	DRAWING No.	REV
C	PSC-4059	02
DO NOT SCALE DRAWING		
SHEET 1 OF 2		

REVISIONS				
DCN	REV	DESCRIPTION	DATE	APPROVED
29253	00	INITIAL RELEASE	08/20/96	T. WU
61476	01	ADD 'DR' PACKAGE OPTION	09/20/98	T. WU
61829	02	ADD 'DR' PACKAGE OPTION	01/30/99	T. WU

LAND PATTERN DIMENSIONS

SYMBOL	JEDEC VARIATION			N D T E
	FA-1			
	MIN	NOM	MAX	
A	-	-	4.10	
A1	.25	-	-	
A2	3.20	3.40	3.60	
D	30.60 BSC			4
D1	28.00 BSC			5.2
E	30.60 BSC			4
E1	28.00 BSC			5.2
N	208			
e	.50 BSC			
b	.17	-	.27	7
b1	.17	.20	.23	
ddd	-	-	.08	

NOTES:

- ALL DIMENSIONING AND TOLERANCING CONFORM TO ASME Y14.5M-1994
- TOP PACKAGE MAY BE SMALLER THAN BOTTOM PACKAGE BY .15 mm
- DATUMS [A-B] AND [D] TO BE DETERMINED AT DATUM PLANE [H]
- DIMENSIONS D AND E ARE TO BE DETERMINED AT SEATING PLANE [C]
- DIMENSIONS D1 AND E1 DO NOT INCLUDE MOLD PROTRUSION. ALLOWABLE MOLD PROTRUSION IS .25 mm PER SIDE. D1 AND E1 ARE BODY SIZE DIMENSIONS INCLUDING MOLD MISMATCH
- DETAIL OF PIN 1 IDENTIFIER IS OPTIONAL BUT MUST BE LOCATED WITHIN THE ZONE INDICATED
- DIMENSION b DOES NOT INCLUDE DAMBAR PROTRUSION. ALLOWABLE DAMBAR PROTRUSION IS .08 mm IN EXCESS OF THE b DIMENSION AT MAXIMUM MATERIAL CONDITION. DAMBAR CANNOT BE LOCATED ON THE LOWER RADIUS OR THE FOOT.
- EXACT SHAPE OF EACH CORNER IS OPTIONAL
- THESE DIMENSIONS APPLY TO THE FLAT SECTION OF THE LEAD BETWEEN .10 AND .25 mm FROM THE LEAD TIP
- ALL DIMENSIONS ARE IN MILLIMETERS
- THIS OUTLINE CONFORMS TO JEDEC PUBLICATION 95 REGISTRATION MO-143, VARIATION FA-1

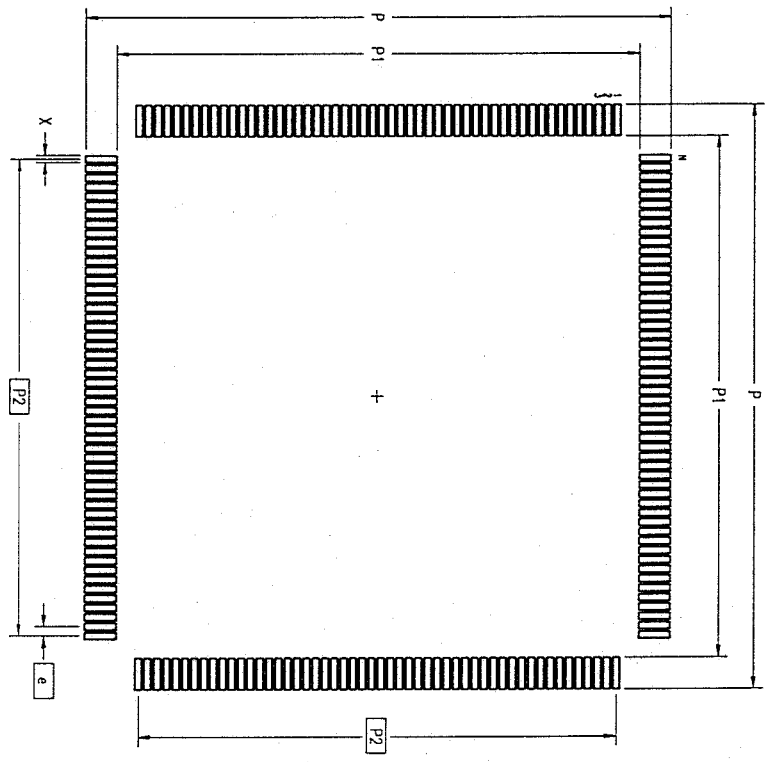

	MIN	MAX
P	31.20	31.40
P1	27.80	28.00
P2	25.50 BSC	
X	.30	.40
e	.50 BSC	
N	208	

FEB 08 1999

TOLERANCES UNLESS SPECIFIED		Integrated Device Technology, Inc.	
DECIMAL	ANGULAR	2975 Sander Way, Santa Clara, CA 95054	
XX.X	X	PHONE: (408) 727-6116	
XXXX		FAX: (408) 482-8674	
APPROVALS		DATE	
DRAWN BY	DATE		
CHECKED			
TITLE		DS/DR/DR PACKAGE OUTLINE	
		28.0 X 28.0 X 3.4 mm PQFP	
		1.30/.25 MIN FORM	
SIZE	DRAWING NO.	PSC-4059	
C			
DO NOT SCALE DRAWING	SHEET 2 OF 2		