

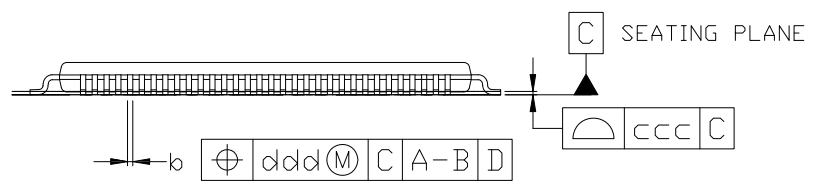

REVISIONS			
REV	DESCRIPTION	DATE	APPROVED
00	INITIAL RELEASE	3/2/11	JG
01	COMBINE POD & LAND PATTERN	6/24/13	KS
02	CORRECT LAND PATTERN	6/10/15	JH

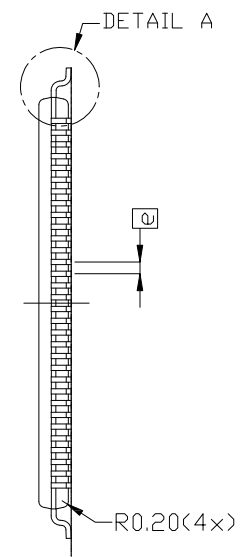
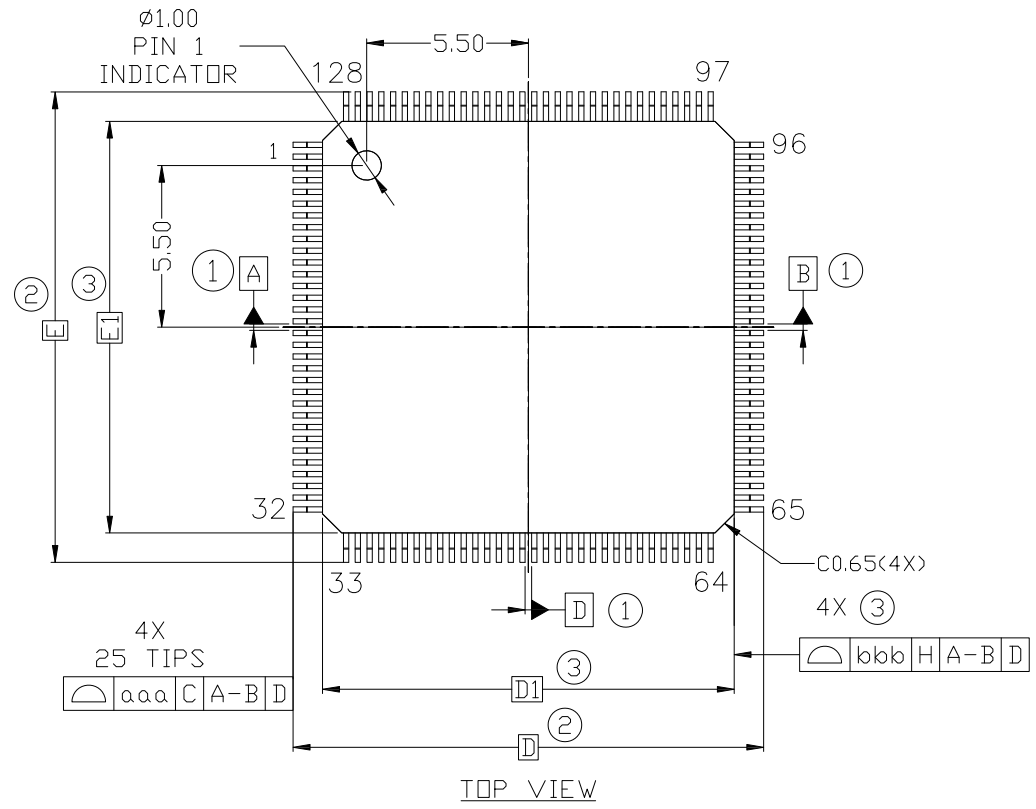

TOLERANCES UNLESS SPECIFIED		 <b>www.IDT.com</b>	6024 Silver Creek Valley Road	
DECIMAL	ANGULAR		San Jose CA 95138	
X±	±1'		PHONE: (408) 284-8200	
XX±			FAX: (408) 284-8591	
XXX±				
APPROVALS	DATE	TITLE EM/EMG128 PACKAGE OUTLINE		
DRAWN JG	3/2/11	14.0 x 14.0 x 1.0 mm BODY		
CHECKED		0.40 mm PITCH TQFP		
		SIZE	DRAWING No.	REV
		C	PSC-4346	02
DO NOT SCALE DRAWING				SHEET 1 OF 3

SYMBOL	Min.	Nom.	Max.
A	-	-	1.20
A1	0.05	-	0.15
A2	0.95	1.00	1.05
b	0.13	0.18	0.23
b1	0.13	0.16	0.19
D	16.00 BSC		
D1	14.00 BSC		
e	0.40 BSC		
E	16.00 BSC		
E1	14.00 BSC		
$\theta$	0°	3.5°	7°
$\theta 1$	0°	-	-
SYMBOL	Min.	Nom.	Max.
$\theta 2$	11°	12°	13°
$\theta 3$	11°	12°	13°
c	0.09	-	0.20
c1	0.09	-	0.16
L	0.45	0.60	0.75
L1	1.00 REF		
R1	0.08	-	-
R2	0.08	-	0.20
REF	TOLERANCES OF FORM & POSITION		
aaa	0.20		
bbb	0.20		
ccc	0.08		
ddd	0.07		
N	128		

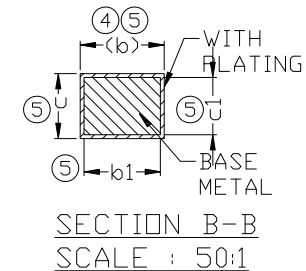
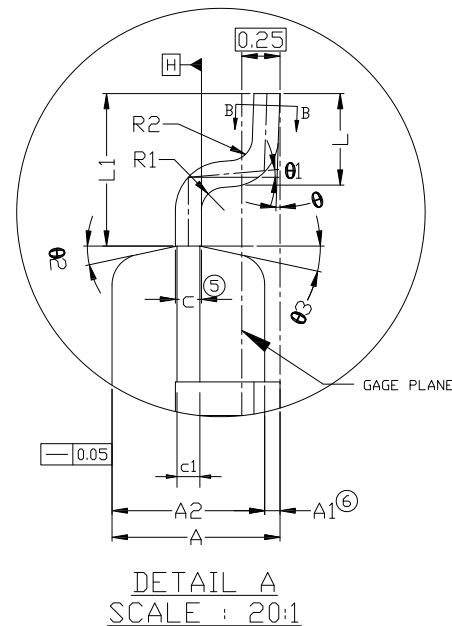

REVISIONS			
REV	DESCRIPTION	DATE	APPROVED
00	INITIAL RELEASE	3/2/11	JG
01	COMBINE POD & LAND PATTERN	6/24/13	KS
02	CORRECT LAND PATTERN	6/10/15	JH

NOTE :

- ① DATUM A-B AND D TO DETERMINE AT DATUM PLANE H.
- ② TO BE DETERMINED AT SEATING DATUM PLAN C.
- ③ DIMENSION D1 AND E1 DO NOT INCLUDE MOLD PROTRUSIONS. ALLOWABLE PROTRUSION IS 0.25 mm PER SIDE. S1 AND E1 ARE MAXIMUM PLASTIC BODY SIZE DIMENSION INCLUDING MOLD MISMATCH.
- ④ DIMENSION b DOSE NOT INCLUDE DAMBAR PROTRUSION. ALLOWABLE DAMBAR PROTRUSION SHALL NOT CAUSE THE LEAD WIDTH TO EXCEED THE MAXIMUM b DIMENSION BY MORE THAN 0.08 mm. DAMBAR CANNOT BE LOCATED ON THE LOWER RADIUS OR THE FOOT. MINIMUM SPACE BETWEEN PROTRUSION AND ADJACENT LEAD IS 0.07 mm FOR 0.4mm AND 0.5 mm PITCH PACKAGE.
- ⑤ THESE DIMENSIONS APPLY TO THE FLAT SECTION OF THE BETWEEN 0.10 mm AND 0.25 mm FROM THE LEAD TIP.
- ⑥ A1 IS THE DEFINED AS THE DISTANCE FROM THE SEATING PLANE TO THE LOWEST POINT ON THE PACKAGE BODY.
- 7 PACKAGE DIMENSIONS CONFORM TO JEDEC MS-026 Rev.D

TOLERANCES UNLESS SPECIFIED		 <b>www.IDT.com</b>	6024 Silver Creek Valley Road San Jose CA 95138 PHONE: (408) 284-8200 FAX: (408) 284-8591	
DECIMAL	ANGULAR			
X±	±1'			
XX±				
XXX±				
APPROVALS	DATE	TITLE EM/EMG128 PACKAGE OUTLINE		
DRAWN JG	3/2/11	14.0 x 14.0 x 1.0 mm BODY		
CHECKED		0.40 mm PITCH TQFP		
		SIZE	DRAWING No.	REV
		C	PSC-4346	02
DO NOT SCALE DRAWING				SHEET 2 OF 3

REVISIONS			
REV	DESCRIPTION	DATE	APPROVED
00	INITIAL RELEASE	3/2/11	JG
01	COMBINE POD & LAND PATTERN	6/24/13	KS
02	CORRECT LAND PATTERN	6/10/15	JH

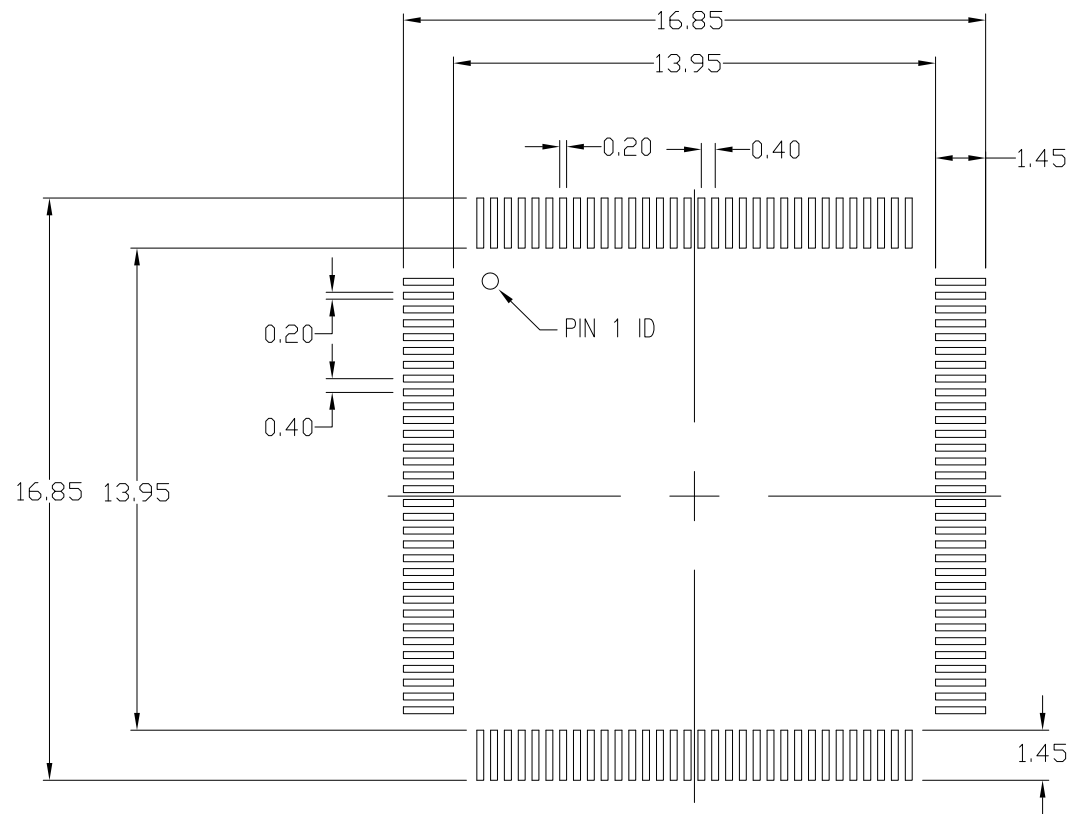

**RECOMMENDED LAND PATTERN DIMENSION**

**NOTES:**

1. ALL DIMENSIONS ARE IN MM, ANGLES IN DEGREES.
2. TOP DOWN VIEW, AS VIEWED ON PCB.
3. LAND PATTERN IN BLACK, NSMD PATTERN ASSUMED.
4. LAND PATTERN RECOMMENDATION PER IPC-7351B LP CALCULATOR.

TOLERANCES UNLESS SPECIFIED		 <b>IDT™</b> www.IDT.com	6024 Silver Creek Valley Road San Jose CA 95138 PHONE: (408) 284-8200 FAX: (408) 284-8591	
DECIMAL	ANGULAR			
X±	±1°			
XX±				
XXX±				
APPROVALS	DATE	TITLE EM/EMG128 PACKAGE OUTLINE		
DRAWN JG	3/2/11	14.0 x 14.0 x 1.0 mm BODY		
CHECKED		0.40 mm PITCH TQFP		
		SIZE	DRAWING No.	REV
		C	PSC-4346	02
DO NOT SCALE DRAWING				SHEET 3 OF 3