

Plastic Packages for Integrated Circuits

Package Outline Drawing

Q44.10x10A

44 LEAD THIN PLASTIC QUAD FLATPACK PACKAGE WITH EXPOSED PAD (EP-TQFP)

Rev 2, 12/10

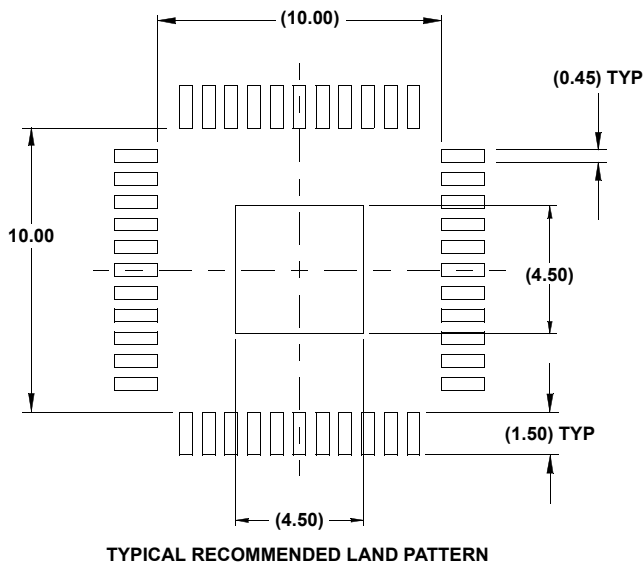
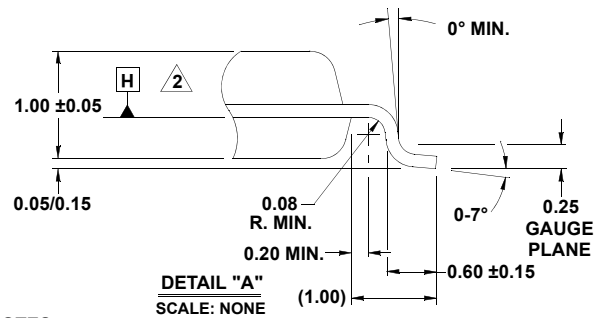
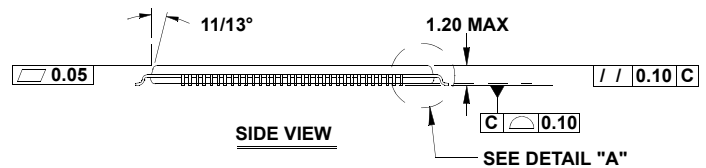
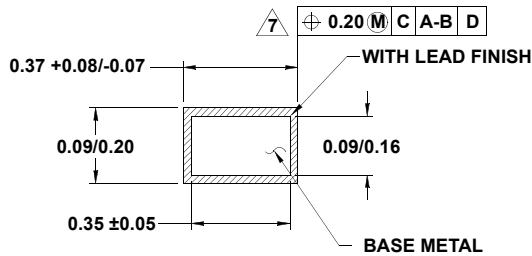
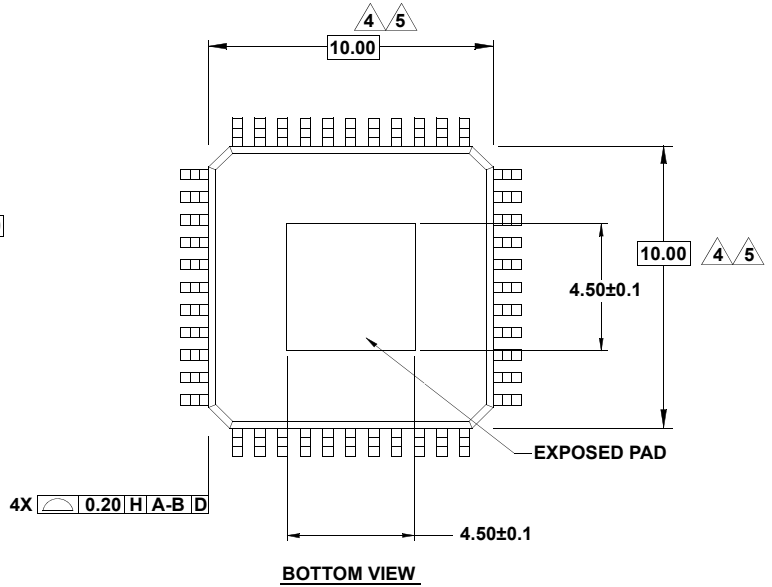
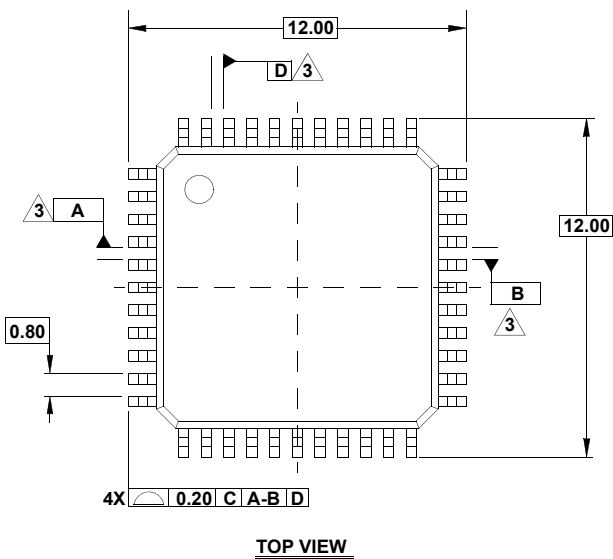

NOTES:

- All dimensioning and tolerancing conform to ANSI Y14.5-1982.
- Datum plane **H** located at mold parting line and coincident with lead, where lead exits plastic body at bottom of parting line.
- Datums **A-B** and **D** to be determined at centerline between leads where leads exit plastic body at datum plane **H**.
- Dimensions **D1** and **E1** do not include mold protrusion. Allowable mold protrusion is 0.254mm on **D1** and **E1** dimensions.
- These dimensions to be determined at datum plane **H**.
- Package top dimensions are smaller than bottom dimensions and top of package will not overhang bottom of package.
- Dimension **b** does not include dambar protrusion. Allowable dambar protrusion shall be 0.08mm total in excess of the **b** dimension at maximum material condition. Dambar cannot be located on the lower radius or the foot.
- Controlling dimension: millimeter.
- This outline conforms to JEDEC publication 95 registration MS-026, variation ACB.
- Dimensions in () are for reference only.
- The corners of the exposed heatspreader may appear different due to the presence of the tiebars.