

SLG47011V DIP Adapter

This user guide is intended to familiarize new users with the SLG47011V DIP Adapter. It consists of the description of the board, lists its features, shows top and bottom views, as well as the board schematic.

Contents

1. Description 1

2. Features 1

3. Top View 2

4. Bottom View 2

5. Board Schematic 3

6. Revision History 3

1. Description

The GreenPAK DIP Adapter is a small PCB that lets you adapt STQFN packages into a DIP footprint. This board can speed up your design prototyping and testing. This small board 0.43x1.84 inch uses 20 pins DIP footprint with 0.3-inch width. You can also use this adapter for prototyping by making the STQFN-16 package compatible with solder-free breadboards.

2. Features

- Low cost
- Simplifies prototyping of SMT ICs
- Optional V_{DD} LED indicator
- Decoupling capacitor included
- Optional I²C pull-up resistors

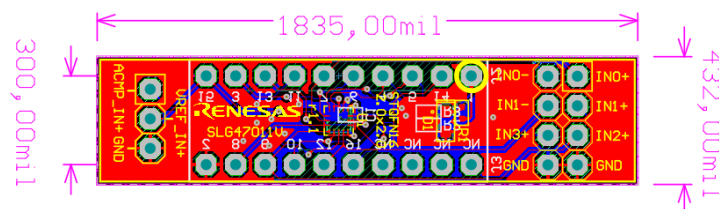

3. Top View

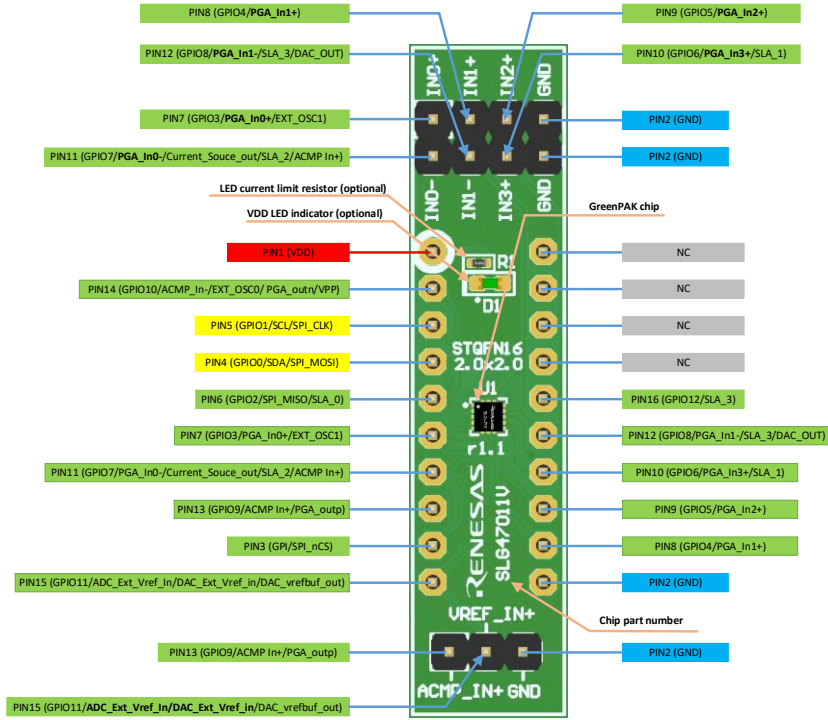

4. Bottom View

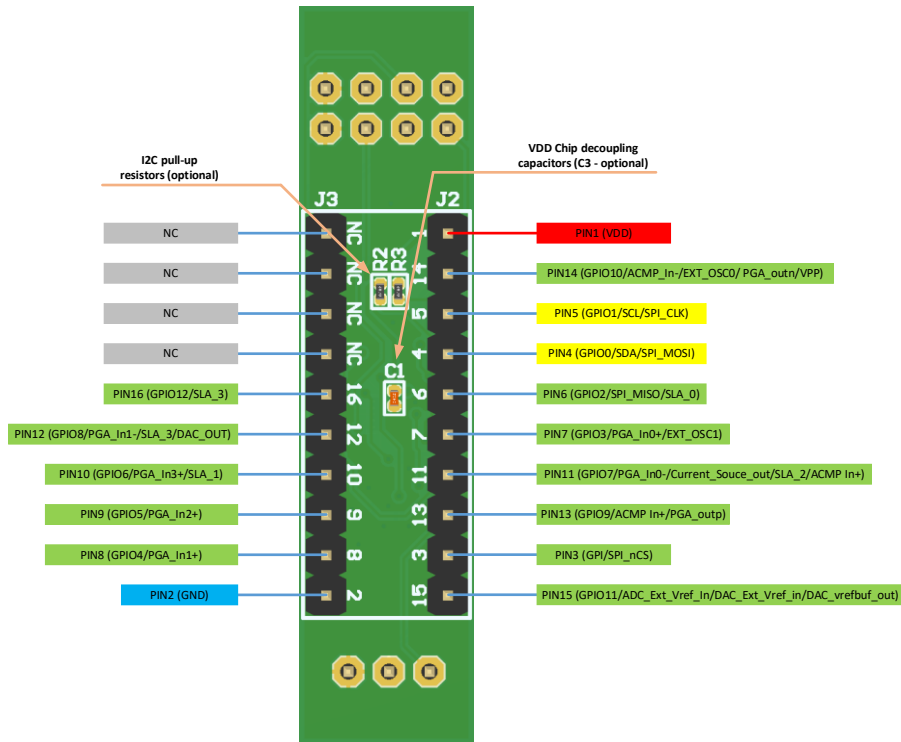

5. Board Schematic

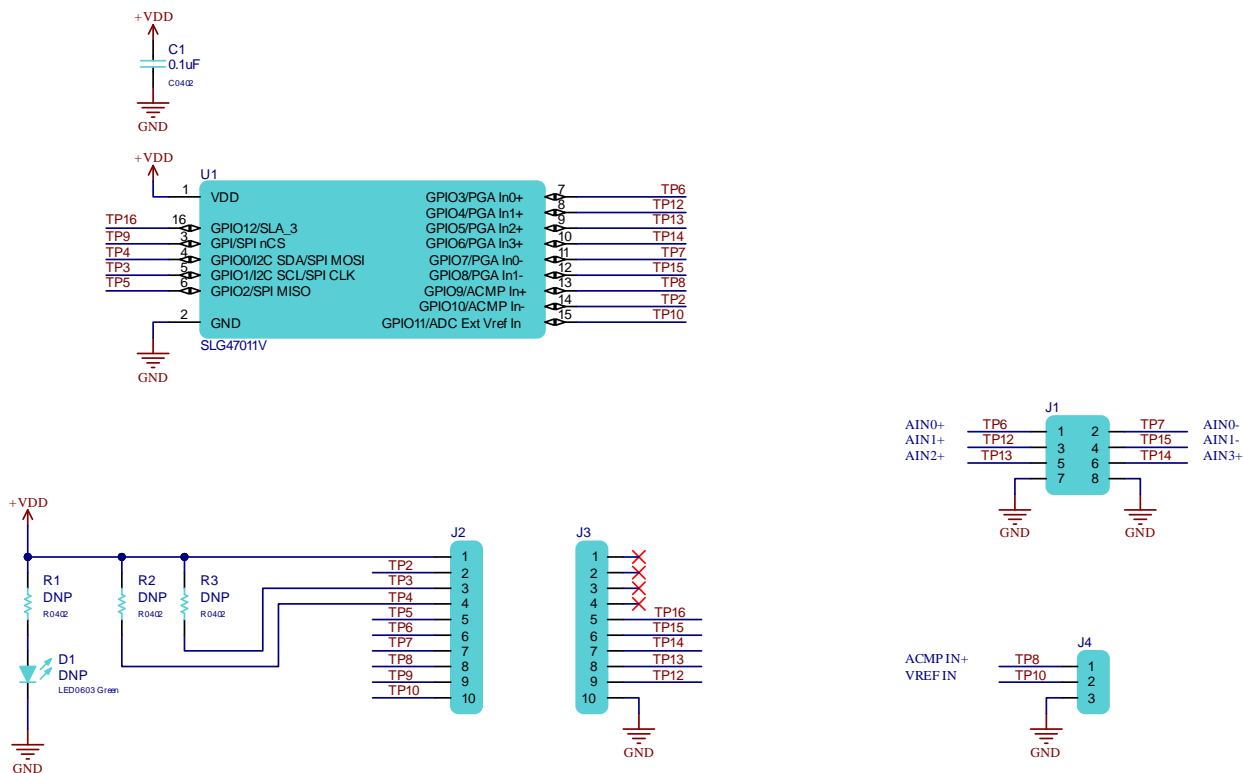

6. Ordering Information

Part Number	Description
SLG47011V-DIP	SLG47011V DIP Adapter

7. Revision History

Revision	Date	Description
1.02	Sep 30, 2024	Corrected document title
1.01	Oct 24, 2023	Added Ordering Information
1.00	Sep 22, 2023	Initial release.