

ZCU670 Multicast Boundary Clock Performance

Introduction

This report shows the results of Multicast Boundary Clock testing with the ZCU670 platform. Tests results are compared to the ITU-T G.8273.2 Full Time Support Standard.

Contents

1. Overview	3
2. Results Summary	3
3. Test Configuration	3
4. Standalone Tests (ts2phc, ptp4l, synced)	4
4.1 G.8273.2: Noise Generation	4
4.1.1 PTP Measurements	4
4.1.2 1PPS Measurements	12
4.2 G.8273.2: Holdover	20
4.2.1 PTP Measurements	20
4.2.2 1PPS Measurements	24
4.3 G.8273.2: SyncE to PTP Noise Transfer	26
4.3.1 PTP Measurements	26
4.4 G.8273.2: SyncE to 1PPS Noise Transfer	29
4.4.1 1PPS Measurements	29
4.5 G.8273.2: PTP to PTP Noise Transfer	32
4.5.1 PTP Measurements	32
4.6 G.8273.2: PTP to 1PPS Noise Transfer	35
4.6.1 1PPS Measurements	35
4.7 G.8273.2: SyncE Transient	38
4.7.1 PTP Measurements	38
4.7.2 1PPS Measurements	41
4.8 G.8273.2: G.8271.1 Reference Point C PDV	43
4.8.1 PTP Measurements	43
4.8.2 1PPS Measurements	44
5. External Servo Tests (pcm4l, ptp4l, synced)	46
5.1 G.8273.2: Noise Generation	46
5.1.1 PTP Measurements	46
5.1.2 1PPS Measurements	54
5.2 G.8273.2: Holdover	62
5.2.1 PTP Measurements	62
5.2.2 1PPS Measurements	66
5.3 G.8273.2: SyncE to PTP Noise Transfer	68
5.3.1 PTP Measurements	68
5.4 G8273.2: SyncE to 1PPS Noise Transfer	71
5.4.1 1PPS Measurements	71
6. Configuration Files	74
6.1 TCS File	74

ZCU670 Multicast Boundary Clock Performance Validation Report

6.2	Ts2phc cfg File	74
6.3	Standalone ptp4l cfg File.....	75
6.4	External Servo ptp4l cfg File	76
6.5	Pcm4l json File	77
6.6	Synced cfg File.....	80
7.	Revision History	81

1. Overview

This report shows the results of Multicast Boundary Clock testing with the ZCU670 platform. Tests results are compared to the ITU-T G.8273.2 Full Time Support Standard. Noise generation tests measure the amount of noise produced at the output of the T-BC when there is an ideal input reference packet timing signal. The noise generation is measured on both the PTP and 1PPS outputs of the DUT. Holdover performance tests check holdover performance by measuring the phase/time output in the event of the loss of the PTP input to the T-BC. The holdover performance is measured on PTP and 1PPS outputs of the DUT.

2. Results Summary

Standard	Configuration	Test Case	Results
G.8273.2	Standalone (ts2phc, ptp4l, synced)	Noise Generation	Pass
		Holdover	Pass
		SyncE to PTP Noise Transfer	Pass
		SyncE to 1PPS Noise Transfer	Pass
		PTP to PTP Noise Transfer	Pass
		PTP to 1PPS Noise Transfer	Pass
		SyncE Transient	Pass
		G.8271.1 Reference Point C PDV	Pass
	External Servo (pcm4l, ptp4l, synced)	Noise Generation	Pass
		Holdover	Pass
		SyncE to PTP Noise Transfer	Pass
		SyncE to 1PPS Noise Transfer	Pass

3. Test Configuration

All tests in this report were completed using a boundary clock configuration as this tests both the **timeReceiver** and **timeTransmitter** functions.

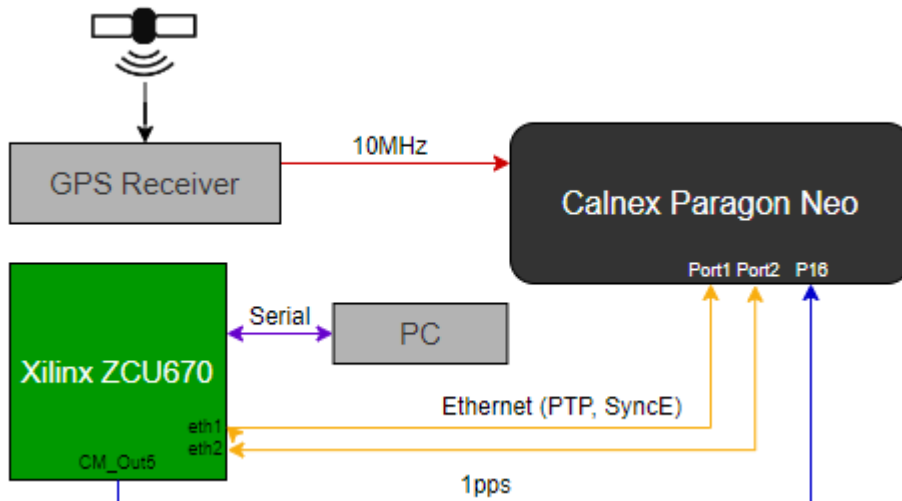

Figure 1. Equipment Configuration

4. Standalone Tests (ts2phc, ptp4l, synced)

4.1 G.8273.2: Noise Generation

The noise generation of a T-BC represents the amount of noise produced at the output of the T-BC when there is an ideal input reference packet timing signal. The noise generation is measured on both the PTP and 1PPS outputs of the DUT.

In this section, the standalone configuration (ts2phc, ptp4l, synced) is tested for conformance to ITU-T G.8273.2 Section 7.1 Class D. Physical layer assistance (SyncE) is used during this test.

4.1.1 PTP Measurements

Test Description	Noise Generation
Report Date	24-09-06_12-21-02
Packet Rate (pkt/s)	16
Beginning of Test	9/5/2024 1:00:56 PM
Test Duration	02:57:49

All Mask Results	Pass
Mask TIMEERROR	0.05 μ s
Mask TIMEERROR Result	Pass
Mask FILTEREDTIMEERROR	0.005 μ s
Mask FILTEREDTIMEERROR Result	Pass
Mask CTE	0.01 μ s
Mask CTE Result	Pass
Mask DTE	0.01 μ s
Mask DTE Result	Pass
Mask DTEHF	0.07 μ s
Mask DTEHF Result	Pass
Mask DTEMTIE	G.8273.2 T-BC Class C Dynamic TE LF Const. Temp.
Mask DTEMTIE Result	Pass
Mask DTETDEV	G.8273.2 T-BC Class C Dynamic TE LF Const. Temp.
Mask DTETDEV Result	Pass

4.1.1.1 TIMEERROR Analysis

Date: 2024-09-05
File: Ptp1588100.CDF
Include Correction Field: True
Packet Selection: False

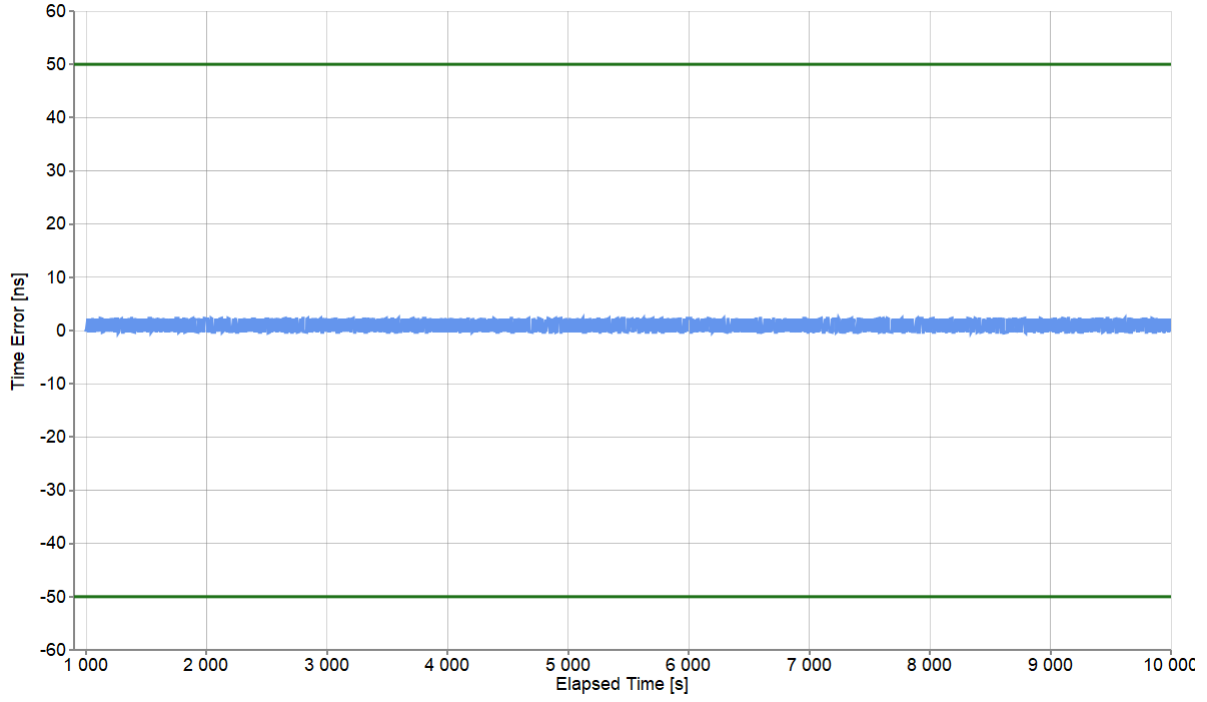

Pk-Pk [ns]	2.75
Mean [ns]	0.948
Min [ns]	-0.452
Max [ns]	2.298

4.1.1.2 FILTEREDTIMEERROR Analysis

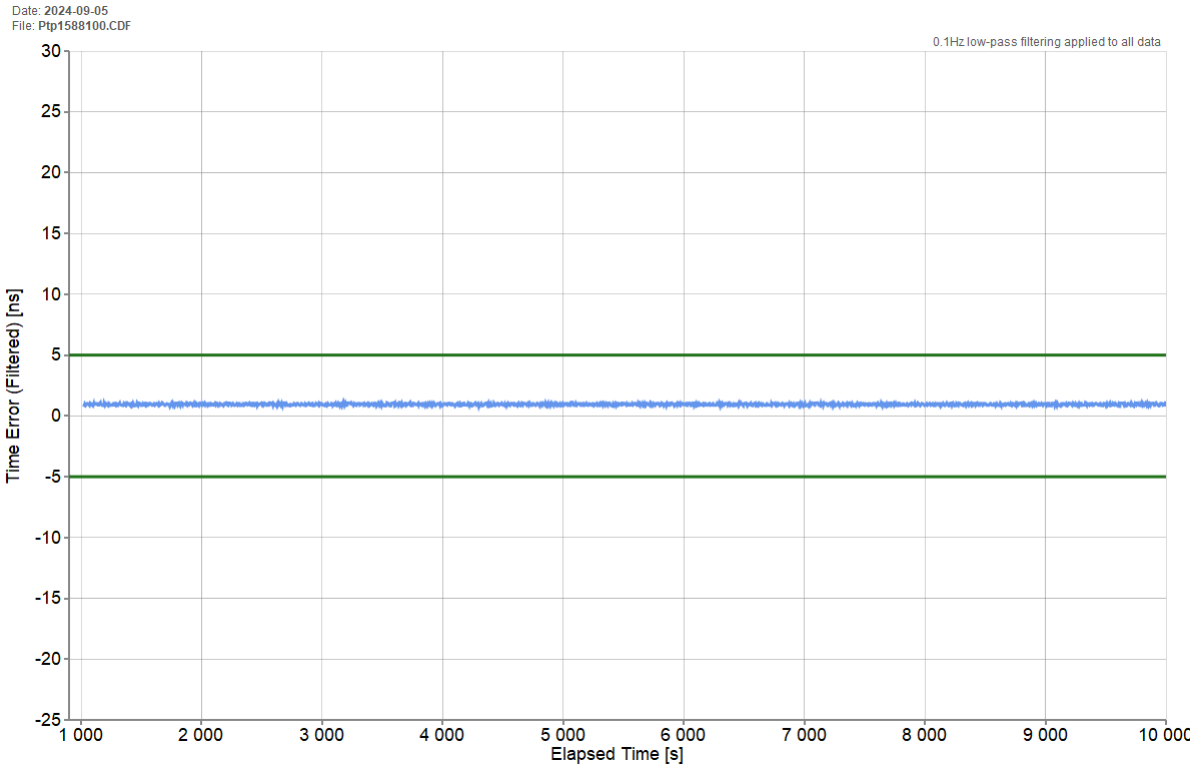

Mean [ns]	0.948
Min [ns]	0.758
Max [ns]	1.169
Max-Min [ns]	0.41

4.1.1.3 CTE Analysis

Date: 2024-09-05
 File: Ptp1588100.CDF
 Averaging Period: 1000s

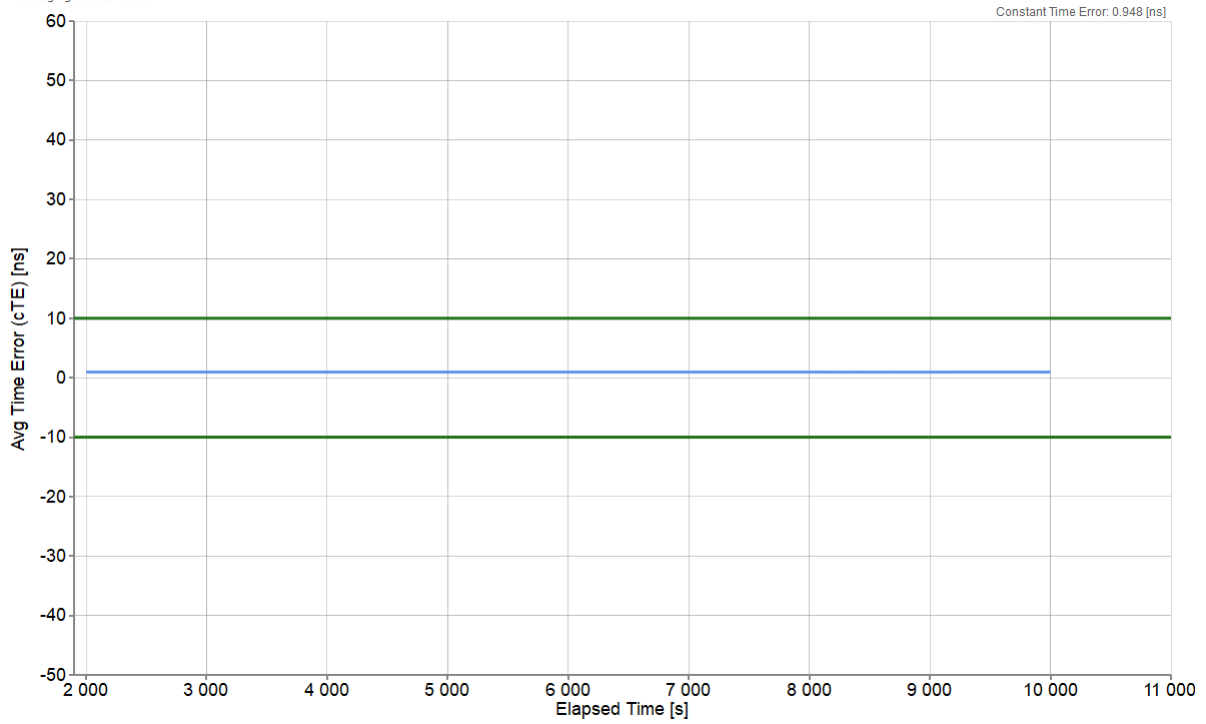

Averaging Time (s)	1000
Constant Time Error [ns]	0.948
Min [ns]	0.943
Max [ns]	0.953
Max-Min [ns]	0.01

4.1.1.4 DTE Analysis

Date: 2024-09-05
File: Ptp1588100.CDF
Remove Settling: True
Normalization: True

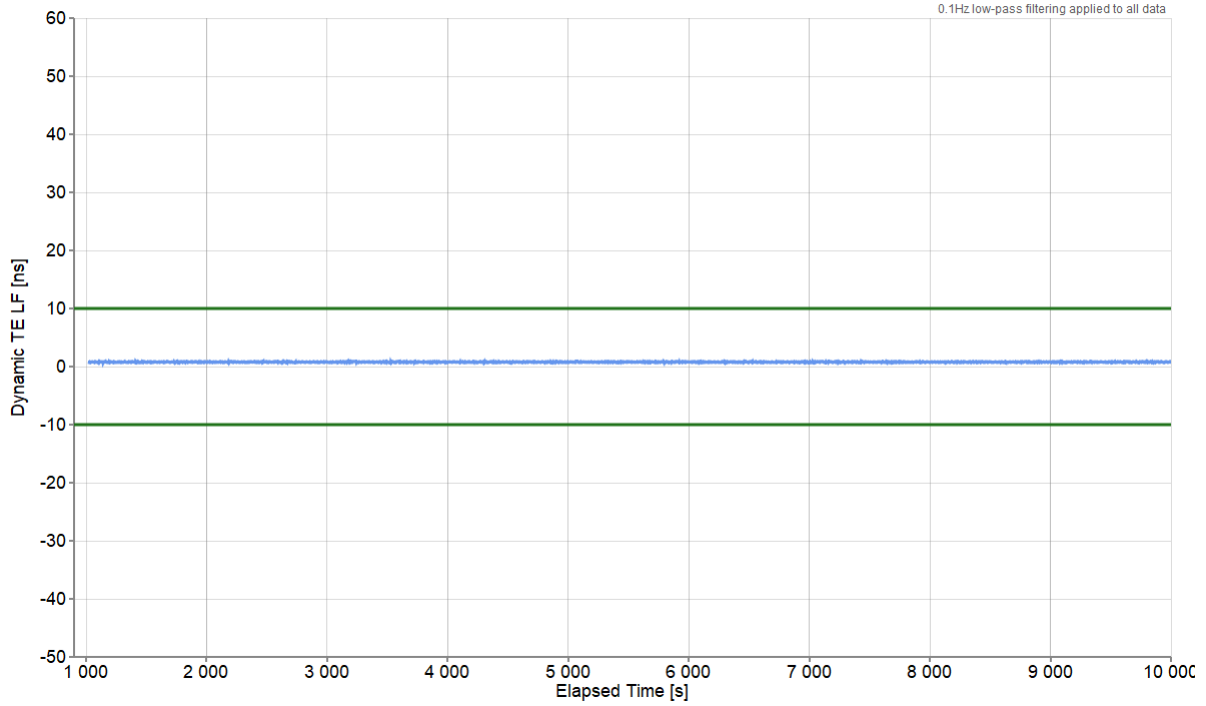

Mean [ns]	0.775
Min [ns]	0.585
Max [ns]	0.996
Max-Min [ns]	0.41

4.1.1.5 DTEHF Analysis

Date: 2024-09-05
File: Ptp1588100.CDF
Normalization: True

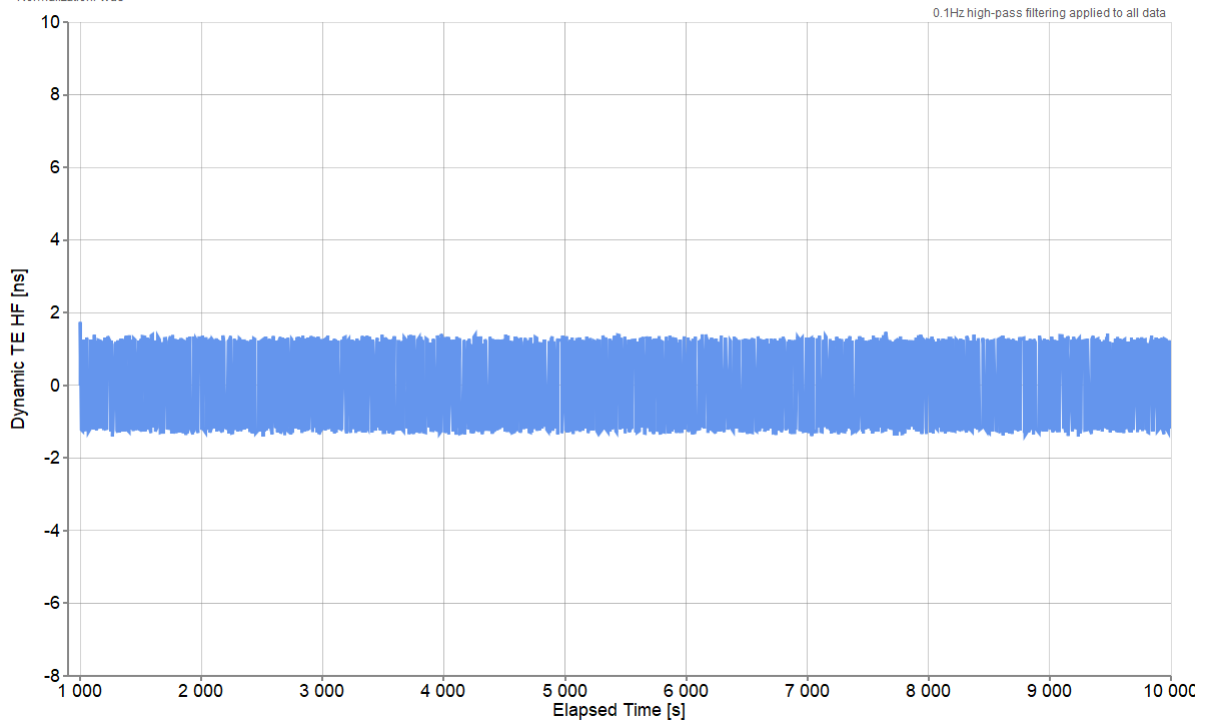

Pk-Pk [ns]	3.153
Mean [ns]	0
Min [ns]	-1.412
Max [ns]	1.741

4.1.1.6 DTEMTIE Analysis

Date: 2024-09-05
File: Ptp1588100.CDF

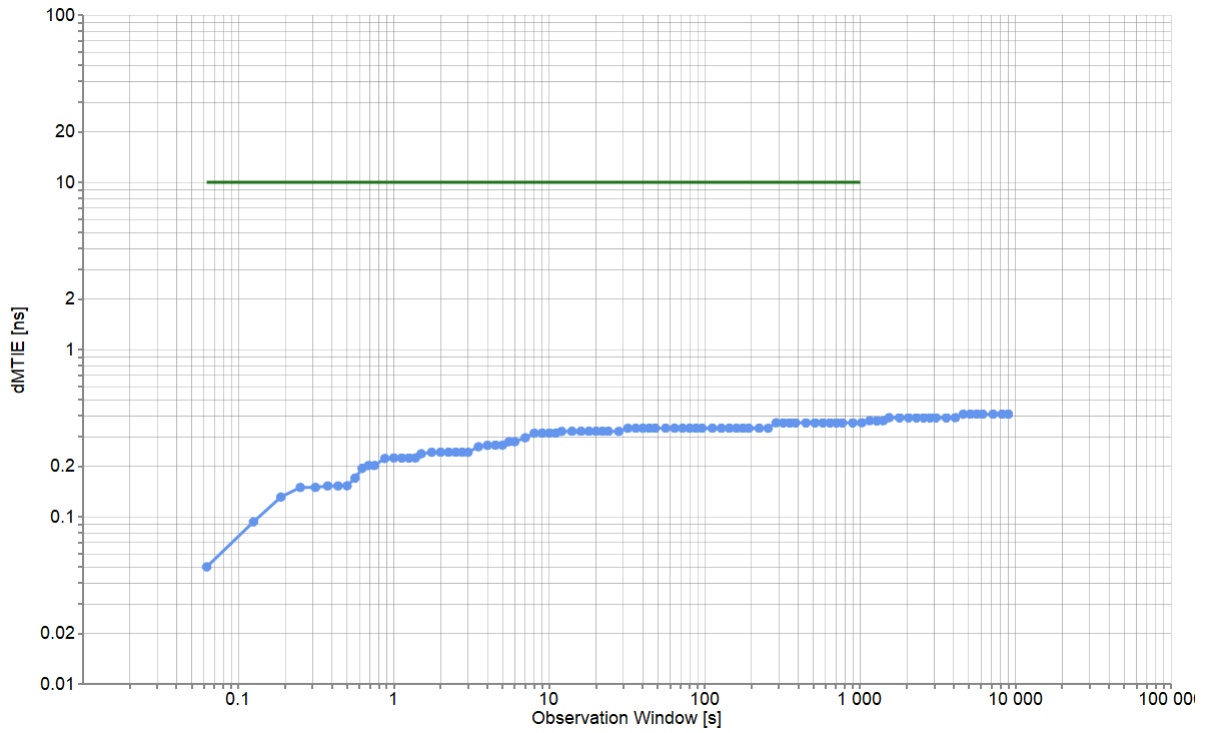

Min [ns]	0.05
Max [ns]	0.41
Max-Min [ns]	0.36

4.1.1.7 DTETDEV Analysis

Date: 2024-09-05
File: Ptp1588100.CDF

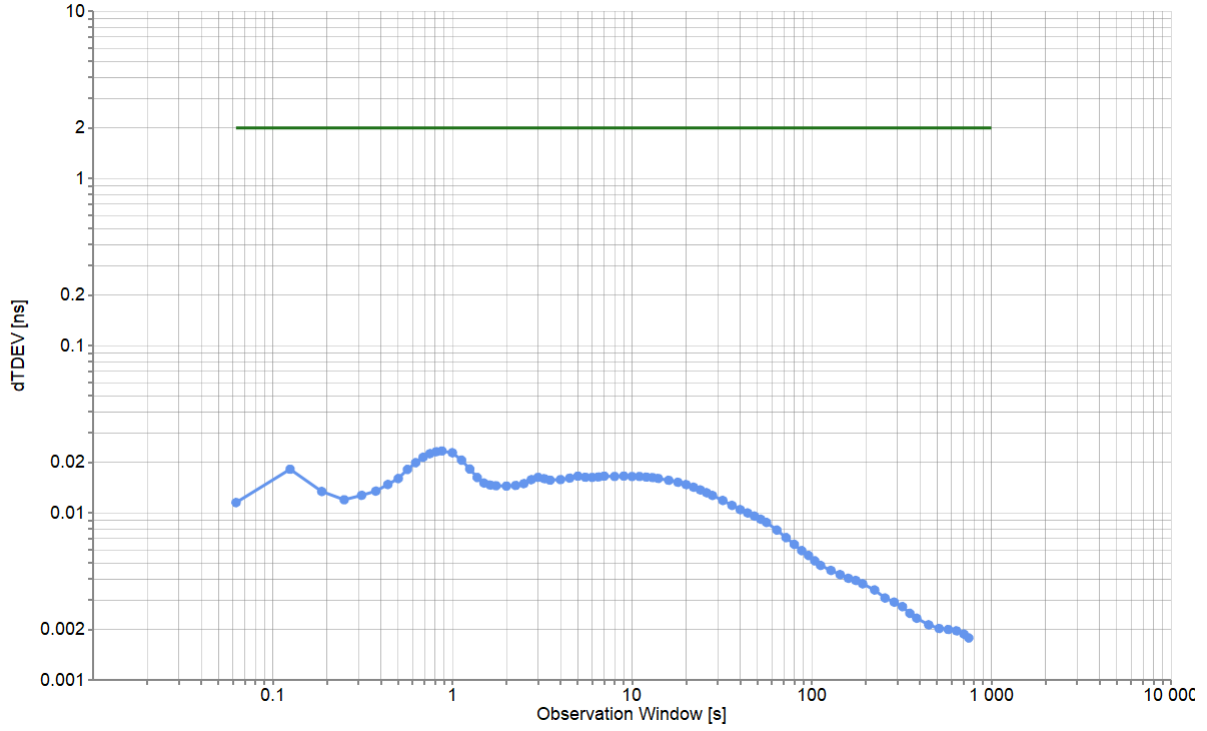

Min [ns]	0.002
Max [ns]	0.023
Max-Min [ns]	0.022

4.1.2 1PPS Measurements

Test Description	Noise Generation
Report Date	24-09-06_12-21-02
Packet Rate (pkt/s)	16
Beginning of Test	9/5/2024 1:00:58 PM
Test Duration	02:30:00

All Mask Results	Pass
Mask ONEPPS	0.03μs
Mask ONEPPS Result	Pass
Mask FILTEREDTIMEERROR	0.005μs
Mask FILTEREDTIMEERROR Result	Pass
Mask CTE	0.01μs
Mask CTE Result	Pass
Mask DTE	0.01μs
Mask DTE Result	Pass
Mask DTEHF	0.07μs
Mask DTEHF Result	Pass
Mask DTEMTIE	G.8273.2 T-BC Provisional Class D Dynamic TE LF Const. Temp.
Mask DTEMTIE Result	Pass
Mask DTETDEV	G.8273.2 T-BC Provisional Class D Dynamic TE LF Const. Temp.
Mask DTETDEV Result	Pass

4.1.2.1 ONEPPS Analysis

Offset Removal Applied	Off
Zero Offset	0.447 ns

Date: 2024-09-05
 File: Time Error_06-09-2024_12-15-21.csv
 Offset Removal Applied: False
 Zero Offset: 0.447ns

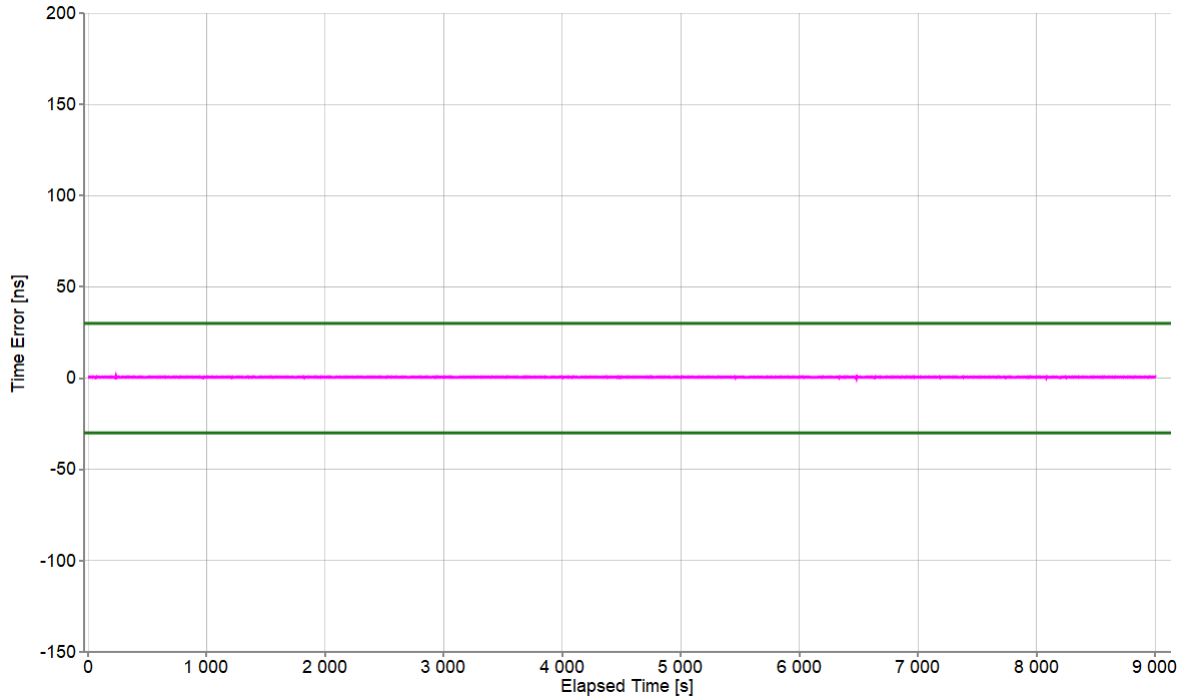

Mean [ns]	0.47
Min [ns]	0.197
Max [ns]	0.697
Max-Min [ns]	0.5

4.1.2.2 FILTEREDTIMEERROR Analysis

Date: 2024-09-05
File: Time Error_06-09-2024_12-15-21.csv

0.1Hz low-pass filtering applied to all data

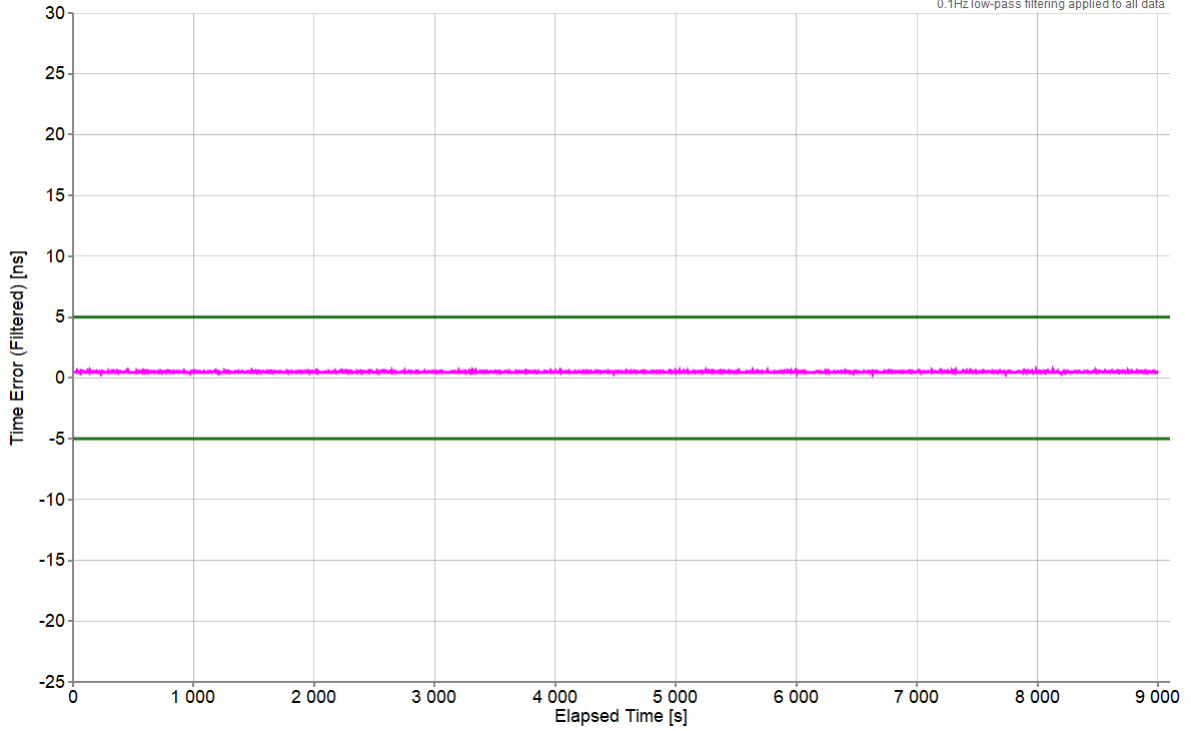

Mean [ns]	0.47
Min [ns]	0.354
Max [ns]	0.673
Max-Min [ns]	0.319

4.1.2.3 CTE Analysis

Date: 2024-09-05
 File: Time_Error_06-09-2024_12-15-21.csv
 Averaging Period: 1000s

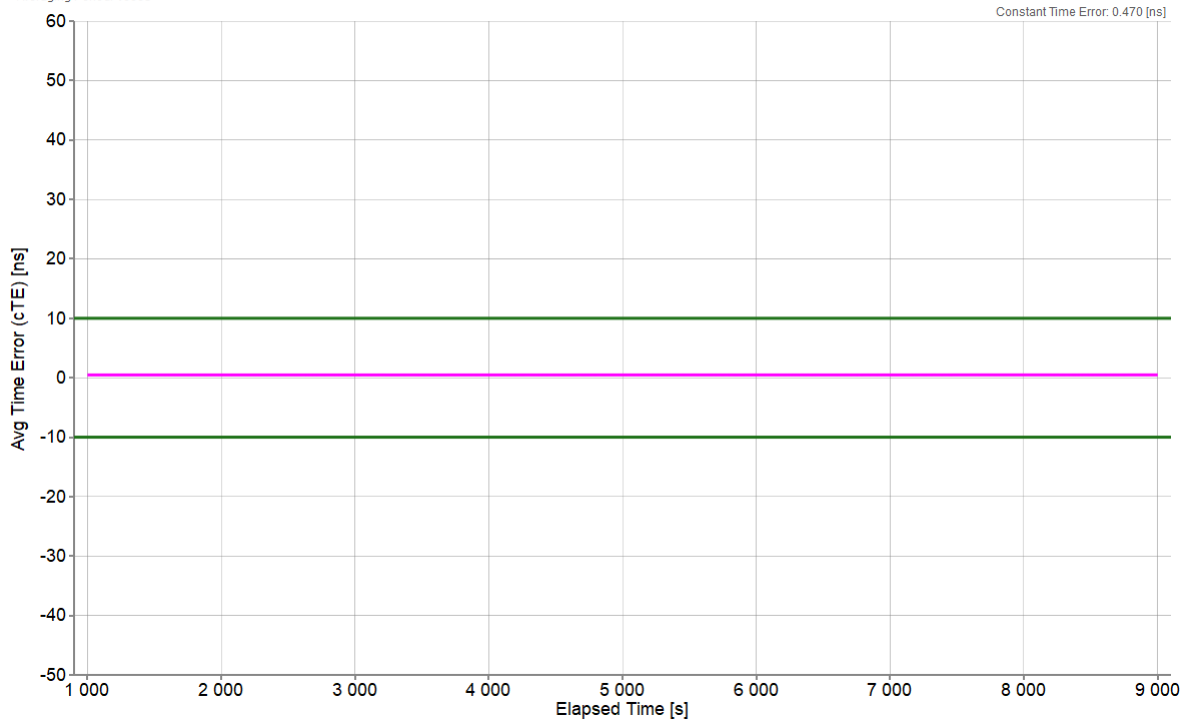

Averaging Time (s)	1000
Constant Time Error [ns]	0.47
Min [ns]	0.465
Max [ns]	0.478
Max-Min [ns]	0.013

4.1.2.4 DTE Analysis

Date: 2024-09-05
File: Time Error_06-09-2024_12-15-21.csv
Remove Settling: True
Normalization: True

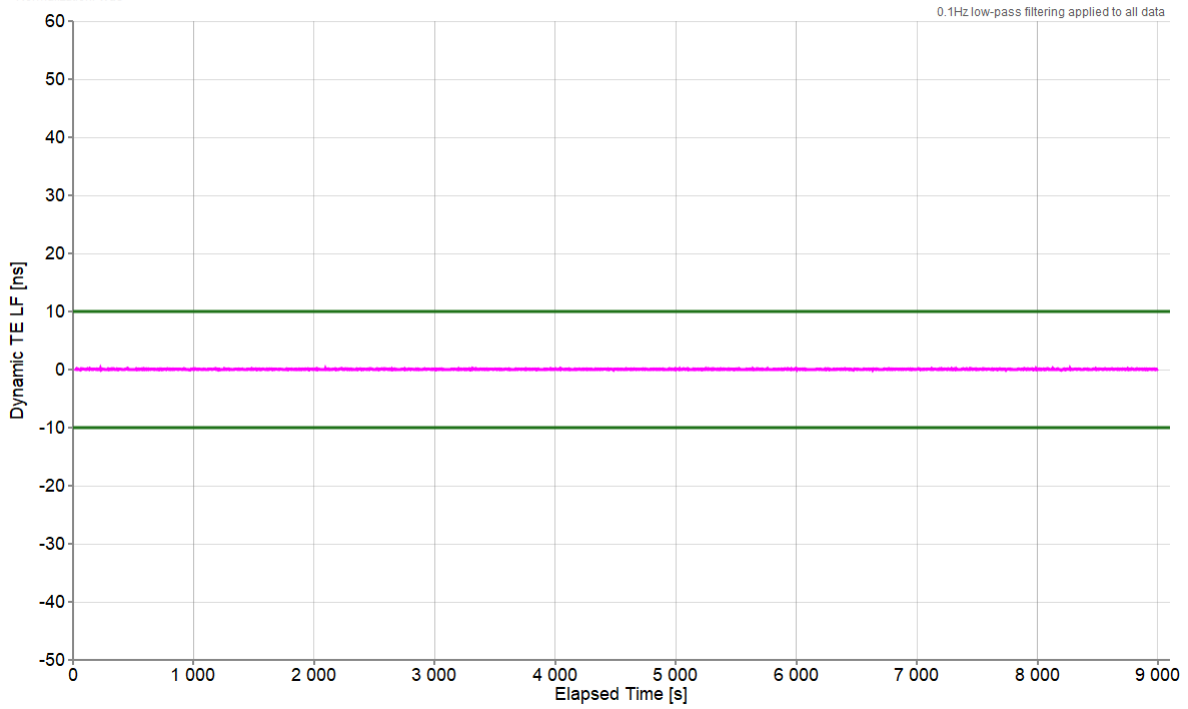

Mean [ns]	0.023
Min [ns]	-0.093
Max [ns]	0.226
Max-Min [ns]	0.319

4.1.2.5 DTEHF Analysis

Date: 2024-09-05
File: Time Error_06-09-2024_12-15-21.csv
Normalization: True

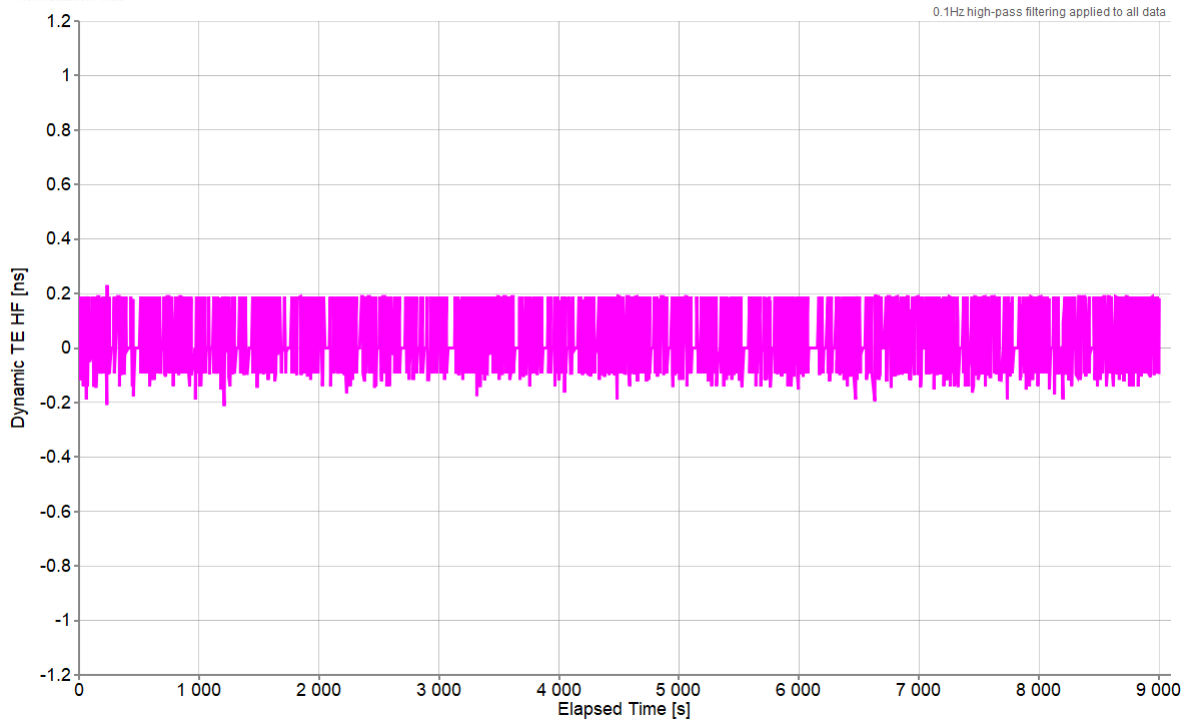

Mean [ns]	0
Min [ns]	-0.213
Max [ns]	0.231
Max-Min [ns]	0.443

4.1.2.6 DTEMTIE Analysis

Date: 2024-09-05
 File: Time Error_06-09-2024_12-15-21.csv

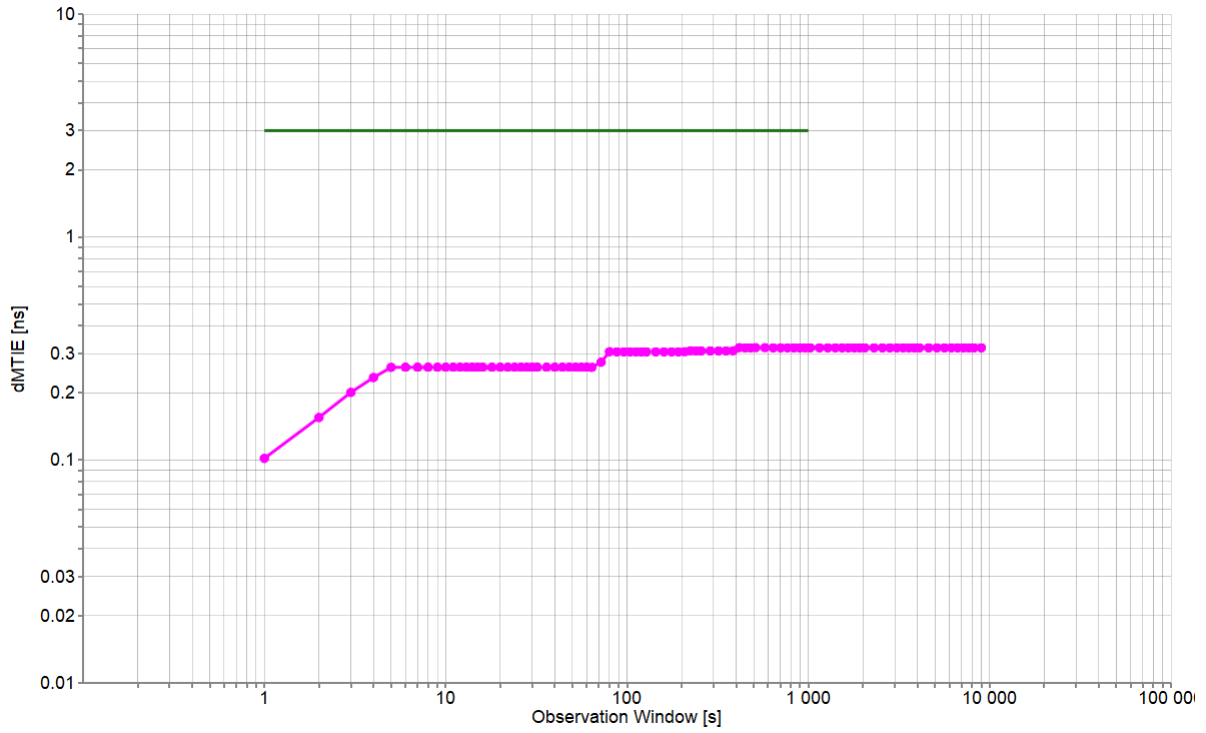

Min [ns]	0.102
Max [ns]	0.319
Max-Min [ns]	0.217

4.1.2.7 DTETDEV Analysis

Date: 2024-09-05
 File: Time Error_06-09-2024_12-15-21.csv

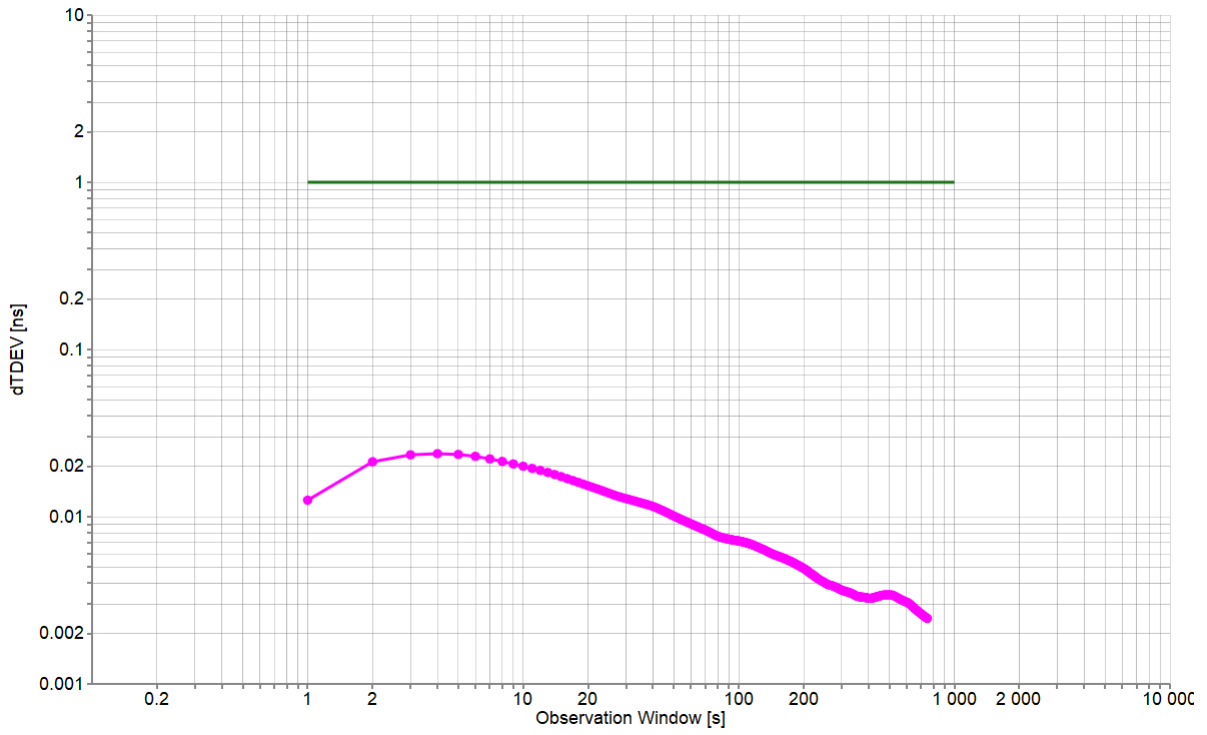

Min [ns]	0.002
Max [ns]	0.024
Max-Min [ns]	0.021

4.2 G.8273.2: Holdover

Holdover performance is checked by measuring the phase/time output in the event of the loss of the PTP input to the T-BC. The holdover performance is measured on PTP and 1PPS outputs of the DUT.

In this section, the standalone configuration (ts2phc, ptp4l, synced) is tested for conformance to ITU-T G.8273.2 Section 7.4.2.2 Class B. Physical layer assistance (SyncE) is used during this test.

4.2.1 PTP Measurements

Test Description	Holdover
Report Date	24-09-06_12-21-02
Packet Rate (pkt/s)	16
Beginning of Test	9/6/2024 1:53:32 AM
Test Duration	09:55:12

All Mask Results	Pass
Mask TIMEERROR	N/A
Mask TIMEERROR Result	NoMask
Mask DTE	N/A
Mask DTE Result	NoMask
Mask DTEMTIE	G.8273.2 T-BC Class B Time Holdover Const. Temp.
Mask DTEMTIE Result	Pass

4.2.1.1 TIMEERROR Analysis

Date: 2024-09-06
File: Ptp1588100.CDF
Include Correction Field: True
Packet Selection: False

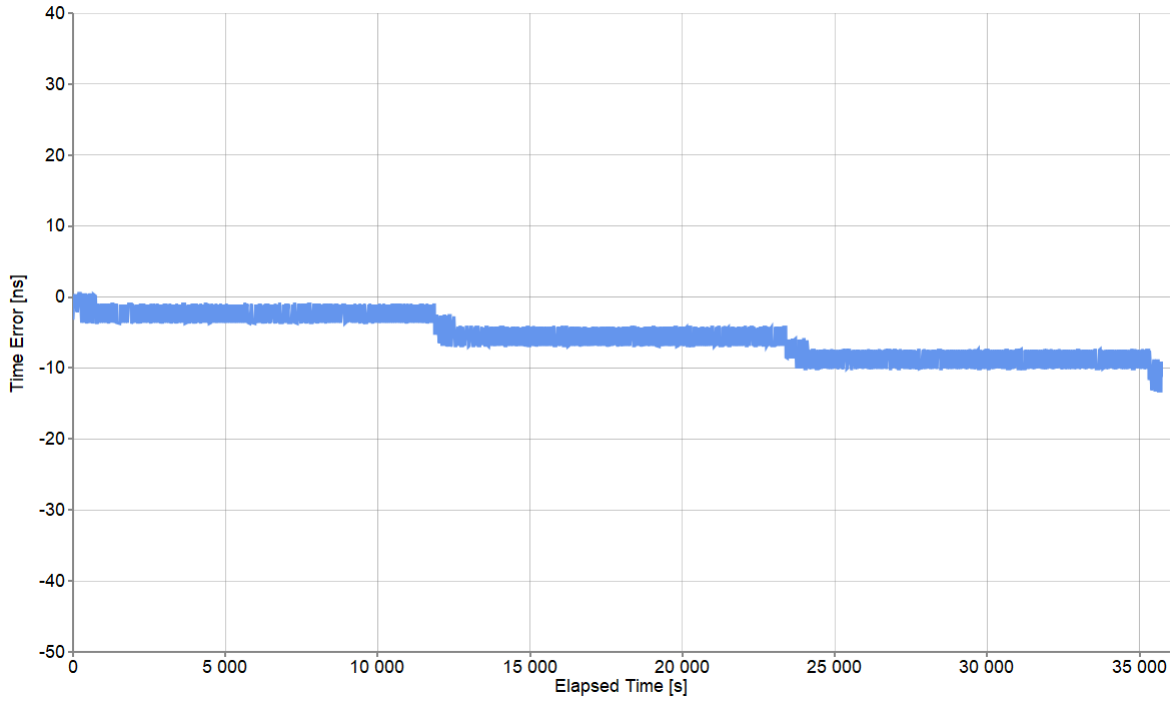

Pk-Pk [ns]	13.75
Mean [ns]	-5.548
Min [ns]	-13.237
Max [ns]	0.513

4.2.1.2 DTE Analysis

Date: 2024-09-06
File: Ptp1588100.CDF
Remove Settling: True
Normalization: True

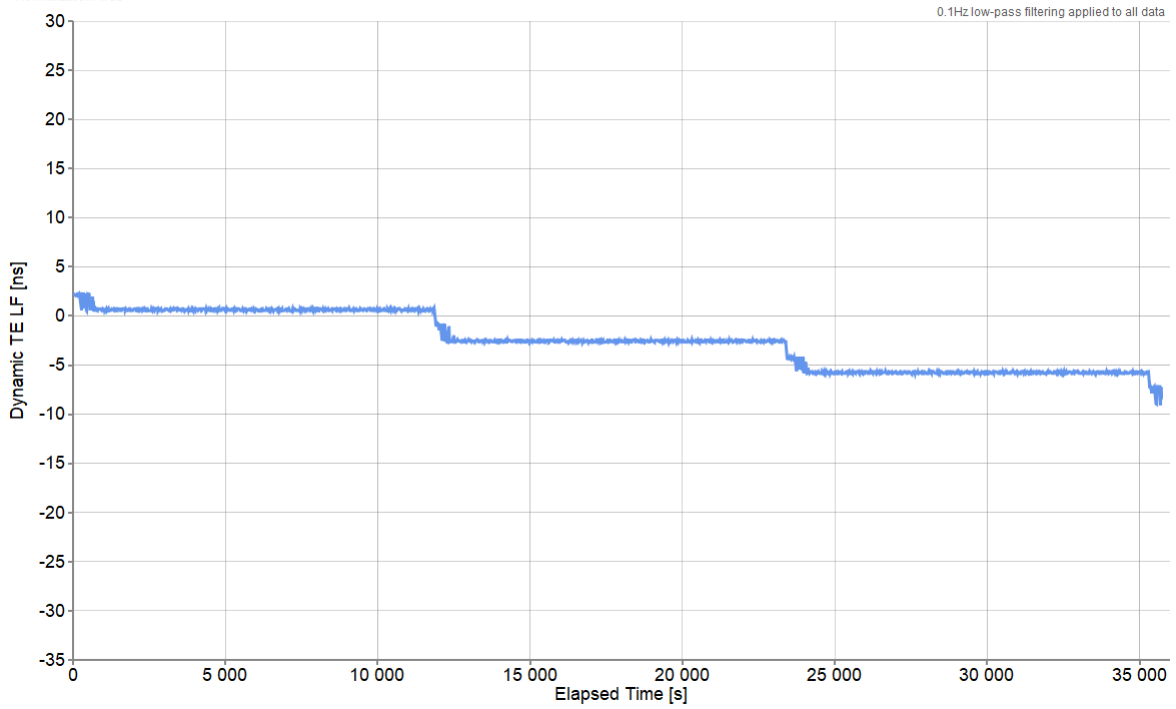

Mean [ns]	-2.562
Min [ns]	-9.065
Max [ns]	2.261
Max-Min [ns]	11.326

4.2.1.3 DTEMTIE Analysis

Date: 2024-09-06
File: Ptp1588100.CDF

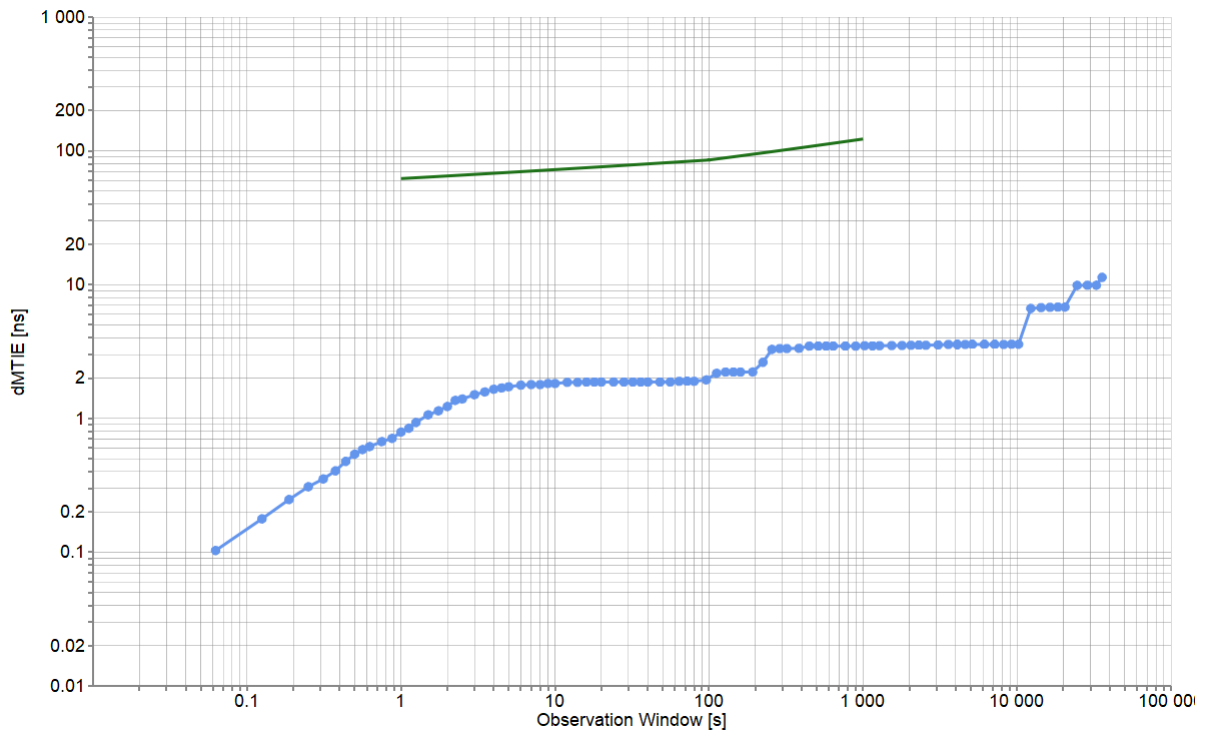

Min [ns]	0.103
Max [ns]	11.326
Max-Min [ns]	11.223

4.2.2 1PPS Measurements

Test Description	Holdover
Report Date	24-09-06_12-21-02
Packet Rate (pkt/s)	16
Beginning of Test	9/6/2024 1:53:32 AM
Test Duration	09:55:10

All Mask Results	Pass
Mask ONEPPS	N/A
Mask ONEPPS Result	NoMask
Mask MTIE	G.8273.2 T-BC Class B Time Holdover Const. Temp.
Mask MTIE Result	Pass

4.2.2.1 ONEPPS Analysis

Offset Removal Applied	Off
Zero Offset	0.197 ns

Date: 2024-09-06
 File: OnePpsAccuracyTod100.CDF
 Offset Removal Applied: False
 Zero Offset: 0.197ns

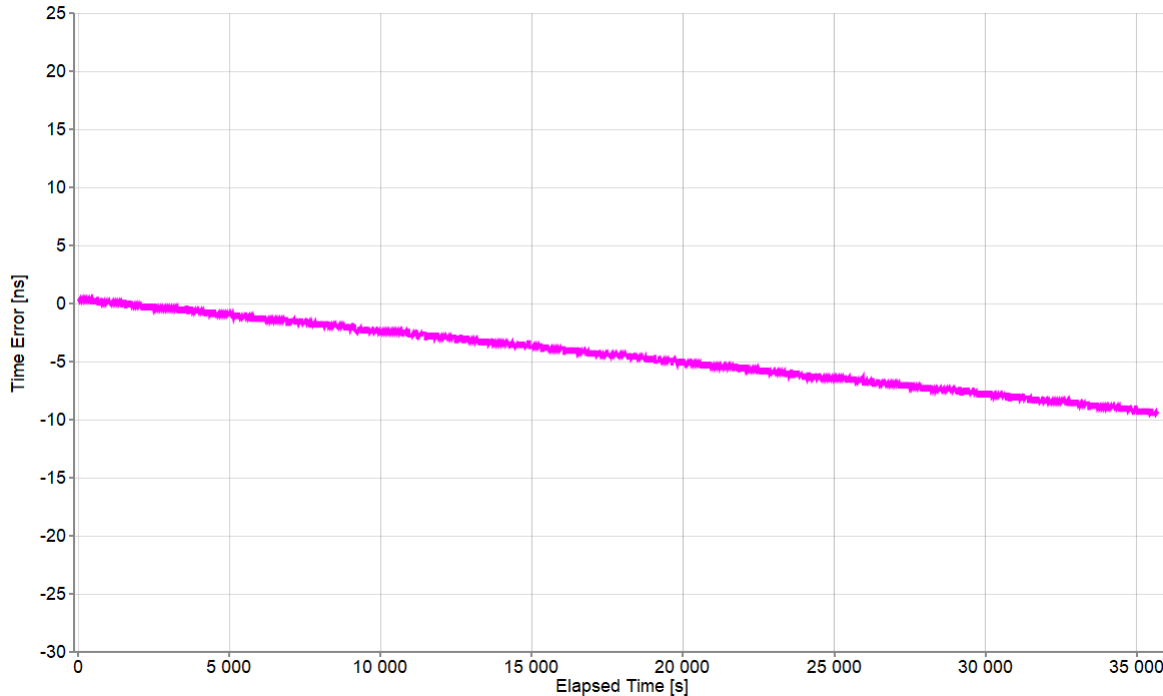

Mean [ns]	-4.563
Min [ns]	-9.553
Max [ns]	0.447
Max-Min [ns]	10

4.2.2.2 MTIE Analysis

Date: 2024-09-06
 File: OnePpsAccuracyTod100.CDF

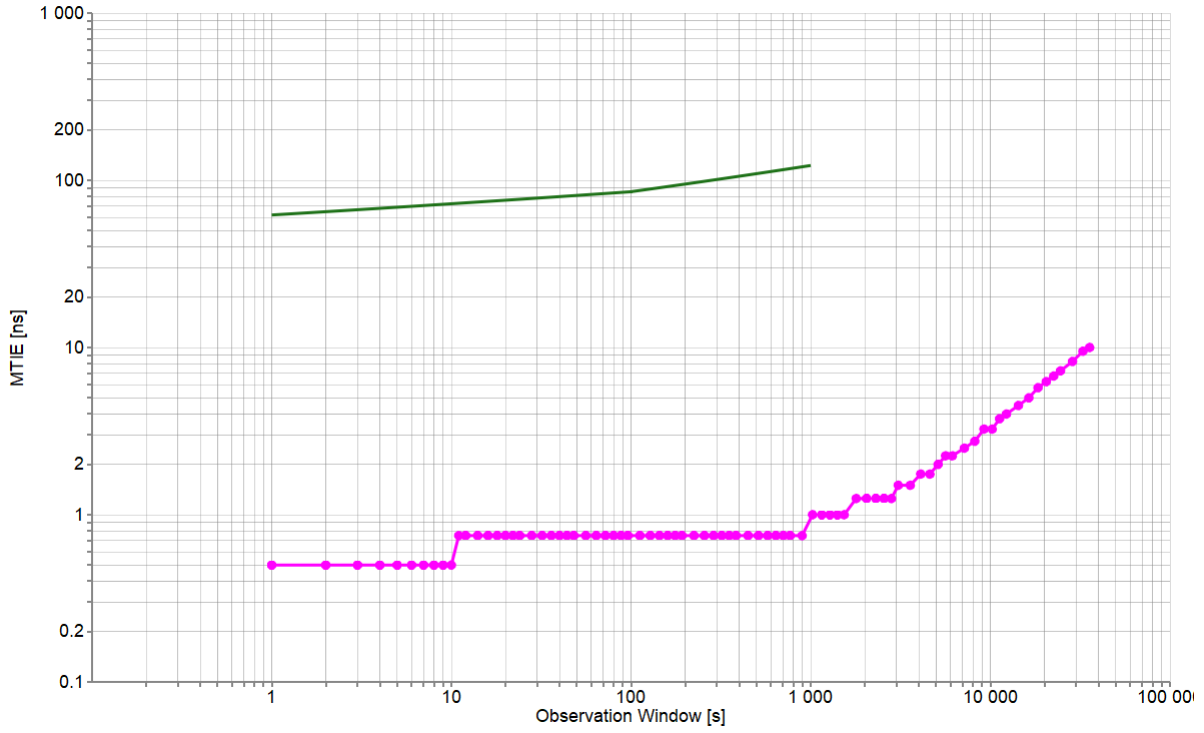

Min [ns]	0.5
Max [ns]	10
Max-Min [ns]	9.5

4.3 G.8273.2: SyncE to PTP Noise Transfer

According to ITU-T G.8273.2 Section 7.3.3, the output PTP signal and 1 PPS signal must correspond to the input physical layer frequency input signal on which a band-pass filter whose lower corner frequency is between 0.05Hz and 0.1Hz and whose upper corner frequency is between 1Hz and 10Hz has been applied. This test checks whether T-BC under evaluation meets this bandpass filter requirement by adding sinusoidal noise on the SyncE (physical layer) input and measuring the output PTP noise amplitude.

In this section, the standalone configuration (ts2phc, ptp4l, synced) with physical later assistance (SyncE) is tested for conformance to the Class C standard.

4.3.1 PTP Measurements

Test Description	SyncE To PTP Noise Transfer
Report Date	24-09-06_12-21-02
Packet Rate (pkt/s)	16
Beginning of Test	9/5/2024 7:31:49 PM
Test Duration	01:16:43

All Mask Results	Pass
Mask TIMEERROR	0.32μs
Mask TIMEERROR Result	Pass
Mask SyncENoiseTransfer	G.8273.2 Class C T-BCs Noise Transfer
Mask SyncENoiseTransfer Result	Pass

4.3.1.1 TIMEERROR Analysis

Date: 2024-09-05
 File: Ptp1588100.CDF
 Include Correction Field: True
 Packet Selection: False

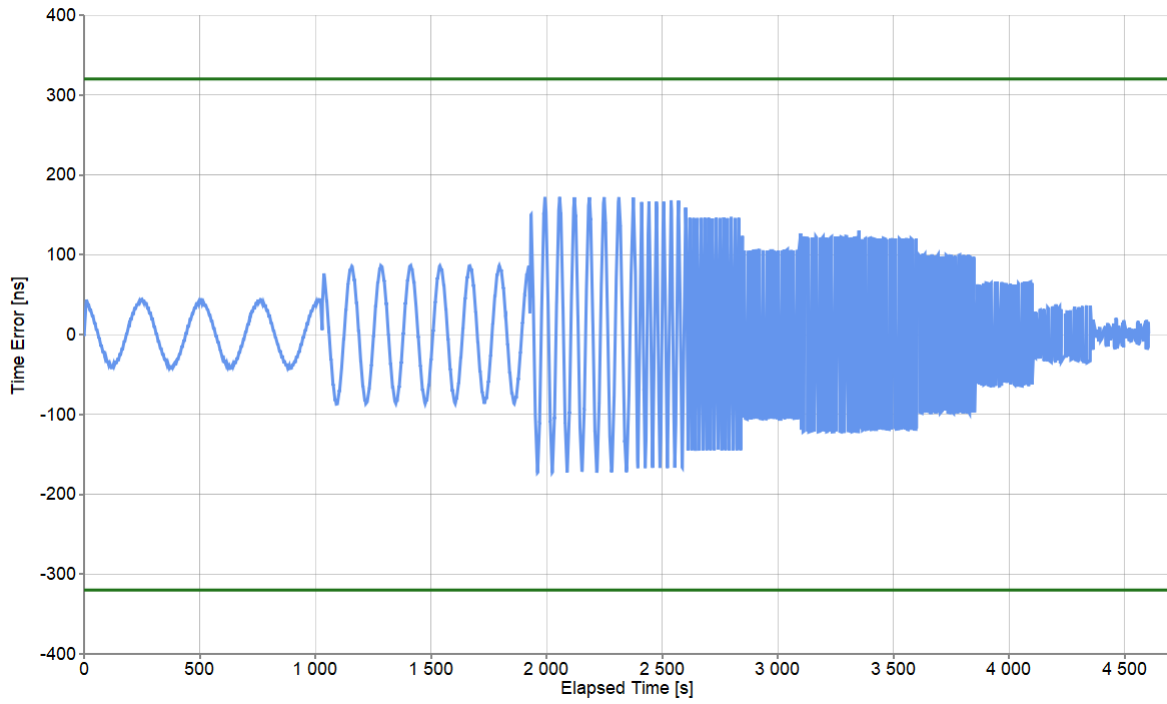

Pk-Pk [ns]	345.25
Mean [ns]	0.356
Min [ns]	-173.07
Max [ns]	172.18

4.3.1.2 SyncNoiseTransfer Analysis

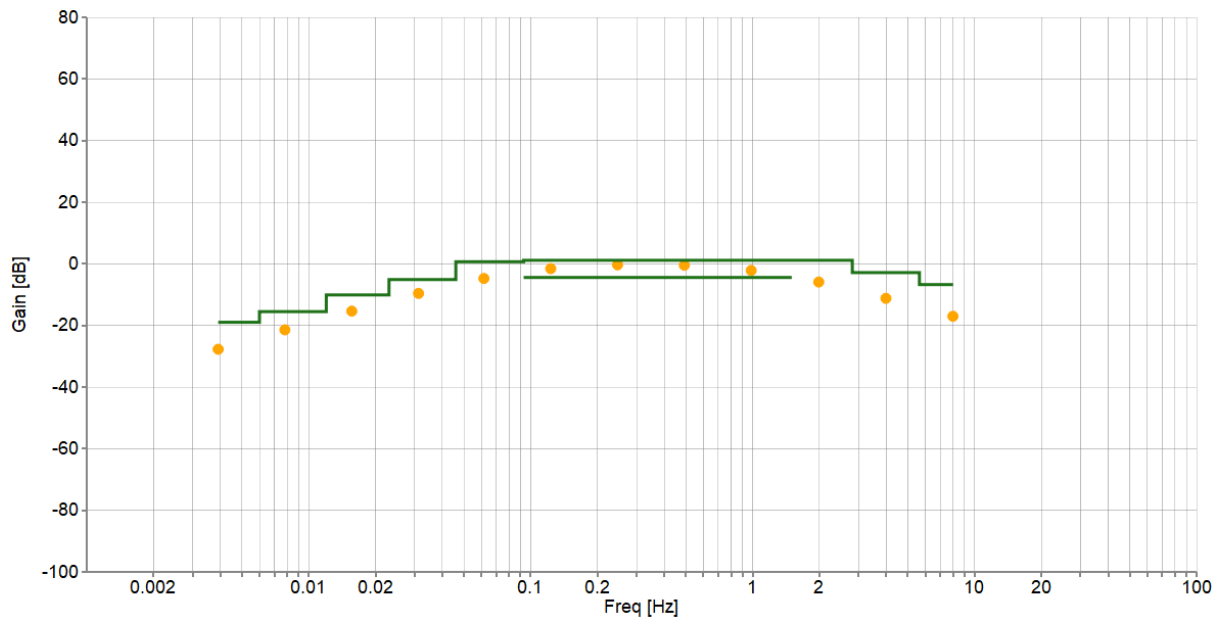

Point #	Freq (Hz)	Ampl (ns)	Duration (s)	Pk-Pk Output (ns)	Gain (dB)	Upper Pk-Pk Limit (ns)	Lower Pk-Pk Limit (ns)
1	0.00391	2000	1023.02	82.02	-27.74	225	-
2	0.00781	2000	896.29	169.53	-21.44	340	-
3	0.01563	2000	447.86	341.05	-15.36	630	-
4	0.03125	1000	224.00	331.05	-9.60	565	-
5	0.06156	500	243.66	288.80	-4.77	545	-
6	0.12313	250	251.77	208.66	-1.57	285	150
7	0.24625	250	251.78	240.75	-0.33	285	150
8	0.4925	250	249.75	236.57	-0.48	285	150
9	0.985	250	249.75	194.96	-2.16	285	150
10	1.985	250	249.87	126.63	-5.91	285	-
11	3.985	250	249.94	68.75	-11.21	285	-
12	7.985	250	249.97	35.13	-17.05	285	-

4.4 G.8273.2: SyncE to 1PPS Noise Transfer

According to ITU-T G.8273.2 Section 7.3.3, the output 1PPS signal and 1 PPS signal must correspond to the input physical layer frequency input signal on which a band-pass filter whose lower corner frequency is between 0.05Hz and 0.1Hz and whose upper corner frequency is between 1Hz and 10Hz has been applied. This test checks whether T-BC under evaluation meets this bandpass filter requirement by adding sinusoidal noise on the SyncE (physical layer) input and measuring the output 1PPS noise amplitude.

In this section, the standalone configuration (ts2phc, ptp4l, synced) with physical later assistance (SyncE) is tested for conformance to the class C standard.

4.4.1 1PPS Measurements

Test Description	SyncE to 1PPS Noise Transfer
Report Date	24-09-06_12-21-02
Packet Rate (pkt/s)	16
Beginning of Test	9/5/2024 7:31:49 PM
Test Duration	01:16:42

All Mask Results	Pass
Mask ONEPPS	0.32μs
Mask ONEPPS Result	Pass
Mask SyncENoiseTransfer	G.8273.2 Class C T-BCs Noise Transfer
Mask SyncENoiseTransfer Result	Pass

4.4.1.1 ONEPPS Analysis

Offset Removal Applied	Off
Zero Offset	0.697ns

Date: 2024-09-05
 File: OnePpsAccuracyTod100.CDF
 Offset Removal Applied: False
 Zero Offset: 0.697ns

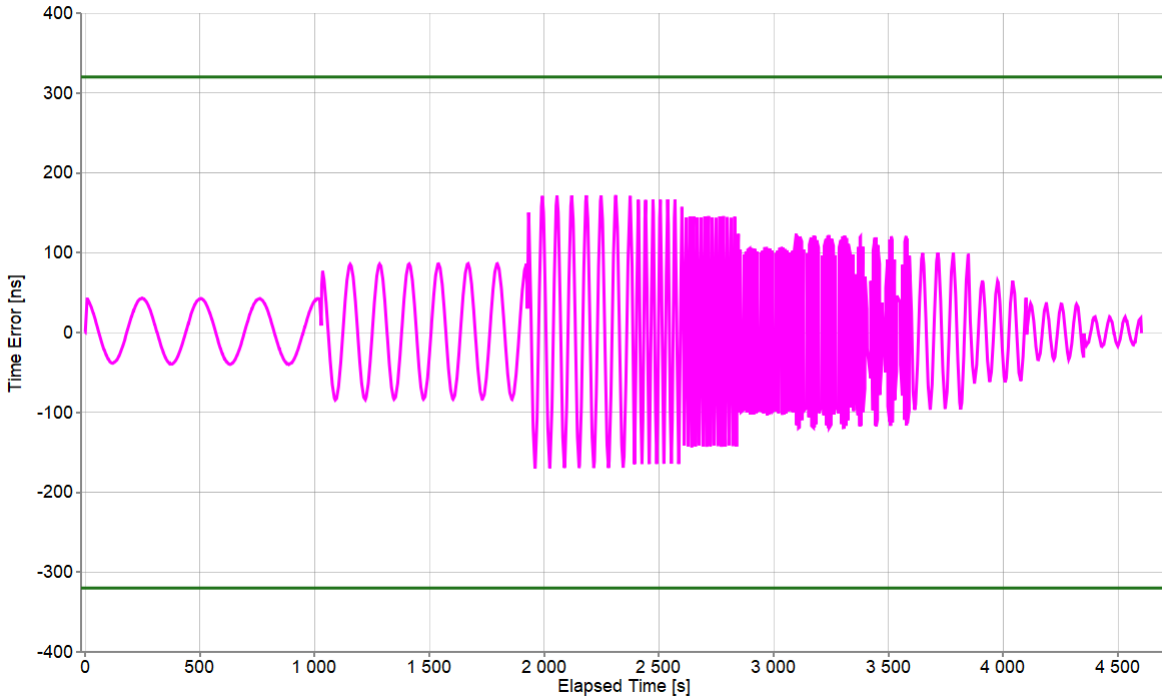

Mean [ns]	0.968
Min [ns]	-170.053
Max [ns]	171.947
Max-Min [ns]	342

4.4.1.2 SyncNoiseTransfer Analysis

Date: 2024-09-05
File: OnePpsAccuracyTod100.CDF

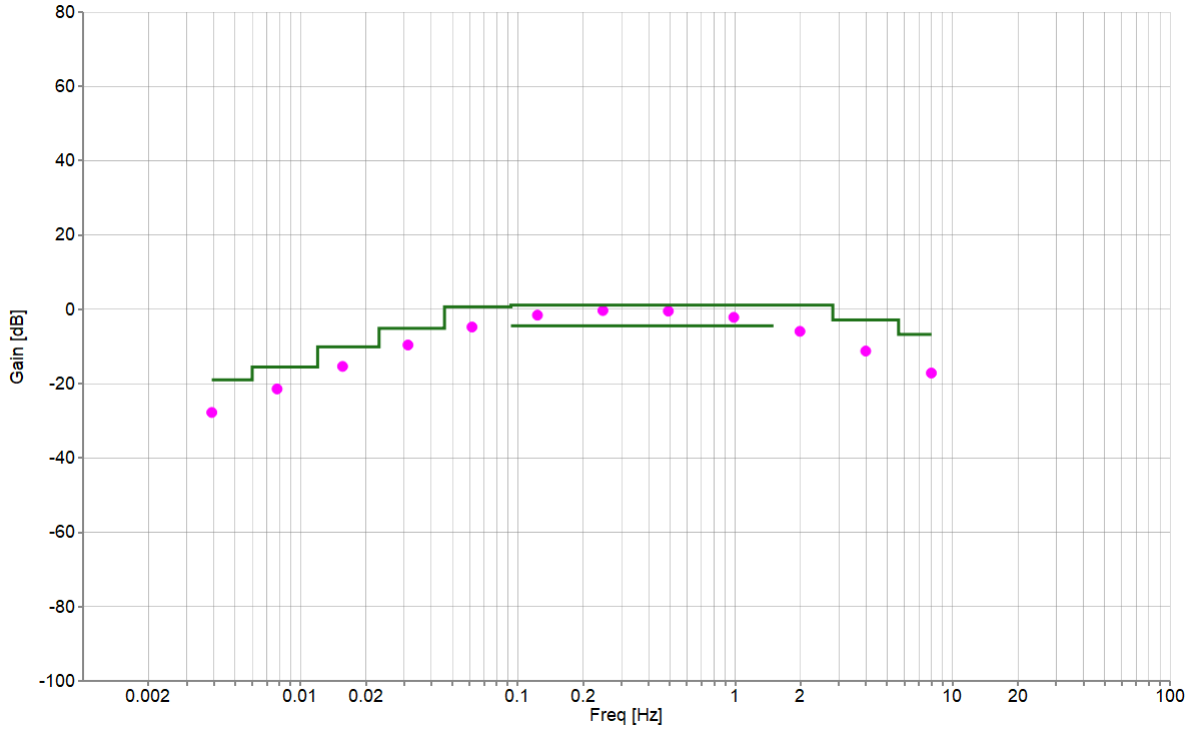

Point #	Freq (Hz)	Ampl (ns)	Duration (s)	Pk-Pk Output (ns)	Gain (dB)	Upper Pk-Pk Limit (ns)	Lower Pk-Pk Limit (ns)
1	0.00391	2000	1023.02	81.87	-27.76	225	-
2	0.00781	2000	896.29	169.71	-21.43	340	-
3	0.01563	2000	447.86	341.09	-15.36	630	-
4	0.03125	1000	224.00	331.09	-9.60	565	-
5	0.06156	500	243.66	288.80	-4.77	545	-
6	0.12313	250	251.77	208.74	-1.57	285	150
7	0.24625	250	251.78	240.79	-0.33	285	150
8	0.4925	250	249.75	236.52	-0.48	285	150
9	0.985	250	249.75	194.97	-2.16	285	150
10	1.985	250	249.87	126.40	-5.92	285	-
11	3.985	250	249.94	68.63	-11.23	285	-
12	7.985	250	249.97	34.72	-17.15	285	-

4.5 G.8273.2: PTP to PTP Noise Transfer

According to ITU-T G.8273.3 Section 7.3, the output PTP signal and 1 PPS signal must correspond to the input physical layer frequency input signal on which a band-pass filter whose lower corner frequency is between 0.05Hz and 0.1Hz and whose upper corner frequency is between 1Hz and 10Hz has been applied. This test checks whether T-BC under evaluation meets this bandpass filter requirement by adding sinusoidal noise on the SyncE (physical layer) input and measuring the output PTP noise amplitude.

In this section, the standalone configuration (ts2phc, ptp4l, synced) with physical later assistance (SyncE) is tested for conformance to the Class C standard.

4.5.1 PTP Measurements

Test Description	PTP to PTP Noise Transfer
Report Date	24-09-06_12-21-02
Packet Rate (pkt/s)	16
Beginning of Test	9/5/2024 8:56:39 PM
Test Duration	04:28:13

All Mask Results	Pass
Mask TIMEERROR	0.32μs
Mask TIMEERROR Result	Pass
Mask PTPNoiseTransfer	G.8273.2 Class C T-BCs Noise Transfer
Mask PTPNoiseTransfer Result	Pass

4.5.1.1 TIMEERROR Analysis

Date: 2024-09-05
 File: Ptp1588100.CDF
 Include Correction Field: True
 Packet Selection: False

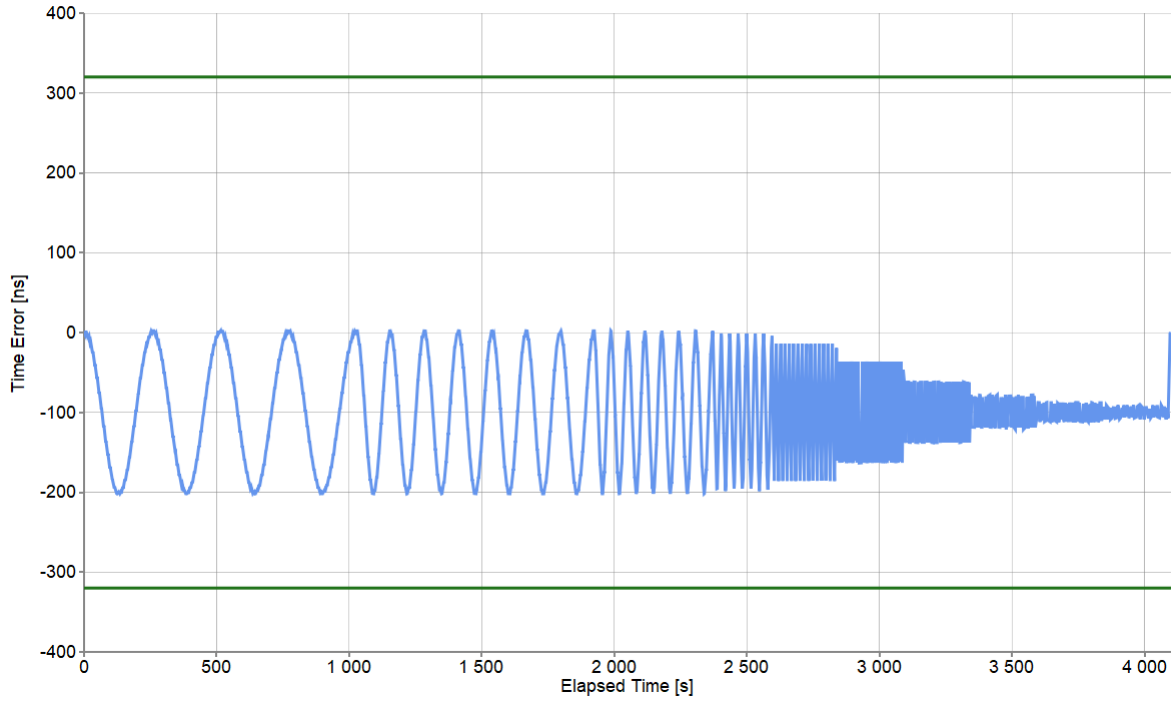

Pk-Pk [ns]	204.25
Mean [ns]	-99.478
Min [ns]	-202.075
Max [ns]	2.175

4.5.1.2 PTPNoiseTransfer Analysis

Date: 2024-09-05
File: Ptp1588100.CDF

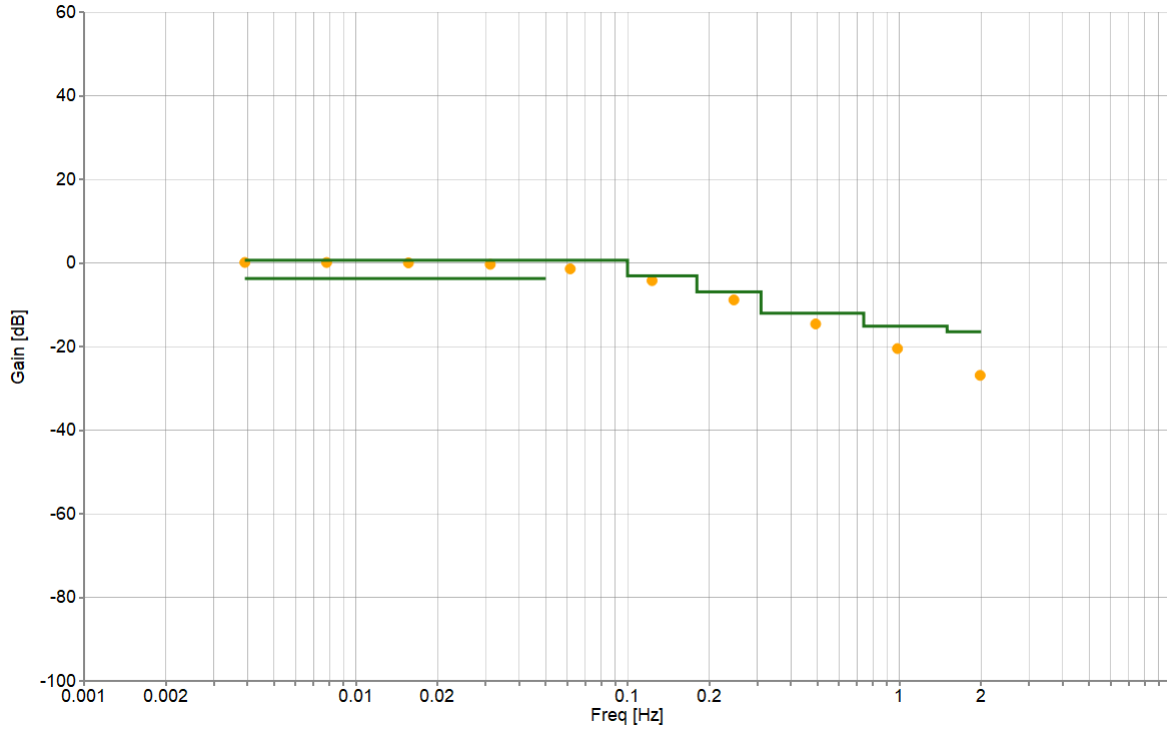

Point #	Freq (Hz)	Ampl (ns)	Duration (s)	Pk-Pk Output (ns)	Gain (dB)	Upper Pk-Pk Limit (ns)	Lower Pk-Pk Limit (ns)
1	0.00390625	200	1024.00	202.34	0.10	215	130
2	0.0078125	200	896.00	202.00	0.09	215	130
3	0.015625	200	448.00	200.01	0.00	215	130
4	0.03125	200	224.00	192.20	-0.35	215	130
5	0.0615625	200	243.65	169.64	-1.43	215	-
6	0.123125	200	251.78	122.66	-4.25	140	-
7	0.24625	200	251.78	72.10	-8.86	90	-
8	0.4925	200	249.75	37.22	-14.61	50	-
9	0.985	200	249.75	18.88	-20.50	35	-
10	1.985	200	249.87	9.03	-26.91	30	-

4.6 G.8273.2: PTP to 1PPS Noise Transfer

According to ITU-T G.8273.3 Section 7.3.1, the output 1PPS signal and 1 PPS signal must correspond to the input physical layer frequency input signal on which a band-pass filter whose lower corner frequency is between 0.05Hz and 0.1Hz and whose upper corner frequency is between 1Hz and 10Hz has been applied. This test checks whether T-BC under evaluation meets this bandpass filter requirement by adding sinusoidal noise on the SyncE (physical layer) input and measuring the output 1PPS noise amplitude.

In this section, the standalone configuration (ts2phc, ptp4l, synced) with physical later assistance (SyncE) is tested for conformance to the Class C standard.

4.6.1 1PPS Measurements

Test Description	PTP to 1PPS Noise Transfer
Report Date	24-09-06_14-57-42
Packet Rate (pkt/s)	16
Beginning of Test	9/5/2024 8:56:39 PM
Test Duration	01:08:20

All Mask Results	Pass
Mask ONEPPS	0.32μs
Mask ONEPPS Result	Pass
Mask PTPNoiseTransfer	G.8273.2 Class C T-BCs Noise Transfer
Mask PTPNoiseTransfer Result	Pass

4.6.1.1 ONEPPS Analysis

Offset Removal Applied	Off
Zero Offset	0.197ns

Date: 2024-09-05
 File: Time Error_06-09-2024_12-16-53.csv
 Offset Removal Applied: False
 Zero Offset: 0.197ns

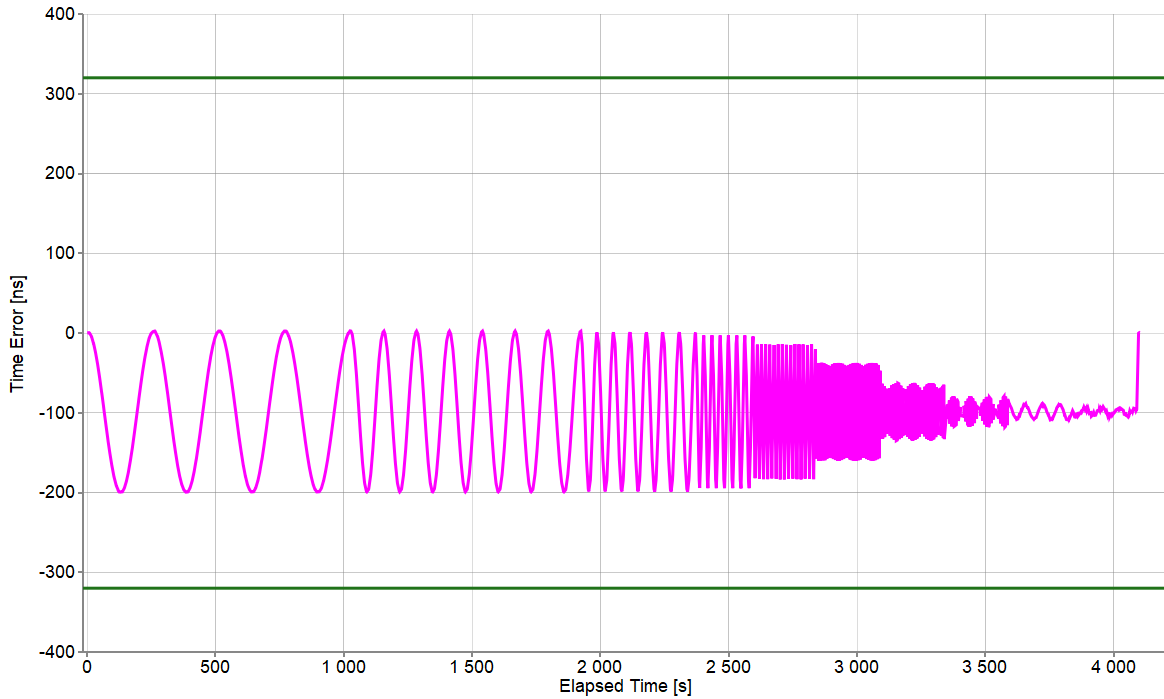

Mean [ns]	-98.549
Min [ns]	-199.553
Max [ns]	2.697
Max-Min [ns]	202.25

4.6.1.2 PTPNoiseTransfer Analysis

Date: 2024-09-05
File: OnePpsAccuracyTod100.CDF

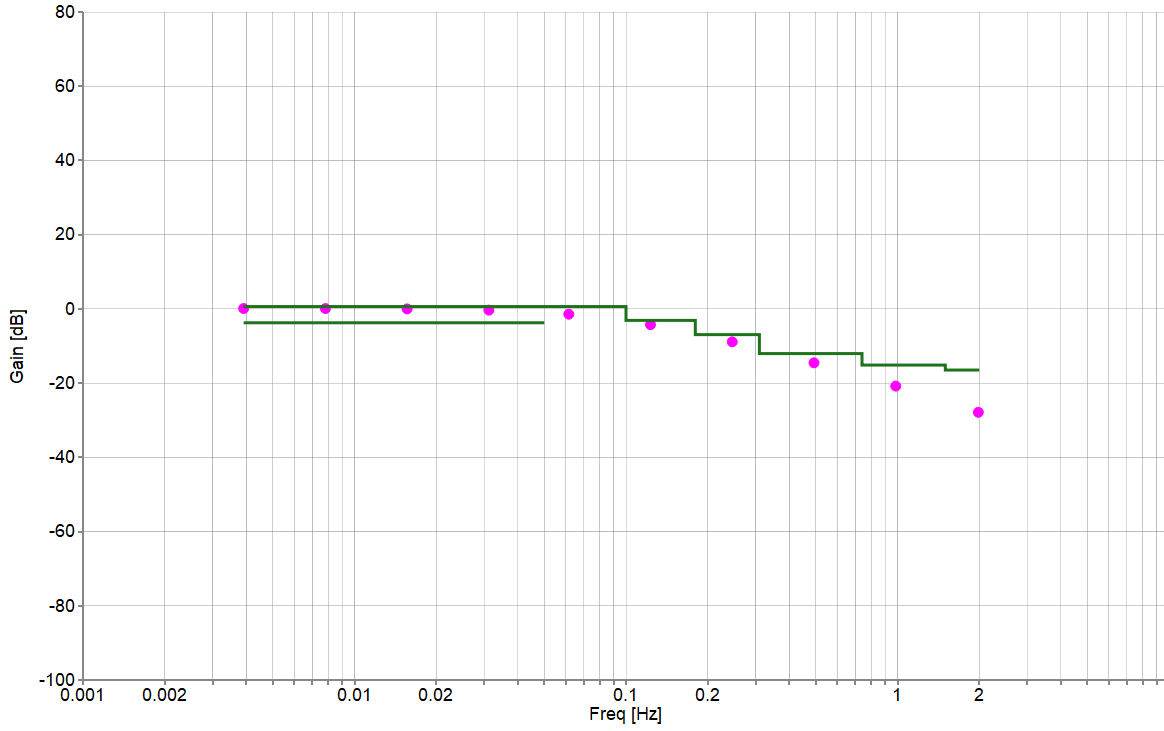

Point #	Freq (Hz)	Ampl (ns)	Duration (s)	Pk-Pk Output (ns)	Gain (dB)	Upper Pk-Pk Limit (ns)	Lower Pk-Pk Limit (ns)
1	0.00390625	200	1024.00	202.40	0.10	215	130
2	0.0078125	200	896.00	202.04	0.09	215	130
3	0.015625	200	448.00	199.88	-0.01	215	130
4	0.03125	200	224.00	192.31	-0.34	215	130
5	0.0615625	200	243.65	169.52	-1.44	215	-
6	0.123125	200	251.78	122.56	-4.25	140	-
7	0.24625	200	251.78	71.92	-8.88	90	-
8	0.4925	200	249.75	37.54	-14.53	50	-
9	0.985	200	249.75	18.24	-20.80	35	-
10	1.985	200	249.87	8.08	-27.87	30	-

4.7 G.8273.2: SyncE Transient

This test emulates a reference switch between physical layer (SyncE) frequency references. A reference switch can generate a large transient on the physical layer and a T-BC must reject this transient. A combination of frequency changes and ESMC messages are used to input the 'worst case' transient based on the SyncE transient pattern shown in ITU-T G.8273. The output PTP and 1PPS of the T-BC must remain within the mask defined by ITU-G.8273.2 Section 7.4.1/Annex C.

In this section, the standalone configuration (ts2phc, ptp4l, synced) with physical later assistance (SyncE) is tested for conformance to the Class C standard using the ITU-T G.8262 (EEC1) SyncE Transient.

4.7.1 PTP Measurements

Test Description	synce_transient_bc
Report Date	24-09-06_14-57-42
Packet Rate (pkt/s)	16
Beginning of Test	9/6/2024 12:14:57 PM
Test Duration	00:08:00

All Mask Results	Pass
Mask TIMEERROR	0.32µs
Mask TIMEERROR Result	Pass
Mask TransientResponse	G.8273.2 Class C Phase Error
Mask TransientResponse Result	Pass

4.7.1.1 TIMEERROR Analysis

Date: 2024-09-06
File: Ptp1588100.CDF
Include Correction Field: True
Packet Selection: False

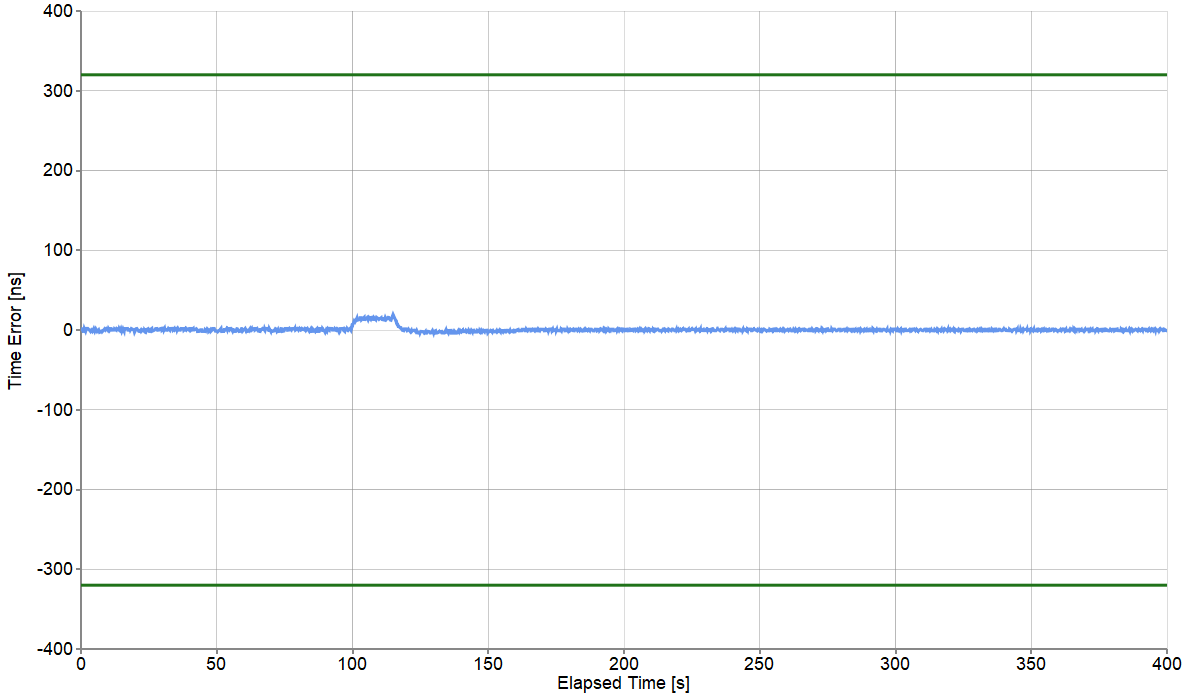

Pk-Pk [ns]	23.5
Mean [ns]	0.498
Min [ns]	-3.956
Max [ns]	19.544

4.7.1.2 TransientResponse Analysis

Date: 2024-09-06
File: Ptp1588100.CDF

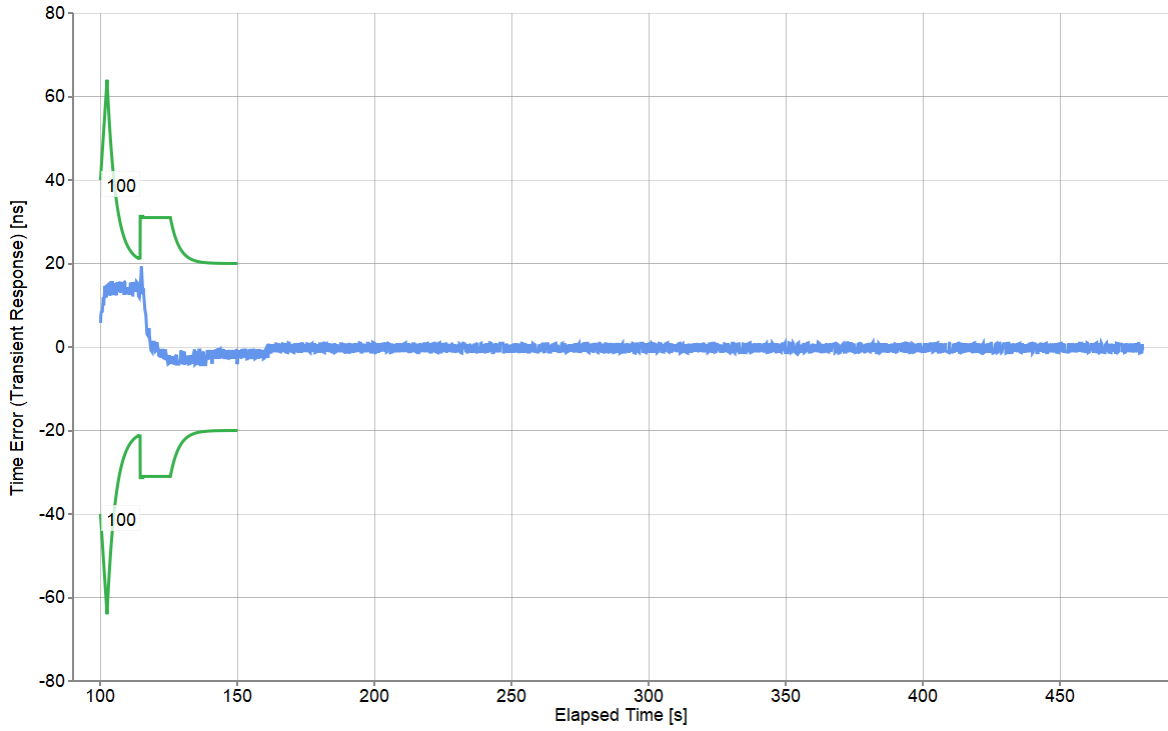

Mean [ns]	0.188
Min [ns]	-4.23
Max [ns]	19.27
Max-Min [ns]	23.5

4.7.2 1PPS Measurements

Test Description	SyncE Transient
Report Date	24-09-06_14-57-42
Packet Rate (pkt/s)	16
Beginning of Test	9/6/2024 12:41:37 PM
Test Duration	00:18:20

All Mask Results	Pass
Mask ONEPPS	0.32µs
Mask ONEPPS Result	Pass
Mask TransientResponse	G.8273.2 Class C Phase Error
Mask TransientResponse Result	Pass

4.7.2.1 ONEPPS Analysis

Offset Removal Applied	Off
Zero Offset	0.947ns

Date: 2024-09-06
 File: OnePpsAccuracyTod100.CDF
 Offset Removal Applied: False
 Zero Offset: 0.947ns

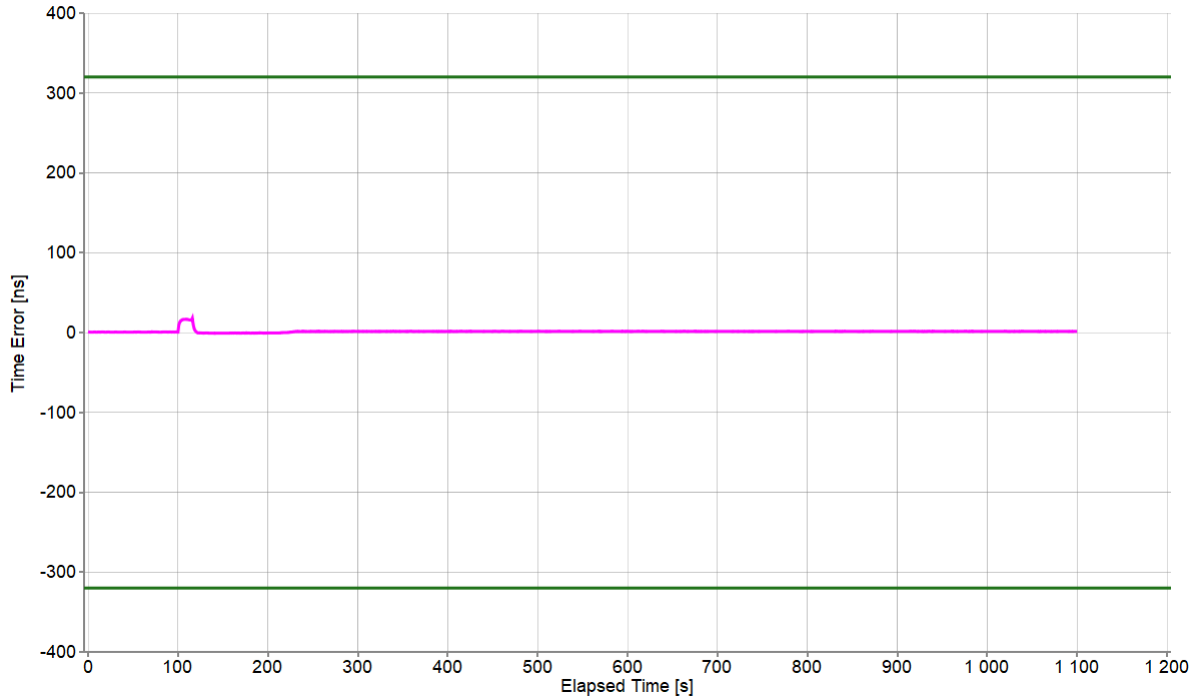

Mean [ns]	1.359
Min [ns]	-1.053
Max [ns]	17.947
Max-Min [ns]	19

4.7.2.2 TransientResponse Analysis

Date: 2024-09-06
 File: OnePpsAccuracyTod100.CDF

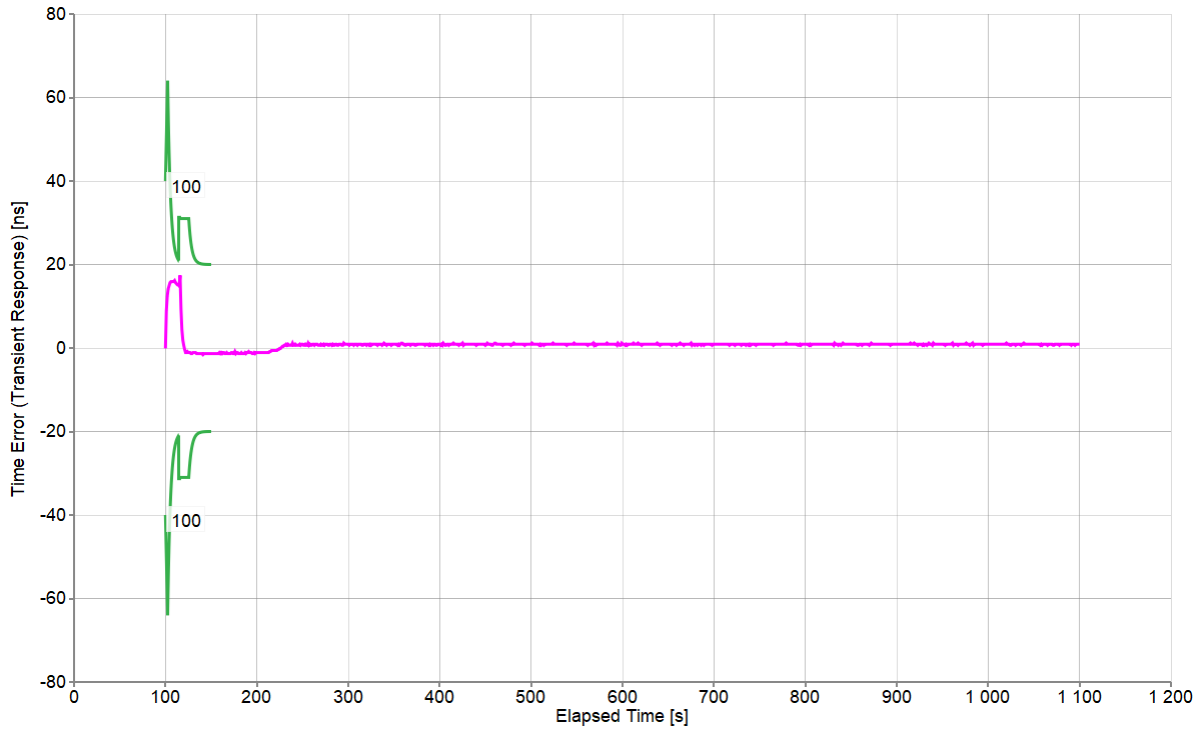

Mean [ns]	0.899
Min [ns]	-1.595
Max [ns]	17.405
Max-Min [ns]	19

4.8 G.8273.2: G.8271.1 Reference Point C PDV

This test checks whether the equipment clock can maintain network limits at the output with maximum noise at the input. The noise tolerance of a clock indicates the minimum time error level at the input of the clock that should be accommodated while: not causing any alarms; not causing the clock to switch reference; not causing the clock to go into holdover.

The level of noise that a PTS device must tolerate on its PTP input is defined according to the network limit defined in ITU-T G.8271.1 clause 7.3.

For this test, the G.8271.1 clause 7.3 PDV pattern is applied to the PTP input and the output 1PPS and PTP performance is observed. The standalone configuration (ts2phc, ptp4l, synced) with physical layer assistance (SyncE) is used during this test.

4.8.1 PTP Measurements

Test Description	G.8271.1 Reference Point C PDV
Report Date	24-09-06_14-57-42
Packet Rate (pkt/s)	16
Beginning of Test	9/6/2024 1:25:21 PM
Test Duration	01:12:38

All Mask Results	Pass
Mask TIMEERROR	1500µs
Mask TIMEERROR Result	Pass

4.8.1.1 TIMEERROR Analysis

Date: 2024-09-06
 File: Ptp1588100.CDF
 Include Correction Field: True
 Packet Selection: False

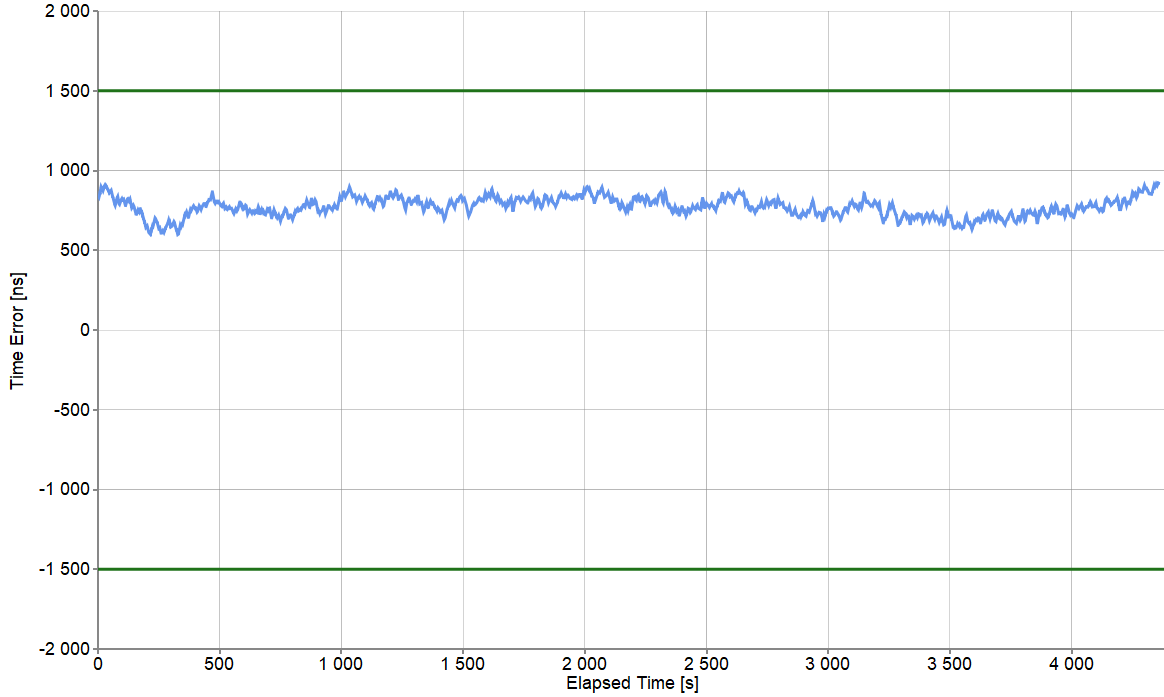

Pk-Pk [ns]	331.625
Mean [ns]	772.311
Min [ns]	598.165
Max [ns]	929.79

4.8.2 1PPS Measurements

Test Description	G.8271.1 Reference Point C PDV
Report Date	24-09-06_14-57-42
Packet Rate (pkt/s)	16
Beginning of Test	9/6/2024 1:25:21 PM
Test Duration	01:12:36

All Mask Results	Pass
Mask ONEPPS	1500µs
Mask ONEPPS Result	Pass

4.8.2.1 ONEPPS Analysis

Offset Removal Applied	Off
Zero Offset	837.697ns

Date: 2024-09-06
 File: OnePpsAccuracyTod100.CDF
 Offset Removal Applied: False
 Zero Offset: 837.697ns

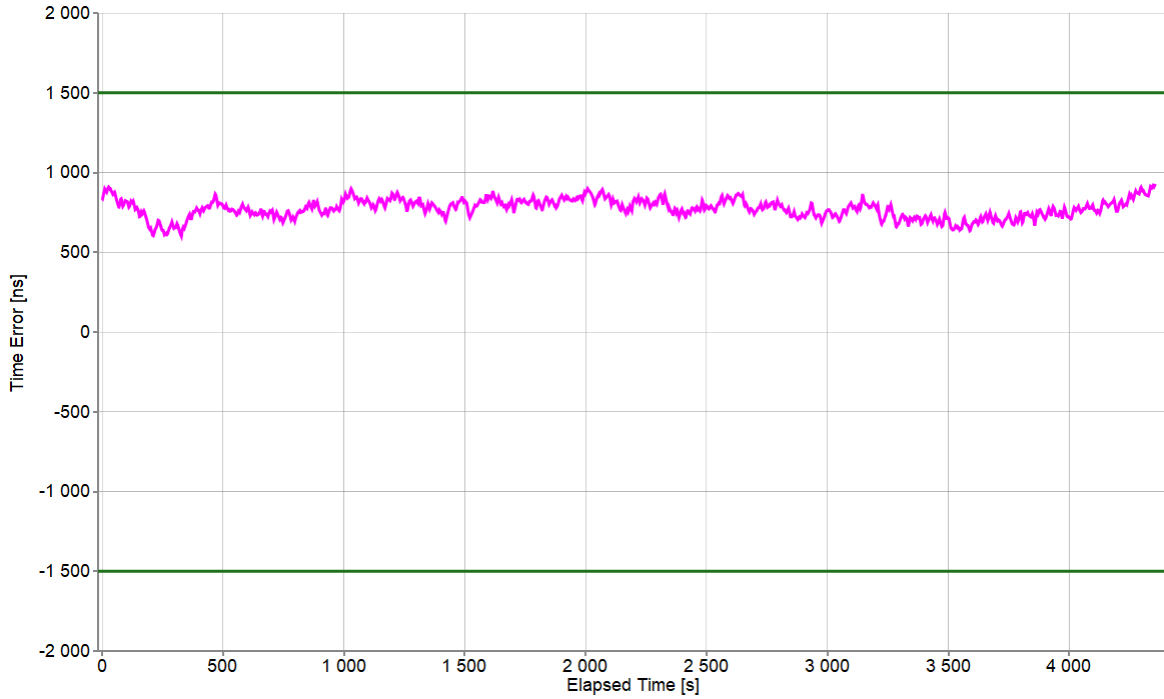

Mean [ns]	773.269
Min [ns]	600.697
Max [ns]	927.947
Max-Min [ns]	327.25

5. External Servo Tests (pcm4l, ptp4l, synced)

5.1 G.8273.2: Noise Generation

The noise generation of a T-BC represents the amount of noise produced at the output of the T-BC when there is an ideal input reference packet timing signal. The noise generation is measured on both the PTP and 1PPS outputs of the DUT.

In this section, the external servo configuration (pcm4l, ptp4l, synced) is tested for conformance to ITU-T G.8273.2 Section 7.1 Class D. Physical layer assistance (SyncE) is used during this test.

5.1.1 PTP Measurements

Test Description	Noise Generation
Report Date	24-09-06_14-57-42
Packet Rate (pkt/s)	16
Beginning of Test	9/6/2024 3:05:22 PM
Test Duration	03:07:59
Time to Phase Lock (s)	10

All Mask Results	Pass
Mask TIMEERROR	0.05 μ s
Mask TIMEERROR Result	Pass
Mask FILTEREDTIMEERROR	0.005 μ s
Mask FILTEREDTIMEERROR Result	Pass
Mask CTE	0.01 μ s
Mask CTE Result	Pass
Mask DTE	0.01 μ s
Mask DTE Result	Pass
Mask DTEHF	0.07 μ s
Mask DTEHF Result	Pass
Mask DTEMTIE	G.8273.2 T-BC Class C Dynamic TE LF Const. Temp.
Mask DTEMTIE Result	Pass
Mask DTETDEV	G.8273.2 T-BC Class C Dynamic TE LF Const. Temp.
Mask DTETDEV Result	Pass

5.1.1.1 TIMEERROR Analysis

Date: 2024-09-06
File: Ptp1588100.CDF
Include Correction Field: True
Packet Selection: False

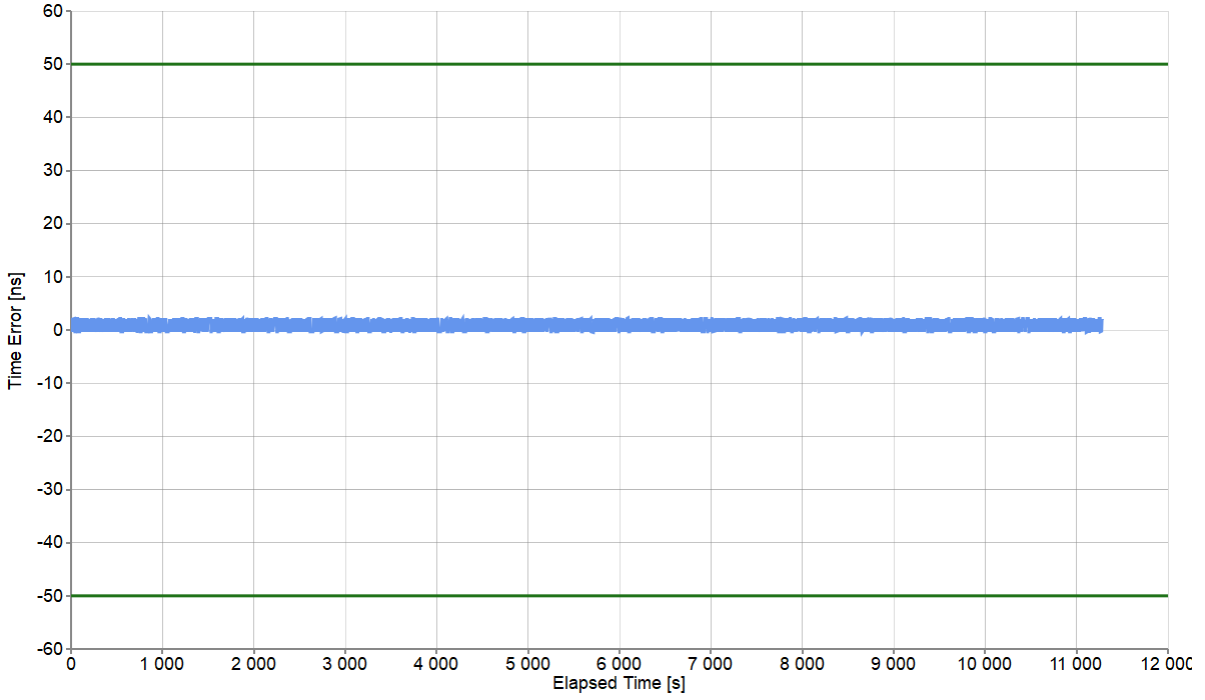

Pk-Pk [ns]	2.75
Mean [ns]	0.908
Min [ns]	-0.464
Max [ns]	2.286

5.1.1.2 FILTEREDTIMEERROR Analysis

Date: 2024-09-06
File: Ptp1588100.CDF

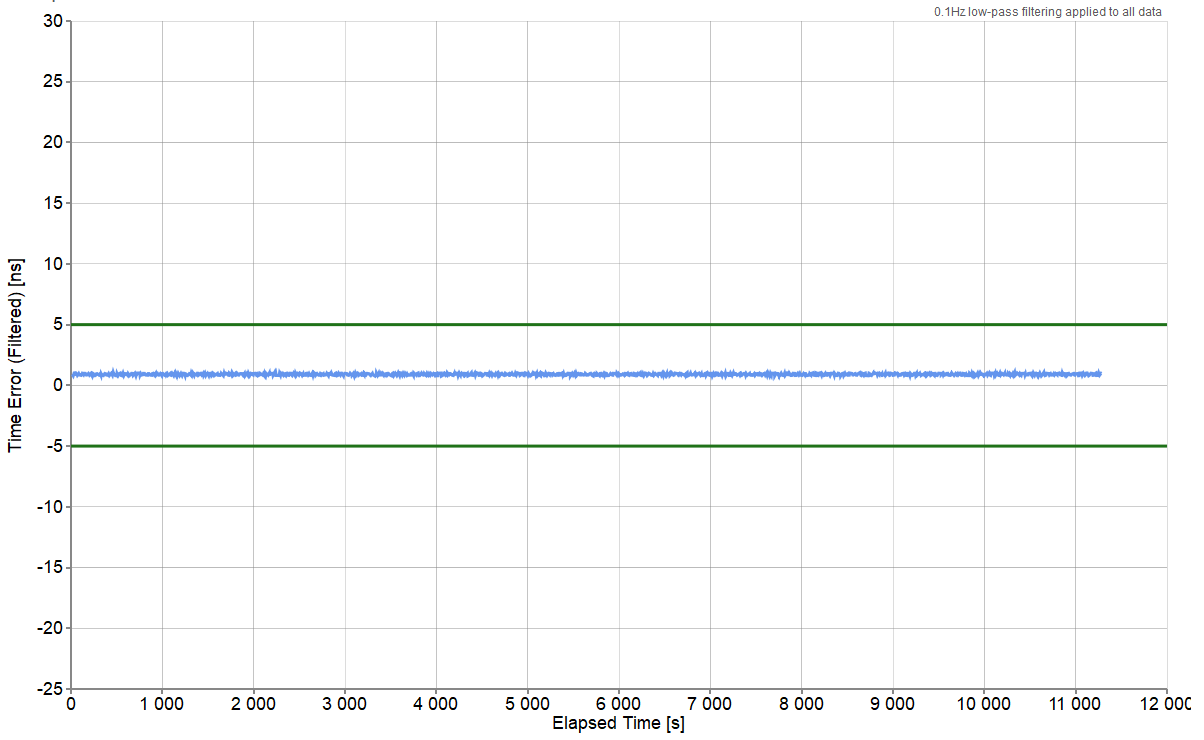

Mean [ns]	0.908
Min [ns]	0.725
Max [ns]	1.087
Max-Min [ns]	0.362

5.1.1.3 CTE Analysis

Date: 2024-09-06
 File: Ptp1588100.CDF
 Averaging Period: 1000s

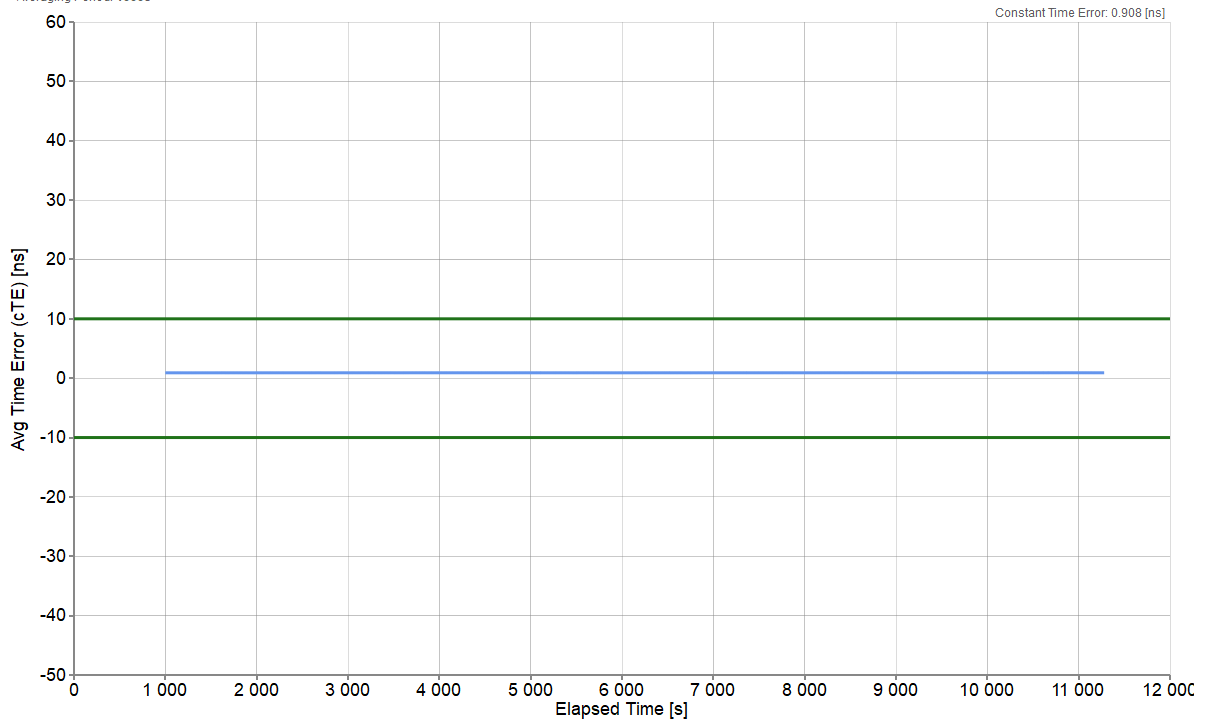

Averaging Time (s)	1000
Constant Time Error [ns]	0.908
Min [ns]	0.903
Max [ns]	0.912
Max-Min [ns]	0.01

5.1.1.4 DTE Analysis

Date: 2024-09-06
File: Ptp1588100.CDF
Remove Setting: True
Normalization: True

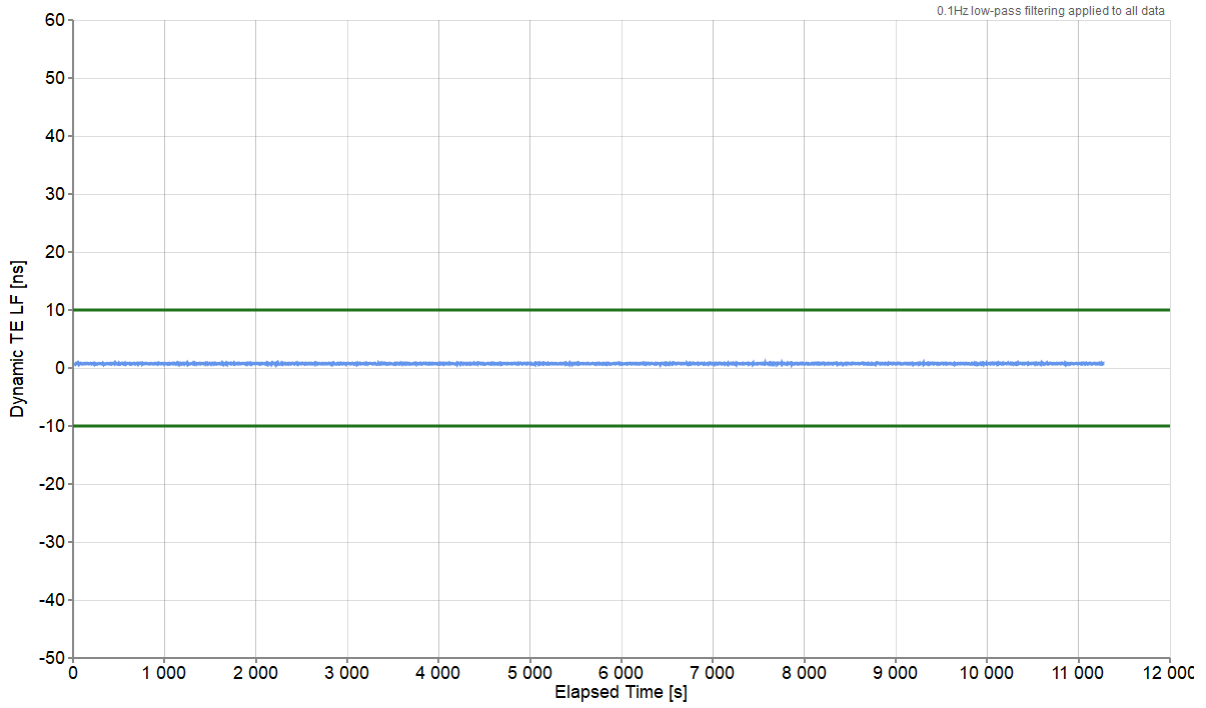

Mean [ns]	0.747
Min [ns]	0.564
Max [ns]	0.926
Max-Min [ns]	0.362

5.1.1.5 DTEHF Analysis

Date: 2024-09-06
File: Ptp1588100.CDF
Normalization: True

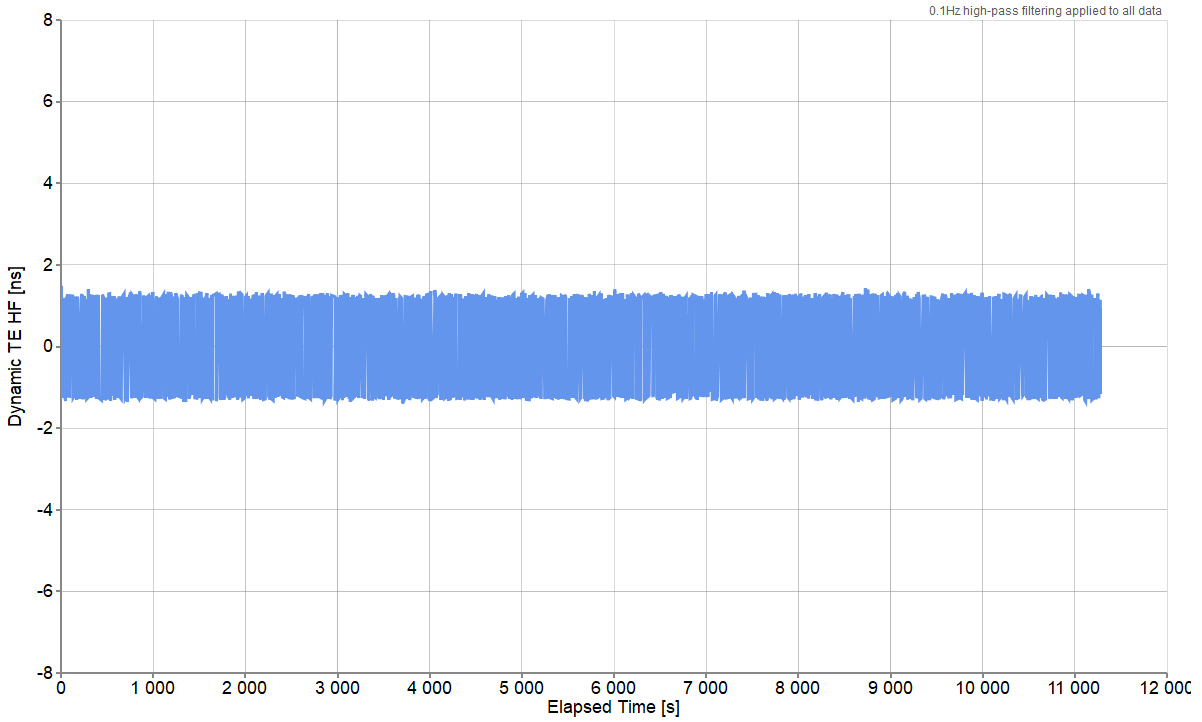

Pk-Pk [ns]	2.876
Mean [ns]	0
Min [ns]	-1.393
Max [ns]	1.483

5.1.1.6 DTEMTIE Analysis

Date: 2024-09-06
File: Ptp1588100.CDF

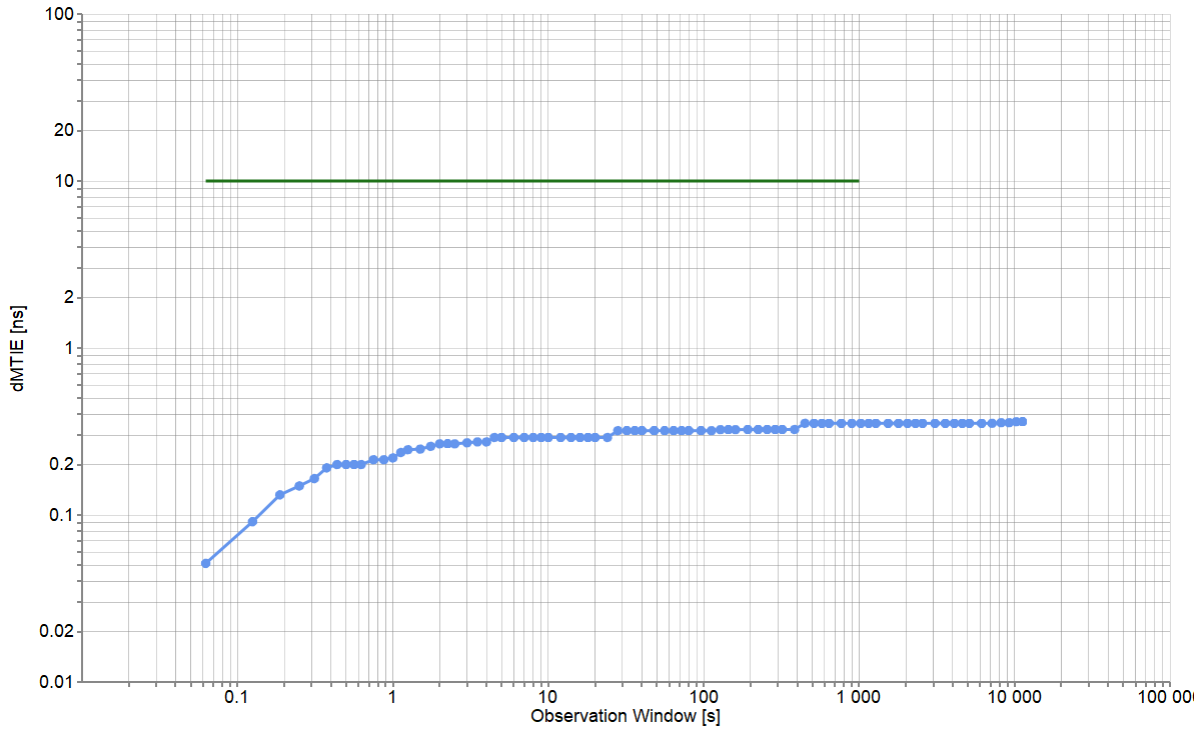

Min [ns]	0.051
Max [ns]	0.362
Max-Min [ns]	0.31

5.1.1.7 DTETDEV Analysis

Date: 2024-09-06
 File: Ptp1588100.CDF

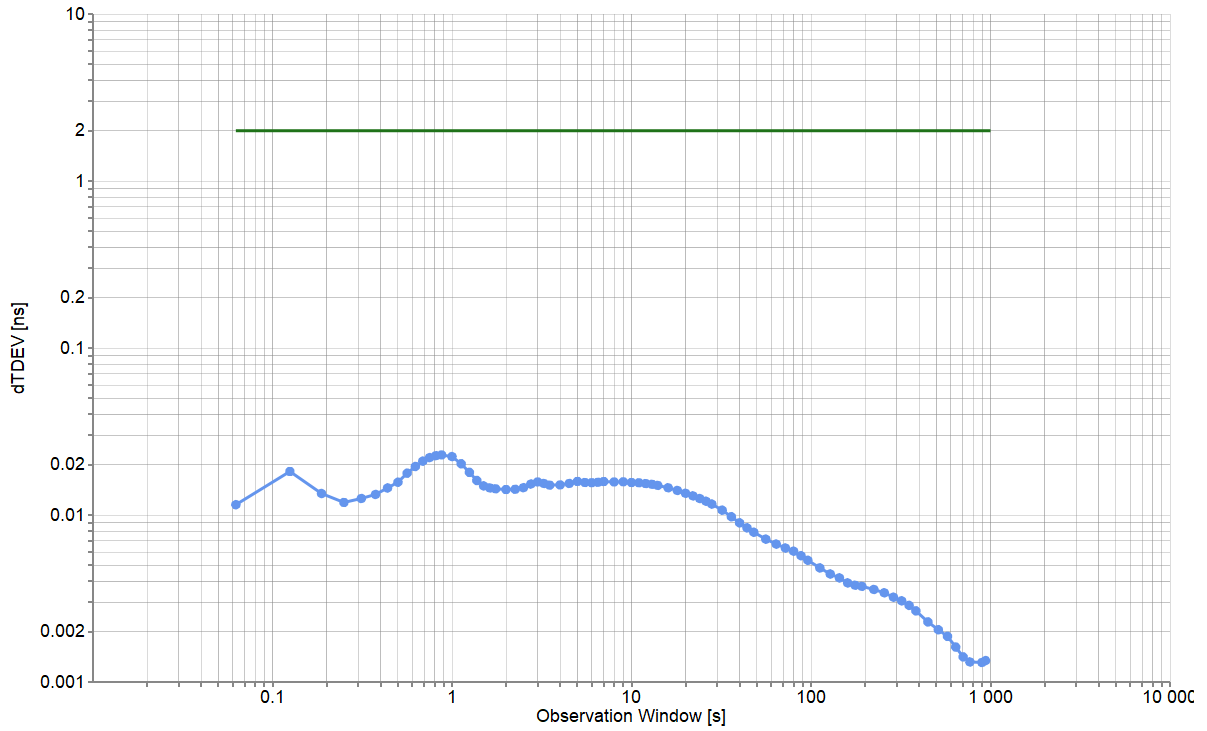

Min [ns]	0.001
Max [ns]	0.023
Max-Min [ns]	0.022

5.1.2 1PPS Measurements

Test Description	Noise Generation
Report Date	24-09-06_14-57-42
Packet Rate (pkt/s)	16
Beginning of Test	9/6/2024 3:05:22 PM
Test Duration	03:07:58
Time to Phase Lock (s)	10

All Mask Results	Pass
Mask ONEPPS	0.03µs
Mask ONEPPS Result	Pass
Mask FILTEREDTIMEERROR	0.005µs
Mask FILTEREDTIMEERROR Result	Pass
Mask CTE	0.01µs
Mask CTE Result	Pass
Mask DTE	0.01µs
Mask DTE Result	Pass
Mask DTEHF	0.07µs
Mask DTEHF Result	Pass
Mask DTEMTIE	G.8273.2 T-BC Provisional Class D Dynamic TE LF Const. Temp.
Mask DTEMTIE Result	Pass
Mask DTETDEV	G.8273.2 T-BC Provisional Class D Dynamic TE LF Const. Temp.
Mask DTETDEV Result	Pass

5.1.2.1 ONEPPS Analysis

Offset Removal Applied	Off
Zero Offset	1.447ns

Date: 2024-09-06
 File: OnePpsAccuracyTod100.CDF
 Offset Removal Applied: False
 Zero Offset: 1.447ns

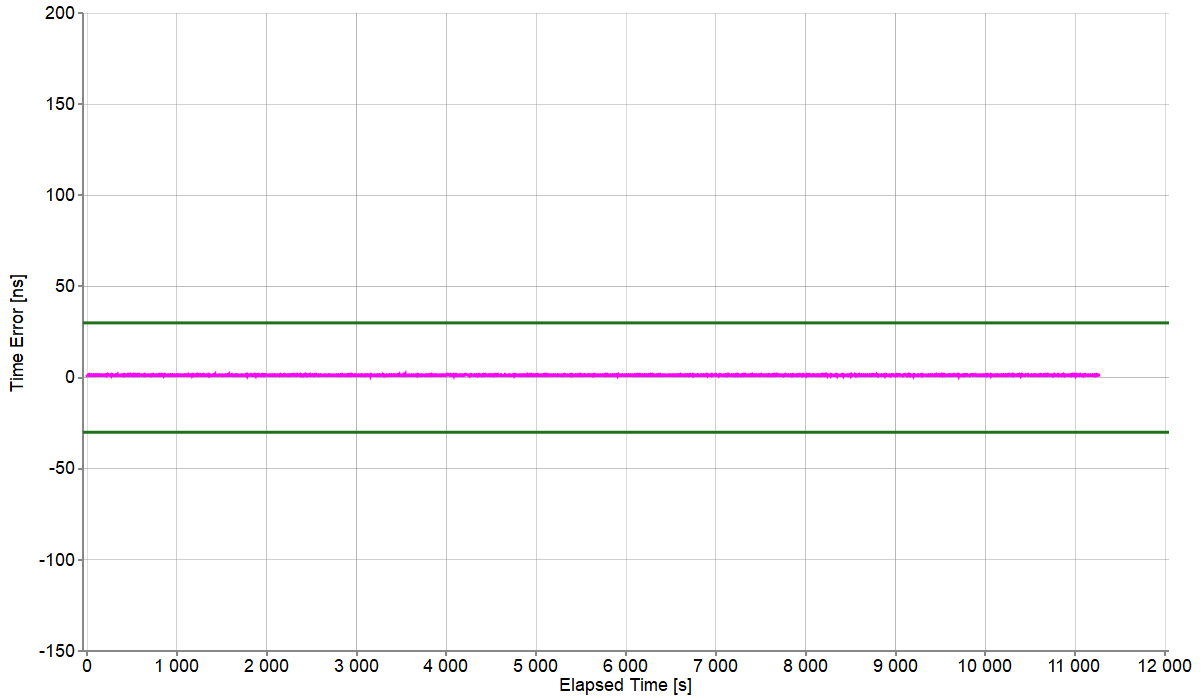

Mean [ns]	1.331
Min [ns]	1.197
Max [ns]	1.697
Max-Min [ns]	0.5

5.1.2.2 FILTEREDTIMEERROR Analysis

Date: 2024-09-06
 File: OnePpsAccuracyTod100.CDF

0.1Hz low-pass filtering applied to all data

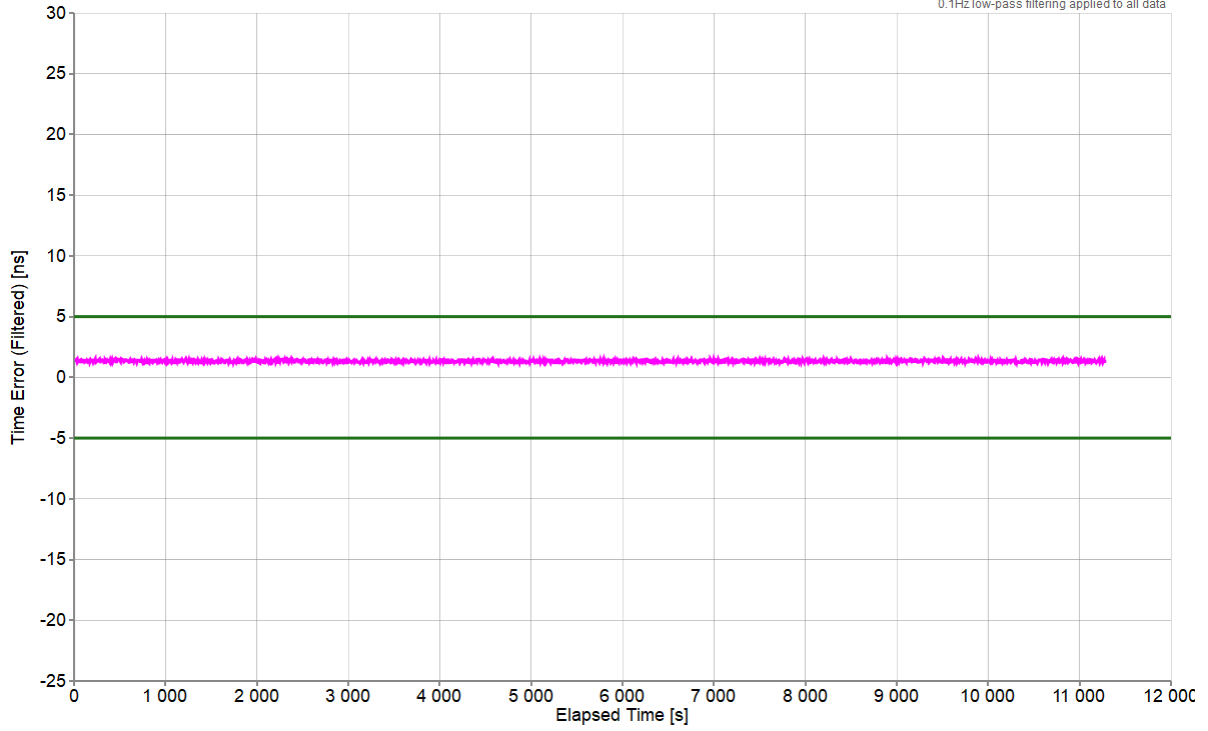

Mean [ns]	1.331
Min [ns]	1.197
Max [ns]	1.6
Max-Min [ns]	0.403

5.1.2.3 CTE Analysis

Date: 2024-09-06
 File: OnePpsAccuracyTod100.CDF
 Averaging Period: 1000s

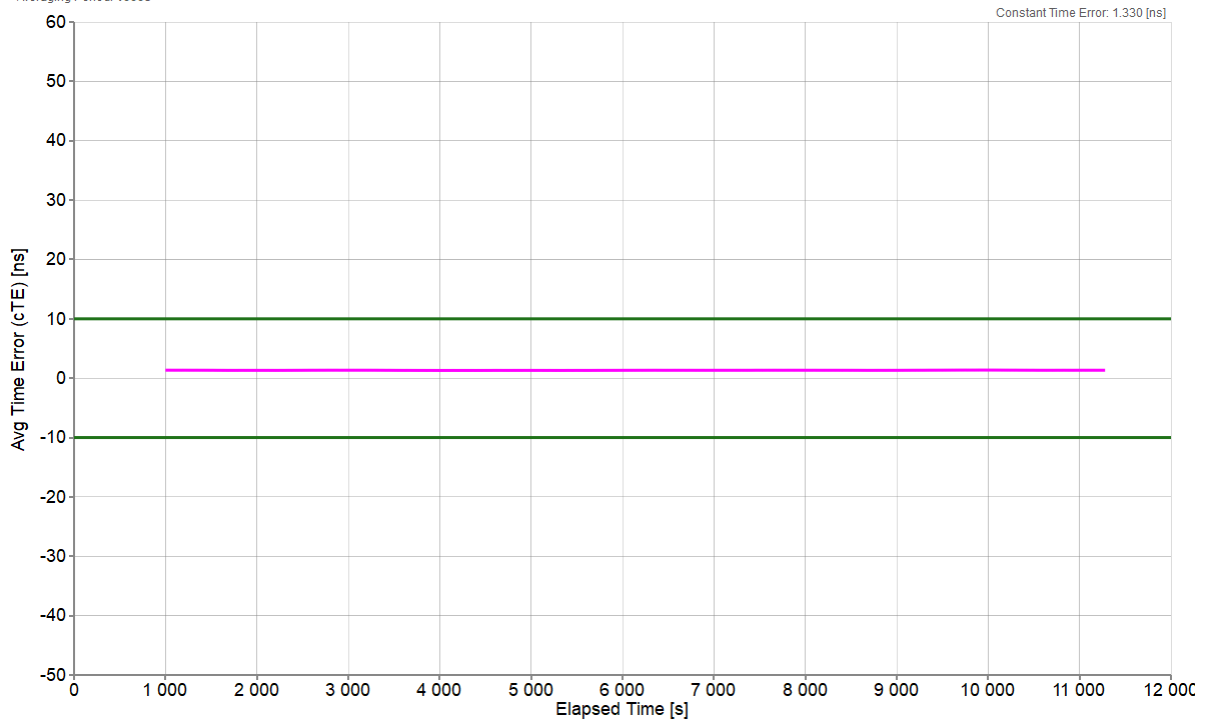

Averaging Time (s)	1000
Constant Time Error [ns]	1.33
Min [ns]	1.302
Max [ns]	1.367
Max-Min [ns]	0.065

5.1.2.4 DTE Analysis

Date: 2024-09-06
 File: OnePpsAccuracyTod100.CDF
 Remove Settling: True
 Normalization: True

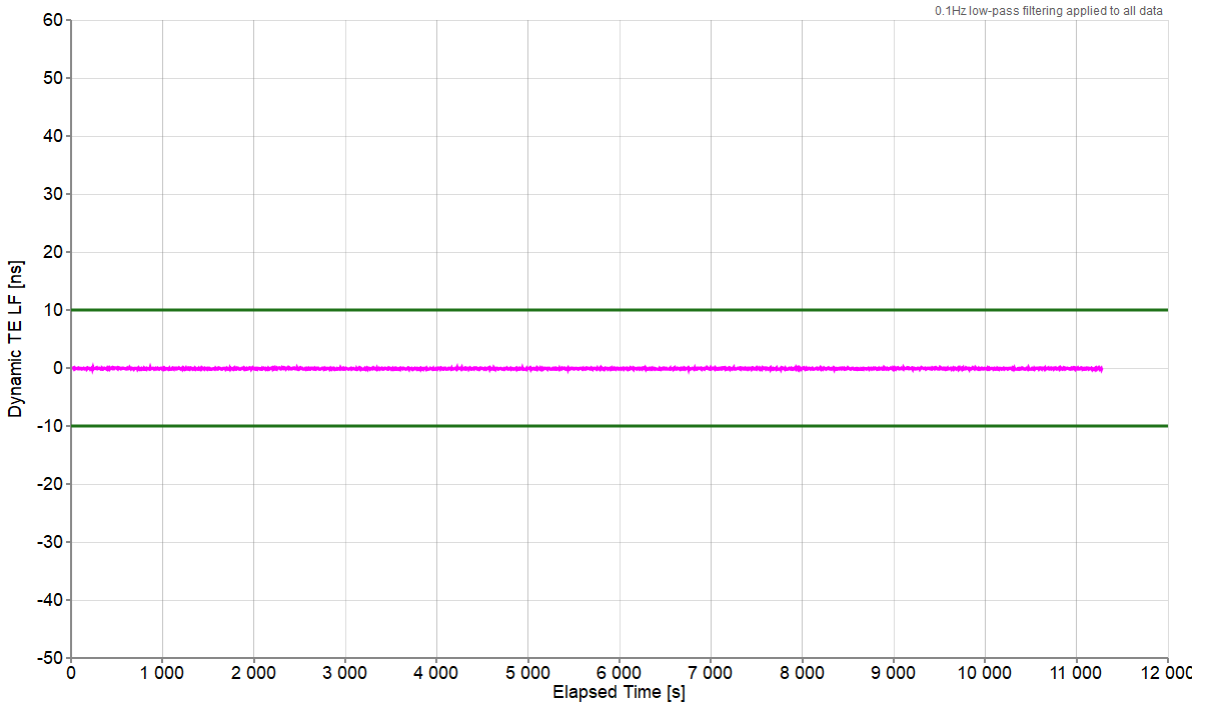

Mean [ns]	-0.116
Min [ns]	-0.25
Max [ns]	0.153
Max-Min [ns]	0.403

5.1.2.5 DTEHF Analysis

Date: 2024-09-06
File: OnePpsAccuracyTod100.CDF
Normalization: True

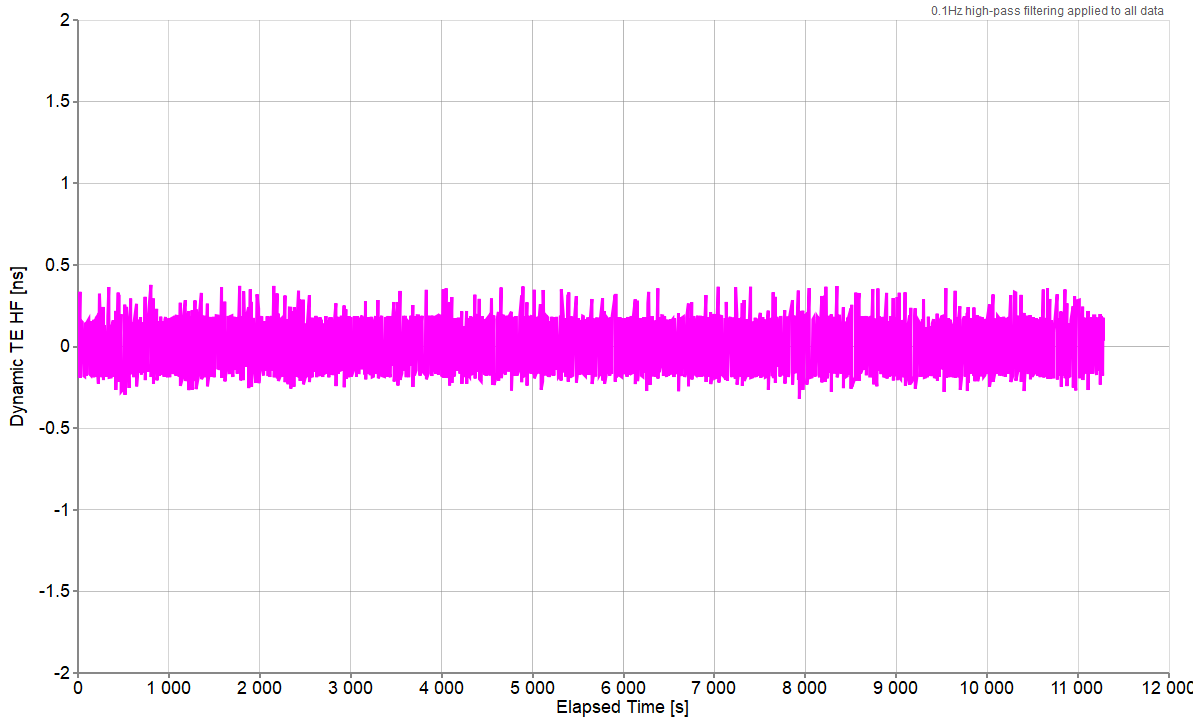

Mean [ns]	0
Min [ns]	-0.321
Max [ns]	0.377
Max-Min [ns]	0.698

5.1.2.6 DTEMTIE Analysis

Date: 2024-09-06
 File: OnePpsAccuracyTod100.CDF

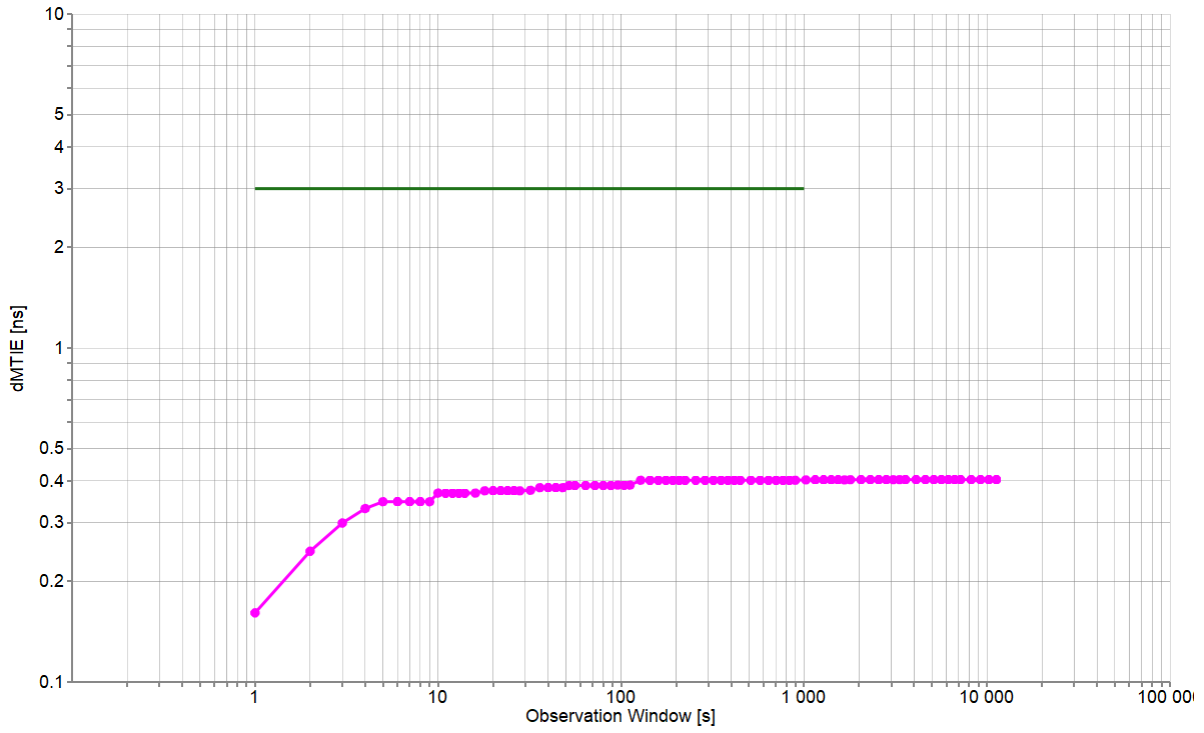

Min [ns]	0.161
Max [ns]	0.403
Max-Min [ns]	0.242

5.1.2.7 DTETDEV Analysis

Date: 2024-09-06
 File: OnePpsAccuracyTod100.CDF

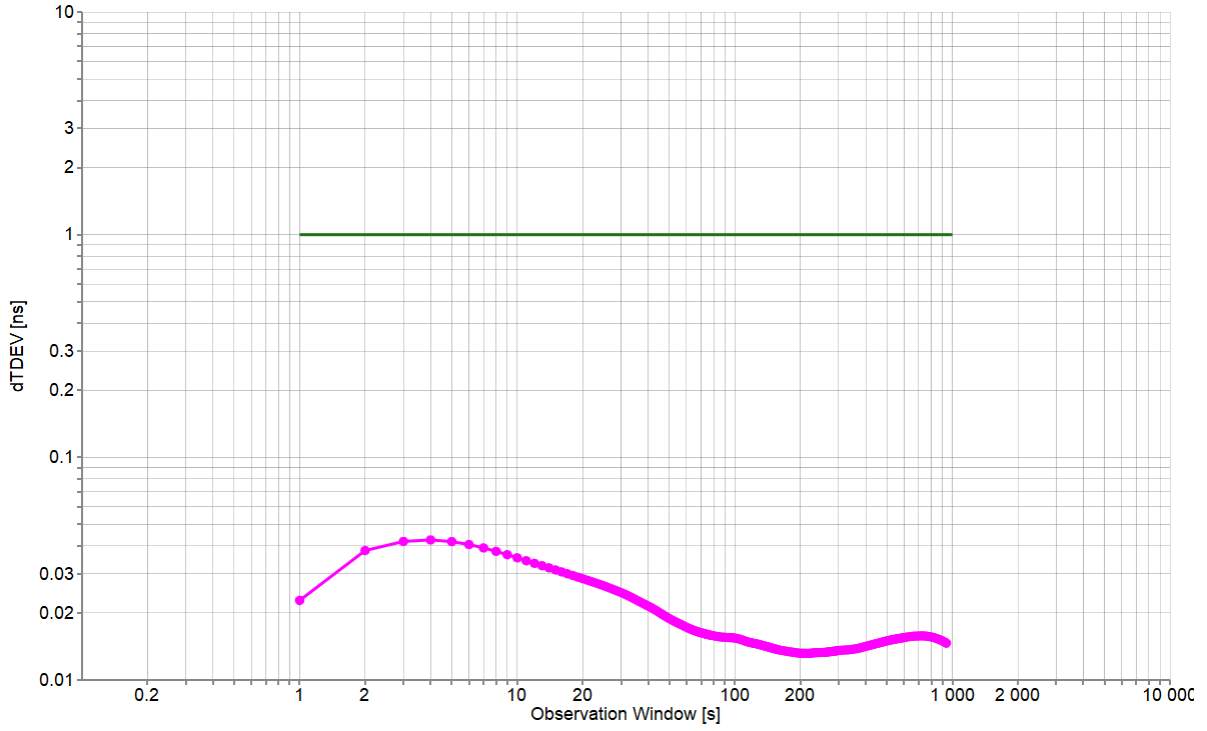

Min [ns]	0.013
Max [ns]	0.043
Max-Min [ns]	0.029

5.2 G.8273.2: Holdover

Holdover performance is checked by measuring the phase/time output in the event of the loss of the PTP input to the T-BC. The holdover performance is measured on PTP and 1PPS outputs of the DUT.

In this section, the external servo configuration (pcm4l, ptp4l, synced) is tested for conformance to ITU-T G.8273.2 Section 7.1 Class D. Physical layer assistance (SyncE) is used during this test.

5.2.1 PTP Measurements

Test Description	Holdover
Report Date	24-09-09_08-03-38
Packet Rate (pkt/s)	16
Beginning of Test	9/6/2024 8:56:58 PM
Test Duration	62:31:01

All Mask Results	Pass
Mask TIMEERROR	N/A
Mask TIMEERROR Result	NoMask
Mask DTE	N/A
Mask DTE Result	NoMask
Mask DTEMTIE	G.8273.2 T-BC Class B Time Holdover Const. Temp.
Mask DTEMTIE Result	Pass

5.2.1.1 TIMEERROR Analysis

Date: 2024-09-06
 File: Ptp1588100.CDF
 Include Correction Field: True
 Packet Selection: False

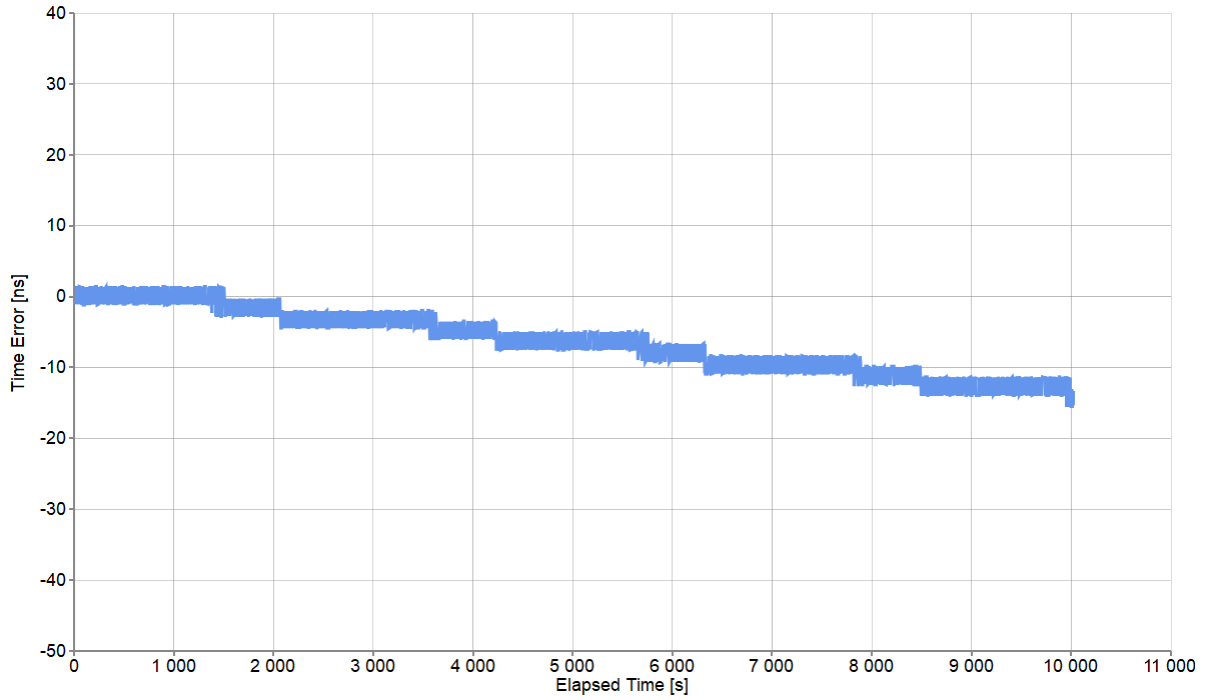

Pk-Pk [ns]	17.125
Mean [ns]	-6.423
Min [ns]	-15.698
Max [ns]	1.427

5.2.1.2 DTE Analysis

Date: 2024-09-06
 File: Ptp1588100.CDF
 Remove Settling: True
 Normalization: True

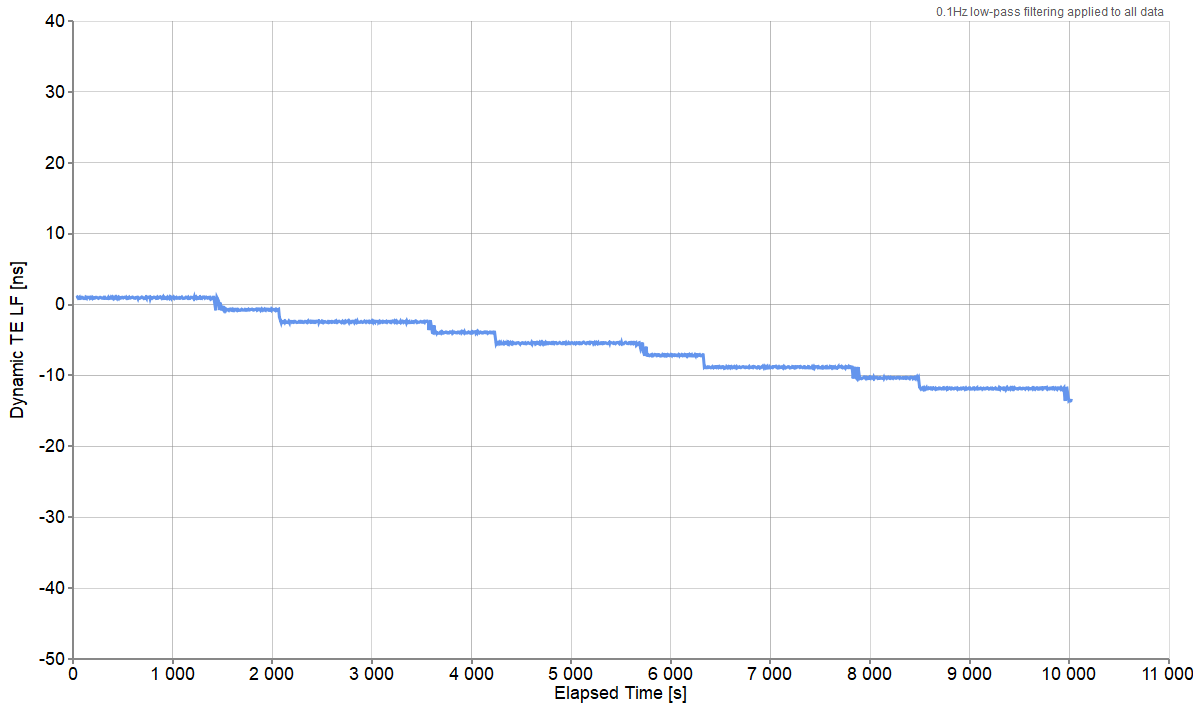

Mean [ns]	-5.608
Min [ns]	-13.617
Max [ns]	1.104
Max-Min [ns]	14.721

5.2.1.3 DTEMTIE Analysis

Date: 2024-09-06
File: Ptp1588100.CDF

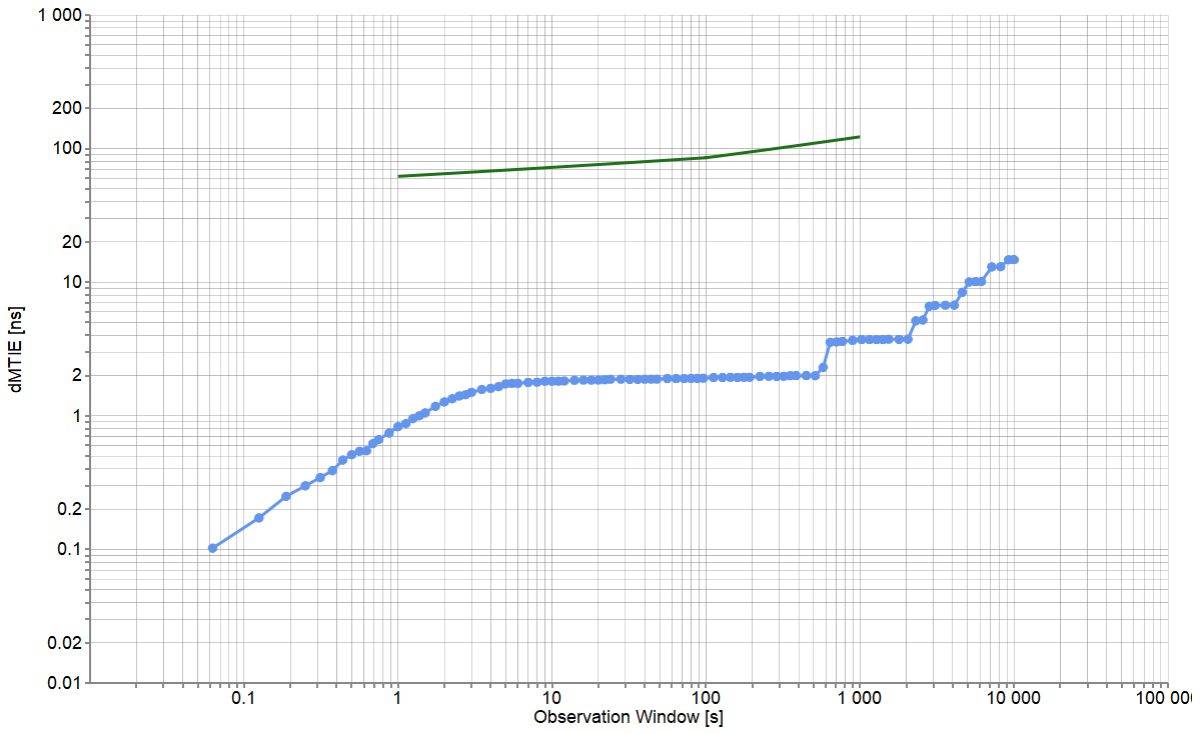

Min [ns]	0.102
Max [ns]	14.721
Max-Min [ns]	14.619

5.2.2 1PPS Measurements

Test Description	holdover
Report Date	24-09-09_08-03-38
Packet Rate (pkt/s)	16
Beginning of Test	9/6/2024 8:56:58 PM
Test Duration	02:46:40

All Mask Results	Pass
Mask ONEPPS	N/A
Mask ONEPPS Result	NoMask
Mask MTIE	G.8273.2 T-BC Class B Time Holdover Const. Temp.
Mask MTIE Result	Pass

5.2.2.1 ONEPPS Analysis

Offset Removal Applied	Off
Zero Offset	-2.803 ns

Date: 2024-09-06
 File: Time Error_09-09-2024_08-02-55.csv
 Offset Removal Applied: False
 Zero Offset: -2.803ns

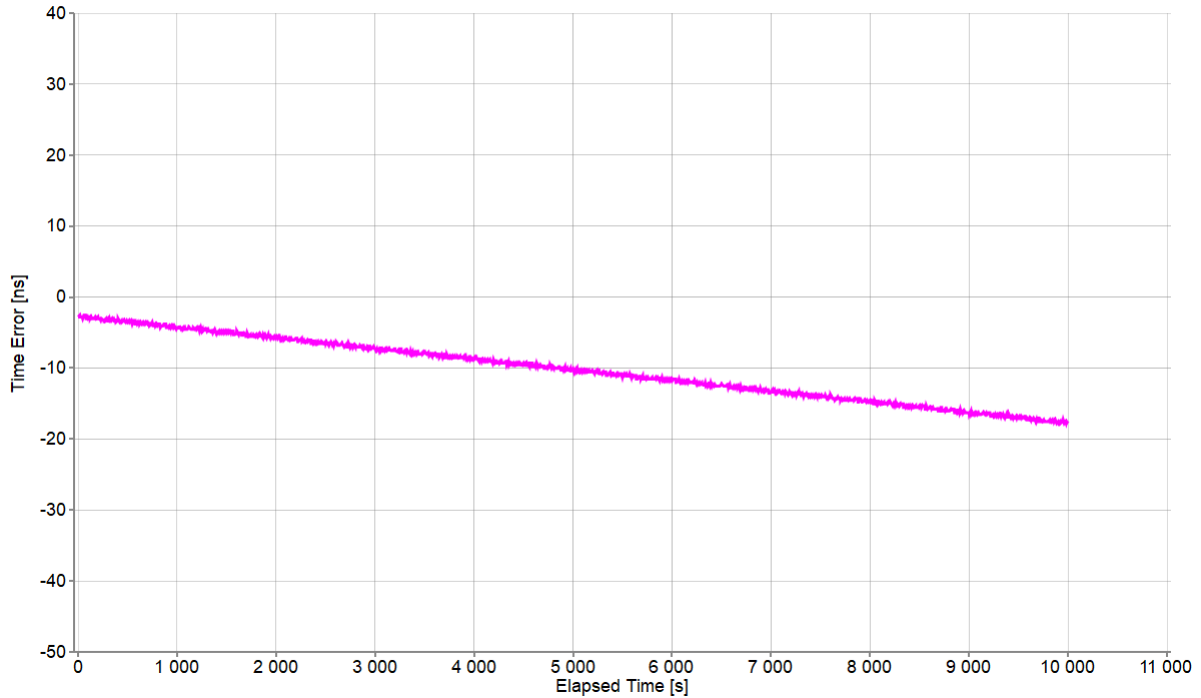

Mean [ns]	-10.299
Min [ns]	-17.803
Max [ns]	-2.553
Max-Min [ns]	15.25

5.2.2.2 MTIE Analysis

Date: 2024-09-06
 File: Time Error_09-09-2024_08-02-55.csv

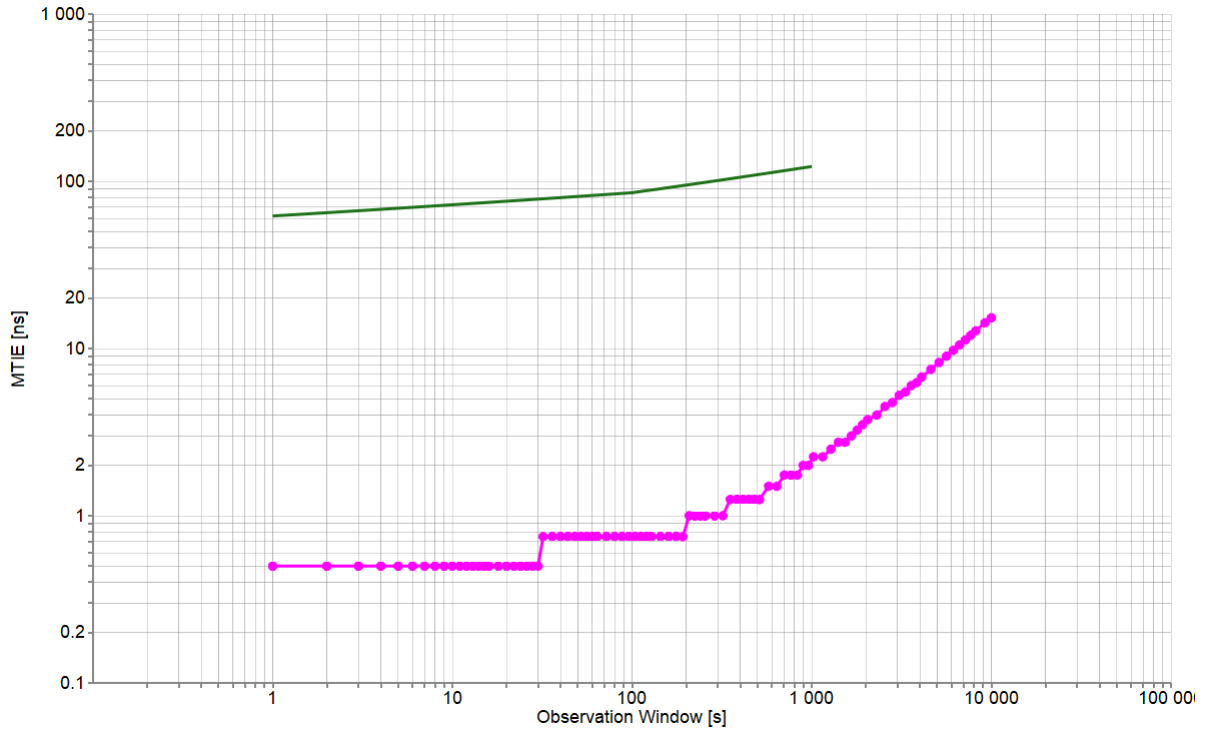

Min [ns]	0.5
Max [ns]	15.25
Max-Min [ns]	14.75

5.3 G.8273.2: SyncE to PTP Noise Transfer

According to ITU-T G.8273.2 Section 7.3.2, the output PTP signal and 1 PPS signal must correspond to the input physical layer frequency input signal on which a band-pass filter whose lower corner frequency is between 0.05Hz and 0.1Hz and whose upper corner frequency is between 1Hz and 10Hz has been applied. This test checks whether T-BC under evaluation meets this bandpass filter requirement by adding sinusoidal noise on the SyncE (physical layer) input and measuring the output PTP noise amplitude.

In this section, the external servo configuration (pcm4l, ptp4l, synced) with physical later assistance (SyncE) is tested for conformance.

5.3.1 PTP Measurements

Test Description	SyncE to PTP Noise Transfer
Report Date	24-09-06_16-56-06
Packet Rate (pkt/s)	16
Beginning of Test	9/6/2024 7:20:38 PM
Test Duration	01:16:45
Time to Phase Lock (s)	8

All Mask Results	Pass
Mask TIMEERROR	0.32µs
Mask TIMEERROR Result	Pass
Mask SyncENoiseTransfer	G.8273.2 Class C T-BCs Noise Transfer
Mask SyncENoiseTransfer Result	Pass

5.3.1.1 TIMEERROR Analysis

Date: 2024-09-06
 File: Ptp1588100.CDF
 Include Correction Field: True
 Packet Selection: False

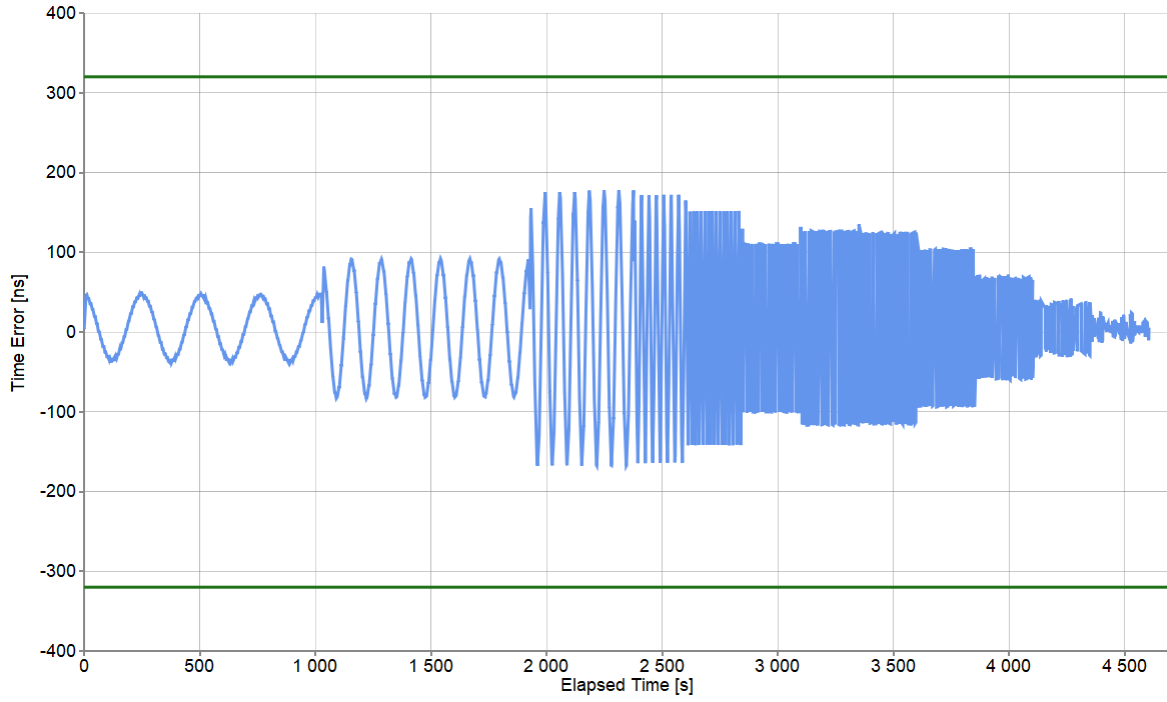

Pk-Pk [ns]	345.75
Mean [ns]	4.81
Min [ns]	-167.954
Max [ns]	177.796

5.3.1.2 SyncNoiseTransfer Analysis

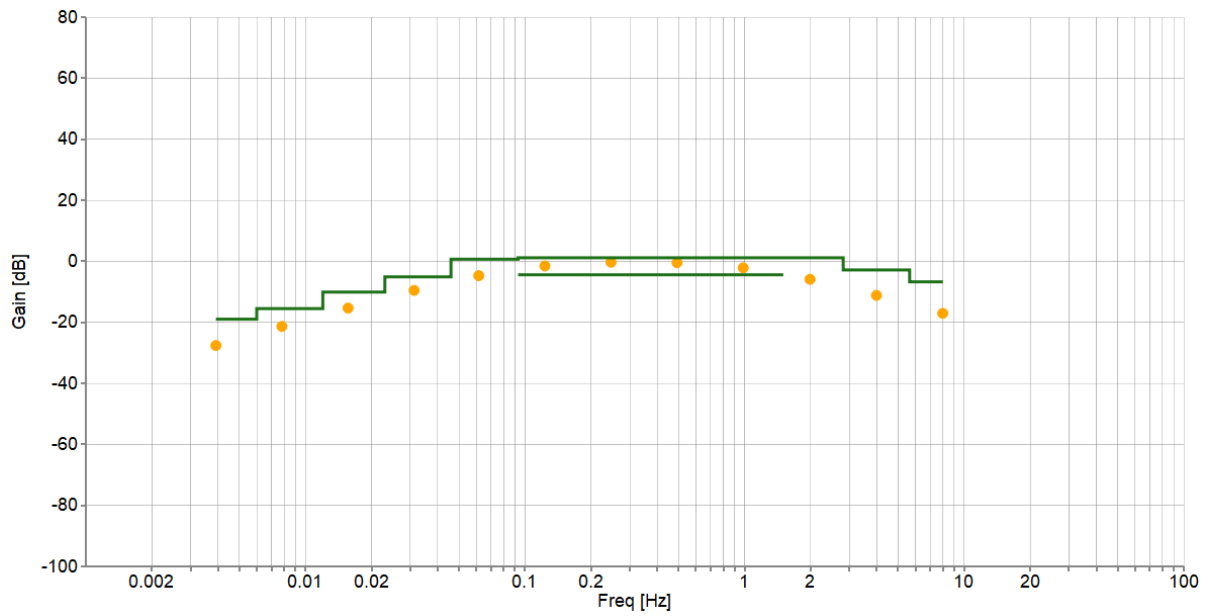

Point #	Freq (Hz)	Ampl (ns)	Duration (s)	Pk-Pk Output (ns)	Gain (dB)	Upper Pk-Pk Limit (ns)	Lower Pk-Pk Limit (ns)
1	0.00391	2000	1023.02	83.06	-27.63	225	-
2	0.00781	2000	896.29	171.05	-21.36	340	-
3	0.01563	2000	447.86	341.71	-15.35	630	-
4	0.03125	1000	224.00	333.55	-9.54	565	-
5	0.06156	500	243.66	290.01	-4.73	545	-
6	0.12313	250	251.77	209.29	-1.54	285	150
7	0.24625	250	251.78	241.07	-0.32	285	150
8	0.4925	250	249.75	236.80	-0.47	285	150
9	0.985	250	249.75	195.31	-2.14	285	150
10	1.985	250	249.87	126.64	-5.91	285	-
11	3.985	250	249.94	68.87	-11.20	285	-
12	7.985	250	249.97	34.97	-17.08	285	-

5.4 G8273.2: SyncE to 1PPS Noise Transfer

According to ITU-T G.8273.2 Section 7.3.3, the output 1PPS signal and 1 PPS signal must correspond to the input physical layer frequency input signal on which a band-pass filter whose lower corner frequency is between 0.05Hz and 0.1Hz and whose upper corner frequency is between 1Hz and 10Hz has been applied. This test checks whether T-BC under evaluation meets this bandpass filter requirement by adding sinusoidal noise on the SyncE (physical layer) input and measuring the output 1PPS noise amplitude.

In this section, the external servo configuration (pcm4l, ptp4l, synced) with physical later assistance (SyncE) is tested for conformance.

5.4.1 1PPS Measurements

Test Description	SyncE to 1PPS Noise Transfer
Report Date	24-09-06_16-56-06
Packet Rate (pkt/s)	16
Beginning of Test	9/6/2024 7:20:38 PM
Test Duration	01:16:42
Time to Phase Lock (s)	8

All Mask Results	Pass
Mask ONEPPS	0.32μs
Mask ONEPPS Result	Pass
Mask SyncENoiseTransfer	G.8273.2 Class C T-BCs Noise Transfer
Mask SyncENoiseTransfer Result	Pass

5.4.1.1 ONEPPS Analysis

Offset Removal Applied	Off
Zero Offset	8.697ns

Date: 2024-09-06
 File: OnePpsAccuracyTod100.CDF
 Offset Removal Applied: False
 Zero Offset: 8.697ns

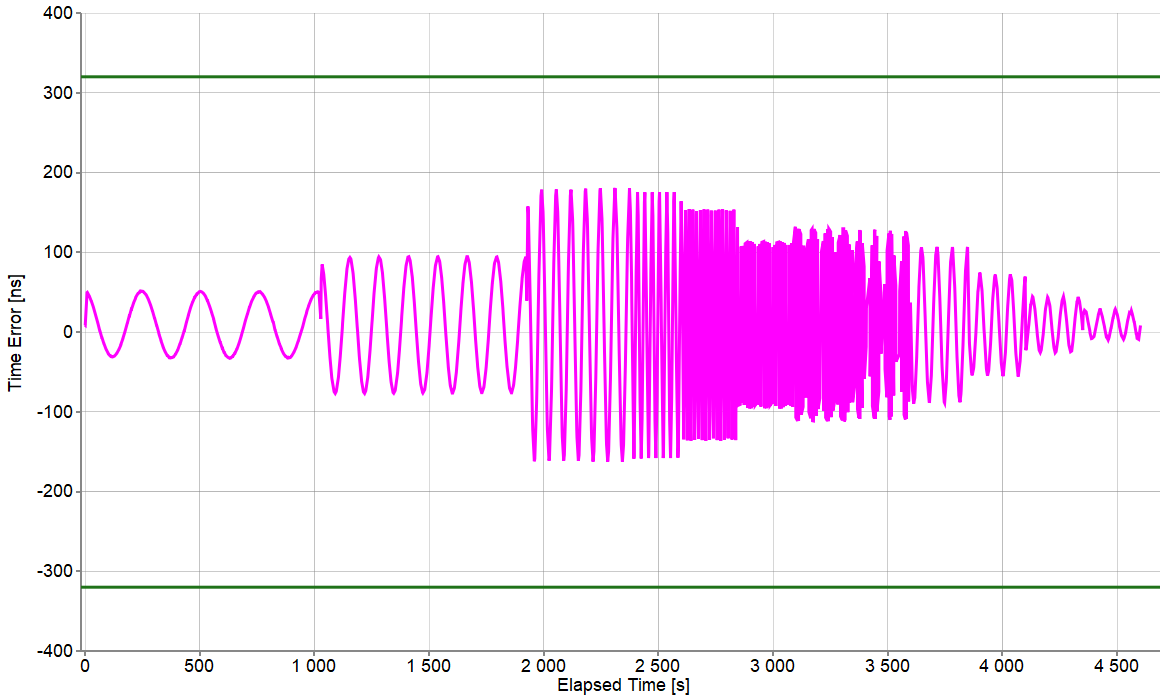

Mean [ns]	8.704
Min [ns]	-162.553
Max [ns]	180.447
Max-Min [ns]	343

5.4.1.2 SyncNoiseTransfer Analysis

Date: 2024-09-06
File: OnePpsAccuracyTod100.CDF

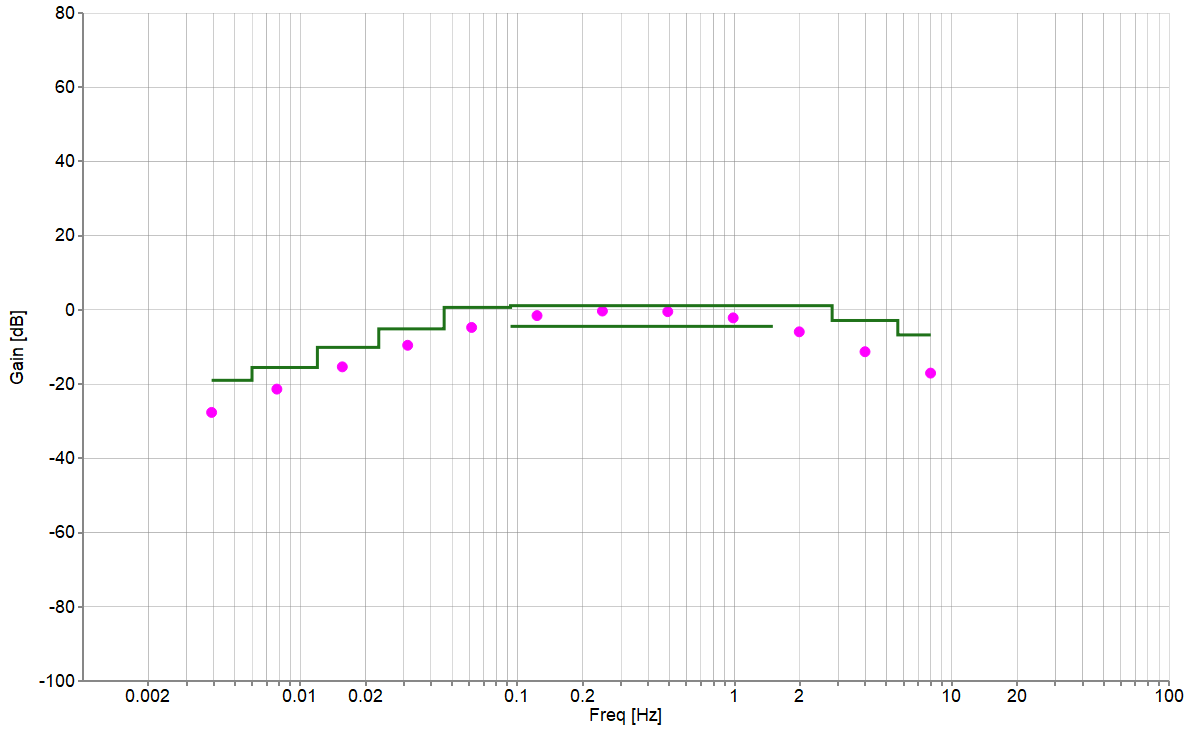

Point #	Freq (Hz)	Ampl (ns)	Duration (s)	Pk-Pk Output (ns)	Gain (dB)	Upper Pk-Pk Limit (ns)	Lower Pk-Pk Limit (ns)
1	0.00391	2000	1023.02	83.10	-27.63	225	-
2	0.00781	2000	896.29	171.25	-21.35	340	-
3	0.01563	2000	447.86	341.68	-15.35	630	-
4	0.03125	1000	224.00	333.54	-9.54	565	-
5	0.06156	500	243.66	289.95	-4.73	545	-
6	0.12313	250	251.77	209.29	-1.54	285	150
7	0.24625	250	251.78	241.22	-0.31	285	150
8	0.4925	250	249.75	236.83	-0.47	285	150
9	0.985	250	249.75	195.16	-2.15	285	150
10	1.985	250	249.87	126.58	-5.91	285	-
11	3.985	250	249.94	68.28	-11.27	285	-
12	7.985	250	249.97	35.17	-17.04	285	-

6. Configuration Files

6.1 TCS File

The TCS file comes loaded with the ZCU670 image: ZCU670_8A34001_synced_2024aug16_10G.tcs.

6.2 Ts2phc cfg File

```
#
# ts2phc config file to get it to behave like syncd to align
# timestamper to PHC device's 1 PPS signal.
#
# Example:
# ./ts2phc -m -q -f ts2phc.cfg
#

[global]
clock_servo          nullf
first_step_threshold 0.000000001
step_threshold       0.000000001

# timestamper, slave device
[/dev/ptp1]
ts2phc.channel       0
ts2phc.extts_correction -511

# PHC device (ex. CM), master device
# Set ts2phc.channel to 2 for Sabre
# Set ts2phc.channel to 0 for FC3/W
[/dev/ptp0]
ts2phc.master        1
ts2phc.channel        0
```

6.3 Standalone ptp4l cfg File

```
#
# Telecom G.8275.1 T-TSC example configuration containing those attributes
# which either differ from the defaults or are relevant to the profile.
#
[global]
domainNumber      24

# Announce messages
announceReceiptTimeout  3
logAnnounceInterval     -3

delayAsymmetry  4

# Sync/Delay_Req/Delay_Resp messages - 16 packets-per-second, -4 = 16 PPS
logSyncInterval      -4
logMinDelayReqInterval -4

# step_window is in units of sync packets
# 3 seconds:
# @ 16 PPS, set to 48
# @ 1 PPS, set to 3
step_window          48

clockClass           255
clockAccuracy        0xFE
timeSource           0xa0
maxStepsRemoved     255

offsetScaledLogVariance 0xffff

G.8275.defaultDS.localPriority 128
G.8275.portDS.localPriority    128
priority1                      128
priority2                      255

dataset_comparison      G.8275.x
transportSpecific       0
clock_type              BC
delay_mechanism         E2E

first_step_threshold    0.000020000
step_threshold          0.000020000
tx_timestamp_timeout    1000

write_phase_mode        1
servo_offset_threshold 250
servo_num_offset_values 64
tsproc_mode             raw

network_transport       L2
```

```
# 01:1B:19:00:00:00    Forwardable multi-cast address
# 01:80:C2:00:00:0E    Non-forwardable multi-cast address
ptp_dst_mac           01:1B:19:00:00:00
```

```
[eth1]
[eth2]
```

6.4 External Servo ptp4l cfg File

```
#
# PCM4L
#
# Telecom G.8275.1 T-TSC example configuration containing those attributes
# which either differ from the defaults or are relevant to the profile.
#
[global]
domainNumber      24

# Announce messages
announceReceiptTimeout  3
logAnnounceInterval    -3

# Sync/Delay_Req/Delay_Resp messages - 16 packets-per-second, -4 = 16 PPS
logSyncInterval        -4
logMinDelayReqInterval -4

slaveOnly      0
masterOnly     0

clockClass      248
clockAccuracy   0xFE
timeSource      0xa0
maxStepsRemoved 255

offsetScaledLogVariance 0xffff

G.8275.defaultDS.localPriority 128
G.8275.portDS.localPriority    128

priority1      128
priority2      255

dataset_comparison      G.8275.x
transportSpecific       0

clock_type      BC
delay_mechanism E2E

#
# Send timestamps to pcm4l
#
free_running      1
```

```
slave_event_monitor    /var/run/pcm4l
tsproc_mode            raw
tx_timestamp_timeout   5
sanity_freq_limit      0

network_transport      L2

# 01:1B:19:00:00:00     Forwardable multi-cast address
# 01:80:C2:00:00:0E     Non-forwardable multi-cast address
ptp_dst_mac            01:1B:19:00:00:00

[eth1]
[eth2]
```

6.5 Pcm4l json File

```
{
  "versionId": "0.0",
  "testModeEnable": 0,
  "referenceTrackerType": "WritePhase",
  "remoteUdsAddress": "/var/run/ptp4l",
  "localUdsAddress": "/var/run/pcm4l",

  "stepWindowSeconds": 1,

  "phc4lConfig":
  {
    "dcoDevice": "/dev/ptp0",
    "tsDevice":
    [
      {
        "tsDeviceName": "/dev/ptp1",
        "tsDevicePinIndex": -1,
        "tsDeviceExtttsChannel": 0,
        "tsDeviceExtttsCorrectionNs": -512
      }
    ],
    "charDevice": "/dev/rsmu0",

    "phaseSnapDelaySeconds": 3,
    "tsCalibrationEnable": 0
  },

  "deviceConfig":
  {
    "oscillatorType": "Tcxo",
    "dpll1588Instance": 2,
    "tsDeviceAlignmentDisable": 0,
    "holdover":
    {
      "holdoverType": "HardwareEnhanced",
```

```

        "holdoverLossPhysicalOosEnable": 0,
        "holdoverTimeoutSeconds": 1000,
        "holdoverQualificationSeconds": 1000,
        "unqualifiedTimeoutSeconds": 10000,
        "outOfSpecUserDefinedFrequencyOffsetEnable": 0,
        "outOfSpecUserDefinedFrequencyOffsetPpb": 0
    }
},

"profileConfig":
{
    "physicalPllClockCategory": 4,
    "physicalPllClockCategoryThreshold": 1,
    "physicalPllInstance": 0,
    "physicalPllWaitToRestoreTimeoutValue": 10
},

"loggerConfig":
{
    "stdoutLog":
    {
        "enable": 1,
        "selectionMask": "0000000000111111",
        "_description_": "          | |||||___ 0: Sync error          ",
        "_description_": "          | |||||___ 1: Sync warning          ",
        "_description_": "          | ||||___ 2: Sync analysis          ",
        "_description_": "          | |||___ 3: Error          ",
        "_description_": "          | ||___ 4: Warning          ",
        "_description_": "          | |___ 5: Debug          ",
        "_description_": "          |___ 7: Timestamp          "
    },

    "externalFdLog":
    {
        "enable": 0,
        "selectionMask": "0000000000111111",
        "_description_": "          | |||||___ 0: Sync error          ",
        "_description_": "          | |||||___ 1: Sync warning          ",
        "_description_": "          | ||||___ 2: Sync analysis          ",
        "_description_": "          | |||___ 3: Error          ",
        "_description_": "          | ||___ 4: Warning          ",
        "_description_": "          | |___ 5: Debug          ",
        "_description_": "          |___ 7: Timestamp          "
    }
},

"instanceConfig":
[
    {
        "correctionFieldEnable": 1,
        "lostMasterTimeoutMilliseconds": 2000,
        "manageClockClassExtendedEnable": 0,
        "numberOfTrackerInstances": 1,
    }
]

```

```
"trackerConfig":  
  {  
    "delayAsymmetryNanoseconds": 0,  
    "phaseSnapThresholdSeconds": 0.00001,  
    "floorDelayEstimateSeconds": -1.0,  
    "timeLockThresholdNanoseconds": 250,  
    "willCorrectFrequencyAtFirstSnap": 1,  
    "frequencyLockThresholdPpb": 16.0,  
    "lockFilterWindowLengthSeconds": 1.0  
  }  
]  
}
```

6.6 Synced cfg File

```
#
# Global parameters
#
[global]
net_opt 1
no_ql_en 0
synce_forced_ql_en 1
lo_ql SEC
lo_pri 255
max_msg_lvl 6
stdout_en 1
syslog_en 0
# Device configuration file path (applicable for generic device)
device_cfg_file ""
device_name /dev/rsmu0
synce_dp11_idx 0
holdover_ql SEC
holdover_tmr 10
hoff_tmr 300
wtr_tmr 10
advanced_holdover_en 0
pcm41_if_en 1
pcm41_if_ip_addr 127.0.0.1
pcm41_if_port_num 2400
mng_if_en 1
mng_if_ip_addr 127.0.0.2
mng_if_port_num 2401

#
# Sync-E clock port
#
[eth1]
clk_idx 1
pri 1
tx_en 1
rx_en 1
tx_bundle_num -1
init_ql SEC

[eth2]
#clk_idx 1
pri 2
tx_en 1
rx_en 1
tx_bundle_num -1
init_ql SEC
```

7. Revision History

Revision	Date	Description
1.00	Dec 11, 2024	Initial release.

IMPORTANT NOTICE AND DISCLAIMER

RENESAS ELECTRONICS CORPORATION AND ITS SUBSIDIARIES (“RENESAS”) PROVIDES TECHNICAL SPECIFICATIONS AND RELIABILITY DATA (INCLUDING DATASHEETS), DESIGN RESOURCES (INCLUDING REFERENCE DESIGNS), APPLICATION OR OTHER DESIGN ADVICE, WEB TOOLS, SAFETY INFORMATION, AND OTHER RESOURCES “AS IS” AND WITH ALL FAULTS, AND DISCLAIMS ALL WARRANTIES, EXPRESS OR IMPLIED, INCLUDING, WITHOUT LIMITATION, ANY IMPLIED WARRANTIES OF MERCHANTABILITY, FITNESS FOR A PARTICULAR PURPOSE, OR NON-INFRINGEMENT OF THIRD-PARTY INTELLECTUAL PROPERTY RIGHTS.

These resources are intended for developers who are designing with Renesas products. You are solely responsible for (1) selecting the appropriate products for your application, (2) designing, validating, and testing your application, and (3) ensuring your application meets applicable standards, and any other safety, security, or other requirements. These resources are subject to change without notice. Renesas grants you permission to use these resources only to develop an application that uses Renesas products. Other reproduction or use of these resources is strictly prohibited. No license is granted to any other Renesas intellectual property or to any third-party intellectual property. Renesas disclaims responsibility for, and you will fully indemnify Renesas and its representatives against, any claims, damages, costs, losses, or liabilities arising from your use of these resources. Renesas' products are provided only subject to Renesas' Terms and Conditions of Sale or other applicable terms agreed to in writing. No use of any Renesas resources expands or otherwise alters any applicable warranties or warranty disclaimers for these products.

(Disclaimer Rev.1.01 Jan 2024)

Corporate Headquarters

TOYOSU FORESIA, 3-2-24 Toyosu,
Koto-ku, Tokyo 135-0061, Japan
www.renesas.com

Trademarks

Renesas and the Renesas logo are trademarks of Renesas Electronics Corporation. All trademarks and registered trademarks are the property of their respective owners.

Contact Information

For further information on a product, technology, the most up-to-date version of a document, or your nearest sales office, please visit www.renesas.com/contact-us/.