

DA1458x Reference Design

Design Name	da1458x_qfn40_prodb_va1
Supported chips	DA14580,DA14581,DA14583,DA14585(default),DA14586
Ref. Number	321-2-A1
Version	A01
Date	May , 02, 2017
Designer	PR KR

History Table		
Version	Date	Comments
A00	19 /Oct / 2016	Initial Schematic
A01	02 /May / 2017	1.R7 changed to 1Kohm 2.Xtall Y2 changed to TXC 9HT11-32.768KDZB-T (6pF)

Configuration note

NOTE box

Changes in this Version.



Label_Dialog_L6008

<Variant Name>

		Dialog Semiconductor N.E.O. Athinon- Patron 15 26441, Patra, Greece tel. (+30) 2610390940 fax. (+30) 2610390941
Title : da1458x_qfn40_prodb		
Doc. Nr.	Designer: PR	Rev:A
Date: Friday, May 05, 2017	Sheet: 0 of	1

—○ TP11 FIDUCIAL

—○ TP12 FIDUCIAL



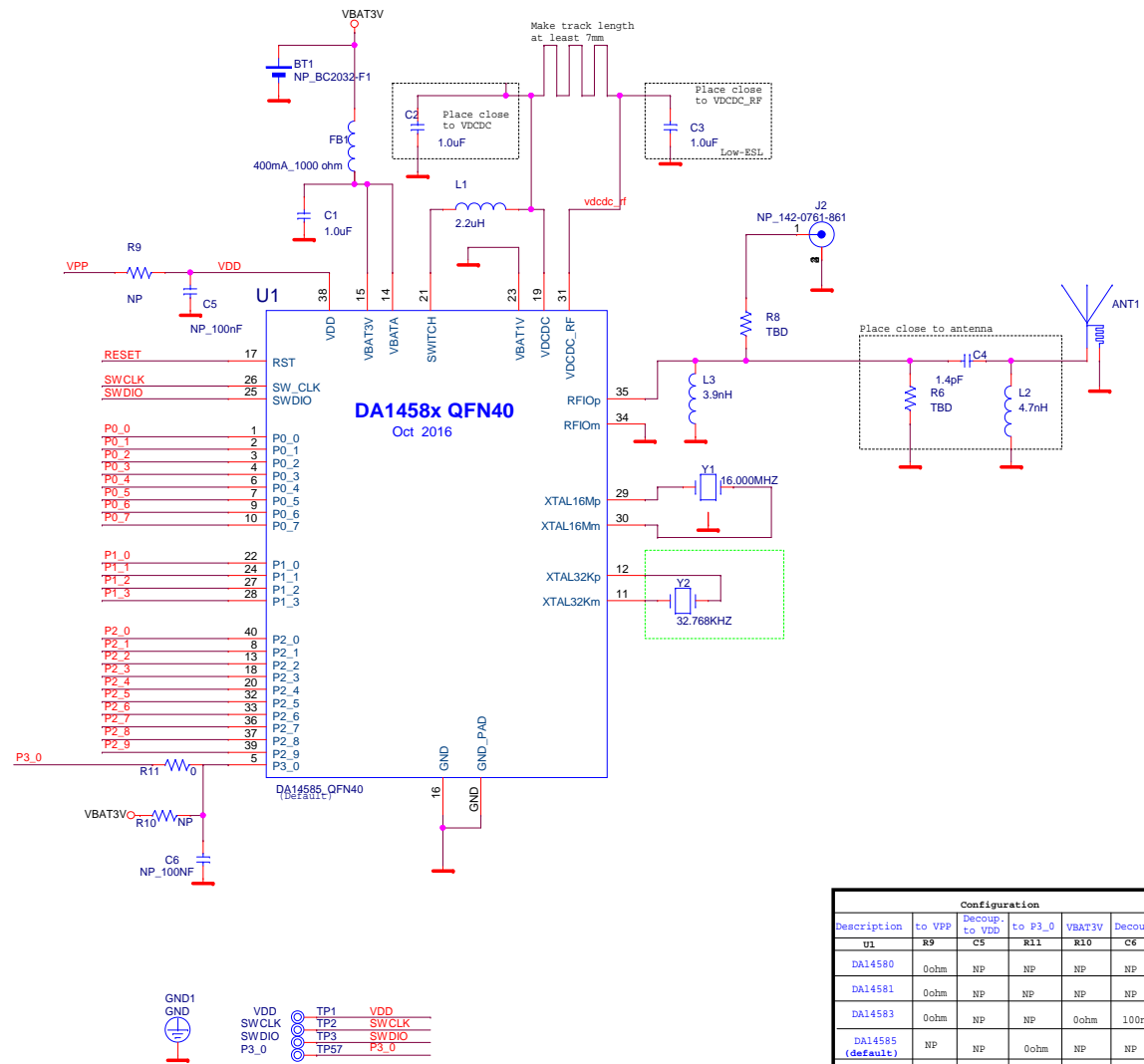
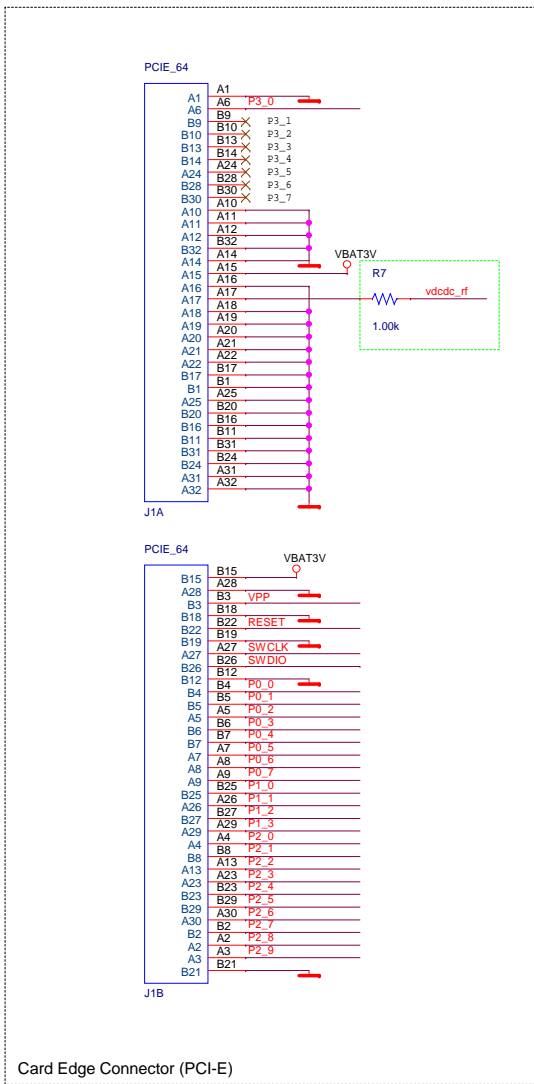

<Variant Name>

Dialog Semiconductor
N.E.O. Athinon - Patron 15
26441, Patra, Greece
tel. (+30) 2610390940
fax. (+30) 2610390941

Title: da1458x_qfn40_prodb
Doc. Nr. Designer: PR Rev: A
Date: Friday, May 05, 2017 Sheet: 1 of 1