

REV	DESCRIPTION	DATE	APPVD
A	PRODUCTION RELEASE	03-21-2014	MD

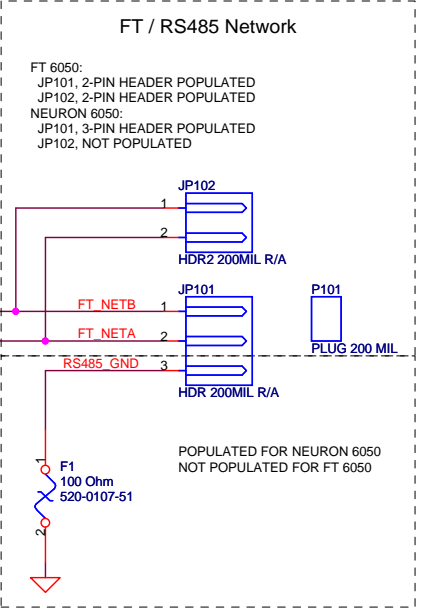

- ICT156 - 1 - IO8\_R1OUT
- ICT157 - 1 - IO4\_R2OUT
- ICT158 - 1 - IO1\_R3OUT
- ICT159 - 1 - IO0\_T2IN
- ICT160 - 1 - RSRX
- ICT161 - 1 - RSRTS
- ICT162 - 1 - RSHRDY
- ICT163 - 1 - RSTX
- ICT164 - 1 - RSCTS
- ICT165 - 1 - FORCEON
- ICT166 - 1 - PDF
- ICT168 - 1 - PD5
- ICT169 - 1 - PD6
- ICT178 - 1 - RS485\_GND

Title		SCHEMATIC, ECHELON SERIES 6000 EVB	
Doc. #	012-1460-51	Rev	A
Engineer	Jack Wilson	Modified:	Wednesday, July 02, 2014
Drawn By	JW / JTS / MD	Sheet	1 of 3

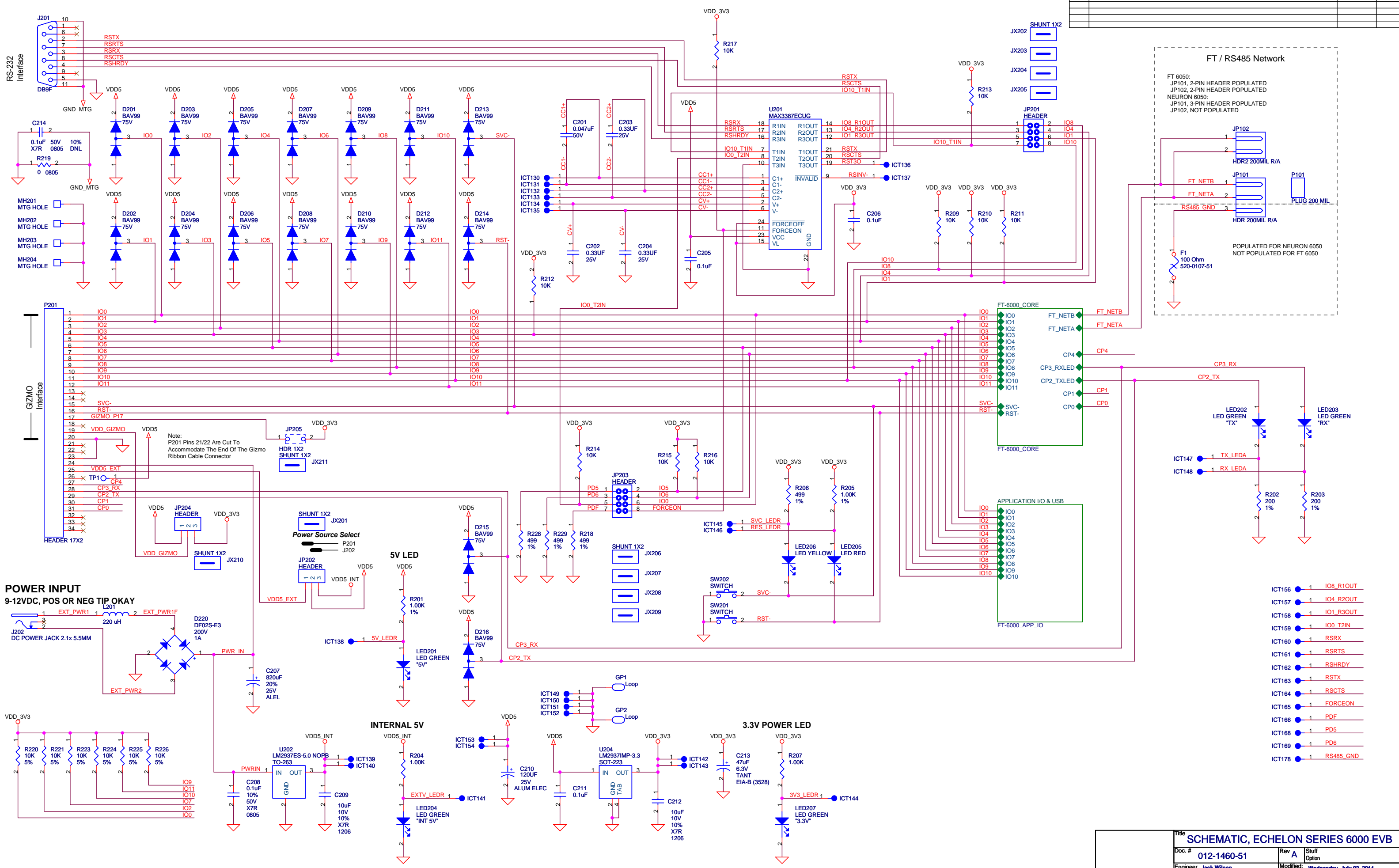
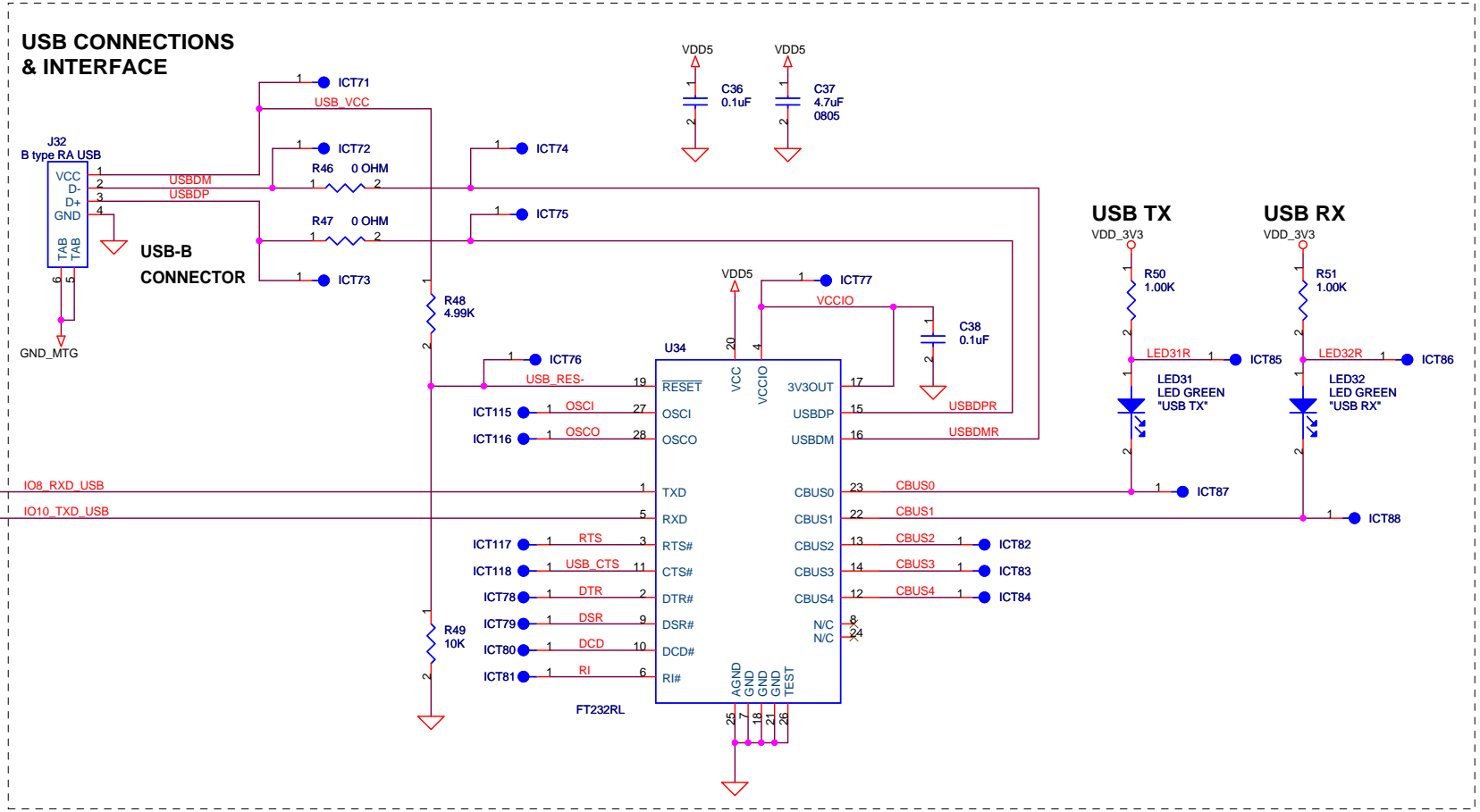
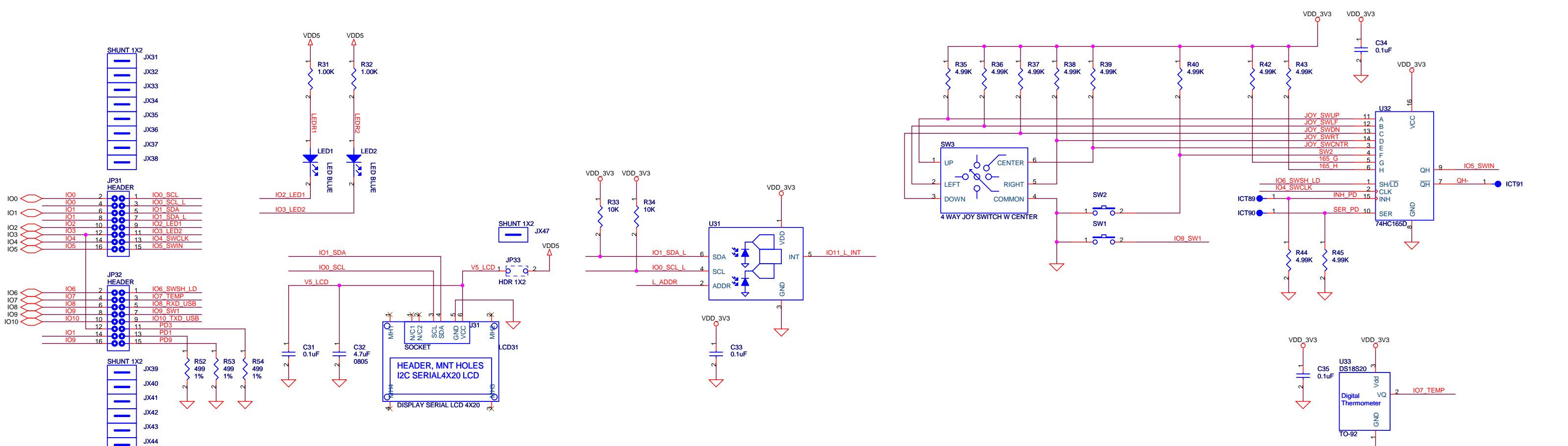

- ICT92 - 1 JOY\_SWUP
- ICT93 - 1 JOY\_SWLF
- ICT94 - 1 JOY\_SWDN
- ICT95 - 1 JOY\_SWRT
- ICT96 - 1 JOY\_SWCNR
- ICT97 - 1 SW2
- ICT98 - 1 LEDR1
- ICT99 - 1 LEDR2
- ICT100 - 1 IO0\_SCL
- ICT101 - 1 IO1\_SDA
- ICT102 - 1 IO2\_LED1
- ICT103 - 1 IO3\_LED2
- ICT104 - 1 IO4\_SWCLK
- ICT105 - 1 IO5\_SWIN
- ICT106 - 1 IO6\_SWSH\_LD
- ICT107 - 1 IO7\_TEMP
- ICT108 - 1 IO8\_RXD\_USB
- ICT109 - 1 IO9\_SW1
- ICT110 - 1 IO10\_TXD\_USB
- ICT111 - 1 IO1\_SDA\_L
- ICT112 - 1 IO0\_SCL\_L
- ICT113 - 1 IO11\_L\_INT
- ICT114 - 1 L\_ADDR
- ICT167 - 1 PD1
- ICT170 - 1 PD9
- ICT172 - 1 PD3

**On Board I/O & USB**

Title		<b>SCHEMATIC, ECHELON SERIES 6000 EVB</b>	
Doc. #	012-1460-51	Rev	A
Engineer	Jack Wilson	Option	Stuff
Modified:	Wednesday, July 02, 2014	Sheet	2 of 3
Drawn By	Jack Wilson/JTS		

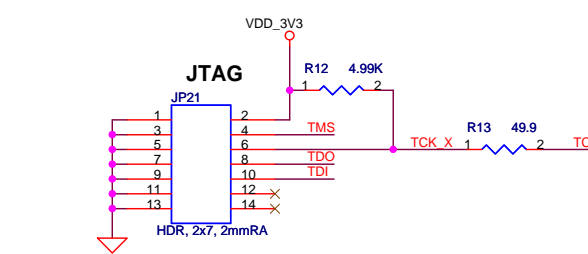
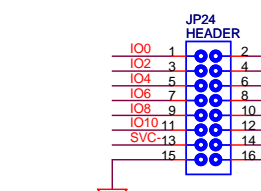
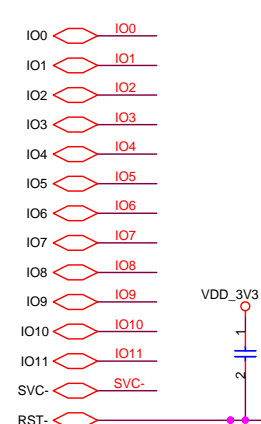
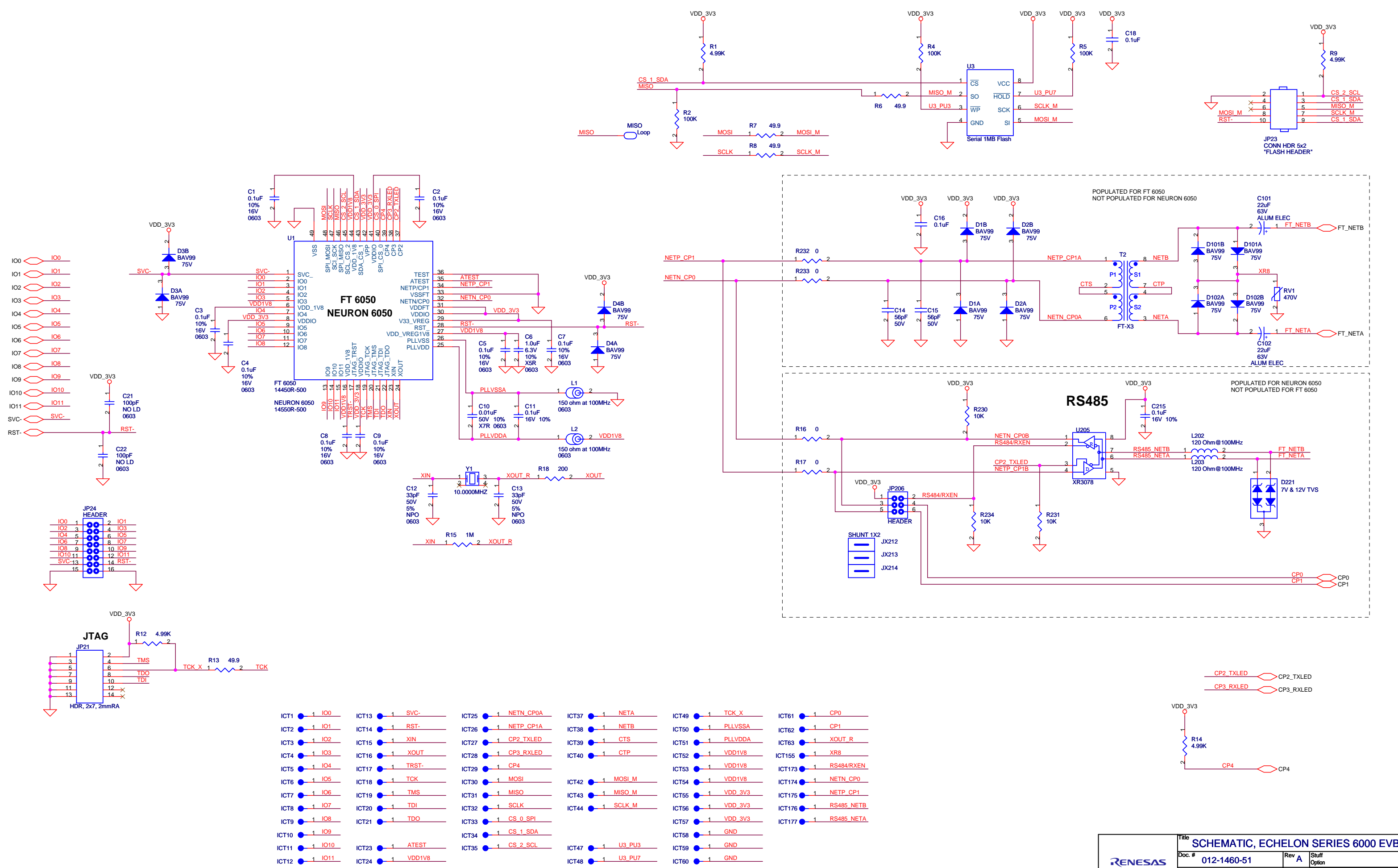

ICT1	1	IO0	ICT13	1	SVC-	ICT25	1	NETN_CP0A	ICT37	1	NETA	ICT49	1	TCK_X	ICT61	1	CP0
ICT2	1	IO1	ICT14	1	RST-	ICT26	1	NETP_CP1A	ICT38	1	NETB	ICT50	1	PLLVSSA	ICT62	1	CP1
ICT3	1	IO2	ICT15	1	XIN	ICT27	1	CP2_TXLED	ICT39	1	CTS	ICT51	1	PLLVDDA	ICT63	1	XOUT_R
ICT4	1	IO3	ICT16	1	XOUT	ICT28	1	CP3_RXLED	ICT40	1	CTP	ICT52	1	VDD1V8	ICT155	1	XR8
ICT5	1	IO4	ICT17	1	TRST-	ICT29	1	CP4	ICT42	1	MOSI	ICT53	1	VDD1V8	ICT173	1	RS484/RXEN
ICT6	1	IO5	ICT18	1	TCK	ICT30	1	MOSI	ICT43	1	MOSI_M	ICT54	1	VDD1V8	ICT174	1	NETN_CP0
ICT7	1	IO6	ICT19	1	TMS	ICT31	1	MISO	ICT44	1	SCLK_M	ICT55	1	VDD_3V3	ICT175	1	NETP_CP1
ICT8	1	IO7	ICT20	1	TDI	ICT32	1	SCLK	ICT47	1	U3_PU3	ICT56	1	VDD_3V3	ICT176	1	RS485_NETB
ICT9	1	IO8	ICT21	1	TDO	ICT33	1	CS_0_SPI	ICT48	1	U3_PU7	ICT57	1	VDD_3V3	ICT177	1	RS485_NETA
ICT10	1	IO9	ICT23	1	ATEST	ICT34	1	CS_1_SDA	ICT58	1	GND	ICT59	1	GND			
ICT11	1	IO10	ICT24	1	VDD1V8	ICT35	1	CS_2_SCL	ICT60	1	GND						
ICT12	1	IO11															