

HXR8204-DNG

Four-Channel 28Gbps TIA+PA Receiver

The HXR8204 is a four-channel trans-impedance limiting amplifier array with post amplifiers. The device is a member of the Renesas family of Optical Receiver Transmitter Array (ORTA) products. When combined with a PIN photo-detector array, the user can design a high-bandwidth optical receiver for Ethernet, InfiniBand, and Industrial applications.

The HXR8204 operates in a 3.3V supply and with high BW post amplifier and a versatile CML output. Built-in equalization offers superior signal output, and it offers various enhanced analog mode and I²C digital interface with more controls and monitoring functions.

Applications

- 100G Ethernet SR4 modules and AOC
- Industrial optical interconnect applications and optical HDMI cables
- InfiniBand EDR transceivers and AOC
- Proprietary multi-channel optical modules

Features

- 50 μ App receiver sensitivity for 10-12 BER at 28Gbps
- Better than 2.4mAPP overload
- Power consumption as low as 84mW per channel
- Adjustable output swing and pre-emphasis
- Programmable signal detect threshold
- Independent RSSI per channel
- Optimized for isolated and common cathode photo-detector arrays from multiple vendors
- Control lines accessible on both sides of chip
- 2-wire interface control and analog control modes

Ordering Information

Part Number	Temp. Range	Die Dimension
HXR8204-DNG	-40°C to +105°C	2.025 x 1.65mm
HXR8204-EVB	Room temp	Evaluation Board

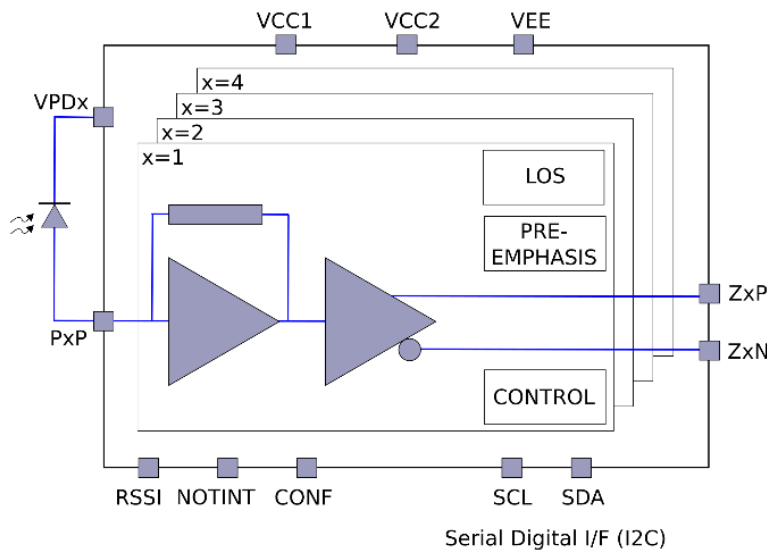

Figure 1. Block Diagram

IMPORTANT NOTICE AND DISCLAIMER

RENESAS ELECTRONICS CORPORATION AND ITS SUBSIDIARIES (“RENESAS”) PROVIDES TECHNICAL SPECIFICATIONS AND RELIABILITY DATA (INCLUDING DATASHEETS), DESIGN RESOURCES (INCLUDING REFERENCE DESIGNS), APPLICATION OR OTHER DESIGN ADVICE, WEB TOOLS, SAFETY INFORMATION, AND OTHER RESOURCES “AS IS” AND WITH ALL FAULTS, AND DISCLAIMS ALL WARRANTIES, EXPRESS OR IMPLIED, INCLUDING, WITHOUT LIMITATION, ANY IMPLIED WARRANTIES OF MERCHANTABILITY, FITNESS FOR A PARTICULAR PURPOSE, OR NON-INFRINGEMENT OF THIRD-PARTY INTELLECTUAL PROPERTY RIGHTS.

These resources are intended for developers who are designing with Renesas products. You are solely responsible for (1) selecting the appropriate products for your application, (2) designing, validating, and testing your application, and (3) ensuring your application meets applicable standards, and any other safety, security, or other requirements. These resources are subject to change without notice. Renesas grants you permission to use these resources only to develop an application that uses Renesas products. Other reproduction or use of these resources is strictly prohibited. No license is granted to any other Renesas intellectual property or to any third-party intellectual property. Renesas disclaims responsibility for, and you will fully indemnify Renesas and its representatives against, any claims, damages, costs, losses, or liabilities arising from your use of these resources. Renesas' products are provided only subject to Renesas' Terms and Conditions of Sale or other applicable terms agreed to in writing. No use of any Renesas resources expands or otherwise alters any applicable warranties or warranty disclaimers for these products.

(Disclaimer Rev.1.01)

Corporate Headquarters

TOYOSU FORESIA, 3-2-24 Toyosu,
Koto-ku, Tokyo 135-0061, Japan
www.renesas.com

Trademarks

Renesas and the Renesas logo are trademarks of Renesas Electronics Corporation. All trademarks and registered trademarks are the property of their respective owners.

Contact Information

For further information on a product, technology, the most up-to-date version of a document, or your nearest sales office, please visit www.renesas.com/contact-us/.