

Brief Description

The ZLED7010, one of our ZLED Family of LED control ICs, is an inductive step-down converter that is optimal for driving a single LED or multiple LEDs (connected in series) from a voltage source greater than the voltage rating of the LED. The ZLED7010 operates in continuous mode. Capable of operating efficiently with voltage supplies ranging from 6 VDC to 40 VDC, it is ideal for low-voltage lighting applications. The ZLED7010 minimizes current consumption by remaining in a low-current standby mode (output is off) until a voltage of $\geq 0.3V$ is applied to the ADJ_I pin.

In operating mode, the ZLED7010 can source LEDs with an output current of $\leq 750mA$ (≤ 30 watts of output power*) that is externally adjustable. The ZLED7010's integrated output switch and high-side current sensing circuit use an external resistor to adjust the average output current. LED control is achieved via an external control signal at the ZLED7010's ADJ_I pin, implemented as a pulse-width modulation (PWM) waveform for a gated output current or a DC voltage for continuous current.

The ZLED7010 provides a temperature compensation function for maintaining stable and reliable LED operation. LED over-temperature conditions are detected via a negative temperature coefficient (NTC) thermistor mounted close to the LEDs. If an over-temperature condition occurs, the NTC value reaches the value of a threshold resistor and the IC reduces LED current automatically. After the circuit recovers to a safe temperature, current returns to the set value.

ADJ_O outputs and ADJ_I inputs of consecutive ICs can be interconnected as a driver chain deploying the temperature compensation information of the predecessor. This reduces the part count because only the first stage of the series requires an NTC.

Features

- Capable of 95% efficiency*
- Operates in continuous mode with a wide input range from 6 VDC to 40 VDC
- Integrated 40V power switch
- One-pin on/off or brightness control via DC voltage or PWM control signal
- Switching frequency: $\leq 1MHz$
- Dimming rate: 1200:1 (typical)
- Output current accuracy: 5% (typical)
- Built-in temperature compensation and open-circuit protection for LEDs
- Thermal shutdown protection for the ZLED7010
- Very few external components needed for operation
- Broad range of applications: outputs up to $\leq 750mA$
- SOP-8 package

Application Examples

- Illuminated LED signs and other displays
- LED traffic and street lighting (low-voltage)
- Architectural LED lighting, including low-voltage applications for buildings
- Halogen replacement LEDs (low-voltage)
- LED flood-lighting
- LED backlighting
- General purpose exterior and interior LED lighting, including applications requiring low-voltage
- General purpose low-voltage industrial applications

ZLED7010 Application Circuit

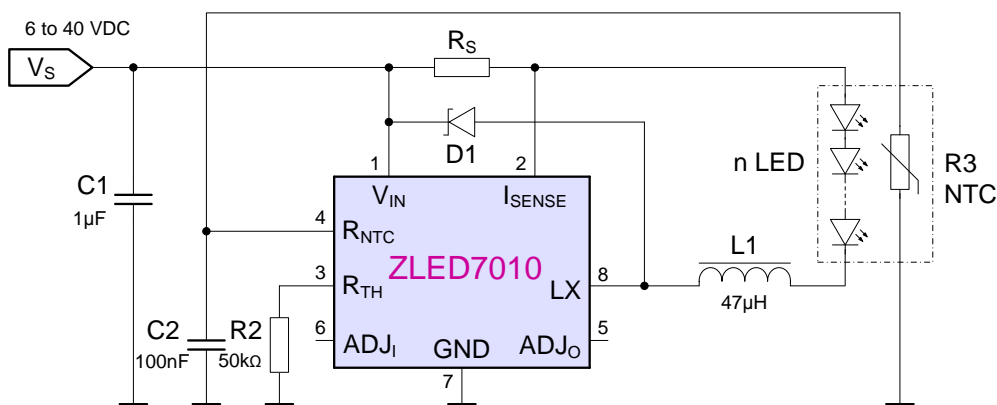

* See section 2.3 and 1.4 for details

SOP-8 Package Dimensions and Pin Assignments

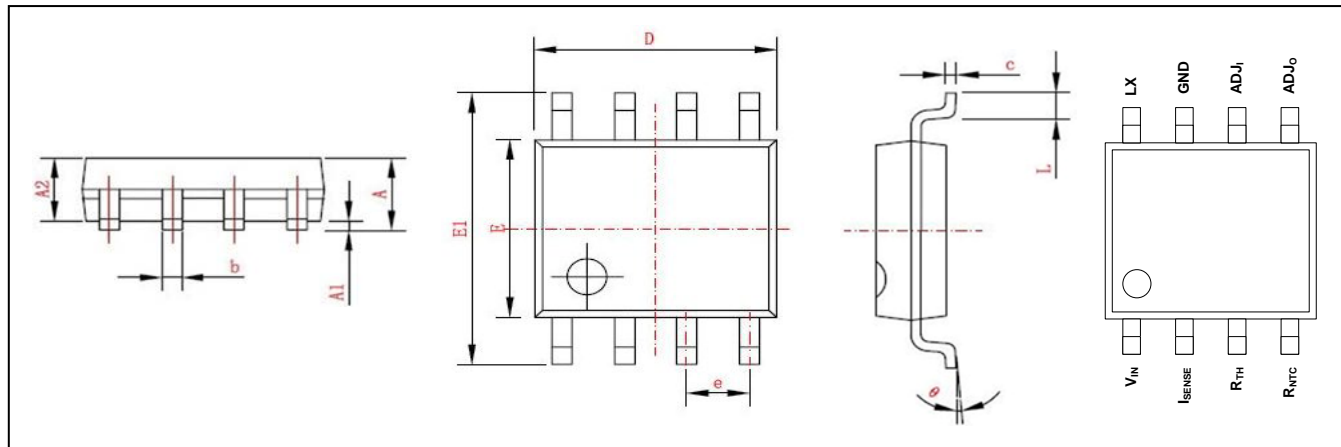

Symbol	Dimension (mm)		Symbol	Dimension (mm, except θ)	
	Min	Max		Min	Max
A	1.350	1.750	E	3.800	4.000
A1	0.100	0.250	E1	5.800	6.240
A2	1.450 Typical		e	1.270 Typical	
b	0.350	0.490	L	0.400	1.270
c	0.178	0.250	θ	0°	8°
D	4.800	5.000			

Ordering Information

Product Sales Code	Description	Package
ZLED7010ZI1R	ZLED7010 – 40V LED Driver with Temperature Compensation	SOP8 (Tape & Reel)
ZLED7010KIT-D1	ZLED7010 Demo Board with LED on Cool Body 12VAC/VDC	Kit
ZLED-PCB1	Test PCB with one 3W white HB-LED, cascadable to 1 multiple LED string	Printed Circuit Board
ZLED-PCB2	10 unpopulated test PCBs for modular LED string with footprints of 9 common HB-LED types	Printed Circuit Board

IMPORTANT NOTICE AND DISCLAIMER

RENESAS ELECTRONICS CORPORATION AND ITS SUBSIDIARIES (“RENESAS”) PROVIDES TECHNICAL SPECIFICATIONS AND RELIABILITY DATA (INCLUDING DATASHEETS), DESIGN RESOURCES (INCLUDING REFERENCE DESIGNS), APPLICATION OR OTHER DESIGN ADVICE, WEB TOOLS, SAFETY INFORMATION, AND OTHER RESOURCES “AS IS” AND WITH ALL FAULTS, AND DISCLAIMS ALL WARRANTIES, EXPRESS OR IMPLIED, INCLUDING, WITHOUT LIMITATION, ANY IMPLIED WARRANTIES OF MERCHANTABILITY, FITNESS FOR A PARTICULAR PURPOSE, OR NON-INFRINGEMENT OF THIRD-PARTY INTELLECTUAL PROPERTY RIGHTS.

These resources are intended for developers who are designing with Renesas products. You are solely responsible for (1) selecting the appropriate products for your application, (2) designing, validating, and testing your application, and (3) ensuring your application meets applicable standards, and any other safety, security, or other requirements. These resources are subject to change without notice. Renesas grants you permission to use these resources only to develop an application that uses Renesas products. Other reproduction or use of these resources is strictly prohibited. No license is granted to any other Renesas intellectual property or to any third-party intellectual property. Renesas disclaims responsibility for, and you will fully indemnify Renesas and its representatives against, any claims, damages, costs, losses, or liabilities arising from your use of these resources. Renesas' products are provided only subject to Renesas' Terms and Conditions of Sale or other applicable terms agreed to in writing. No use of any Renesas resources expands or otherwise alters any applicable warranties or warranty disclaimers for these products.

(Disclaimer Rev.1.01 Jan 2024)

Corporate Headquarters

TOYOSU FORESIA, 3-2-24 Toyosu,
Koto-ku, Tokyo 135-0061, Japan
www.renesas.com

Trademarks

Renesas and the Renesas logo are trademarks of Renesas Electronics Corporation. All trademarks and registered trademarks are the property of their respective owners.

Contact Information

For further information on a product, technology, the most up-to-date version of a document, or your nearest sales office, please visit www.renesas.com/contact-us/.