

How a new architecture for NFC transmitters brings fast NFC wireless charging to the consumer device market

By Alessandro Goitre

Product Marketing Director, Panthronics AG

www.panthronics.com

The technology of wireless charging has the wind in its sails. The trend to embed wireless charging capability into consumer devices has been led by the Wireless Power Consortium's (WPC) Qi charging standard, which is the most widely adopted technology for the wireless charging of smartphones. The momentum is accelerating as more and more charging locations, such as the centre console in new cars, home appliances or shops offer convenient wireless charging for compatible devices.

As a result, consumer acceptance and knowledge are growing, leading manufacturers of other types of devices beyond the mobile phone to explore the potential for wireless charging.

Manufacturers of consumer devices are ready to evaluate alternative technologies for implementing wireless charging in a small form factor. The great advantages of replacing a wired charger connection with wireless charging are:

- Increased reliability – every wired connection is a potential point of failure. The miniature connectors are particularly prone to damage from mechanical stresses such as bending.
- Increased design freedom – consumer devices such as wearables have a limited surface area. The designer can optimise the shape of the device and the use of its surface when they do not have to accommodate a connector.
- Easier to achieve a high Ingress Protection (IP) rating - by eliminating mechanical connections, manufacturers can close a point of entry for contaminants such as water, sweat and dust.

For various reasons, the Qi technology is poorly suited to the charging of very small or wearable devices such as activity-tracking wristbands, wireless earphones, or smart glasses. One seemingly ideal alternative is NFC, the technology behind contactless payments and ticketing, since another of the inherent features of NFC, alongside data communication, is energy harvesting – the ability of a receiver (listener) to draw energy from a reader's (poller's) transmitted signal.

This means that any NFC-enabled device that has energy harvesting capability can be charged wirelessly without the need for an additional antenna and other components. In addition, NFC wireless charging, unlike other charging technologies, does not require perfect alignment of the charger's and receiver's antennas. An NFC charger works at high efficiency on the charger side even when the two antennas are misaligned by as much as half of the antenna size.

Yet despite the almost universal provision of NFC functionality in smartphones – which could operate as a charging station for other, smaller devices – NFC charging has been implemented in

only a handful of small devices: this is because the power transmitted by the poller limits the scope to charge devices which have a larger battery capacity or smaller NFC antenna.

Now, however, a breakthrough in NFC system design promises to double the power that can be supplied via an NFC connection, while also providing a reduction in component count, bill-of-materials cost and system size. This article describes how this fast-charging NFC capability could affect the design of new consumer products.

NFC, a viable complement to Qi wireless charging

Qi wireless charging has proven to be a successful technology for devices such as smartphones which have a large battery – typically 3,000mAh or more – and which therefore require the >5W power capability that Qi offers. Indeed, the WPC is actively promoting efforts to extend the power rating of Qi to enable wireless charging of even larger devices such as tablets and laptop computers.

But the elements of Qi technology which make it suitable for use in these high-power applications – such as its requirement for a large antenna in the receiver – make it unsuitable for use in smaller products such as wearable devices. When a charged device needs a 1W supply rather than 15W, a Qi system is generally too bulky and too expensive. It also provides a limited data communication capability.

By contrast, NFC is the ideal technology to charge wirelessly devices where flexibility is a key factor:

- There is a huge installed base of billions of NFC-enabled devices in the field, so the technology is familiar both to consumers and to design engineers. Most smartphones could act as a charger for NFC devices.
- NFC technology supports bi-directional communication. Depending on the communication protocol used and the capability of the remote device, a communication speed of up to 848kbits/s is supported by NFC devices. If NFC is used as the technology for a device's communications anyway, wireless charging can enhance the product's feature set and consumer appeal at no extra bill-of-materials cost.
- NFC allows for misalignment of the transmitter's and receiver's antennas without impairing the efficiency of power transmission.
- NFC allows for a compact implementation with a smaller antenna in both the poller and listener devices.

NFC implementation is not complicated: charging capability is built into the standard NFC Forum protocols. In NFC's Wireless Charging mode, the field strength of the RF field can be increased to maximise the power transfer capability between two compliant devices.

Reason for slow adoption of NFC for wireless charging

NFC is little used for wireless charging today, mainly because NFC transmitters are based on a conventional architecture which typically have the power output at the transmitter's antenna up to 1.5W. In this architecture, the NFC transmitter generates a square-wave output signal (see Figure 1).

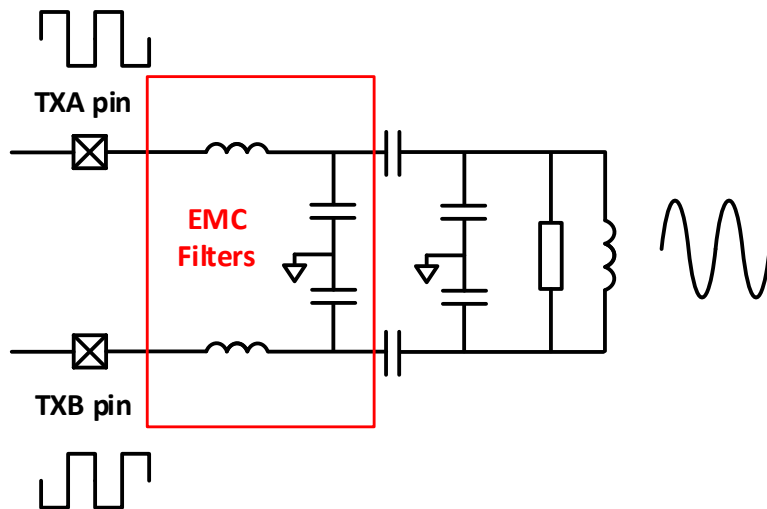

Fig. 1: the conventional architecture of NFC transmitters for wireless chargers. (Image credit: Panthronics)

This square-wave architecture is an attractive choice for NFC component manufacturers because it is easy to implement in silicon. But the square wave output has to be shaped as a sine wave for transmission via the antenna to avoid electromagnetic emissions exceeding the limits: this calls for an electromagnetic compatibility (EMC) filter made up of multiple external components.

In NFC charging, this has two important drawbacks:

- High power losses in the poller's EMC filter inductors reduce the power output, and therefore the input power at the listener.
- The higher matching impedance in order to operate an IC within the specification.
- Complex matching topology is typically very sensitive to coupling factor variation, which could lead to a lower performance with antenna misplacement.

In practice, this means that the conventional NFC transmitters used in today's wireless charging devices are typically leading to a 500mW power transfer on the listener condemning wearable devices to suffer from long charging durations.

Fortunately, there is another way – and its appeal is the result of the adoption of a dramatically different architecture in the transmitter and receiver.

All-new architecture features sine-wave output

The new architecture – the result of a patented silicon implementation developed by Panthronics – produces a sine-wave output at the transmitter pin (see Figure 2). As a consequence, the NFC circuit requires no lossy EMC filter, and thus enables a direct-to-antenna ('DiRAC') connection from the transmitter pin.

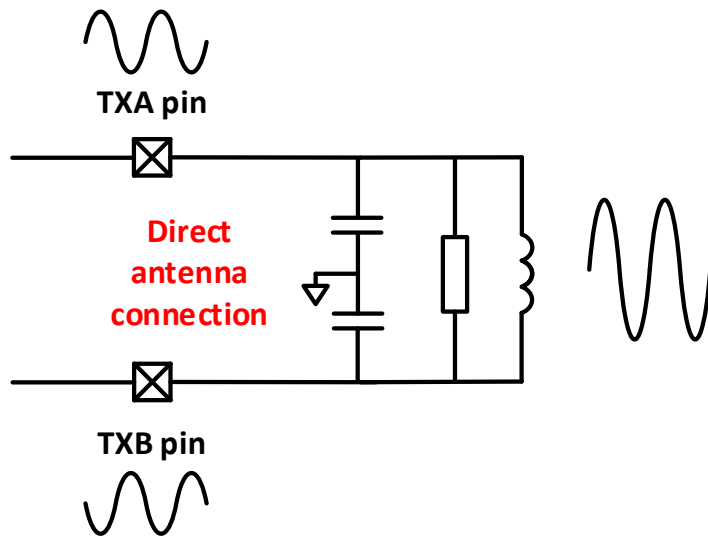

Fig. 2: the Panthronics sine-wave architecture implemented in its PTX100W NFC transmitter requires no EMC filter and few antenna-matching components. (Image credit: Panthronics)

The key advantages of this architecture are the mirror image of the drawbacks of conventional NFC controllers:

- Losses are reduced because the EMC filter and most matching components are eliminated.
- Because the sine-wave circuit eliminates various wide-tolerance capacitors and inductors, a much lower-impedance antenna matching circuit can be used, increasing the transmitter's output power.
- Less components also simplify the system matching and solve the variation in production introduced by component tolerance.
- Homogeneous harvesting power over volume
- Constantly optimized system matching over displacement

Operating from a 5V supply, a Panthronics solution based on its PTX100W NFC charger can supply up to 1W power on the listener. One of the main reasons why the Panthronics architecture can sustain more power is the lower antenna matching impedance which can be achieved in a circuit with no EMC filter. An application based on the PTX100W can be designed with an antenna matching impedance of less than 5Ω, while with an EMC filter the impedance would be at least twice as high.

Importantly, the elimination of the EMC filter and other external components also produces a board area saving. This reduces the cost, size and complexity of the charger board – a valuable benefit for makers of wearable devices.

The charging capability of PTX100W are demonstrated in the below application examples.

1- Example of Smartwatch integration

The poller board is integrating the PTX100W. Poller and Listener antenna dimensions are corresponding to a typical integration into a smartwatch or fitness tracker.

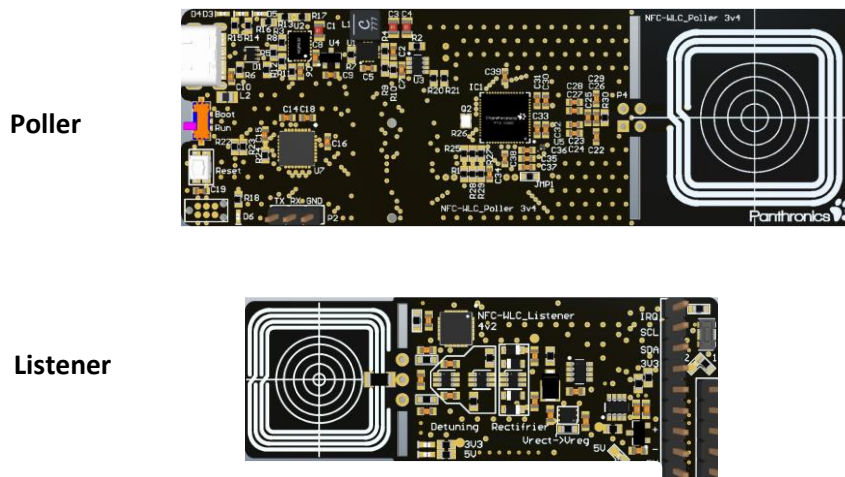

Fig. 3: Poller and Listener wireless charging boards used for WLC system demonstration (Image credit: Panthronics)

Under this condition the PTX100W is capable of delivering up to 1W to the listener battery, as measured by the power sensor on the listener board.

Moreover, as described in the below graph, also considering a misplacement between the poller and listener antennas, the power transferred is not degrading much over a volume.

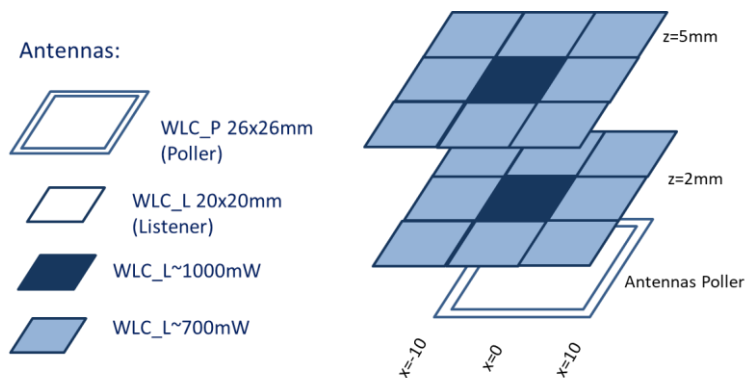

Fig. 4: Poller and Listener performances over volume and antenna misplacement (Image credit: Panthronics)

2- Example of earbud integration

In this application the antennas dimensions are much more limited affecting the overall power transfer. Using the PTX100W as a poller the power received by the earbud battery is described in the below graph. Even with a distance up to 5mm between the 2 antennas, the power transferred to the Earbuds antenna is still above the max power used to charge typical earbuds batteries.

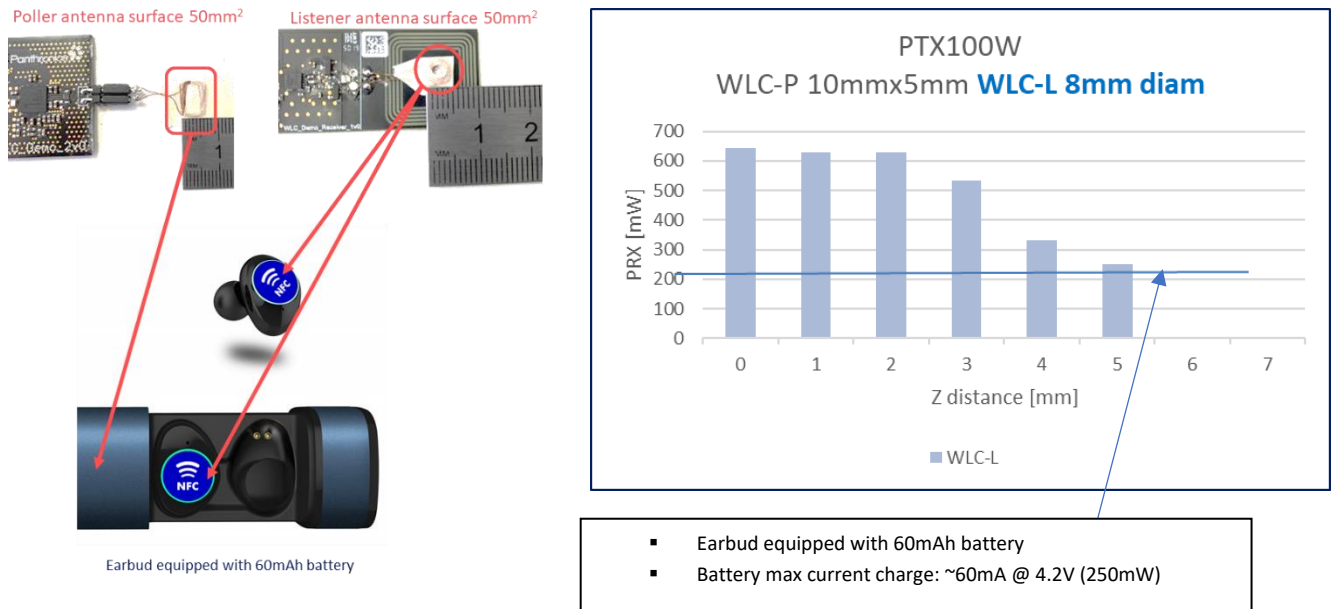

Fig. 5: Poller and Listener antenna integration in earbuds application (Image credit: Panthronics)

Increased transmitter output enables fast charging via NFC

By introducing the all-new PTX100W NFC charging controller, Panthronics is providing a new solution which offers superior power performance by virtue of its innovative sine-wave architecture (see Figure 3). While manufacturers of consumer devices have been slow to adopt NFC wireless charging to date because of the long time required to fully charge even a small battery, the introduction of the PTX100W overcomes the problem, providing an NFC wireless charging solution capable of delivering 1W power on the listener output and therefore shorten the charging durations.



Fig. 6: the PTX100W provides a compact solution for NFC charging in small electronics devices. (Image credit: Panthronics)