Power GreenPAK™ with Load Switches

Author: Irena Zhuravchak, Technical Documentation Applications Engineer, A&C/CMSD

Abstract

Load switches are one of the most important components in modern electronic devices, enabling efficient power management and enhancing system performance and reliability. They address key market challenges, such as energy saving, component protection, soft start, power distribution, and promote compactness and integration. Applications span across smartphones, tablets, laptops, consumer electronics, portable devices, industrial and automotive systems, and IoT devices, highlighting the diverse requirements for low power consumption, small size, high integration, reliability, safety features, wide voltage range support, easy integration, and fast response. Renesas Power GreenPAK™ family devices, incorporating load switches, provide exceptional flexibility and ease of configuration through the GreenPAK platform. These devices support high-drive current power switches up to 2 A, with single and dual switch options, effortlessly controlled via the GreenPAK Designer intuitive interface. The GreenPAK platform's configurable macrocells and integrated power solutions offer a compact, efficient, and rapid approach to modern power management needs, ensuring robust and reliable operation across a wide range of applications.

Contents

Abstract	1
1. Introduction	2
2. Customizing Power Systems with Power GreenPAK	3
3. Benefits of GreenPAK with Load Switches.....	3
4. Power GreenPAK with Load Switches Feature Sets.....	4
5. Example of Use: Overcurrent Protection Device on SLG46116 with Load Switch	5
6. Conclusion	6
7. Revision History	7

1. Introduction

Load switches are electronic components used to control the power supply to various parts of a circuit. They enable or disable power to a specific load, ensuring efficient power management and improving overall system performance and reliability.

Main market challenges for chips with load switches are listed below:

- Energy saving: optimizing power consumption by turning off inactive components or subsystems, which helps to extend the battery life of devices.
- Component protection: protection against overvoltage, overcurrent, short circuits, and overheating.
- Soft start: reducing inrush currents to prevent damage to components at power-up.
- Power distribution: controlling the power supply to different parts of the device to optimize system performance.
- Promote compactness and integration: reducing the size and number of components on a printed circuit board (PCB) by using integrated solutions.

Today, there is a wide range of products that use chips with load switches. Let's start with smartphones and tablets, which require these components to control the power of modules, such as the display, radio modules, cameras, and sensors. Laptops and ultrabooks also need load switches for efficient power management of CPU, GPU, drives, and other components. Load switches are also required in consumer electronics, such as TVs, audio devices, game consoles, and cameras, to optimize power consumption. Portable devices, such as smartwatches, fitness trackers, headphones, and other gadgets depend on optimal power management for long-lasting operation and therefore require load switches as well. In addition, it is worth mentioning industrial and automotive systems: controllers in machines, robotics, industrial sensors, and drives, where reliability and energy efficiency are crucial. And finally, load switches are useful even in the Internet of Things (IoT) industry, such as smart home devices, sensors, and controllers that require energy saving for long battery life.

As a result of the fact that load switches cover such a wide range of applications, there are many requirements for the chips that include them during the development process of certain products:

- Low power consumption: particularly important for portable devices, where minimizing power consumption helps to extend battery life.
- Small size and high integration: compact size and high level of integration that reduce PCB footprint.
- Reliability and durability: high reliability for long-term use without failure, especially in critical applications, such as automotive and industrial systems.
- Safety features: built-in overload, short circuit, overheating, and overvoltage protection mechanisms.
- Support for a wide voltage range: support of various input and output voltage levels for versatile use.
- Easy integration: easy to connect to mainstream control circuits, such as microcontrollers or processors.
- Fast response: fast switching capability to ensure efficient real-time system operation.

ICs with load switches are essential components in modern electronic devices, providing efficient power management, protection, and reliability of systems. And when it comes to efficiency and reliability, Renesas does not stand aside. Renesas Power GreenPAK family devices that include load switches offer a high level of flexibility that comes from connecting and configuring the resources of GreenPAK, while controlling high-drive current power switches. Load switches are easy to control. It is possible to connect IO pins, Look Up Tables (LUTs), Counter/Delay macrocells, or other GreenPAK macrocells as the source signals for switching load signals on and off.

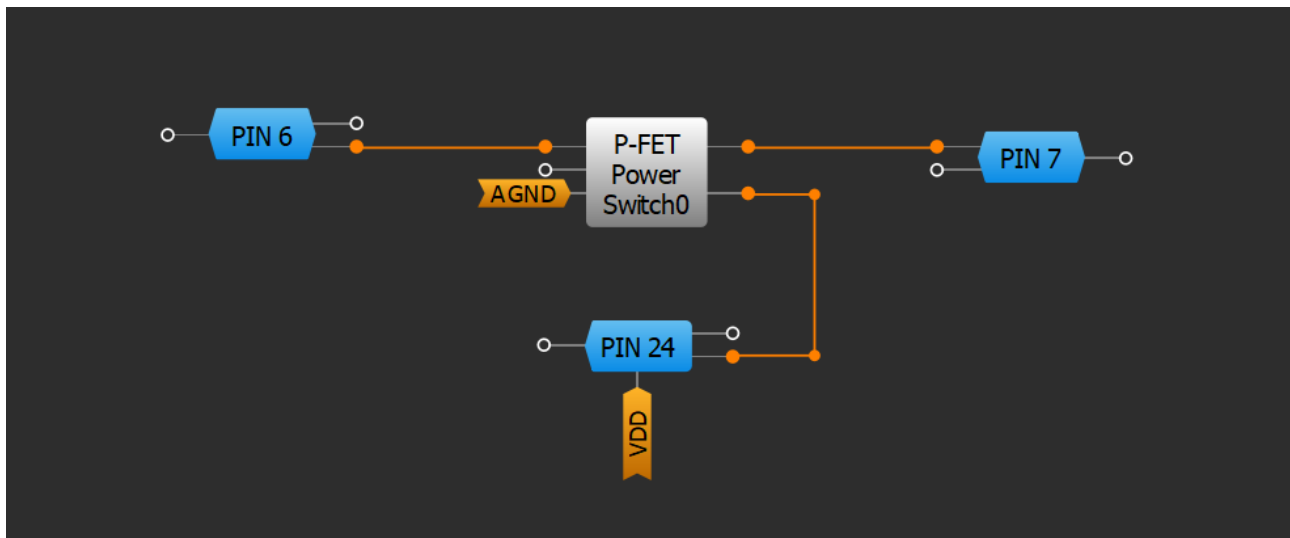

Figure 1. Power GreenPAK with Load Switch Example

2. Customizing Power Systems with Power GreenPAK

The Power GreenPAK platform offers a customizable solution for power systems, integrating advanced power management and control within the user-friendly GreenPAK framework. Renesas Power GreenPAK is particularly suitable for efficient power management through low dropout (LDO) and DC-DC converters, leveraging the proven success of the GreenPAK programmable ASIC platform. This platform ensures robust power control via load switches that provide essential power protection, distribution, and sequencing. Additionally, the Power GreenPAK system is easily configurable to meet specific requirements, enabling the development of customized, integrated power solutions that are compact, efficient, and rapidly deployable to the market.

3. Benefits of GreenPAK with Load Switches

Flexibility and Efficiency of GreenPAK Configurable Macrocells

Flexibility of the GreenPAK platform is exemplified by its array of configurable macrocells. These include analog comparators (SLG46xxx), combination function macrocells, asynchronous state machines (ASM)/power sequencers, and I²C slave protocol interfaces. Additionally, the platform incorporates essential logic elements, such as LUTs, DFFs, and delay blocks. This versatile configurability allows for creation of highly customized power solutions tailored for specific application requirements.

Power Supply Management and Efficient Power Consumption

Power GreenPAK excels in power supply management and efficient power consumption. It features load switches capable of handling up to 2 A, with options for both single and dual power switches. The small size of the platform is further enhanced by its packaging options, including WLCSP and TQFN with a 0.4 pitch. These compact packages make Power GreenPAK an ideal choice for applications where space is at a premium, ensuring both efficiency and effectiveness in power management solutions.

4. Power GreenPAK with Load Switches Feature Sets

Renesas offers a wide range of Power GreenPAK products with load switches. Below is a comparison table with the representatives of this product line and their features.

	SLG46116/7	SLG46127	SLG46517	SLG46867M	SLG51000	SLG51001	SLG51002	SLG51003
Power Parameters								
# of Load Switches	1	2	2	2	2	1	5	1
Load Switch Type (PMOS / NMOS)	1 x PMOS	2 x PMOS	2 x PMOS	2 x PMOS	2 x NMOS	2 x NMOS	3 x NMOS, 2 x PMOS	1 x NMOS
Max Iout	1.25 A	2 A	2 A	2 A	0.8 A	1 A	1.3 A	0.8 A
RDS _{ON}	28.5 mOhm	44 mOhm	44 mOhm	44 mOhm	40 mOhm	40 mOhm	40 mOhm	40 mOhm
Programmable Current Limit	-	-	-	-	Yes	Yes	Yes	Yes
Slew Rate	Fixed	-	-	-	Yes	Yes	Yes	Yes
# of LDOs	-	-	-	-	7	6	8	3
Protection Features	ESD, Read Lock	ESD, Read Lock	ESD, Read Lock	ESD, Read Lock	ESD, OCP, OTP	ESD, OCP, OTP	ESD, OCP, OTP	ESD, OCP, OTP
Combinatorial Logic								
Analog Comparators	2	2	4	4	-	-	-	-
Max LUT / DFF	10 / 4	10 / 4	17 / 8	23 / 21	12 / -	12 / -	8 / 8	8 / 8
Pipe Delay	8-stage	8-stage	16-stage	16-stage	-	-	-	-
Internal Oscillator (Hz)	25 k / 2 M	25 k / 2 M	25 k / 2 M / 25 M	2 k / 2 M / 25 M	8 M	8 M	8 M	8 M
Max. Counters/Delays	4	4	7	8	-	-	- / 4	- / 4
Combination Function Macrocells	6	6	17	15	-	-	7	7
State Machine	-	-	8-state ASM	-	Power Sequencer	Power Sequencer	Power Sequencer	-
General Parameters								
# of Pins/GPIOs	14 / 7	16 / 6	28 / 16	20 / 12	20 / 6	16 / 4	25 / 6	14 / 5
Operating Voltage	1.8 V - 5.0 V	1.8 V - 5.0 V	1.8 V - 5.0 V	2.3 V - 5.5 V	2.8 V - 5 V	2.8 V - 5 V	2.8 V - 5 V	2.8 V - 5 V
Communication Interface Type	-	-	I ² C	I ² C	I ² C	I ² C	I ² C	I ² C
Communication Interface Voltage	-	-	1.2 V - 5 V	1.2 V - 5 V	1.2 V - 1.8 V	1.2 V - 1.8 V	1.2 V - 1.8 V	1.2 V - 5 V
GPIO Voltage	1.2 V - 5 V	1.2 V - 5 V	1.2 V - 5 V	1.2 V - 5 V	1.2 V - 1.8 V	1.2 V - 1.8 V	1.2 V - 5 V	1.2 V - 5 V
Package Type	TQFN	TQFN	TQFN	TQFN	WLCSP	WLCSP	WLCSP	TQFN
Package Size (mm)	1.6 x 2.5	1.6 x 2.0	2.0 x 3.0	1.6 x 3.0	1.675 x 2.075	1.675 x 1.675	1.992 x 1.992	2.0 x 2.2
Operating temperature	-40°C to 85°C	-40°C to 85°C	-40°C to 85°C	-40°C to 85°C	-40°C to 85°C	-40°C to 85°C	-40°C to 85°C	-40°C to 85°C

5. Example of Use: Overcurrent Protection Device on SLG46116 with Load Switch

Example design in this section shows how to create an overcurrent protection device based on the SLG46116. Overcurrent protection is the protection against excessive currents or currents beyond the acceptable current rating of the device. To protect downstream loads, the point of overcurrent protection should occur at the FET switch.

The SLG46116 includes a P-FET Power Switch designed for load-switching applications. The P-FET Power Switch can be controlled internally via the ON digital input of the P-FET Power Switch component in the GreenPAK Designer, allowing the user to generate integrated mixed-signal control circuits.

The P-FET Power Switch contains 28.5 mΩ RDS_{ON}, 1.25 A P-channel MOSFET with fixed slew rate control. The device has a built-in soft start, which controls the output rise time. This minimizes the inrush current when the switch is enabled.

To implement the overcurrent protection, the protected circuit should be connected to the voltage supply via the SLG46116V P-FET. When the current in the protection circuit reaches the preset maximum current rating value, the GreenPAK device can almost instantly turn off the P-FET power switch and stop the flow of “overcurrent”. See the block diagram in Figure 2.

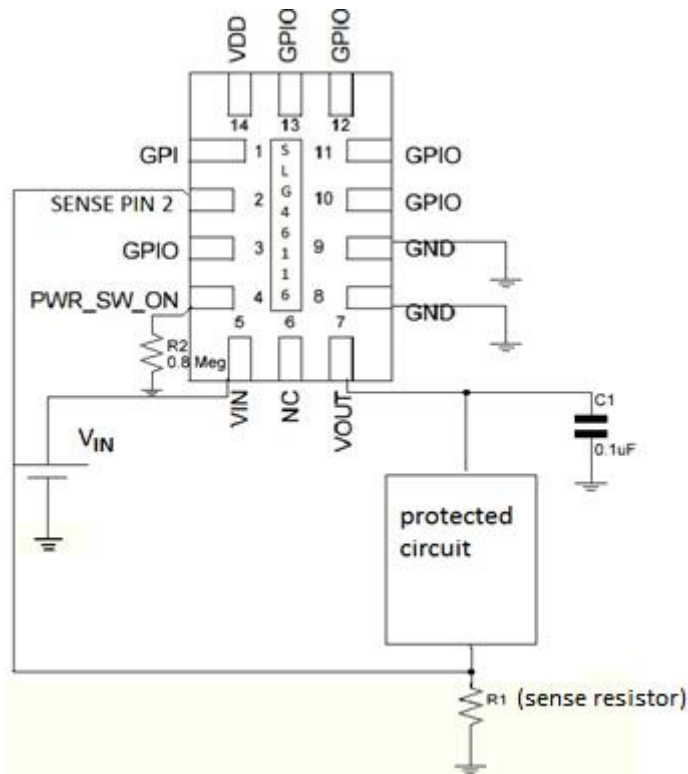

Figure 2. Overcurrent Protection Application Circuit with the SLG46116V

The GreenPAK design is shown in Figure 3. Besides the P-FET switch, the design requires additional components - one ACMP, one 2-bit LUT, and one DLY.

To use the ACMP in the GreenPAK design, the power-up signal (PWR UP) needs to be active (HIGH). Before the power-up signal POR, the ACMP is powered down. Its output is LOW, the output of LUT2 is also LOW, and the ON signal of P-FET is inactive. After the power-up signal POR, if the current does not exceed the rated limit, then the ON signal will be active (HIGH), and the switch will be closed providing the power supply to the connected circuit.

The overcurrent limit threshold can be programmed/designed by selecting the external resistor R1 shown in Figure 2. External resistor R1 is connected between the protected circuit and GND. It is also possible to select the IN-Vref value of ACMP, which has 24 internal reference sources (50 mV – 1200 mV) and V_{DD}/3, V_{DD}/4, PIN 4.

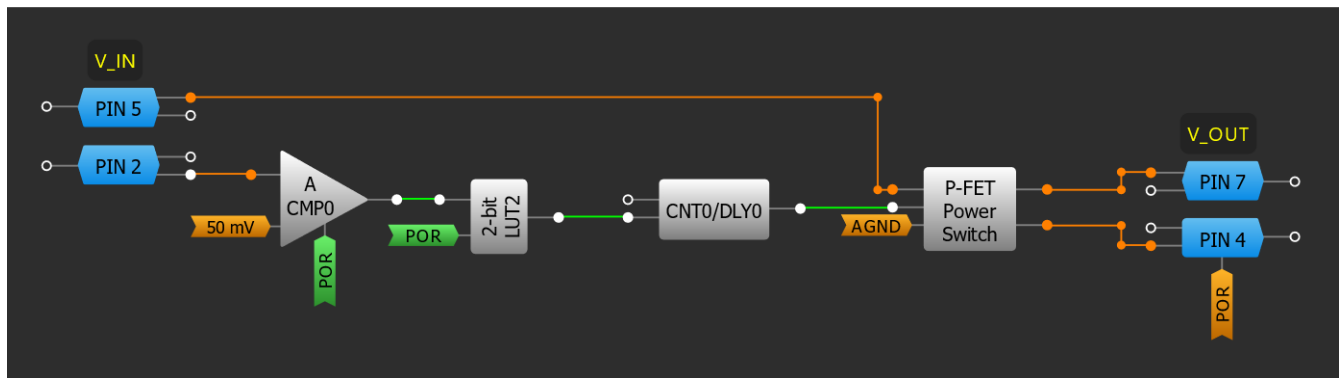

Figure 3. Overcurrent Protection Circuit GreenPAK Design

The current limit can be calculated as the I_{N-} V_{ref} divided by the external resistor R_1 . In this design example, I_{N-} is 50 mV and $R_1 = 0.2 \Omega$, therefore the current limit is equal to 250 mA.

If the current exceeds 250 mA, the output of ACMP is LOW, the ON signal is LOW (inactive), and the P-FET switch is open, therefore the overcurrent flow is interrupted.

When the overcurrent problem is interrupted, the delay time of DLY0 (adjustable) will define the recovery time, after which the P-FET will switch into the ON position and the protected circuit will resume being powered. If the overcurrent is unresolved, this can cause a continuous cycle of switching on and off the P-FET.

As a result, an overcurrent protection device can be easily implemented using Power GreenPAK that includes the P-FET Power Switch. It has low power consumption and few external components.

6. Conclusion

Renesas Power GreenPAK platform stands out as a versatile and efficient solution for modern power management needs. Its integration of configurable macrocells and load switches, supporting up to 2 A, ensures robust power control, protection, and distribution across various applications. The platform's flexibility, combined with the ease of configuration provided by the GreenPAK Designer, allows for the rapid development of customized power solutions. By addressing key market challenges, such as energy saving, component protection, compactness, and integration, the GreenPAK platform enhances system performance and reliability in a wide array of electronic devices, from consumer electronics to industrial and automotive systems. As the demand for efficient power management continues to grow, the Power GreenPAK platform is well-positioned to meet these needs, providing a reliable and effective approach to modern power system design.

7. Revision History

Revision	Date	Description
1.00	August 9, 2024	Initial release.

IMPORTANT NOTICE AND DISCLAIMER

RENESAS ELECTRONICS CORPORATION AND ITS SUBSIDIARIES (“RENESAS”) PROVIDES TECHNICAL SPECIFICATIONS AND RELIABILITY DATA (INCLUDING DATASHEETS), DESIGN RESOURCES (INCLUDING REFERENCE DESIGNS), APPLICATION OR OTHER DESIGN ADVICE, WEB TOOLS, SAFETY INFORMATION, AND OTHER RESOURCES “AS IS” AND WITH ALL FAULTS, AND DISCLAIMS ALL WARRANTIES, EXPRESS OR IMPLIED, INCLUDING, WITHOUT LIMITATION, ANY IMPLIED WARRANTIES OF MERCHANTABILITY, FITNESS FOR A PARTICULAR PURPOSE, OR NON-INFRINGEMENT OF THIRD-PARTY INTELLECTUAL PROPERTY RIGHTS.

These resources are intended for developers who are designing with Renesas products. You are solely responsible for (1) selecting the appropriate products for your application, (2) designing, validating, and testing your application, and (3) ensuring your application meets applicable standards, and any other safety, security, or other requirements. These resources are subject to change without notice. Renesas grants you permission to use these resources only to develop an application that uses Renesas products. Other reproduction or use of these resources is strictly prohibited. No license is granted to any other Renesas intellectual property or to any third-party intellectual property. Renesas disclaims responsibility for, and you will fully indemnify Renesas and its representatives against, any claims, damages, costs, losses, or liabilities arising from your use of these resources. Renesas' products are provided only subject to Renesas' Terms and Conditions of Sale or other applicable terms agreed to in writing. No use of any Renesas resources expands or otherwise alters any applicable warranties or warranty disclaimers for these products.

(Disclaimer Rev.1.01)

Corporate Headquarters

TOYOSU FORESIA, 3-2-24 Toyosu,
Koto-ku, Tokyo 135-0061, Japan
www.renesas.com

Trademarks

Renesas and the Renesas logo are trademarks of Renesas Electronics Corporation. All trademarks and registered trademarks are the property of their respective owners.

Contact Information

For further information on a product, technology, the most up-to-date version of a document, or your nearest sales office, please visit www.renesas.com/contact-us/.