

**Description**

The ICS477-05 generates five high-quality, high-frequency clock outputs including two reference outputs from a low frequency pullable crystal. It is designed to replace crystals and crystal oscillators in most electronic systems.

Using Phase-Locked-Loop (PLL) techniques, the device runs from a fundamental mode, pullable crystal. It can replace multiple crystals and oscillators, saving board space and cost.

**Features**

- Packaged in 28-pin SSOP (QSOP)
- Available in Pb-free packaging
- Replaces a VCXO plus multiple crystals and oscillators
- On-chip patented VCXO pull range 200 ppm (minimum)
- Duty cycle of 45/55
- Operating voltage of 3.3V
- Advanced, low power, CMOS process
- Input crystal frequency of 27 MHz
- Five output clocks
- Industrial temperature range available

**Block Diagram**

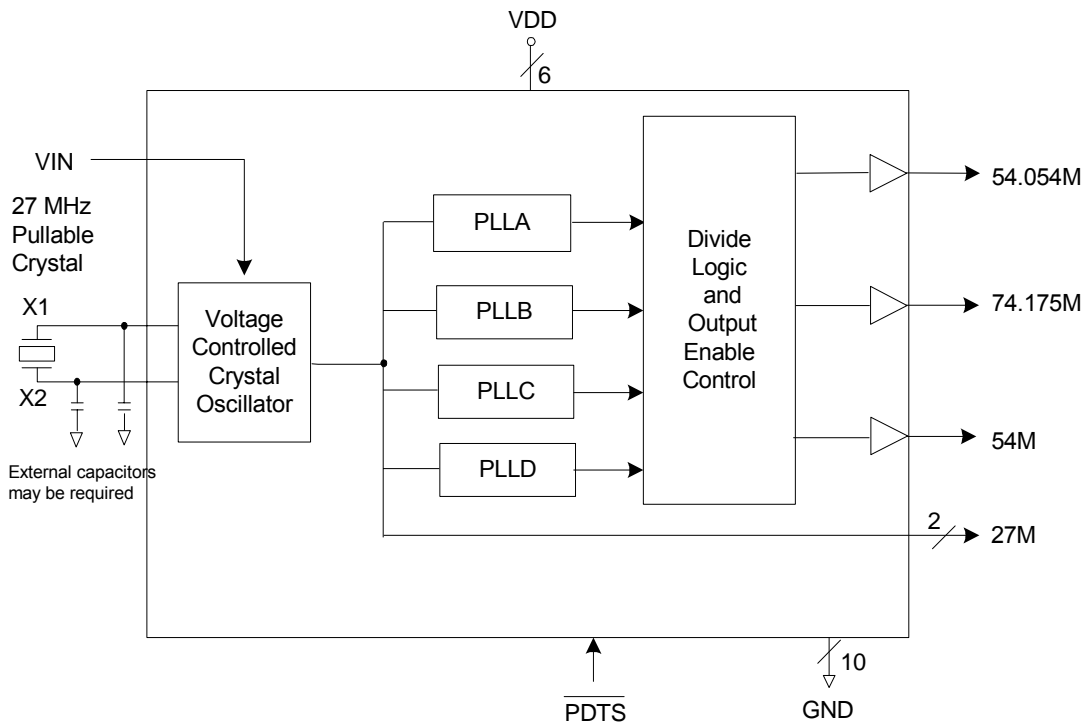

## Pin Assignment

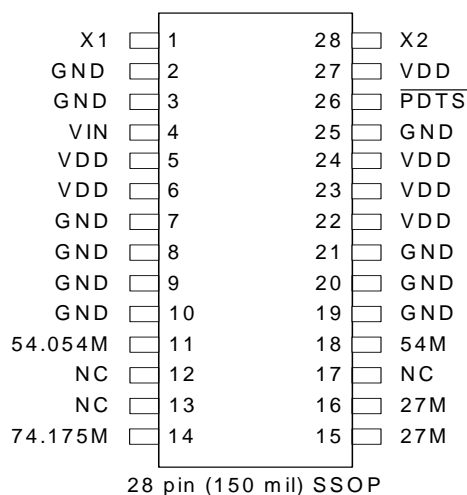

## Pin Descriptions

Pin Number	Pin Name	Pin Type	Pin Description
1	X1	Input	Crystal connection. Connect to a 27 MHz fundamental mode pullable crystal.
2	GND	Power	Connect to ground.
3	GND	Power	Connect to ground.
4	VIN	Input	VCXO Voltage input. Zero to 3.3 V analog control voltage for VCXO.
5, 6, 22, 23, 24, 27	VDD	Power	Connect to +3.3 V.
7, 8, 9, 10, 19, 20, 21	GND	Power	Connect to ground.
11	54.054M	Output	54.054 MHz clock output. Weak internal pull-down when tri-state.
12, 13, 17	NC	-	No connect. Do not connect anything to these pins.
14	74.175M	Output	74.175 MHz clock output. Weak internal pull-down when tri-state.
15, 16	27M	Output	27 MHz reference clock output. Weak internal pull-down when tri-state.
18	54M	Output	54 MHz clock output. Weak internal pull-down when tri-state.
25	GND	Power	Connect to ground.
26	$\overline{\text{PDTs}}$	Input	Powers down entire chip. Tri-states CLK outputs when low. Internal pull-up.
28	X2	Input	Crystal connection. Connect to a 27 MHz fundamental mode pullable crystal.

## External Components

The ICS477-05 requires a minimum number of external components for proper operation.

### Decoupling Capacitors

Decoupling capacitors of 0.01 $\mu$ F must be connected between VDD and GND, as close to these pins as possible. For optimum device performance, the decoupling capacitors should be mounted on the component side of the PCB. Avoid the use of vias in the decoupling circuit.

### Series Termination Resistor

When the PCB trace between the clock outputs and the loads are over 1 inch, series termination should be used. To series terminate a 50 $\Omega$  trace (a commonly used trace impedance) place a 33 $\Omega$  resistor in series with the clock line, as close to the clock output pin as possible. The nominal impedance of the clock output is 20 $\Omega$ .

### Quartz Crystal

The ICS477-05 VCXO function consists of the external crystal and the integrated VCXO oscillator circuit. To assure the best system performance (frequency pull range) and reliability, a crystal device with the recommended parameters (shown below) must be used, and the layout guidelines discussed in the following section must be followed.

The frequency of oscillation of a quartz crystal is determined by its "cut" and by the load capacitors connected to it. The ICS477-05 incorporates on-chip variable load capacitors that "pull" (change) the frequency of the crystal. The crystal specified for use with the ICS477-05 is designed to have zero frequency error when the total of on-chip + stray capacitance is 14 pF.

The external crystal must be connected as close to the chip as possible and should be on the same side of the PCB as the ICS477-05. There should be no via's between the crystal pins and the X1 and X2 device pins. There should be no signal traces underneath or close to the crystal.

**See application note MAN05 for complete crystal specifications.**

## Crystal Tuning Load Capacitors

The crystal traces should include pads for small fixed capacitors, one between X1 and ground, and another between X2 and ground. Stuffing of these capacitors on the PCB is optional. The need for these capacitors is determined at system prototype evaluation, and is influenced by the particular crystal used (manufacture and frequency) and by PCB layout. The typical required capacitor value is 1 to 4 pF.

To determine the need for and value of the crystal adjustment capacitors, you will need a PC board of your final layout, a frequency counter capable of about 1 ppm resolution and accuracy, two power supplies, and some samples of the crystals which you plan to use in production, along with measured initial accuracy for each crystal at the specified crystal load capacitance, CL.

To determine the value of the crystal capacitors:

1. Connect VDD of the ICS477-05 to 3.3 V. Connect pin 4 of the ICS477-05 to the second power supply. Adjust the voltage on pin 3 to 0V. Measure and record the frequency of the 27 MHz output.
2. Adjust the voltage on pin 4 to 3.3 V. Measure and record the frequency of the same output.

To calculate the centering error:

$$\text{Error} = 10^6 \times \left[ \frac{(f_{3.0V} - f_{\text{target}}) + (f_{0V} - f_{\text{target}})}{f_{\text{target}}} \right] - \text{error}_{\text{xtal}}$$

Where:

$f_{\text{target}}$  = nominal crystal frequency

$\text{error}_{\text{xtal}}$  = actual initial accuracy (in ppm) of the crystal being measured

If the centering error is less than  $\pm 25$  ppm, no adjustment is needed. If the centering error is more than 25 ppm negative, the PC board has excessive stray capacitance and a new PCB layout should be

considered to reduce stray capacitance. (Alternately, the crystal may be re-specified to a higher load capacitance. Contact ICS for details.) If the centering error is more than 25 ppm positive, add identical fixed centering capacitors from each crystal pin to ground. The value for each of these caps (in pF) is given by:

External Capacitor =

$$2 \times (\text{centering error}) / (\text{trim sensitivity})$$

Trim sensitivity is a parameter which can be supplied by your crystal vendor. If you do not know the value, assume it is 30 ppm/pF. After any changes, repeat the measurement to verify that the remaining error is acceptably low (typically less than  $\pm 25$  ppm).

## PCB Layout Recommendations

For optimum device performance and lowest output phase noise, the following guidelines should be observed.

- 1) The 0.01 $\mu$ F decoupling capacitors should be mounted on the component side of the board as close to the VDD pins as possible. No vias should be used between the decoupling capacitors and VDD pins. The PCB trace to VDD pin should be kept as short as possible, as should the PCB trace to the ground via.
- 2) The external crystal should be mounted just next to the device with short traces. The X1 and X2 traces should not be routed next to each other with minimum

spaces, instead they should be separated and away from other traces.

- 3) To minimize EMI, the 33 $\Omega$  series termination resistor (if needed) should be placed close to the clock output.
- 4) An optimum layout is one with all components on the same side of the board, minimizing vias through other signal layers. Other signal traces should be routed away from the ICS477-05. This includes signal traces just underneath the device, or on layers adjacent to the ground plane layer used by the device.

## Absolute Maximum Ratings

Stresses above the ratings listed below can cause permanent damage to the ICS477-05. These ratings, which are standard values for ICS commercially rated parts, are stress ratings only. Functional operation of the device at these or any other conditions above those indicated in the operational sections of the specifications is not implied. Exposure to absolute maximum rating conditions for extended periods can affect product reliability. Electrical parameters are guaranteed only over the recommended operating temperature range.

Item	Rating
Supply Voltage, VDD	7 V
All Inputs and Outputs	-0.5 V to VDD+0.5 V
Ambient Operating Temperature (commercial)	0 to +70° C
Ambient Operating Temperature (industrial)	-40 to +85° C
Storage Temperature	-65 to +150° C
Junction Temperature	125° C
Soldering Temperature	260° C

## Recommended Operation Conditions

Parameter	Min.	Typ.	Max.	Units
Ambient Operating Temperature	-40		+85	°C
Power Supply Voltage (measured in respect to GND)	+3.15	+3.3	+3.45	V

## DC Electrical Characteristics

Unless stated otherwise, **VDD = 3.3 V ±5%**, Ambient Temperature -40 to +85° C

Parameter	Symbol	Conditions	Min.	Typ.	Max.	Units
Operating Voltage	VDD		3.15	3.3	3.45	V
Supply Current	IDD	No load		48		mA
Power Down Current	IDDPD	No load		0.5		mA
Input High Voltage	V <sub>IH</sub>	$\overline{\text{PDT}}\overline{\text{S}}$ pin	2			V
Input Low Voltage	V <sub>IL</sub>	$\overline{\text{PDT}}\overline{\text{S}}$ pin			0.8	V
Output High Voltage	V <sub>OH</sub>	I <sub>OH</sub> = -4 mA	VDD-0.4			V
Output High Voltage	V <sub>OH</sub>	I <sub>OH</sub> = -12 mA	2.4			V
Output Low Voltage	V <sub>OL</sub>	I <sub>OL</sub> = 12 mA			0.4	V
Short Circuit Current	I <sub>OS</sub>	CLK output		±80		mA
Input Capacitance, inputs	C <sub>IN</sub>			5		pF
Nominal Output Impedance	Z <sub>OUT</sub>			20		Ω
Internal Pull-up Resistor	R <sub>PUP</sub>	$\overline{\text{PDT}}\overline{\text{S}}$ pin		360		kΩ
Internal Pull-down Resistor	R <sub>PD</sub>	CLK outputs		510		kΩ

## AC Electrical Characteristics

Unless stated otherwise, **VDD = 3.3 V ±5%**, Ambient Temperature -40 to +85° C

Parameter	Symbol	Conditions	Min.	Typ.	Max.	Units
Input Frequency	f <sub>in</sub>	Crystal input, Note 2		27		MHz
Crystal Pullability	F <sub>P</sub>	0V ≤ VIN ≤ 3.3 V	±100			ppm
VCXO Gain	K <sub>0</sub>	VIN = VDD/2 ± 1 V		150		ppm/V
Output Rise Time	t <sub>OR</sub>	20% to 80%, Note 1		1.2		ns
Output Fall Time	t <sub>OF</sub>	80% to 20%, Note 1		1.0		ns
Clock Stabilization Time after Power-up					10	ms
Cycle Jitter (short term jitter)	t <sub>ja</sub>			±200		ps

Parameter	Symbol	Conditions	Min.	Typ.	Max.	Units
Long Term Jitter		54.054M, 54M clocks		1.0		ns
		74.175M clock		1.3		ns
		27M reference clock		300		ps
Output Enable Time		$\overline{\text{PDTS}}$ high to output locked to $\pm 1\%$		250		$\mu\text{s}$
Output Disable Time		$\overline{\text{PDTS}}$ low to tri-state		20		ns

Note 1: Measured with a 15 pF load.

Note 2: With an ICS approved crystal.

### Marking Diagram

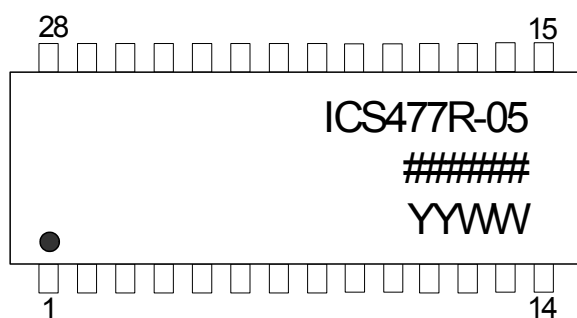

### Marking Diagram (Pb free)

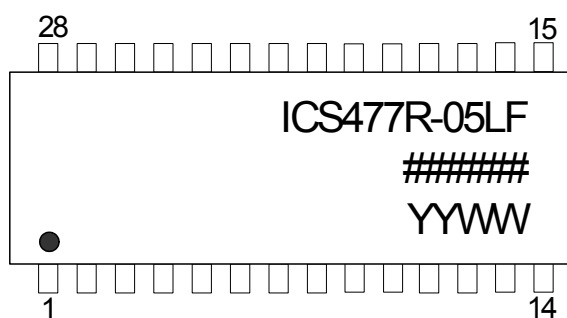

### Marking Diagram (industrial)

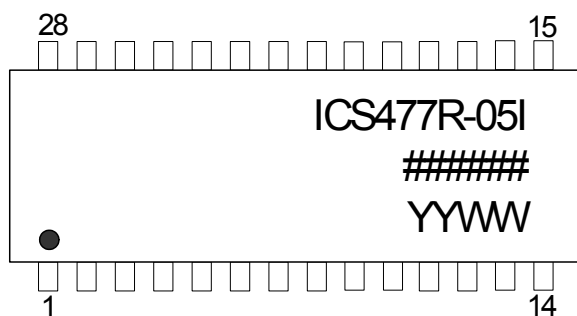

### Marking Diagram (Pb free, industrial)

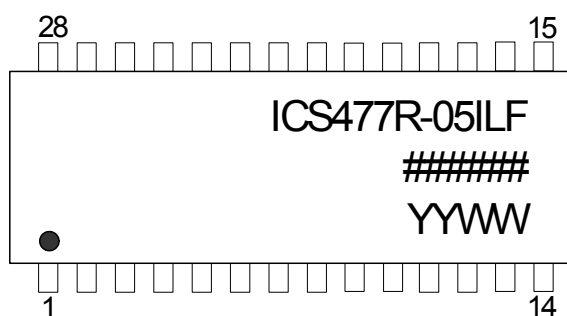

Notes:

1. ##### is the lot code.
2. YYWW is the last two digits of the year, and the week.
3. "LF" designates Pb (lead) free.
4. "I" designates industrial temperature grade.

## Package Outline and Package Dimensions (28-pin SSOP, 150 Mil. Body)

Package dimensions are kept current with JEDEC Publication No. 95

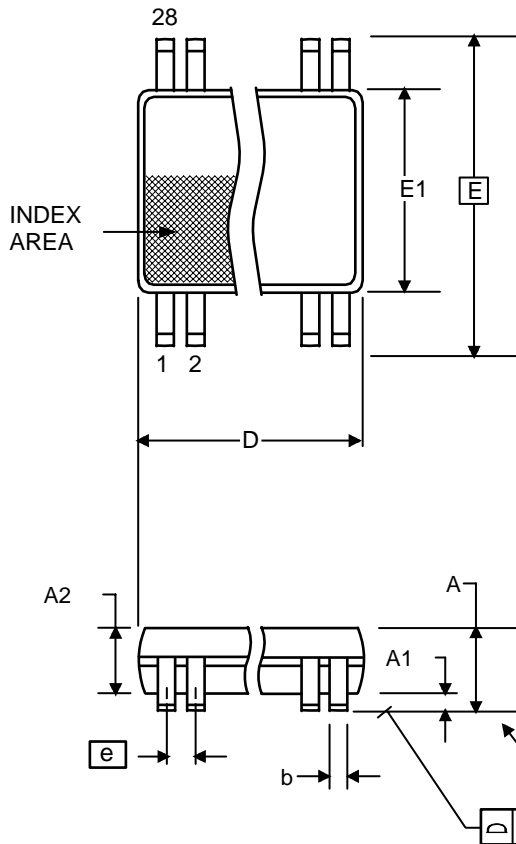

Symbol	Millimeters		Inches	
	Min	Max	Min	Max
A	1.35	1.75	.053	.069
A1	0.10	0.25	.0040	.010
A2	--	1.50	--	.059
b	0.20	0.30	0.008	0.012
C	0.18	0.25	.007	.010
D	9.80	10.00	.386	.394
E	5.80	6.20	.228	.244
E1	3.80	4.00	.150	.157
e	0.635 Basic		0.025 Basic	
L	0.40	1.27	.016	.050
$\alpha$	0°	8°	0°	8°

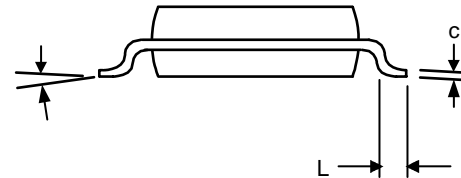

## Ordering Information

Part / Order Number	Marking	Shipping Packaging	Package	Temperature
477R-05	ICS477R-05 (top line)	Tubes	28-pin SSOP	0 to +70° C
477R-05T	YYWW (3rd line)	Tape and Reel	28-pin SSOP	0 to +70° C
477R-05I	ICS477R-05I (top line)	Tubes	28-pin SSOP	-40 to +85° C
477R-05IT	YYWW (3rd line)	Tape and Reel	28-pin SSOP	-40 to +85° C
477R-05LF	ICS477R-05LF (top line)	Tubes	28-pin SSOP	0 to +70° C
477R-05LFT	YYWW (3rd line)	Tape and Reel	28-pin SSOP	0 to +70° C
477R-05ILF	ICS477R-05ILF (top line)	Tubes	28-pin SSOP	-40 to +85° C
477R-05ILFT	YYWW (3rd line)	Tape and Reel	28-pin SSOP	-40 to +85° C

"LF" denotes Pb (lead) free package.

While the information presented herein has been checked for both accuracy and reliability, Integrated Circuit Systems (ICS) assumes no responsibility for either its use or for the infringement of any patents or other rights of third parties, which would result from its use. No other circuits, patents, or licenses are implied. This product is intended for use in normal commercial applications. Any other applications such as those requiring extended temperature range, high reliability, or other extraordinary environmental requirements are not recommended without additional processing by ICS. ICS reserves the right to change any circuitry or specifications without notice. ICS does not authorize or warrant any ICS product for use in life support devices or critical medical instruments.





## IMPORTANT NOTICE AND DISCLAIMER

RENESAS ELECTRONICS CORPORATION AND ITS SUBSIDIARIES (“RENESAS”) PROVIDES TECHNICAL SPECIFICATIONS AND RELIABILITY DATA (INCLUDING DATASHEETS), DESIGN RESOURCES (INCLUDING REFERENCE DESIGNS), APPLICATION OR OTHER DESIGN ADVICE, WEB TOOLS, SAFETY INFORMATION, AND OTHER RESOURCES “AS IS” AND WITH ALL FAULTS, AND DISCLAIMS ALL WARRANTIES, EXPRESS OR IMPLIED, INCLUDING, WITHOUT LIMITATION, ANY IMPLIED WARRANTIES OF MERCHANTABILITY, FITNESS FOR A PARTICULAR PURPOSE, OR NON-INFRINGEMENT OF THIRD-PARTY INTELLECTUAL PROPERTY RIGHTS.

These resources are intended for developers who are designing with Renesas products. You are solely responsible for (1) selecting the appropriate products for your application, (2) designing, validating, and testing your application, and (3) ensuring your application meets applicable standards, and any other safety, security, or other requirements. These resources are subject to change without notice. Renesas grants you permission to use these resources only to develop an application that uses Renesas products. Other reproduction or use of these resources is strictly prohibited. No license is granted to any other Renesas intellectual property or to any third-party intellectual property. Renesas disclaims responsibility for, and you will fully indemnify Renesas and its representatives against, any claims, damages, costs, losses, or liabilities arising from your use of these resources. Renesas' products are provided only subject to Renesas' Terms and Conditions of Sale or other applicable terms agreed to in writing. No use of any Renesas resources expands or otherwise alters any applicable warranties or warranty disclaimers for these products.

(Disclaimer Rev.1.01 Jan 2024)

### Corporate Headquarters

TOYOSU FORESIA, 3-2-24 Toyosu,  
Koto-ku, Tokyo 135-0061, Japan  
[www.renesas.com](http://www.renesas.com)

### Trademarks

Renesas and the Renesas logo are trademarks of Renesas Electronics Corporation. All trademarks and registered trademarks are the property of their respective owners.

### Contact Information

For further information on a product, technology, the most up-to-date version of a document, or your nearest sales office, please visit [www.renesas.com/contact-us/](http://www.renesas.com/contact-us/).