

General Description

The 8725B-21 is a highly versatile 1:1 Differential-to-HSTL Clock Generator. The CLK, nCLK pair can accept most standard differential input levels. The 8725B-21 has a fully integrated PLL and can be configured as zero delay buffer, multiplier or divider, and has an output frequency range of 31.25MHz to 630MHz. The reference divider, feedback divider and output divider are each programmable, thereby allowing for the following output-to-input frequency ratios: 8:1, 4:1, 2:1, 1:1, 1:2, 1:4, 1:8. The external feedback allows the device to achieve “zero delay” between the input clock and the output clocks. The PLL_SEL pin can be used to bypass the PLL for system test and debug purposes. In bypass mode, the reference clock is routed around the PLL and into the internal output dividers.

Features

- One differential HSTL output pair
- One differential feedback output pair
- Differential CLK, nCLK input pair
- CLK, nCLK pair can accept the following differential input levels: LVPECL, LVDS, HSTL, HCSL, SSTL
- Output frequency range: 31.25MHz to 630MHz
- Input frequency range: 31.25MHz to 630MHz
- VCO range: 250MHz to 630MHz
- External feedback for “zero delay” clock regeneration with configurable frequencies
- Programmable dividers allow for the following output-to-input frequency ratios: 8:1, 4:1, 2:1, 1:1, 1:2, 1:4, 1:8
- Cycle-to-cycle jitter: 50ps (maximum)
- Output skew: 50ps (maximum)
- Static phase offset: 200ps (maximum)
- 3.3V core, 1.8V output operating supply
- 0°C to 70°C ambient operating temperature

Block Diagram

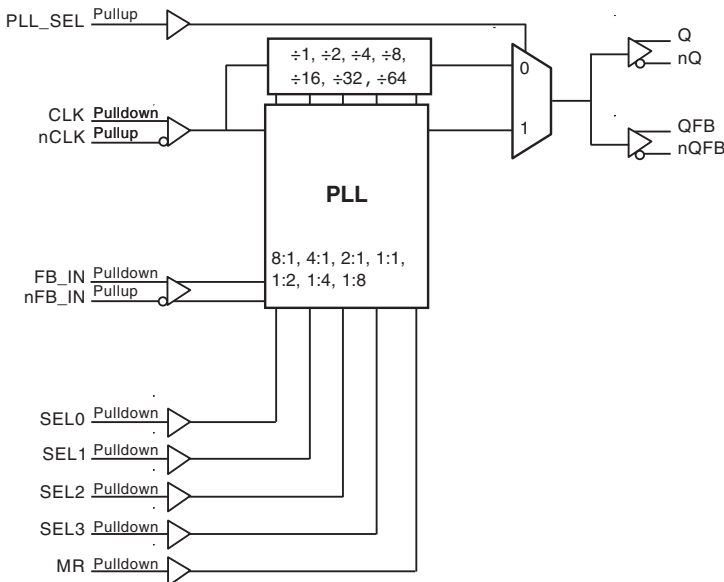

Pin Assignment

CLK	1	20	nc
nCLK	2	19	SEL1
MR	3	18	SEL0
VDD	4	17	VDD
nFB_IN	5	16	PLL_SEL
FB_IN	6	15	VDDA
SEL2	7	14	SEL3
GND	8	13	VDDO
nQFB	9	12	Q
QFB	10	11	nQ

8725B-21
20-Lead SOIC
7.5mm x 12.8mm package body

Pin Descriptions and Characteristics

Table 1. Pin Descriptions¹

Number	Name	Type		Description
1	CLK	Input	Pulldown	Non-inverting differential clock input.
2	nCLK	Input	Pullup	Inverting differential clock input.
3	MR	Input	Pulldown	Active HIGH Master Reset. When logic HIGH, the internal dividers are reset causing the true outputs Q and QFB to go low and the inverted outputs nQ and nQFB to go high. When logic LOW, the internal dividers and the outputs are enabled. LVCMOS / LVTTTL interface levels.
4	V _{DD}	Power		Core supply pins.
5	nFB_IN	Input	Pullup	Inverting differential feedback input to phase detector for regenerating clocks with “Zero Delay.” Connect to pin 9.
6	FB_IN	Input	Pulldown	Non-inverted differential feedback input to phase detector for regenerating clocks with “Zero Delay.” Connect to pin 10.
7	SEL2	Input	Pulldown	Determines output divider values in Table 3. LVCMOS / LVTTTL interface levels.
8	GND	Power		Power supply ground.
9	nQFB	Output		Inverting differential feedback output. HSTL interface levels.
10	QFB	Output		Non-inverting differential feedback output. HSTL interface levels.
11	nQ	Output		Inverting differential output. HSTL interface levels.
12	Q	Output		Non-inverting differential output. HSTL interface levels.
13	V _{DDO}	Power		Output supply pin.
14	SEL3	Input	Pulldown	Determines output divider values in Table 3. LVCMOS / LVTTTL interface levels.
15	V _{DDA}	Power		Analog supply pin.
16	PLL_SEL	Input	Pullup	PLL select. Selects between the PLL and reference clock as the input to the dividers. When LOW, selects reference clock. When HIGH, selects PLL. LVCMOS/LVTTTL interface levels.
17	V _{DD}	Power		Core supply pins.
18	SEL0	Input	Pulldown	Determines output divider values in Table 3. LVCMOS / LVTTTL interface levels.
19	SEL1	Input	Pulldown	Determines output divider values in Table 3. LVCMOS / LVTTTL interface levels.
20	nc	Unused		No connect.

NOTE 1. *Pullup* and *Pulldown* refer to internal input resistors. See [Table 2, Pin Characteristics](#), for typical values.

Table 2. Pin Characteristics

Symbol	Parameter	Test Conditions	Minimum	Typical	Maximum	Units
C _{IN}	Input Capacitance			4		pF
R _{PULLUP}	Input Pullup Resistor			51		kΩ
R _{PULLDOWN}	Input Pulldown Resistor			51		kΩ

Function Tables

Table 3A. Control Input Function Table

Inputs					Outputs PLL_SEL = 1 PLL Enable Mode
SEL3	SEL2	SEL1	SEL0	Reference Frequency Range (MHz)	Q, nQ
0	0	0	0	250 - 630	÷1
0	0	0	1	125 - 315	÷1
0	0	1	0	62.5 - 157.5	÷1
0	0	1	1	31.25 - 78.75	÷1
0	1	0	0	250 - 630	÷2
0	1	0	1	125 - 315	÷2
0	1	1	0	62.5 - 157.5	÷2
0	1	1	1	250 - 630	÷4
1	0	0	0	125 - 315	÷4
1	0	0	1	250 - 630	÷8
1	0	1	0	125 - 315	x2
1	0	1	1	62.5 - 157.5	x2
1	1	0	0	31.25 - 78.75	x2
1	1	0	1	62.5 - 157.5	x4
1	1	1	0	31.25 - 78.75	x4
1	1	1	1	31.25 - 78.75	x8

Table 3B. PLL Bypass Function Table

Inputs				Outputs PLL_SEL = 0 PLL Bypass Mode
SEL3	SEL2	SEL1	SEL0	Q, nQ, QFB, nQFB
0	0	0	0	÷4
0	0	0	1	÷4
0	0	1	0	÷4
0	0	1	1	÷8
0	1	0	0	÷8
0	1	0	1	÷8
0	1	1	0	÷16
0	1	1	1	÷16
1	0	0	0	÷32
1	0	0	1	÷64
1	0	1	0	÷2
1	0	1	1	÷2
1	1	0	0	÷4
1	1	0	1	÷1
1	1	1	0	÷2
1	1	1	1	÷1

Absolute Maximum Ratings

NOTE: Stresses beyond those listed under *Absolute Maximum Ratings* may cause permanent damage to the device. These ratings are stress specifications only. Functional operation of the product at these conditions or any conditions beyond those listed in the *DC Characteristics* or *AC Characteristics* is not implied. Exposure to absolute maximum rating conditions for extended periods may affect product reliability.

Item	Rating
Supply Voltage, V_{DD}	4.6V
Inputs, V_I	-0.5V to $V_{DD} + 0.5V$
Outputs, V_O	-0.5V to $V_{DDO} + 0.5V$
Package Thermal Impedance, θ_{JA}	46.2°C/W (0 lfpm)
Storage Temperature, T_{STG}	-65°C to 150°C
Junction Temperature	125°C

DC Electrical Characteristics

Table 4A. Power Supply DC Characteristics, $V_{DD} = V_{DDA} = 3.3V \pm 5\%$, $V_{DDO} = 1.8V \pm 0.2V$, $T_A = 0^\circ C$ to $70^\circ C$

Symbol	Parameter	Test Conditions	Minimum	Typical	Maximum	Units
V_{DD}	Core Supply Voltage		3.135	3.3	3.465	V
V_{DDA}	Analog Supply Voltage		3.135	3.3	3.465	V
V_{DDO}	Output Supply Voltage		1.6	1.8	2.0	V
I_{DD}	Power Supply Current				137	mA
I_{DDA}	Analog Supply Current				17	mA
I_{DDO}	Output Supply Current	No Load		0		mA

Table 4B. LVCMOS/LVTTL DC Characteristics, $V_{DD} = V_{DDA} = 3.3V \pm 5\%$, $V_{DDO} = 1.8V \pm 0.2V$, $T_A = 0^\circ C$ to $70^\circ C$

Symbol	Parameter	Test Conditions	Minimum	Typical	Maximum	Units
V_{IH}	Input High Voltage		2		$V_{DD} + 0.3$	V
V_{IL}	Input Low Voltage		-0.3		0.8	V
I_{IH}	Input High Current	SEL[0:3], MR	$V_{DD} = V_{IN} = 3.465V$		150	μA
		PLL_SEL	$V_{DD} = V_{IN} = 3.465V$		5	μA
I_{IL}	Input Low Current	SEL[0:3], MR	$V_{DD} = 3.465V, V_{IN} = 0V$	-5		μA
		PLL_SEL	$V_{DD} = 3.465V, V_{IN} = 0V$	-150		μA

Table 4C. Differential DC Characteristics, $V_{DD} = V_{DDA} = 3.3V \pm 5\%$, $V_{DDO} = 1.8V \pm 0.2V$, $T_A = 0^\circ\text{C}$ to 70°C

Symbol	Parameter	Test Conditions	Minimum	Typical	Maximum	Units
I_{IH}	Input High Current	CLK, FB_IN	$V_{DD} = V_{IN} = 3.465V$		150	μA
		nCLK, nFB_IN	$V_{DD} = V_{IN} = 3.465V$		5	μA
I_{IL}	Input Low Current	CLK, FB_IN	$V_{DD} = 3.465V$, $V_{IN} = 0V$	-5		μA
		nCLK, nFB_IN	$V_{DD} = 3.465V$, $V_{IN} = 0V$	-150		μA
V_{PP}	Peak-to-Peak Voltage ¹		0.15		1.3	V
V_{CMR}	Common Mode Input Voltage ^{1, 2}		GND + 0.5		$V_{DD} - 0.85$	V

NOTE 1. V_{IL} should not be less than -0.3V.

NOTE 2. Common mode input voltage is defined as V_{IH} .

Table 4D. HSTL DC Characteristics, $V_{DD} = V_{DDA} = 3.3V \pm 5\%$, $V_{DDO} = 1.8V \pm 0.2V$, $T_A = 0^\circ\text{C}$ to 70°C

Symbol	Parameter	Test Conditions	Minimum	Typical	Maximum	Units
V_{OH}	Output High Voltage ¹		1.0		1.4	V
V_{OL}	Output Low Voltage ¹		0		0.4	V
V_{OX}	Output Crossover Voltage ²		40		60	%
V_{SWING}	Peak-to-Peak Output Voltage Swing		0.6		1.1	V

NOTE 1. Outputs termination with 50Ω to ground.

NOTE 2. Defined with respect to output voltage swing at a given condition.

Table 5. Input Frequency Characteristics, $V_{DD} = V_{DDA} = 3.3V \pm 5\%$, $V_{DDO} = 1.8V \pm 0.2V$, $T_A = 0^\circ\text{C}$ to 70°C

Symbol	Parameter	Test Conditions	Minimum	Typical	Maximum	Units
F_{IN}	Input Frequency	CLK, nCLK	PLL_SEL = 1	31.25	630	MHz
			PLL_SEL = 0		630	MHz

AC Electrical Characteristics

Table 6. AC Characteristics, $V_{DD} = V_{DDA} = 3.3V \pm 5\%$, $V_{DDO} = 1.8V \pm 0.2V$, $T_A = 0^\circ\text{C}$ to 70°C ^{1, 2}

Symbol	Parameter	Test Conditions	Minimum	Typical	Maximum	Units
f_{MAX}	Output Frequency				630	MHz
t_{PD}	Propagation Delay ³	PLL_SEL = 0V, $f \leq 630\text{MHz}$	3.2		4.5	ns
$t_{sk}(\emptyset)$	Static Phase Offset ^{4, 5}	PLL_SEL = 3.3V	-125	37.5	200	ps
$t_{sk}(o)$	Output Skew ^{5, 6}	PLL_SEL = 0V			50	ps
$f_{jit}(cc)$	Cycle-to-Cycle Jitter ^{5, 7}				50	ps
$f_{jit}(\theta)$	Phase Jitter ^{5, 7, 8}				± 50	ps
t_L	PLL Lock Time				1	ms
t_R / t_F	Output Rise/Fall Time	20% to 80% @ 50MHz	300		700	ps
t_{PW}	Output Pulse Width		$t_{PERIOD}/2 - 90$	$t_{PERIOD}/2$	$t_{PERIOD}/2 + 90$	ps

NOTE 1. Electrical parameters are guaranteed over the specified ambient operating temperature range, which is established when the device is mounted in a test socket with maintained transverse airflow greater than 500 lfm. The device will meet specifications after thermal equilibrium has been reached under these conditions.

NOTE 2. All parameters measured at f_{MAX} unless noted otherwise.

NOTE 3. Measured from the differential input crossing point to the differential output crossing point.

NOTE 4. Defined as the time difference between the input reference clock and the average feedback input signal, when the PLL is locked and the input reference frequency is stable.

NOTE 5. This parameter is defined in accordance with JEDEC Standard 65.

NOTE 6. Defined as skew between outputs at the same supply voltage and with equal load conditions. Measured at the output differential cross points.

NOTE 7. Characterized at VCO frequency of 622MHz.

NOTE 8. Phase jitter is dependent on the input source used.

Parameter Measurement Information

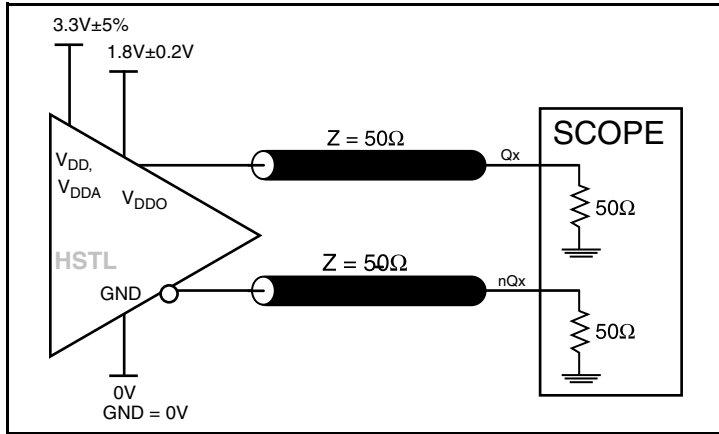

3.3V Core/1.8V Output Load AC Test Circuit

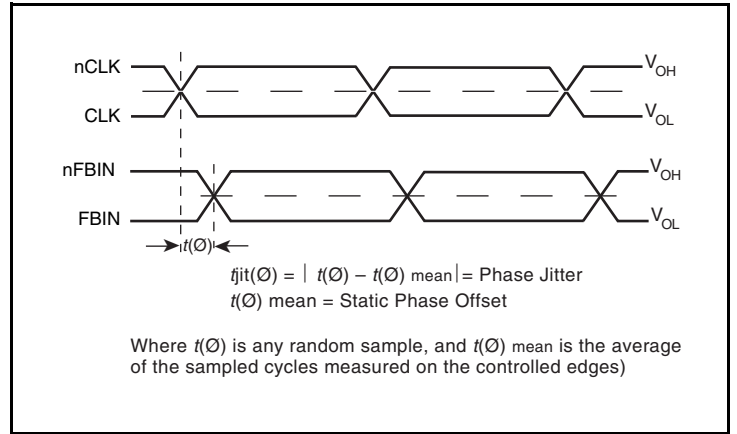

Phase Jitter and Static Phase Offset

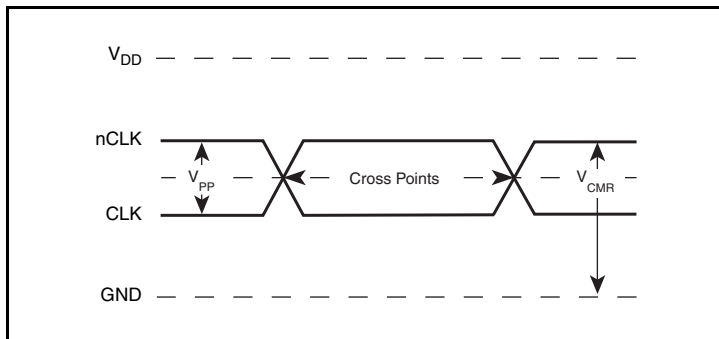

Differential Input Level

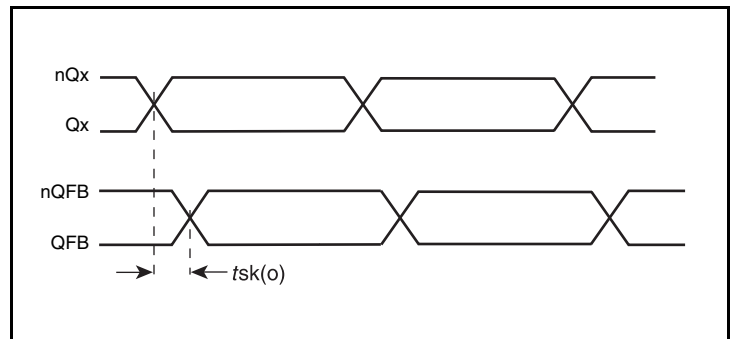

Output Skew

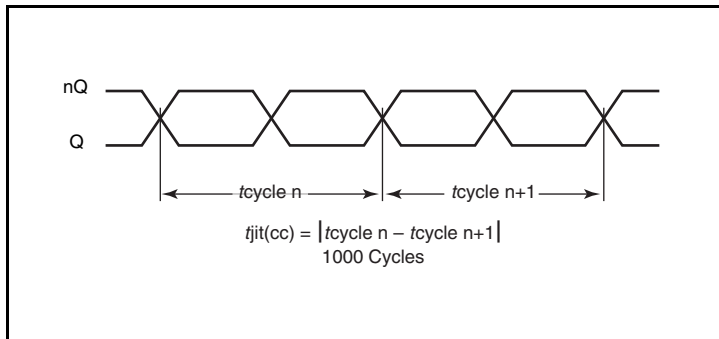

Cycle-to-Cycle Jitter

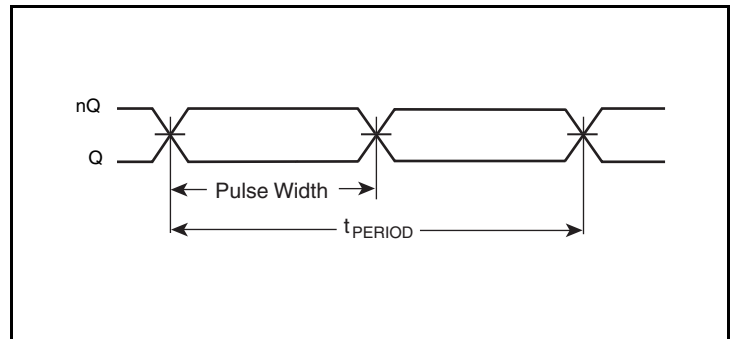

Output Pulse Width

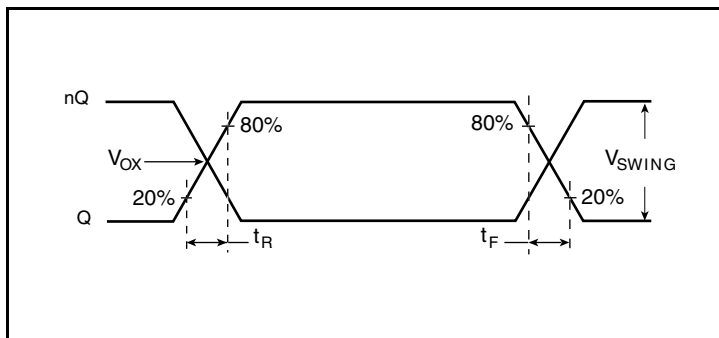

Output Rise/Fall Time

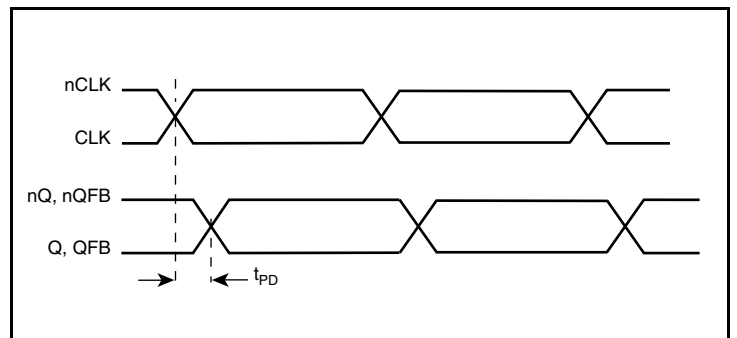

Propagation Delay

Applications Information

Recommendations for Unused Input Pins

Inputs:

LVC MOS Control Pins

All control pins have internal pull-ups or pull-downs; additional resistance is not required but can be added for additional protection. A 1kΩ resistor can be used.

Wiring the Differential Input to Accept Single-Ended Levels

Figure 1 shows how a differential input can be wired to accept single ended levels. The reference voltage $V_1 = V_{DD}/2$ is generated by the bias resistors R1 and R2. The bypass capacitor (C1) is used to help filter noise on the DC bias. This bias circuit should be located as close to the input pin as possible. The ratio of R1 and R2 might need to be adjusted to position the V_1 in the center of the input voltage swing. For example, if the input clock swing is 2.5V and $V_{DD} = 3.3V$, R1 and R2 value should be adjusted to set V_1 at 1.25V. The values below are for when both the single ended swing and V_{DD} are at the same voltage. This configuration requires that the sum of the output impedance of the driver (R_o) and the series resistance (R_s) equals the transmission line impedance. In addition, matched termination at the input will attenuate the signal in half. This can be done in one of two ways. First, R3 and R4 in parallel should equal the transmission line impedance. For most 50Ω applications, R3 and R4 can be 100Ω.

The values of the resistors can be increased to reduce the loading for slower and weaker LVC MOS driver. When using single-ended signaling, the noise rejection benefits of differential signaling are reduced. Even though the differential input can handle full rail LVC MOS signaling, it is recommended that the amplitude be reduced. The datasheet specifies a lower differential amplitude, however this only applies to differential signals. For single-ended applications, the swing can be larger, however V_{IL} cannot be less than -0.3V and V_{IH} cannot be more than $V_{DD} + 0.3V$. Suggested edge rate faster than 1V/ns. Though some of the recommended components might not be used, the pads should be placed in the layout. They can be utilized for debugging purposes. The datasheet specifications are characterized and guaranteed by using a differential signal.

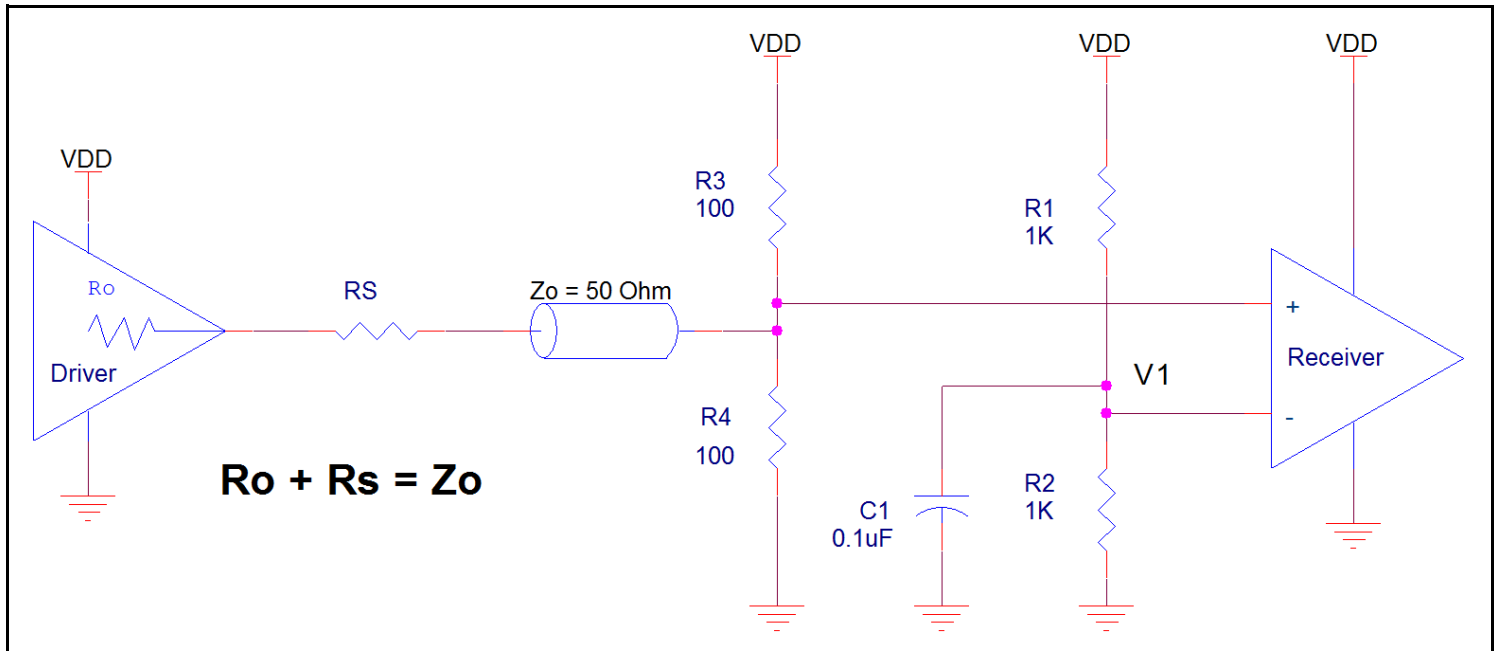

Figure 1. Recommended Schematic for Wiring a Differential Input to Accept Single-ended Levels

Differential Clock Input Interface

The CLK /nCLK accepts LVDS, LVPECL, HSTL, SSTL, HCSL and other differential signals. Both V_{SWING} and V_{OH} must meet the V_{PP} and V_{CMR} input requirements. [Figure 2A](#) to [Figure 2F](#) show interface examples for the CLK/nCLK input driven by the most common driver types. The input interfaces suggested here are examples only.

Please consult with the vendor of the driver component to confirm the driver termination requirements. For example, in [Figure 2A](#), the input termination applies for IDT open emitter HSTL drivers. If you are using an HSTL driver from another vendor, use their termination recommendation.

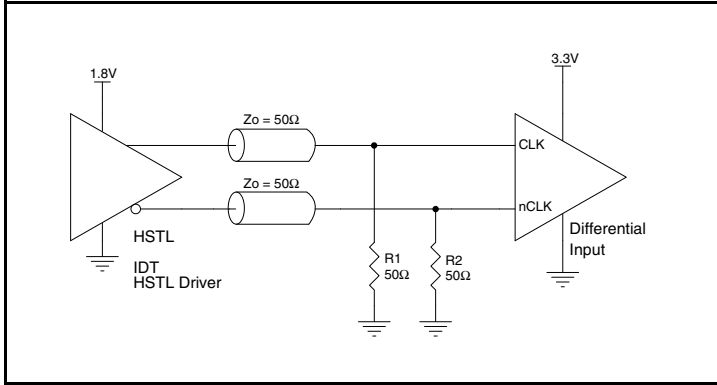

Figure 2A. CLK/nCLK Input Driven by an IDT Open Emitter HSTL Driver

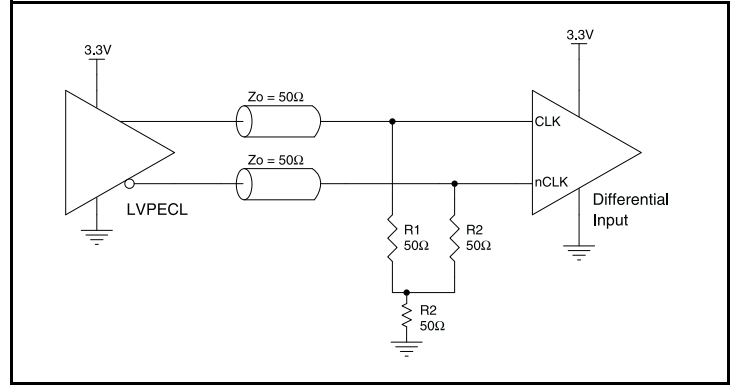

Figure 2D. CLK/nCLK Input Driven by a 3.3V LVPECL Driver

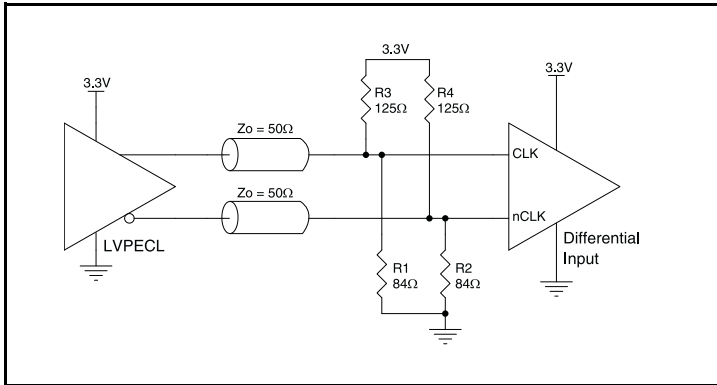

Figure 2B. CLK/nCLK Input Driven by a 3.3V LVPECL Driver

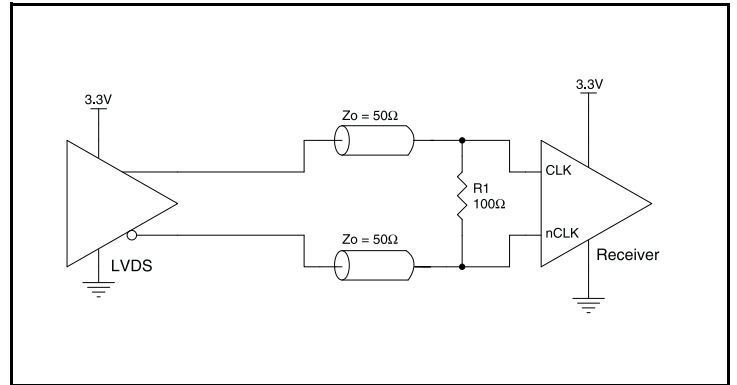

Figure 2E. CLK/nCLK Input Driven by a 3.3V LVDS Driver

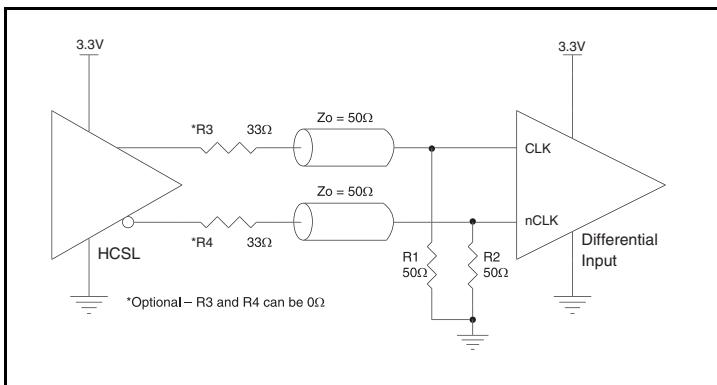

Figure 2C. CLK/nCLK Input Driven by a 3.3V HCSL Driver

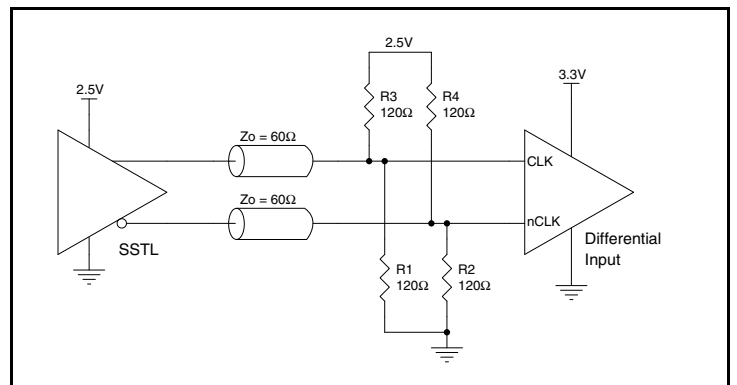

Figure 2F. CLK/nCLK Input Driven by a 2.5V SSTL Driver

Schematic Example

Figure 3 shows a schematic example of the 8725B-21. In this example, the input is driven by an HCSL driver. The zero delay buffer is configured to operate at 155.52MHz input and 77.75MHz output. The logic control pins are configured as follows:

SEL[3:0] = 0101
 PLL_SEL = 1

For 8725B-21, the decoupling capacitors should be physically located near the power pin.

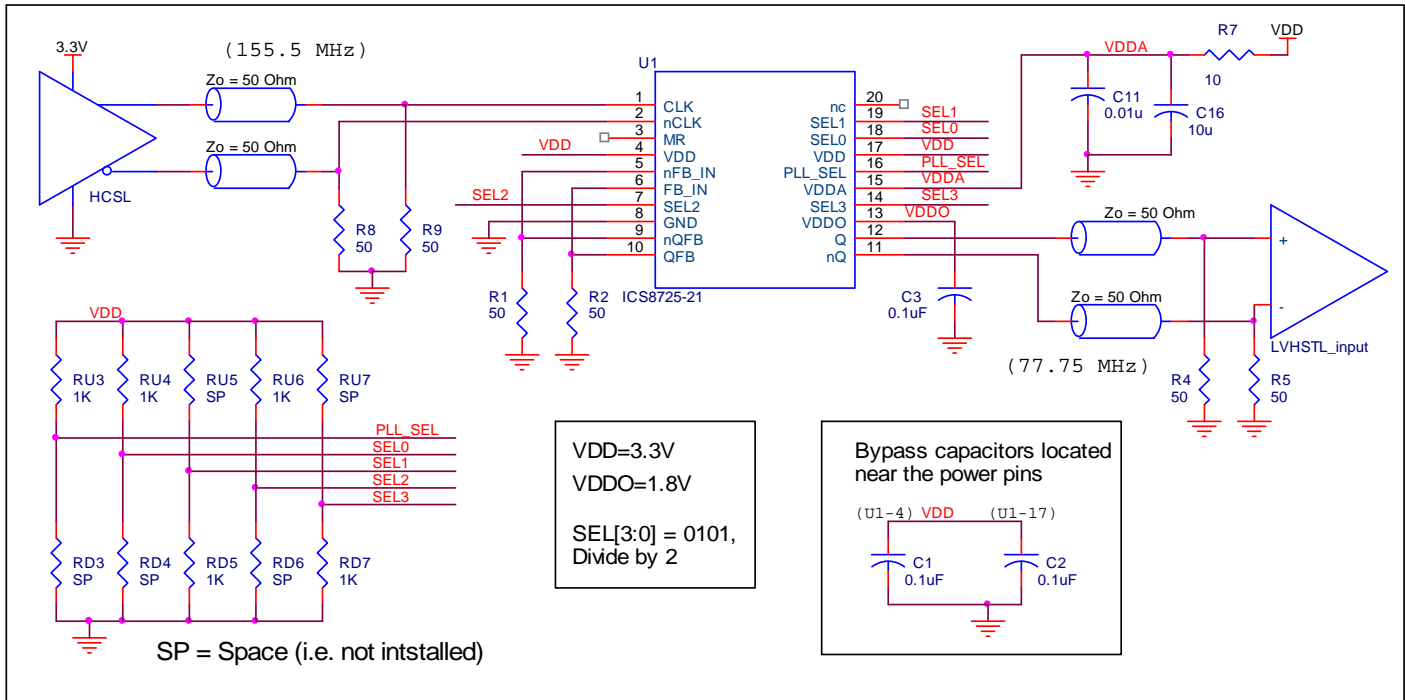

Figure 3. 8725B-21 HSTL Buffer Schematic Example

Power Considerations

This section provides information on power dissipation and junction temperature for the 8725B-21. Equations and example calculations are also provided.

1. Power Dissipation.

The total power dissipation for the 8725B-21 is the sum of the core power plus the power dissipated in the load(s). The following is the power dissipation for $V_{DD} = 3.3V + 5\% = 3.465V$, which gives worst case results.

NOTE: Please refer to Section 3 for details on calculating power dissipated in the load.

- Power (core)_{MAX} = $V_{DD_MAX} * (I_{DD_MAX} + I_{DDA_MAX}) = 3.465V * (137mA + 17mA) = 533.6mW$
- Power (outputs)_{MAX} = **32.8mW/Loaded Output pair**

Total Power_{MAX} (3.465V, with all outputs switching) = 533.6mW + 32.8mW = **566.4mW**

2. Junction Temperature.

Junction temperature, T_j , is the temperature at the junction of the bond wire and bond pad and directly affects the reliability of the device. The maximum recommended junction temperature for is 125°C.

The equation for T_j is as follows: $T_j = \theta_{JA} * Pd_total + T_A$

T_j = Junction Temperature

θ_{JA} = Junction-to-Ambient Thermal Resistance

Pd_total = Total Device Power Dissipation (example calculation is in section 1 above)

T_A = Ambient Temperature

In order to calculate junction temperature, the appropriate junction-to-ambient thermal resistance θ_{JA} must be used. Assuming a moderate air flow of 200 linear feet per minute and a multi-layer board, the appropriate value is 39.7°C/W per [Table 7](#) below.

Therefore, T_j for an ambient temperature of 70°C with all outputs switching is:

$$70^\circ\text{C} + 0.566\text{W} * 39.7^\circ\text{C/W} = 111^\circ\text{C}. \text{ This is below the limit of } 125^\circ\text{C}.$$

This calculation is only an example. T_j will obviously vary depending on the number of loaded outputs, supply voltage, air flow and the type of board (single layer or multi-layer).

Table 7. Thermal Resistance θ_{JA} for 20-Lead SOIC, Forced Convection¹

θ_{JA} vs. Air Flow			
Linear Feet per Minute	0	200	500
Single-Layer PCB, JEDEC Standard Test Boards	83.2°C/W	65.7°C/W	57.5°C/W
Multi-Layer PCB, JEDEC Standard Test Boards	46.2°C/W	39.7°C/W	36.8°C/W

NOTE 1. Most modern PCB designs use multi-layered boards. The data in the second row pertains to most designs.

3. Calculations and Equations.

The purpose of this section is to derive the power dissipated into the load.

HSTL output driver circuit and termination are shown in [Figure 4](#).

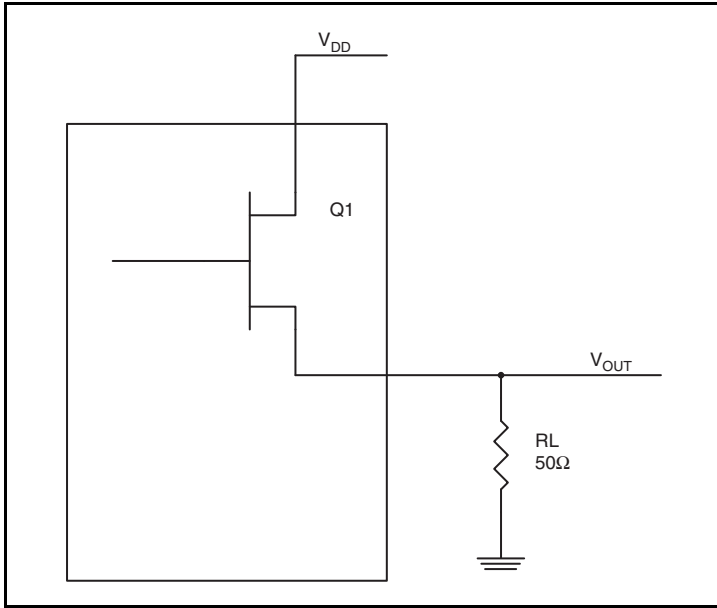

Figure 4. HSTL Driver Circuit and Termination

To calculate worst case power dissipation into the load, use the following equations which assume a 50Ω load.

Pd_H is power dissipation when the output drives high.

Pd_L is the power dissipation when the output drives low.

$$Pd_H = (V_{OH_MAX} / R_L) * (V_{DDO_MAX} - V_{OH_MAX})$$

$$Pd_L = (V_{OL_MAX} / R_L) * (V_{DDO_MAX} - V_{OL_MAX})$$

$$Pd_H = (1.0V / 50\Omega) * (2V - 1.0V) = \mathbf{20mW}$$

$$Pd_L = (0.4V / 50\Omega) * (2V - 0.4V) = \mathbf{12.8mW}$$

$$\text{Total Power Dissipation per output pair} = Pd_H + Pd_L = \mathbf{32.8mW}$$

Reliability Information

Table 8. θ_{JA} vs. Air Flow Table for a 20-Lead TSSOP¹

θ_{JA} vs. Air Flow			
Linear Feet per Minute	0	200	500
Single-Layer PCB, JEDEC Standard Test Boards	83.2°C/W	65.7°C/W	57.5°C/W
Multi-Layer PCB, JEDEC Standard Test Boards	46.2°C/W	39.7°C/W	36.8°C/W

NOTE 1. Most modern PCB designs use multi-layered boards. The data in the second row pertains to most designs.

Transistor Count

The transistor count for 8725B-21 is: 2969

Package Outline and Package Dimensions

Package Outline - M Suffix for 20-Lead SOIC

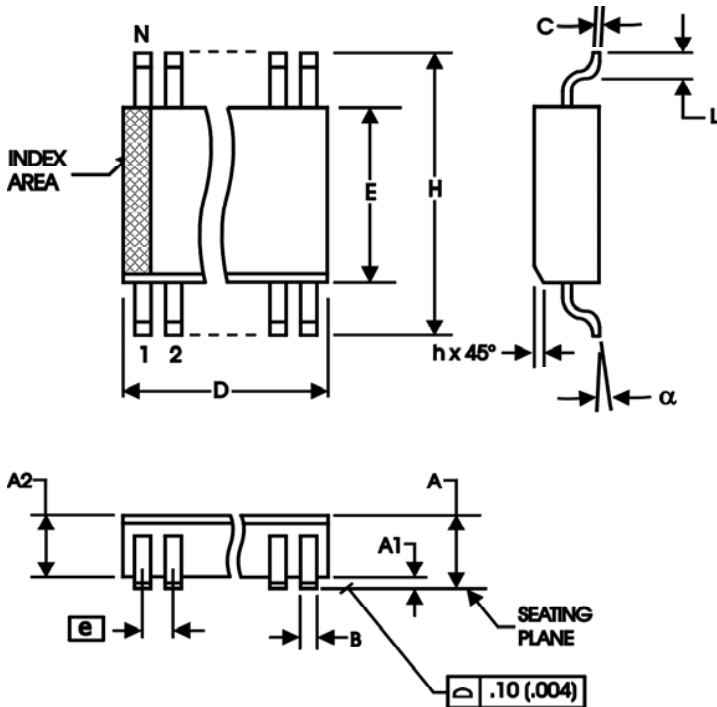

Table 9. Package Dimensions for 20-Lead SOIC

300 Millimeters All Dimensions in Millimeters		
Symbol	Minimum	Maximum
N	20	
A		2.65
A1	0.10	
A2	2.05	2.55
B	0.33	0.51
C	0.18	0.32
D	12.60	13.00
E	7.40	7.60
e	1.27 Basic	
H	10.00	10.65
h	0.25	0.75
L	0.40	1.27
a	0°	8°

Reference Document: JEDEC Publication 95, MS-013, MS-119

Ordering Information

Table 10. Ordering Information

Part/Order Number	Marking	Package	Shipping Packaging	Temperature
ICS8725BM-21LF	ICS8725BM-21LF	20-Lead SOIC, Lead-Free	Tube	0°C to 70°C
ICS8725BM-21LFT	ICS8725BM-21LF	20-Lead SOIC, Lead-Free	Tape & Reel	0°C to 70°C

IMPORTANT NOTICE AND DISCLAIMER

RENESAS ELECTRONICS CORPORATION AND ITS SUBSIDIARIES (“RENESAS”) PROVIDES TECHNICAL SPECIFICATIONS AND RELIABILITY DATA (INCLUDING DATASHEETS), DESIGN RESOURCES (INCLUDING REFERENCE DESIGNS), APPLICATION OR OTHER DESIGN ADVICE, WEB TOOLS, SAFETY INFORMATION, AND OTHER RESOURCES “AS IS” AND WITH ALL FAULTS, AND DISCLAIMS ALL WARRANTIES, EXPRESS OR IMPLIED, INCLUDING, WITHOUT LIMITATION, ANY IMPLIED WARRANTIES OF MERCHANTABILITY, FITNESS FOR A PARTICULAR PURPOSE, OR NON-INFRINGEMENT OF THIRD-PARTY INTELLECTUAL PROPERTY RIGHTS.

These resources are intended for developers who are designing with Renesas products. You are solely responsible for (1) selecting the appropriate products for your application, (2) designing, validating, and testing your application, and (3) ensuring your application meets applicable standards, and any other safety, security, or other requirements. These resources are subject to change without notice. Renesas grants you permission to use these resources only to develop an application that uses Renesas products. Other reproduction or use of these resources is strictly prohibited. No license is granted to any other Renesas intellectual property or to any third-party intellectual property. Renesas disclaims responsibility for, and you will fully indemnify Renesas and its representatives against, any claims, damages, costs, losses, or liabilities arising from your use of these resources. Renesas' products are provided only subject to Renesas' Terms and Conditions of Sale or other applicable terms agreed to in writing. No use of any Renesas resources expands or otherwise alters any applicable warranties or warranty disclaimers for these products.

(Disclaimer Rev.1.01 Jan 2024)

Corporate Headquarters

TOYOSU FORESIA, 3-2-24 Toyosu,
Koto-ku, Tokyo 135-0061, Japan
www.renesas.com

Trademarks

Renesas and the Renesas logo are trademarks of Renesas Electronics Corporation. All trademarks and registered trademarks are the property of their respective owners.

Contact Information

For further information on a product, technology, the most up-to-date version of a document, or your nearest sales office, please visit www.renesas.com/contact-us/.