

Description

The 8V19N492-39 is a fully integrated FemtoClock NG jitter attenuator and clock synthesizer. The device is designed as a high-performance clock solution for conditioning and frequency/phase management of wireless base station radio equipment boards. The device is optimized to deliver excellent phase noise performance as required in GSM, WCDMA, LTE, and LTE-A radio board implementations. The 8V19N492-39 supports JESD204B subclass 0 and 1 clocks.

A two-stage PLL architecture supports both jitter attenuation and frequency multiplication. The first stage PLL is the jitter attenuator and uses an external VCXO for best possible phase noise characteristics. The second stage PLL locks on the VCXO-PLL output signal and synthesizes the target frequency.

The 8V19N492-39 supports the clock generation of high-frequency clocks from the selected VCO and low-frequency synchronization signals (SYSREF). SYSREF signals are internally synchronized to the clock signals. Delay functions exist for achieving alignment and controlled phase delay between system reference and clock signals and to align/delay individual output signals. The two redundant inputs are monitored for activity. Four selectable clock switching modes are provided to handle clock input failure scenarios. Auto-lock, individually programmable output frequency dividers and phase adjustment capabilities are added for flexibility.

The device is configured through a 3/4-wire SPI interface and reports lock and signal loss status in internal registers and via a lock detect (LOCK) output. Internal status bit changes can also be reported via the nINT output.

The 8V19N492-39 is ideal for driving converter circuits in wireless infrastructure, radar/imaging, and instrumentation/medical applications. The device is a member of the high-performance clock family from Renesas.

Typical Applications

- Wireless infrastructure applications: GSM, WCDMA, LTE, LTE-A
- Ideal clock driver for jitter-sensitive ADC and DAC circuits
- Low phase noise clock generation
- Ethernet line cards
- Radar and imaging
- Instrumentation and medical

Features

- High-performance clock RF-PLL with support for JESD204B
- Optimized for low phase noise: -150.5dBc/Hz (800kHz offset; 245.76MHz clock)
- Integrated phase noise of 46fs RMS typical (12kHz-20MHz).
- Dual-PLL architecture
- First PLL stage with external VCXO for clock jitter attenuation
- Second PLL with internal FemtoClock NG PLL: 3932.16MHz
- Six output channels with a total of 16 outputs, organized in:
 - Four JESD204B channels (device clock and SYSREF output) with two, four, and five outputs
 - One clock channel with two outputs
 - One VCXO output
- Configurable integer clock frequency dividers
- Supported clock output frequencies include: 3932.16, 1966.08, 983.04, 491.52, 245.76, 122.88, 61.44, and 30.72MHz
- Low-power LVPECL/LVDS outputs support configurable signal amplitude, DC and AC coupling, and LVPECL, LVDS line terminations techniques
- Phase delay circuits
 - Clock phase delay with 256 steps of 254ps and a range of 0 to 62.02ns
 - Individual SYSREF phase delay with 8 steps of 255ps
 - Additional individual SYSREF fine phase delay with 25ps steps
 - Global SYSREF signal delay with 256 steps of 509ps and a range of 0 to 129.7ns
- Redundant input clock architecture with two inputs including:
 - Input activity monitoring
 - Manual and automatic, fault-triggered clock selection modes
 - Priority controlled clock selection
 - Digital holdover and hitless switching
 - Differential inputs accept LVDS and LVPECL signals
- SYSREF generation modes include internal and external trigger mode for JESD204B
- Supply voltage: 3.3V
- SPI Interface, 3/4 wire configurable
- SPI and control I/O voltage: 1.8V/3.3V (configurable)
- Package: 10 × 10 mm 88-VFQFPN
- Temperature range: -40°C to +85°C

Contents

Description	1
Typical Applications	1
Features	1
Pin Assignment	5
Pin Descriptions	6
Principles of Operation	8
Overview	8
Phase-Locked Loop Operation	9
Frequency Generation	9
VCXO-PLL	10
FemtoClock NG PLL	11
Channel Frequency Divider	12
Redundant Inputs	13
Monitoring and LOS of Input Signal	13
Input Re-Validation	13
Clock Selection	14
Holdover	14
Input Priorities	14
Hold-off Counter	15
Revertive Switching	15
Short-Term Holdover	15
Automatic with Holdover (nM/A[1:0] = 11)	15
VCXO-PLL Lock Detect (LOLV)	16
FemtoClock NG Loss-of-Lock (LOLF)	17
Channel, Output, and JESD204B Logic	18
Channel	18
Differential Outputs	18
Output Phase Delay	21
Configuration for JESD204B Operation	21
Synchronizing SYSREF and Clock Output Dividers	21
SYSREF Generation	21
Internal SYSREF Generation	22
External SYSREF Generation	22
QCLK to QREF (SYSREF) Phase Alignment	23
Deterministic Phase Relationship and Phase Alignment	24
Status Conditions and Interrupts	24
Device Startup, Reset and Synchronization	25
Recommended Configuration Sequence	25
Changing Frequency Dividers and Phase Delay Values	26
SPI Interface	27
Configuration Registers	30
Channel and Clock Output Registers	33
QREF Output State Registers	36
PLL Frequency Divider Registers	38
VCXO-PLL Control Registers	41
Input Selection Mode Registers	44
SYSREF, QCLK_V Modification Control Registers	47
Status Registers	50

General Control Registers	53
Electrical Characteristics	54
Absolute Maximum Ratings	54
Pin Characteristics	54
DC Characteristics	55
AC Characteristics	58
Clock Phase Noise Characteristics	64
Application Information	66
Termination for QCLK_y, QREF_r LVDS Outputs (STYLE = 0)	66
AC Termination for QCLK_y, QREF_r LVDS Outputs (STYLE = 0)	66
Termination for QCLK_y, QREF_r LVPECL Outputs (STYLE = 1)	67
Thermal Characteristics	67
Case Temperature Considerations	68
Package Outline Drawings	69
Ordering Information	69
Marking Diagram	69
Glossary	69
Revision History	70

Block Diagram

Figure 1. Block Diagram ($f_{VCO} = 3932.16\text{MHz}$)

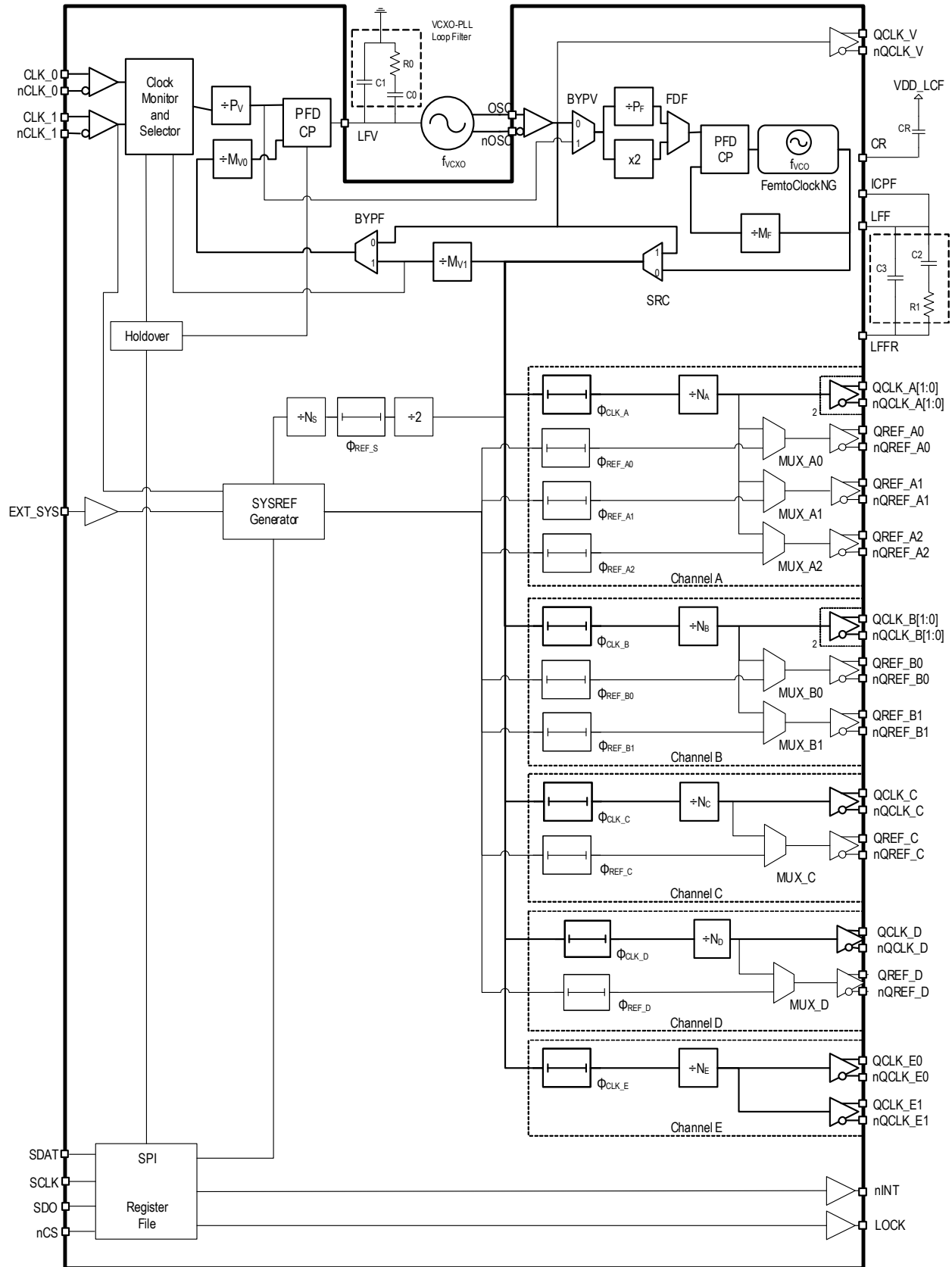

Pin Assignment

Figure 2. Pinout for 10 × 10 mm 88-VFQFPN Package with Exposed Pad (Top View)

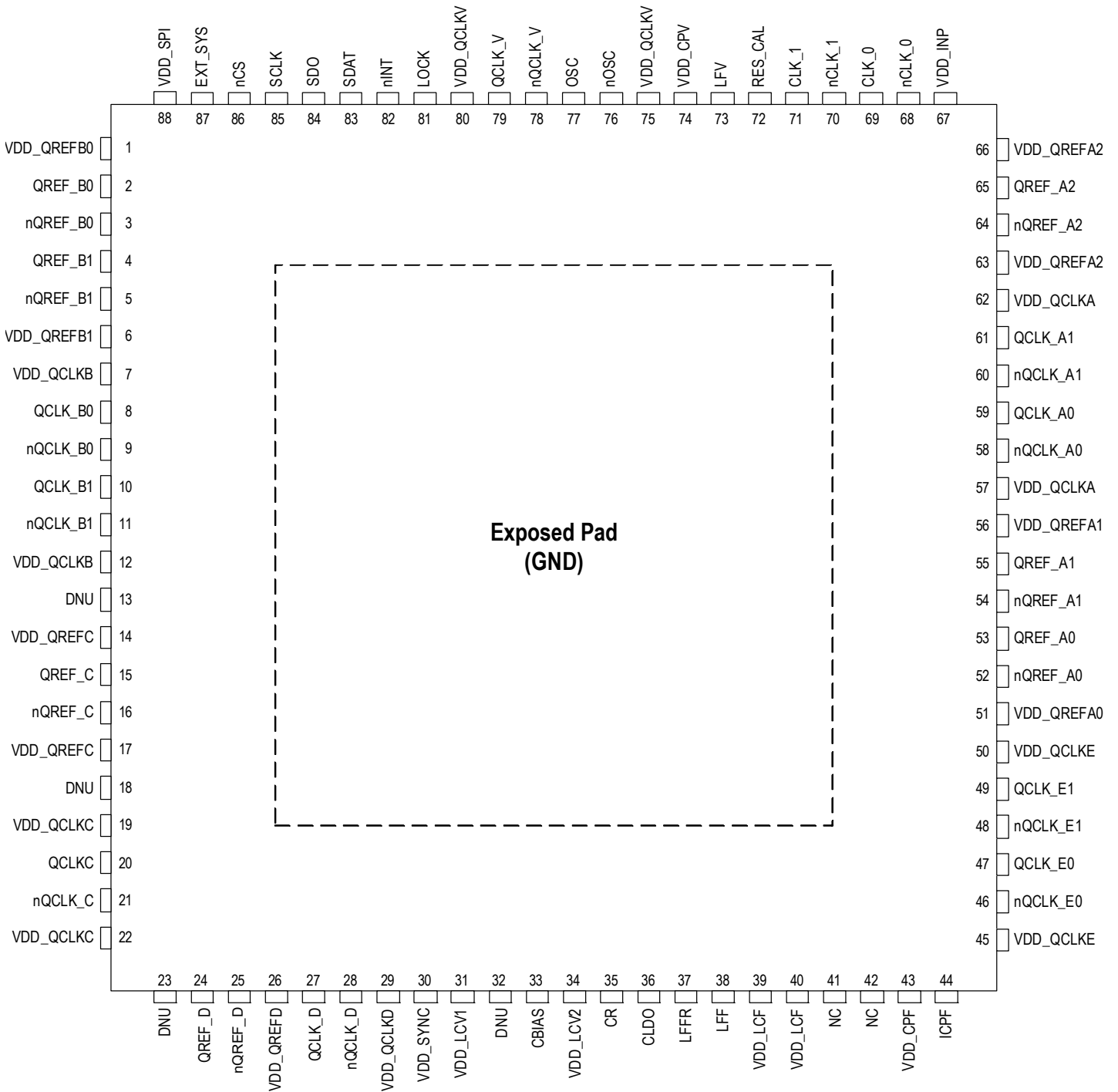

Pin Descriptions

Table 1. Pin Descriptions [a]

Pin	Name	Type ^[b]		Description
69	CLK_0	Input	PD	Device clock 0 non-inverting and inverting differential clock input. Inverting input is biased to $V_{DD_V}/2$ by default when left floating. Compatible with LVPECL, LVDS and LVCMOS signals.
68	nCLK_0		PD/PU	
71	CLK_1	Input	PD	Device clock 1 non-inverting and inverting differential clock input. Inverting input is biased to $V_{DD_V}/2$ by default when left floating. Compatible with LVPECL, LVDS and LVCMOS signals.
70	nCLK_1		PD/PU	
59, 58	QCLK_A0, nQCLK_A0	Output		Differential clock output A0 (Channel A). Configurable LVPECL/LVDS style and amplitude.
61, 60	QCLK_A1, nQCLK_A1	Output		Differential clock output A1 (Channel A). Configurable LVPECL/LVDS style and amplitude.
53, 52	QREF_A0, nQREF_A0	Output		Differential SYSREF/clock output REF_A0 (Channel A). LVDS style for SYSREF operation, configurable LVPECL/LVDS style and amplitude for clock operation.
55, 54	QREF_A1, nQREF_A1	Output		Differential SYSREF/clock output REF_A1 (Channel A). LVDS style for SYSREF operation, configurable LVPECL/LVDS style and amplitude for clock operation.
65, 64	QREF_A2, nQREF_A2	Output		Differential SYSREF/clock output REF_A2 (Channel A). LVDS style for SYSREF operation, configurable LVPECL/LVDS style and amplitude for clock operation.
8, 9	QCLK_B0, nQCLK_B0	Output		Differential clock output B0 (Channel B). Configurable LVPECL/LVDS style and amplitude.
10, 11	QCLK_B1, nQCLK_B1	Output		Differential clock output B1 (Channel B). Configurable LVPECL/LVDS style and amplitude.
2, 3	QREF_B0, nQREF_B0	Output		Differential SYSREF/clock output REF_B0 (Channel B). LVDS style for SYSREF operation, configurable LVPECL/LVDS style and amplitude for clock operation.
4, 5	QREF_B1, nQREF_B1	Output		Differential SYSREF/clock output REF_B1 (Channel B). LVDS style for SYSREF operation, configurable LVPECL/LVDS style and amplitude for clock operation.
20, 21	QCLK_C, nQCLK_C	Output		Differential clock output C (Channel C). Configurable LVPECL/LVDS style and amplitude.
15, 16	QREF_C, nQREF_C	Output		Differential SYSREF/clock output REF_C (Channel C). LVDS style for SYSREF operation, configurable LVPECL/LVDS style and amplitude for clock operation.
27, 28	QCLK_D, nQCLK_D	Output		Differential clock output D (Channel D). Configurable LVPECL/LVDS style and amplitude.
24, 25	QREF_D, nQREF_D	Output		Differential SYSREF/clock output REF_D (Channel D). LVDS style for SYSREF operation, configurable LVPECL/LVDS style and amplitude for clock operation.
47, 46	QCLK_E0, nQCLK_E0	Output		Differential clock output E0. Configurable LVPECL/LVDS style and amplitude.
49, 48	QCLK_E1, nQCLK_E1	Output		Differential clock output E1. Configurable LVPECL/LVDS style and amplitude.
79, 78	QCLK_V, nQCLK_V	Output		Differential VCXO-PLL clock outputs. Configurable LVPECL/LVDS style and amplitude.

Table 1. Pin Descriptions (Cont.)^[a]

Pin	Name	Type ^[b]		Description
82	nINT	Output		Status output pin for signaling internal changed conditions. 1.8V LVCMOS interface levels.
81	LOCK	Output		PLL lock detect status output for both PLLs. 1.8V LVCMOS interface levels.
87	EXT_SYS	Input	PD	External SYSREF pulse trigger input. 1.8V LVCMOS interface levels.
83	SDAT	Input/ Output	PU	Serial Control Port SPI Data Input/Output. Selectable 1.8V/3.3V LVCMOS Interface levels. 3.3V tolerant when set to 1.8V input.
85	SCLK	Input	PD	Serial Control Port SPI Clock Input. Selectable 1.8V/3.3V LVCMOS Interface levels. 3.3V tolerant when set to 1.8V.
86	nCS	Input	PU	Serial Control Port SPI Chip Select Input. Register-selectable 1.8V/3.3V LVCMOS interface levels. 3.3V tolerant when set to 1.8V.
84	SDO	Output		Serial Control Port SPI Mode Data Output (4-wire mode). Pin is not used in SPI 3-wire mode. Register-selectable 1.8V/3.3V LVCMOS interface levels.
35	CR	Analog		Internal VCO regulator bypass capacitor. Use a 1.0 μ F capacitor between the CR and VDD_LCF.
33	CBIAS	Analog		Internal bias circuit for VCO. Connect a 4.7 μ F capacitor to GND.
36	CLDO	Analog		Internal LDO bypass for VCO. Connect a 10 μ F capacitor to GND.
73	LFV	Output		VCXO-PLL charge pump output. Connect to the loop filter for the external VCXO.
77	OSC	Input	PD	VCXO non-inverting and inverting differential clock input. Inverting input is biased to $V_{DD_V}/2$ by default when left floating. Compatible with LVPECL, LVDS and LVCMOS signals.
76	nOSC		PD/PU	
44	ICPF	Analog		Connect to LFF pin (38) and external loop filter.
38	LFF	Output		Loop filter/charge pump output for the FemtoClockNG PLL. Connect to the external loop filter.
37	LFFR	Analog		Ground return path pin for the VCO loop filter.
72	RES_CAL	Analog		Connect a 2.8 k Ω (1%) resistor to GND for output current calibration.
13, 18, 23, 32, 41, 42	DNU			Do not use, do not connect.
57, 62	VDD_QCLKA	Power		Positive supply voltage (3.3V) for the QCLK_A[1:0] outputs.
51	VDD_QREFA0	Power		Positive supply voltage (3.3V) for the QREF_A0 outputs.
56	VDD_QREFA1	Power		Positive supply voltage (3.3V) for the QREF_A1 outputs.
63, 66	VDD_QREFA2	Power		Positive supply voltage (3.3V) for the QREF_A2 outputs.
7, 12	VDD_QCLKB	Power		Positive supply voltage (3.3V) for the QCLK_B[1:0] outputs.
1	VDD_QREFB0	Power		Positive supply voltage (3.3V) for the QREF_B0 output.
6	VDD_QREFB1	Power		Positive supply voltage (3.3V) for the QREF_B1 output.
19, 22	VDD_QCLKC	Power		Positive supply voltage (3.3V) for the QCLK_C outputs.
14, 17	VDD_QREFC	Power		Positive supply voltage (3.3V) for the QREF_C outputs.
29	VDD_QCLKD	Power		Positive supply voltage (3.3V) for the QCLK_D outputs.
26	VDD_QREFD	Power		Positive supply voltage (3.3V) for the QREF_D outputs.
45, 50	VDD_QCLKE	Power		Positive supply voltage (3.3V) for the QCLK_E[1:0] outputs.

Table 1. Pin Descriptions (Cont.)^[a]

Pin	Name	Type ^[b]	Description
88	VDD_SPI	Power	Positive supply voltage (3.3V) for the SPI interface.
67	VDD_INP	Power	Positive supply voltage (3.3V) for the differential inputs (CLK0 to CLK1).
31	VDD_LCV1	Power	Positive supply voltage (3.3V) for internal VCXO_PLL circuits.
34	VDD_LCV2	Power	Positive supply voltage (3.3V) for internal VCXO_PLL circuits.
39,40	VDD_LCF	Power	Positive supply voltage (3.3V) for the internal oscillator of the FemtoClockNG PLL.
43	VDD_CPF	Power	Positive supply voltage (3.3V) for internal FemtoClockNG circuits.
75, 80	VDD_QCLKV	Power	Positive supply voltage (3.3V) for OSC, nOSC input and QCLKV, nQCLKV output.
74	VDD_CPV	Power	Positive supply voltage (3.3V) for internal VCXO_PLL circuits.
30	VDD_SYNC	Power	Positive supply voltage (3.3V).
Exposed Pad (EP)	GND	Power	Ground supply voltage (GND) and ground return path. Connect to board GND (0V).

[a] See [Application Information](#) for essential information on power supply filtering.

[b] PU (pull-up) and PD (pull-down) indicate internal input resistors. See [Figure 47](#) for values.

Principles of Operation

Overview

The 8V19N492-39 generates low-phase noise, synchronized clock and SYSREF output signals locked to an input reference frequency. The device contains two PLLs with configurable frequency dividers. The first PLL (VCXO-PLL, suffix V) uses an external VCXO as the oscillator and provides jitter attenuation. The external loop filter is used to set the VCXO-PLL bandwidth frequency in conjunction with internal parameters. The second, low-phase noise PLL (FemtoClock NG, suffix F) multiplies the VCXO-PLL frequency to 3932.16MHz. The FemtoClock NG PLL is completely internal and provides a central timing reference point for all output signals. From this point, fully synchronous dividers generate the output frequencies and the internal timing references for JESD204B support. The device supports the generation of SYSREF pulses asynchronous to the clock signals.

There are five channels consisting of clock and/or SYSREF outputs. The clock outputs are configurable with support for LVPECL or LVDS formats and a variable output amplitude. Clock and SYSREF offer adjustable phase delay functionality. Individual output channels and unused circuit blocks support user-configurable powered-down states for operating with lower power consumption. The register map, accessible through SPI interface with read-back capability controls the main device settings and delivers device status information. For redundancy purpose, there are four selectable reference frequency inputs and a configurable switch logic with priority-controlled auto-selection and holdover support.

Phase-Locked Loop Operation

Frequency Generation

Table 2 displays the available frequency dividers for clock generation. The dividers must be set by the user to match input, VCXO and VCO frequency to achieve frequency and phase lock on both PLLs. The frequency of the external VCXO is selected by the user, the internal VCO frequency is set to 3932.16MHz. Table 3 shows example divider configurations for typical wireless infrastructure applications.

Table 2. PLL Operation and Divider Values

Divider	Range	Operation for $f_{VCO} = 2457.6\text{MHz}$			Frequency Synthesis (FemtoClock NG Bypassed)
		Jitter Attenuation, Dual-PLL with deterministic Input-to-Output Delay	Jitter Attenuation, Dual-PLL	Frequency Synthesis (VCXO-PLL Bypassed)	
SRC	0, 1	0	0	0	1
BYPV	0, 1	0	0	1	0
BYPF	0, 1	1	0	X	X
VCXO-PLL Pre-Divider P_V	$\div 1 \dots \div 4095$: (12 bit)	Input clock frequency $f_{CLK} = P_V \cdot \frac{f_{VCXO}}{P_F} \cdot \frac{M_F}{M_{V0} \cdot M_{V1}}$	Input clock frequency $f_{CLK} = f_{VCXO} \cdot \frac{P_V}{M_{V0}}$ M_{V1} setting is not applicable to PLL operation	Input clock frequency $f_{CLK} = f_{VCO} \cdot \frac{P_V \cdot P_F}{M_F}$ M_{V0} and M_{V1} settings are not applicable to the PLL operation. P_F : Set P_F to 0.5 in above equation if the frequency doubler is engaged by setting $FDF = 1$	Input frequency $f_{CLK} = f_{VCXO} \cdot \frac{P_V}{M_{V0}}$ M_{V1} , P_F and M_F settings are not applicable to VCXO-PLL operation
VCXO-PLL Feedback Divider M_{V0}	$\div 1 \dots \div 4095$: (12 bit)				
PLL Feedback Divider ^[a] M_{V1}	$\div 4 \dots \div 511$: (9 bit)				
FemtoClock NG Pre-Divider P_F	$\div 1 \dots \div 63$: (6 bit)	VCXO frequency: $f_{VCXO} = f_{VCO} \cdot \frac{P_F}{M_F}$			
FemtoClock NG Feedback Dividers M_F	$\div 8 \dots \div 511$ (9 bit)	P_F : Set P_F to 0.5 in above equation if the frequency doubler is engaged by setting $FDF = 1$			
Output Divider N_x (x=A, B, C, D, E)	$\div 1 \dots \div 200$:	Output frequency $f_{OUT} = \frac{f_{VCO}}{N_x}$			Output frequency $f_{OUT} = \frac{f_{VCXO}}{N_x}$
SYSREF Divider ^[b] N_S	$\div 64 \dots \div 12,800$: $2 \times \{2, 4, 8, 16\} \times \{2, 3, 4, 5\} \times \{2, 4\} \times \{2, 4\} \times \{2, 3, 4, 5\}$	SYSREF frequency/rate $f_{SYSREF} = \frac{f_{VCO}}{2N_S}$			SYSREF frequency/rate $f_{SYSREF} = \frac{f_{VCXO}}{2N_S}$

[a] For input monitoring, configure M_{V1} as described in [Monitoring and LOS of Input Signal](#).

[b] For SYSREF operation, configure $SYNC[5:0]$ as described in [Status Conditions and Interrupts](#).

VCXO-PLL

The prescaler P_V and the VCXO-PLLs feedback divider M_{V0} and M_{V1} require configuration to match the input frequency to the VCXO-frequency. The BYPF setting allows to route the VCXO-PLLs feedback path through the M_{V0} divider. Alternatively, the feedback path is routed through the second PLL and both the M_{V0} and M_{V1} feedback divider. M_{V0} has a divider value range of 12 bit; M_{V1} has 9 bit. The feedback path through the second PLL, in combination with the divider setting $P_F = \div 1$, is the preferred setting for achieving deterministic delay from the clock input to the outputs. Multiple divider settings are available to enable support for input frequencies of e.g. 245.76, 122.88, 61.44 and 30.72MHz and the VCXO-frequencies of 122.88MHz, 61.44, 38.4, 30.72 and 245.76MHz.

In addition, the range of available input and feedback dividers allows to adjust the phase detector frequency independent on the input and VCXO frequencies. In general, the phase detector may be set into the range from 120kHz to the input reference frequency. The VCXO-PLL charge pump current is controllable via a register and can be set in 50µA steps from 50µA to 1.6mA. The VCXO-PLL may be bypassed: the FemtoClock NG PLL locks to the pre-divider input frequency.

Table 3. Example Configurations for $f_{VCXO} = 122.88\text{MHz}^{[a]}$

Input Frequency (MHz)	VCXO-PLL Divider Settings		f_{PFD} (MHz)
	P_V	M_{V0}	
245.76	2	1	122.88
	32	16	7.68
	256	128	0.96
	2048	1024	0.12
122.88	1	1	122.88
	16	16	7.68
	128	128	0.96
	1024	1024	0.12

[a] BYPF = 0

Table 4. Example Configurations for $f_{VCXO} = 38.4\text{MHz}^{[a]}$

Input Frequency (MHz)	VCXO- PLL Divider Settings		f_{PFD} (MHz)
	P_V	M_{V0}	
245.76	32	5	7.68
	128	20	1.92
	512	80	0.48
	2048	320	0.12
122.88	16	5	7.68
	64	20	1.92
	256	80	0.48
	1048	320	0.12

[a] BYPF = 0

Table 5. VCXO-PLL Bypass Settings

BYPV	Operation
0	VCXO-PLL operation.
1	VCXO-PLL bypassed and disabled. The reference clock for the FemtoClock NG PLL is the input clock divided by the pre-divider P_V . The input clock selection must be set to manual by the user. Clock switching and holdover are not defined. Device will not attenuate input jitter. No external VCXO component and loop filter required.

Table 6. PLL Feedback Path Settings

BYPF	Operation ^[a]
0	VCXO-PLL feedback path through the M_{V0} divider. FemtoClock NG feedback path uses the M_F divider.
1	VCXO-PLL feedback path through the $M_{V1} \times M_{V0}$ dividers. FemtoClock NG feedback path uses the M_F divider. Preferred setting for achieving deterministic delay from input to the outputs.

[a] Regardless of the selected internal feedback path, the M_{V1} divider should be set to match its internal output frequency to the input reference frequency: the M_{V1} output signal is the internal reference for input loss-of-signal detect.

FemtoClock NG PLL

This PLL locks to the output signal of the VCXO-PLL ($BYPV = 0$). It requires configuration of the frequency doubler FDF or the pre-divider PF and the feedback divider MF to match the VCXO-PLL frequency to the VCO frequency of 3932.16MHz. This PLL is internally configured to high-bandwidth. Best phase noise is typically achieved by engaging the internal frequency doubler ($FDF = 1$). If engaged, the signal from the first PLL stage is doubled in frequency, increasing the phase detector frequency of the FemtoClock NG PLL. Enabling the frequency doubler disables the frequency pre-divider PF. If the frequency doubler is not used ($FDF = 0$), the PF pre-divider has to be configured. Typically PF is set to $\div 1$ to keep the phase detector frequency as high as possible. Set PF to other divider values to achieve specific frequency ratios (1 to 19.2, 1 to 76.8, etc.) between first and second PLL stage .

Table 7. Frequency Doubler

FDF	Operation
0	Frequency doubler off. PF divides clock signal from VCXO-PLL or input (in bypass)
1	Frequency doubler on. Signal from VCXO-PLL or input (in bypass) is doubled in frequency. PF divider has no effect.

Table 8. Output Divider Source Signal

SRC	Operation
0	The output divider input signal is the FemtoClock NG PLL.
1	The output divider input signal is the VCXO-PLL output signal. The FemtoClock NG PLL is bypassed.

Table 9. Example PLL Configurations

VCXO-Frequency (MHz)	FemtoClock NG Divider Settings				Output Frequency (MHz)
	FD	PF	MF	Nx ^[a]	
122.88	x2	–	16	1	3932.16
122.88	–	1	32	2	1966.08
				4	983.04
				8	491.52
				16	245.76
				32	122.88
				64	61.44
				128	30.72

[a] x = A to E

Channel Frequency Divider

The device supports five independent channels A to E. Each channel has a frequency divider Nx (x = A to E) that divides the VCO frequency to the output frequency. Each divider be individually set to a value in the range of ÷1 to ÷200. See [Table 10](#) for typical divider values and [Table 31](#) for the complete set of supported divider values

Table 10. Integer Frequency Divider Settings

Channel Divider Nx ^[a]	Output Clock Frequency (MHz)
	f _{VCO} = 3932.16MHz
÷1	3932.16
÷2	1966.08
÷3	1310.72
÷4	983.04
÷5	786.432
÷6	655.36
÷8	491.52
÷10	393.216
÷12	327.68
÷15	262.144
÷16	245.76
÷18	218.4533
÷20	196.608
÷24	163.84
÷30	131.072
÷32	122.88
÷36	109.2266
÷40	98.304

Table 10. Integer Frequency Divider Settings (Cont.)

Channel Divider Nx ^[a]	Output Clock Frequency (MHz)
	$f_{VCO} = 3932.16\text{MHz}$
÷48	81.92
÷50	78.6432
÷60	65.536
÷64	61.44
÷72	54.6133
÷80	49.152
÷96	40.96
÷100	36.864
÷120	32.768
÷128	30.72
÷150	26.2144
÷160	24.576
÷200	19.6608

[a] x = A to E

Redundant Inputs

The two inputs are compatible with LVDS, LVPECL and single-ended LVCMOS signal formats. See [Application Information](#) for applicable input interface circuits.

Monitoring and LOS of Input Signal

The two inputs of the device are individually monitored for activity. Inactivity is defined by a static input signal.

The clock input monitors compare the device input frequency (f_{CLK}) to the frequency of the VCO divided by M_{V1} (regardless of the internal feedback path using or not using M_{V1}). A clock input is declared invalid with the corresponding LOS (Loss-of-input-signal) indicator bit set after three consecutive missing clock edges. For correct operation of the LOS detect circuit, M_{V1} must be powered-on by setting PD_MV1 = 0. The MV1 divider must be set so that the LOS detect reference frequency matches the input frequency. For instance, if the input frequency is 245.76MHz, M_{V1} should be set to ÷16: The VCO frequency of 3932.16MHz divided by 16 equals the input frequency of 245.76MHz. For an input frequency of 122.88MHz, set M_{V1} to ÷32 etc. Failure to set M_{V1} to match the input frequency will result in added latency to the LOS circuit (if $f_{VCO} \div M_{V1} < f_{CLK}$) or false LOS indication (if $f_{VCO} \div M_{V1} > f_{CLK}$).

The minimum frequency that the circuit can monitor is: $f_{VCO} / M_{V1(MAX)} = 7.708\text{MHz}$. In applications with an input frequency lower than 7.708MHz, disable the monitor to trigger the status flags by setting BLOCK_LOR = 1.

If differential input signals are applied, the input will also detect an LOS condition in case of a zero differential input voltage.

Input Re-Validation

A clock input is declared valid and the corresponding LOS status bit is reset after the clock input signal returns for user-configurable number of consecutive input periods. This re-validation of the selected input clock is controlled by the CNTV setting (verification pulse counter).

Clock Selection

The device supports four input selection modes: manual, short-term holdover and two automatic switch modes. The modes are described in the following table:

Table 11. Clock Selection Settings

Mode	Description	Application
Manual nM/A[1:0] = 00	Input selection follows user-configuration of SEL[1:0]. Selection is <i>never</i> changed by the internal state machine. A failing reference clock will cause an LOS event and the PLL will unlock if the failing clock is selected. Re-validation of the selected input clock will result in the PLL to re-lock on that input clock.	Startup and external selection control
Automatic nM/A[1:0] = 01	Input selection follows LOS status by user preset input switch priorities. A failing input clock will cause an LOS event for that clock input. If the selected clock has an LOS event, the device will immediately initiate a clock fail-over switch. The switch target is determined by pre-set input priorities. No valid clock scenario: If no valid input clocks exist, the device will not attempt to switch and will not enter the holdover state. The PLL is not locked. Re-validation of any input clock that is not the selected clock will result in the PLL to attempt to lock on that input clock. For more information, see Revertive Switching .	Multiple inputs with qualified clock signals
Short-term Holdover nM/A[1:0] = 10	Input selection follows user-configuration of SEL[1:0]. Selection is never changed by the internal state machine. A failing reference clock will cause an LOS event. If the selected reference fails, the device will enter holdover <i>immediately</i> . Re-validation of the selected input clock is controlled by the CNTV setting. A successful re-validation will result in the PLL to re-lock on that input clock. For more information, see Short-Term Holdover .	Single reference
Automatic with holdover nM/A[1:0] = 11	Input selection follows LOS status by user preset input priorities. Each failing input clock will cause an LOS event for that clock input. If the <i>selected</i> clock detects an LOS event, the device will go into holdover and the hold-off down-counter (CNTH) starts. The device initiates a clock fail-over switch <i>after</i> expiration of the hold-off counter. The switch target is determined by the preset input priorities. No valid clock scenario: If no valid input clocks exist, the device will not attempt to switch and will remain in the holdover state. Re-validation of any input clock will result in the PLL to attempt to lock on that input clock. For more information, see Automatic with Holdover (nM/A[1:0] = 11) and Revertive Switching .	Multiple inputs

Holdover

In holdover state, the output frequency and phase is derived from an internal, digital value based on previous frequency and phase information. Holdover characteristics are defined in [Table 54](#).

Input Priorities

Configurable settings encompass four selectable priorities with the range 0 (lowest priority) to 3 (highest priority). A user may change the input priorities at any time. In the automatic switch modes, input priority changes may cause immediate input selection changes.

Hold-off Counter

A configurable down-counter applicable to the “Automatic with holdover” selection mode. The purpose of this counter is a deferred, user-configurable, input switch after an LOS event. The hold-off counter is triggered by a transition of ST_REF upon detection of an LOS event. The counter expires when a zero-transition occurs; this triggers a new reference clock selection. The counter is clocked by the frequency-divided VCXO-PLL signal. The CNTR setting determines the hold-off counter frequency divider and the CNTH setting the start value of the hold-off counter. For instance, set CNTR to a value of $\div 131072$ to achieve 937.5 Hz (or a period of 1.066 ms at $f_{VCXO} = 122.88\text{MHz}$): the 8-bit CNTH counter is clocked by 937.5Hz and the user-configurable hold-off period range is 0ms (CNTH = 0x00) to 272ms (CNTH = 0xFF). After the counter expires, it reloads automatically from the CNTH SPI register. After the LOS status bit (LS_CLK_n) for the corresponding input CLK_n has been cleared by the user, the input is enabled for generating a new LOS event.

The CNTR counter is only clocked if the device is configured in the clock selection mode “Automatic with holdover” AND the selected reference clock experiences an LOS event. Otherwise, the counter is automatically disabled (not clocked).

Revertive Switching

Revertive switching: is only applicable to the two automatic switch modes shown in Table 11. Revertive switching enabled: Re-validation of any non-selected input clock(s) will cause a new input selection according to the user-preset input priorities (revertive switch). An input switch is only done if the re-validated input has a higher priority than the currently selected reference clock.

Revertive switching disabled: Re-validation of a non-selected input clock has no impact on the clock selection. Default setting is revertive switching disabled.

Short-Term Holdover

If an LOS event is detected on the reference clock designated by the SEL[1:0] bits:

- Holdover begins immediately
- ST_REF, LS_REF go low immediately
- No transitions will occur of the active REF clock; ST_SEL[1:0] does not change
- The hold-off countdown is not active

When the designated reference clock resumes and has met the programmed validation count of consecutive rising edges:

- Holdover turns off
- ST_SEL[1:0] does not change
- ST_REF returns to 1

LS_REF can be cleared by an SPI write of 1 to that register

Automatic with Holdover (nM/A[1:0] = 11)

If an LOS event is detected on the active reference clock:

- Holdover begins immediately
- Corresponding ST_REF and LS_REF go low immediately
- Hold-off countdown begins immediately.

During this time, all clocks continue to be monitored and their respective ST_CLK, LS_CLK flags are active. LOS events will be indicated on ST_CLK, LS_CLK when they occur.

If the active reference clock resumes and is validated during the hold-off countdown:

- its ST_CLK status flag will return high and the LS_CLK is available to be cleared by an SPI write of 1 to that register bit.
- No transitions will occur of the active REF clock; ST_SEL[1:0] does not change. LS_REF can be cleared by an SPI write of 1 to that register.
- Revertive bit has no effect during this time (whether 0 or 1)

When the hold-off countdown reaches zero:

- If the active reference has resumed and has been validated during the countdown, it will maintain being the active reference clock
 - ST_SEL1:0 does not change
 - ST_REF returns to 1
 - LS_REF can be cleared by an SPI write of 1 to that register
 - Holdover turns off and the VCXO-PLL attempts to lock to the active reference clock
- If the active reference has not resumed, but another (sorted by next priority) clock input CLK_n is validated, then
 - ST_SEL1:0 changes to the new active reference
 - ST_REF returns to 1
 - LS_REF can be cleared by an SPI write of 1 to that register
 - Holdover turns off
- If there is no validated CLK:
 - ST_SEL1:0 does not change
 - ST_REF remains low
 - LS_REF cannot be cleared by an SPI write of 1 to that register
 - Holdover remains active

Revertive capability returns if REVS = 1.

VCXO-PLL Lock Detect (LOLV)

The VCXO-PLL lock detect circuit uses the signal phase difference at the phase detector as loss-of-lock criteria. Loss-of-lock is reported if the actual phase difference is larger than a configurable phase window set by the Φ_{MV0} and Φ_{PV} configuration bits. Configuration of the width window allows for a application-specific loss of lock reporting. A loss-of-lock state is reported through the nST_LOLV and nLS_LOLV status bit, see Table 24.

Setting the BLOCK_LOLV register bit will block to the VCXO-PLL lock status from being reported to the LOCK pin.

Loss-of-Lock Window Description

The selected clock input signal is the reference signal (CLK) for lock detection. The rising edge of CLK defines the reference point t_0 . Φ_{PV} configures the start of the lock window t_S (which occurs before t_0), and Φ_{MV0} configures the end of the window t_E (which occurs after t_0). The width of the lock window is defined by $t_E - t_B$. The VCXO-PLL declares lock when the rising edge of the feedback signal (FB) is within this window, otherwise the PLL reports loss-of-lock.

Figure 3. Lock Detect Window

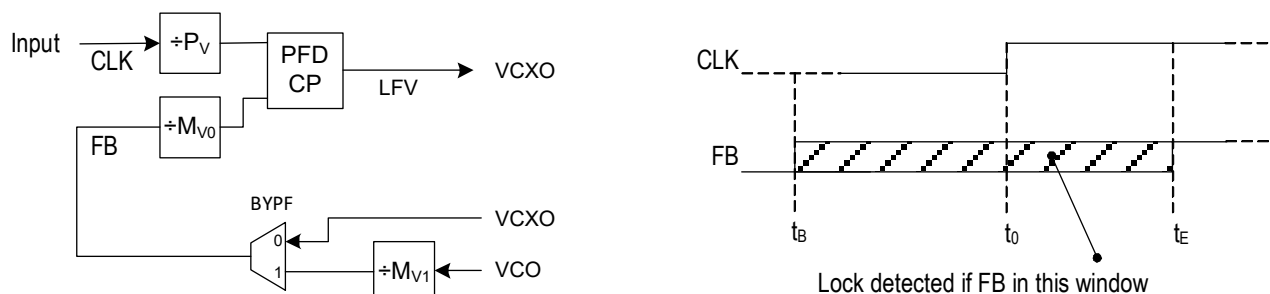

Table 12. t_B and t_E Calculation

Operation	Jitter Attenuation, Dual-PLL with deterministic Input-to-Output Delay (BYPV = 0, BYPF = 1)	Jitter Attenuation, Dual-PLL (BYPV = 0, BYPF = 0)
t_B	$t_B = -\frac{2^{\Phi_{PV}} - 1}{f_{CLK}}$	
t_E	$t_E = \frac{(2^{\Phi_{MV0}} - 1) \cdot M_{V1}}{f_{VCO}}$	$t_E = \frac{2^{\Phi_{MV0}} - 1}{f_{VCXO}}$

Figure 3 shows that Φ_{PV} configures the start and Φ_{MV0} the end of the window in integer multiples of PLL input and feedback periods. Both Φ_{PV} and Φ_{MV0} use 3 configuration bits with valid settings from 010 to 111 (2 to 7, decimal). This range allows configuring both t_B and t_E from 3 to 127 periods of the input signal (T_{IN}) and the feedback signal (T_{FB}), respectively. is implied.

Loss-of-Lock Window Configuration Example

With given P_V , M_{V0} and M_{V1} divider values, select the corresponding Φ_{PV} and Φ_{MV0} settings from Table 13 and apply the Φ_{PV} and Φ_{MV0} values to the $\Phi_{PV}[1:0]$ and $\Phi_{MV0}[1:0]$ registers. Table 13 shows the lock window calculation formulas. For instance, if an input frequency of 245.76MHz and a P_V divider of 128 is desired, set $\Phi_{PV}[1:0]$ to a binary value of 100 (decimal 4). This results in $t_B = -61.035ns$ (15 periods of 4.069ns). With a VCXO-PLL (BYPF = 0) and a VCXO frequency of 122.88MHz and $M_{V0} = 64$, select 011 (decimal 3) resulting in $t_E = 56.96ns$ (7 periods of 8.138 ns) and an overall lock detect window of $t_E - t_B = 56.96ns + 61.035ns = 118.001ns$. The user may select a smaller lock detect window. For instance, a P_V divider of 128 allows to set $\Phi_{PV}[1:0]$ to 010, 011 or 100 (decimal 2 to 4). Correspondingly, a M_{V0} divider of 64 allows $\Phi_{MV0}[1:0]$ settings from 010 to 011 (decimal 2 to 3). With smaller settings, the lock detect window size is reduced exponentially.

$\Phi_{PV}[1:0] = 000$ will set t_B to $0.5 \times T_{REF}$ and $\Phi_{PV}[1:0] = 001$ will set t_B to $1.5 \times T_{REF}$. $\Phi_{MV0}[1:0] = 000$ will set t_E to $0.5 \times T_{REF}$ and $\Phi_{MV0}[1:0] = 001$ will set t_E to $1.5 \times T_{REF}$.

Table 13. Recommended Lock Detector Phase Window Settings

P_V Divider Value	$\Phi_{PV}[1:0]$ Setting	M_{V0} Divider Value	$\Phi_{MV0}[1:0]$ Setting
1 - 31	N/A	1 - 31	N/A
32 - 63	010	32 - 63	010
64-127	≤ 011	64-127	≤ 011
128-255	≤ 100	128-255	≤ 100
256-511	≤ 101	256-511	≤ 101
512-1023	≤ 110	512-1023	≤ 110
1024 and higher	≤ 111	1024 and higher	≤ 111

FemtoClock NG Loss-of-Lock (LOLF)

FemtoClock NG-PLL loss-of-lock is signaled through the nST_LOLF (momentary) and nLS_LOLF (sticky, resettable) status bits and can reported as hardware signal on the LOCK output as well as an interrupt signal on the nINT output.

Channel, Output, and JESD204B Logic

Channel

Each of the four channels A to D consists of one to two clock and associated one to three SYSREF outputs. Each SYSREF output in a channel can be individually configured to generate JESD204B (SYSREF) signals or copy the clock signal of that channel. The fifth channel (E) consists of two clock outputs without SYSREF support in that channel.

If JESD204B/SYSREF operation is assigned to a QREF output, the channel logic controls the outputs: outputs automatically turn on and off in a SYSREF sequence. QREF outputs configured to clock operation can individually configure output states.

Table 14. Channel Configuration^[a]

MUX _r	0	1
Description	Clock configuration	JESD204B
QCLK _y	Clock signal	Clock signal
QREF _r		SYSREF/JESD204B
Frequency Divider	QCLK _y and QREF _r : N _x	QCLK _y : N _x QREF _r : N _S (Global to all QREF _r)
Phase Delay	QCLK _y and QREF _r : Φ_{CLK_x} Φ_{REF_r} settings do not apply	QCLK _y : Φ_{CLK_x} QREF _r : Φ_{REF_r}
Power Down	Per output	Per channel
Output Enable	Per output	Per output

[a] x = A to E. y = A0, A1, B0, B1, C, D, E0, E1; r = A0, A1, A2, B0, B1, C, D

Differential Outputs

Table 15. Output Features

Output	Style	Amplitude ^[a]	Disable	Power Down	Termination
QCLK _y , QREF _r (Clock)	LVPECL	250-1000mV	Yes	Yes	50Ω to V _T
	LVDS	4 steps			100Ω differential ^[b]
QREF _r (SYSREF)	LVDS	500mV A[1:0] = 01	Controlled by SYSREF ^[c]		100Ω differential ^[b]
QCLKV	LVPECL	250-750mV	Yes	Yes	50Ω to V _T
	LVDS	3 steps			100Ω differential ^[b]

[a] Amplitudes are measured single-endedly. Differential amplitudes supported are 500, 1000, 1500, and 2000mV.

[b] AC coupling and DC coupling supported.

[c] State of SYSREF outputs is controlled by an internal SYSREF state machine.

Table 16. Individual Clock Output Settings^[a]

PD ^[b]	STYLE	EN ^[c]	A[1:0] ^[d]	Output Power	Termination	State	Amplitude (mV)
1	X	X	X	Off	100Ω differential or no termination	Off	X
0	0	0	XX	On	100Ω differential (LVDS)	Disable (logic low)	X
		1	00			Enable	250
			01				500
			10				750
			11				1000
	1	0	XX		50Ω to V _T (LVPECL)	Enable	X
		1	00		50Ω to V _T = V _{DD_V} - 1.50V (LVPECL)		250
			01		50Ω to V _T = V _{DD_V} - 1.75V (LVPECL)		500
			10		50Ω to V _T = V _{DD_V} - 2.00V (LVPECL)		750
			11		50Ω to V _T = V _{DD_V} - 2.25V (LVPECL)		1000

- [a] Applicable to clock outputs: QCLK_y and QREF_r outputs in clock mode (MUX_r = 0).
- [b] Power-down modes are available for the individual channels A-E and the outputs QCLK_y (A0 to E1).
- [c] Output enable is supported on each individual QCLK_y and QREF_r output.
- [d] Output amplitude control is supported on each individual QCLK_y and QREF_r output.

Table 17. Individual SYSREF Output Settings^[a]

PD	STYLE	EN	nBIAS	A[1:0]	Output Power	Termination	State	Amplitude (mV)
1	X	X	X	X	Off	100Ω differential or no termination	Off	X
0	0	0	0	01	On ^[b]	100Ω differential (LVDS)	Disable (logic low)	X
		1					Enable	500
		X	Line bias ^[c]	XX				
	1	0	0	01		50Ω to V _T = V _{DD_V} - 1.50V (LVPECL)	Disable (logic low)	X
		1					Enable	500

- [a] Applicable QREF_r outputs when configured as SYSREF output (MUX_r = 1).
- [b] Output amplitude should be set to a 500mV swing (A[1:0] to 01) by SPI. SYSREF output states are controlled by an internal state machine. An internal SYSREF event will automatically turn SYSREF outputs on. After the event, outputs are automatically turned off. Setting nBIAS = 1 will bias powered-off outputs to the LVDS midpoint voltage.
- [c] Output (both Q, and nQ) bias the line to the differential signal cross-point voltage. Available if output is AC-coupled and set to LVDS style.

Table 18. QCLKV (VCXO-PLL Output) Settings

nPD	STYLE	A[1:0]	Output Power	Termination	Amplitude (mV)
0	X	X	Off	100Ω differential (LVDS) or no termination	X
1	0	00	On	100Ω differential (LVDS)	250
		01			500
		10			750
		11			
	1	00		50Ω to $V_T = V_{DD_Y} - 1.50V$ (LVPECL)	250
		01		50Ω to $V_T = V_{DD_Y} - 1.75V$ (LVPECL)	500
		10			
		11		50Ω to $V_T = V_{DD_Y} - 2.00V$ (LVPECL)	750

Table 19. QREF_r Setting for JESD204B Applications

BIAS_TYPE	nBIAS_r	QREF_r Outputs (LVDS, 500mV Amplitude)			Application
		Initial	During SYSREF Event	SYSREF Completed	
0	0	Static low (QREF = L, nQREF_r = H)	Start switching for the number of configured SYSREF pulses	Released to static low (QREF = L, nQREF_r = H)	QREF_r DC coupled
	1	Static low (QREF = L, nQREF_r = H)			
1	0	Static LVDS crosspoint level (QREF = nQREF_r = VOS)	Start switching for the number of configured SYSREF pulses	Released to static LVDS crosspoint level (QREF = nQREF_r = VOS)	QREF_r AC coupled
	1	Static LVDS crosspoint level (QREF = nQREF_r = VOS)			

Output Phase Delay

Output phase delay is independently supported on both clock and SYSREF outputs.

The phase delay on clock outputs Φ_{CLK_x} , SYSREF outputs coarse delay Φ_{REF_r} and global delay Φ_{REF_s} is derived from the internal VCO frequency of the second PLL (FemtoClock NG PLL). In configurations bypassing the second PLL by setting SRC = 1, the delay unit is derived from the frequency of the external VCXO: use f_{VCXO} instead of f_{VCO} in [Table 20](#)

Table 20. Delay Circuit Settings^[a]

Delay Circuit	Unit	Steps	Range (ns)	Alignment ^[b]
Clock ^[c] Φ_{CLK_x}	$\frac{1}{f_{VCO}} = 254\text{ps}$	256	0 – 64.84 ^[d]	Incident rising clock edges are aligned, independent on the divider N_x across channels
SYSREF Φ_{REF_r}	Coarse delay: $\frac{1}{f_{VCO}} = 127\text{ps}$	8	0 – 0.89 ^[d]	SYSREF rising edge is aligned to the incident rising clock edge across channels
	Fine delay: 0, 25, 50, 75, 85, 110, 135, 160ps	8	0 – 0.160 ^[e]	
SYSREF (Global) Φ_{REF_s}	$\frac{2}{f_{VCO}} = 509\text{ps}$	256	0 – 129.7 ^[d]	Global alignment of SYSREF signals

[a] Supports ≥ 12 SYSREF rising edge stops within a device clock period of 4.096ps (245.76MHz) and 8.137 ns (122.88MHz), respectively.

[b] Default configuration (all delay settings = 0).

[c] Clock output inversion supported by setting phase delay to 180° setting.

[d] Exact delay value.

[e] $\pm 20\%$ delay variation over PVT.

Configuration for JESD204B Operation

Synchronizing SYSREF and Clock Output Dividers

The SYNC[5:0] divider controls the release of SYSREF pulses at coincident QCLK_y clock edges. For SYSREF operation, set the SYNC divider value to the least common multiple of the clock divider values N_x ($x = A$ to E). For instance, if $N_A = N_B = \div 2$, $N_C = N_D = \div 3$, $N_E = \div 4$, set the SYNC divider to $\div 12$.

SYSREF Generation

A SYSREF event is the generation of one or more consecutive pulses on the QREF outputs. An event can be triggered by SPI commands or by a signal-transition on the EXT_SYS or CLK3 input. The number of SYSREF pulses generated is programmable from 1 to 255. The SYSREF signal can also be programmed to be continuous. The SYSREF pulse rate is configurable to the frequencies shown in [Table 21](#). SYSREF output pulses are aligned to coincident rising clock edges of the clock outputs QCLK_y. Device settings for phase alignment between QCLK_y and QREF_r outputs is detailed in the section, [QCLK to QREF Phase Alignment](#). The following SYSREF pulse generation modes are available and configurable by SPI:

- Counted pulse mode – 1 to 255 pulses are generated by the device. SYSREF activity stops automatically after the transmission of the selected number of pulses and the QREF output powers down.
- Continuous mode – The SYSREF signal is a clock signal.

The generation of SYSREF pulses is configured by SPI commands and is available after the initial setup of output clock divider and QREF phase delay stages. A SYSREF event will automatically turn on the SYSREF outputs. After the event, SYSREF outputs are automatically turned off (power-down). SYSREF outputs with the nBIAS bit set high will bias the outputs at the LVDS crosspoint voltage level (requires BIAS_TYPE = 1).

Table 21. SYSREF Generation^[a]

N _S	SYSREF Operation (f _{SYSREF})
	f _{VCO} = 3932.16MHz
÷80, ÷160, ÷320, ÷640, ÷1280, ÷2560, ÷5120	49.152, 24.576, 12.288, 6.144, 3.072, 1.536, 0.768
÷96, ÷192, ÷288, ÷576, ÷1024, ÷2048, ÷3072	40.96, 20.48, 10.24, 5.12, 2.56, 1.92, 1.28
÷120, ÷240, ÷480, ÷960, ÷1920, ÷2880	32.768, 16.384, 8.192, 4.096, 2.048, 1.024
÷128, ÷256, ÷512, ÷1024, ÷2048, ÷4096	30.72, 15.36, 7.68, 3.84, 1.92, 0.96

[a] Example frequencies.

Internal SYSREF Generation

SYSREF generation is set to internal (SRG = 0). The SRO setting defines if SYSREF pulses are counted or continuous and the NS[7:0] divider sets the frequency. In counted pulse mode, the SRPC register contains the number of pulses to generate. Any number from 1 to 255 pulses may be generated. SYSREF pulses are generated upon completion of the SPI command RS (SYSREF release). Setting RS activates the SYSREF outputs, loads the number of pulses from the SRPC register and starts the generation of SYSREF pulses synchronized to the incident edge of the clock signals. After the programmed number of pulses are generated, SYSREF outputs will go into logic low state or bias the output voltage to the static LVDS crosspoint level (see Table 19 for settings and details). In continuous mode, SYSREF is a clock signal and the content of the SRPC signal is ignored. For proper operation in this mode, set the SR_INSEL bit to 0.

External SYSREF Generation

SYSREF generation is set to external (SRG = 1): SYSREF pulses are generated in response to the detection of a rising edge at the EXT_SYS. See Table 22 for selection of the active, external SYSREF input. The EXT_SYS input rising edge releases SYSREF pulses. Both SRO and SRPC register settings apply as in internal SYSREF generation mode for generating single shot and repetitive SYSREF output signals. Set RS = 1 to prepare for SYSREF generation; the generation of SYSREF pulses is triggered by a rising edge at EXT_SYS pin.

Table 22. External SYSREF Input

SR_INSEL	Operation
0 (default)	EXT_SYS (single-ended) is the external SYSREF input
1	CLK_3 (differential) is the external SYSREF input. CLK_3 is not available as clock input to drive the first-stage PLL.

QCLK to QREF (SYSREF) Phase Alignment

Figure 4 and Table 23 show how to achieve output phase alignment between the QCLK_y clock and the QREF_r SYSREF outputs. Output phase will be different for different N_x dividers. For a given example in Figure 4, the closest (smallest phase error) output alignment is achieved by setting the clock phase delay register Φ_{CLK_y} to 0x00, the coarse SYSREF output phase delay register Φ_{REF_r} to 0x01, fine SYSREF delay to $\Phi_{\text{REF}_r_F} = 1$ and the global Φ_{REF_S} delay register to 0x29. With a SYSREF phase delay setting of $\Phi_{\text{REF}_r} = 0x01$, $\Phi_{\text{REF}_r_F} = 0$, the QREF_r output phase is in advance of the QCLK_y phase, which is applicable in JESD204B application. Phase delay settings and propagation delays are dependent on the clock and SYSREF frequency dividers, but independent of the SYSREF generation mode (SRG = 0 or SRG = 1). Recommended phase delay settings for several device configurations are shown in Table 23.

Figure 4. QCLK to QREF Phase Alignment

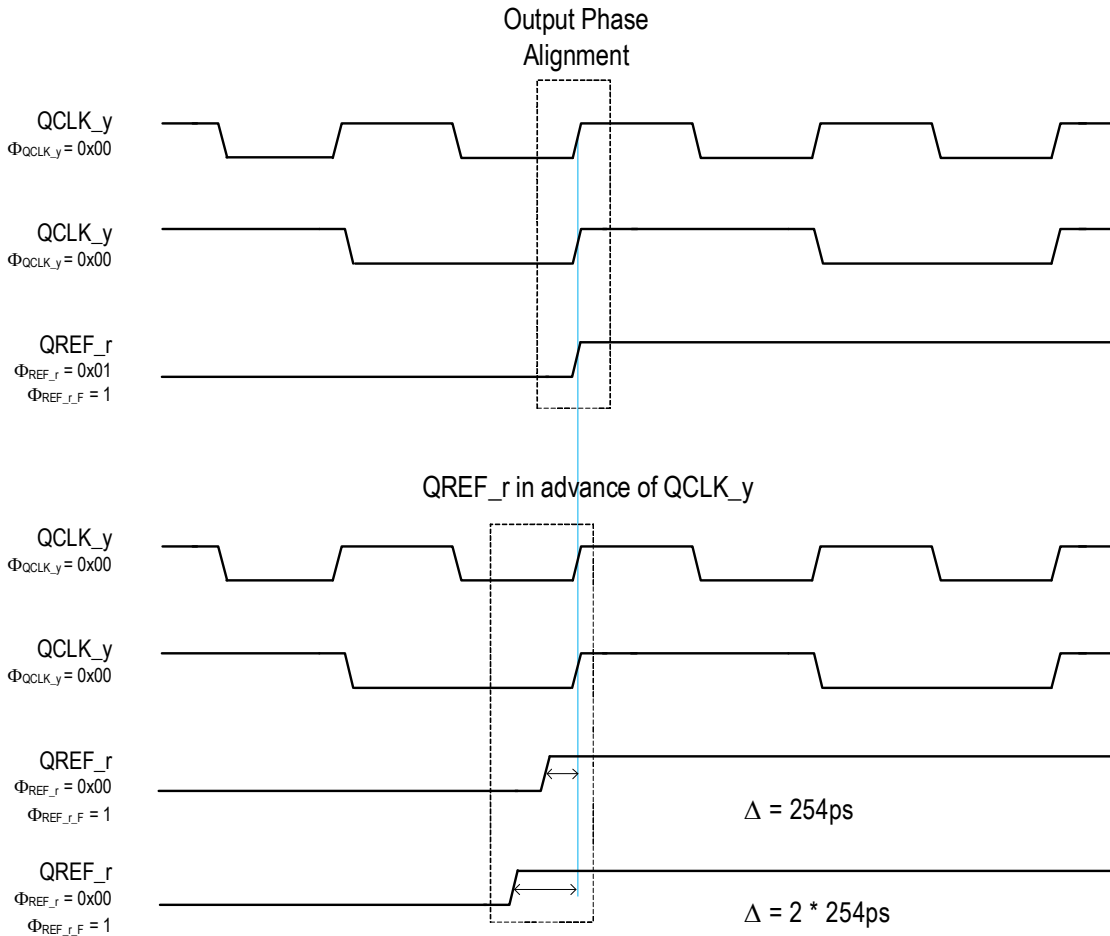

Table 23. Recommended Delay Settings for Closest Clock-SYSREF Output Phase Alignment^[a]

Divider Configuration	Φ_{CLK_y}	Φ_{REF_r}	$\Phi_{\text{REF}_r_F}$	Φ_{REF_S}
N _{A-E} = ÷3 N _S = ÷384	0x00	0x01	1	0x29
N _{A-E} = ÷3, ÷6, ÷12 N _S = ÷384	0x00	0x01	1	0x29
N _{A-E} = ÷8 N _S = ÷384	0x00	0x03	1	0x00

[a] QCLK and QREF outputs are aligned on the incident edge.

Deterministic Phase Relationship and Phase Alignment

Input to output delay is deterministic when the device is configured as dual PLL with the $BYPV = 0$, $BYPF = 1$ (PLL feedback path through $M_{V0} \times M_{V1}$). Refer to the application note [AN-952: 8V19N480/490 Design Guide for JESD204B Output Phase Alignment and Termination](#) for additional information on phase alignment, termination and coupling techniques.

Status Conditions and Interrupts

The device has an interrupt output to signal changes in status conditions. The device has several conditions that can indicate faults and status changes in the operation of the device. These are shown in [Table 24](#) and can be monitored directly in the status registers. Status bits (named: *ST_condition*) are read-only and reflect the momentary device status at the time of read-access. Several status bits are also copied into latched bit positions (named: *LS_condition*). The latched version is controlled by the corresponding fault and status conditions and remains set (“sticky”) until reset by the user by writing 1 to the status register bit. The reset of the status condition only has an effect if the corresponding fault condition is removed, otherwise, the status bit will set again. Setting a status bit on several latched registers can be programmed to generate an interrupt signal (nINT) via settings in the Interrupt Enable bits (named: *IE_condition*). A setting of 0 in any of these bits will mask the corresponding latched status bit from affecting the interrupt status pin. Setting all IE bits to 0 has the effect of disabling interrupts from the device. Interrupts are cleared by resetting the appropriate bit(s) in the latched register after the underlying fault condition has been resolved. When all valid interrupt sources have been cleared in this manner, this will release the nINT output until the next unmasked fault

Table 24. Status Bit Functions

Status Bit		Function			Interrupt Enable Bit
Momentary	Latched	Description	Status if Bit is:		
			1	0	
ST_CLK_0	LS_CLK_0	CLK 0 input status	Active	LOS	IE_CLK_0
ST_CLK_1	LS_CLK_1	CLK 1 input status	Active	LOS	IE_CLK_1
nST_LOLV ^[a]	nLS_LOLV	VCXO-PLL loss of lock	Locked	Loss of lock	IE_LOLV
nST_LOLF ^[b]	nLS_LOLF	FemtoClock NG-PLL loss of lock	Locked	Loss of lock	IE_LOLF
nST_HOLD	nLS_HOLD	Holdover	Not in holdover	Device in holdover	IE_HOLD
ST_VCOF	—	FemtoClock NG VCO calibration	Not completed	Completed	—
ST_SEL[1:0]	—	Clock input selection	00 = CLK_0 01 = CLK_1 not defined not defined		—
ST_REF	LS_REF	PLL reference status	Valid reference	Reference lost ^[c]	IE_REF

[a] Setting the BLOCK_LOLV register bit will block the LOLV status bit from affecting the LOCK pin.

[b] If the VCXO-PLL is bypassed by setting $BYPV = 1$, VCXO-PLL lock status is blocked from affecting the LOCK pin.

[c] Manual and short-term holdover mode: 0 indicates if the reference selected by SEL[1:0] is lost, 1 if not lost

Automatic with holdover mode: 0 indicates the reference is lost and while still in holdover, or no valid CLK_0 to CLK_1.

Automatic mode: 0 indicates no valid CLK_0 to CLK_1.

Table 25. LOCK Function

Status Bit (PLL)		Status Reported on LOCK Output
nLS_LOLV ^[a] (VCXO-PLL)	nLS_LOLF (FemtoClock NG)	
Locked ^[b]	Locked	1
	Not locked	0
Not locked	Locked	0
	Not locked	0

[a] The LOCK pin will only report the FemtoClock NG PLL status on the LOCK pin if BLOCK_LOLV = 1.

[b] If the VCXO-PLL is bypassed by setting BYPV = 1, VCXO-PLL lock status is blocked from affecting the LOCK pin.

Device Startup, Reset and Synchronization

At startup, an internal POR (power-on reset) resets the device and sets all register bits to their default value. The device forces the VCXO control voltage at the LfV pin to half of the power supply voltage to center the VCXO-frequency. In the default configuration the QCLK_y and QREF_r outputs are disabled at startup. The QCLK_V output is enabled and set to 750mV / LVPECL after power-up.

Recommended Configuration Sequence

- (Optional) set the value of the CPOL and (optional) SDO_ACT register bits to define the SPI read mode and the SPI 3/4-wire mode. If SDO_ACT is not set, the device will be in 3-wire mode with the SDAT pin as SPI I/O.
- Configure all PLL settings, output divider and delay circuits as well as other device configurations.
 - BYPF and BYPV for the desired PLL operation mode and configure the PLL dividers P_V, M_{V0}, M_{V1}, M_F and P_F as required to achieve PLL lock (see [Table 2](#)).
 - VCXO-PLL lock detect window by configuring the phase settings $\Phi_{M_{V0}}$ and Φ_{P_V}
 - Charge pump currents for both PLLs (CPV[4:0] and CPF[4:0]) and POLV for the desired VCXO polarity
 - (optional) OSVEN and OFFSET[4:0] for the VCXO-PLL static phase offset
 - Channel dividers (see [Table 9](#))
 - MUX_r for the desired operation of the QREF_r outputs
 - QCLK_y, QREF_r, and Q_CLKV output features such as desired output power-down state, style, and amplitude. Use the EN_QCLKV_MOD register to make QCLK_V register changes effective.
 - Desired input selection and monitoring modes: this involves nM/A[1:0] and SEL[1:0] for input selection. In any of the automatic modes, configure PRIO[1:0]_n, and REVS. Configure the CNTH[7:0], CNTR[1:0] counters for the desired holdover characteristics and DIV4_VAL, CNTV[1:0] for input revalidation if applicable to the operation mode.
 - Individual Φ_{CLK_X} and Φ_{REF_r} registers and the global delay Φ_{REF_S} register for the desired phase delay between clock and SYSREF outputs; see [\(link to phase alignment section\)](#).
 - Interrupt enable configuration bits IE_{status_condition}, as desired for fault reporting on the nINT output
- For SYSREF operation:
 - Configure the N_S and SYNC divider as described in [Status Conditions and Interrupts](#)
 - Configure the SYSREF registers SRG, SRO and SRPC[7:0] according to the desired SYSREF operation
 - Configure the SR_INSEL register bit if external SYSREF operation is desired.
- Set the initialization bit INIT_CLK. This will initiate all divider and delay circuits and synchronize them to each other. The INIT_CLK bit will self-clear.

5. Set both the RELOCK bit and PB_CAL bit. This step should not be combined with the previous step (setting INIT_CLK) in a multi SPI-byte register access. Both bits will self-clear.
6. Clear the FVCV bit to release the VCXO control voltage and VCXO-PLL will attempt to lock to the input clock signal starting from its center frequency
7. Clear the status flags
8. At this point, the basic configuration of the registers 0x00 to 0x73 should be completed and the SPI transfer ended (set nCS to high level)
9. In a separate SPI write access, enable the outputs as desired by accessing the output-enable registers 0x74 and 0x76.
10. For SYSREF operation: set the RS bit to start (or re-start) generating the configured number of SYSREF pulses. The RS bit will auto-clear.
 - In internal SYSREF generation mode (SRG = 0) the SYSREF pulses are generated as a result of setting the RS bit.
 - In external SYSREF mode the SYSREF pulses are generated at the next rising edge of the EXT_SYS or CLK_1 input.

Reserved registers and registers in the address range 0x78 to 0xFF should not be used. Do not write into any registers in the 0x78 to 0xFF range.

Changing Frequency Dividers and Phase Delay Values

Clock Frequency Divider and Delay

The following procedure has to be applied for a change of a clock divider and phase delay value N_{A-E} , and Φ_{CLKA-E} :

1. (Optional) set the value of the CPOL register to define the SPI read mode, so that SPI settings can be validated by subsequent SPI read accesses.
2. (Optional) disable the outputs whose frequency divider or delay value is changed.
3. Configure the N_{A-E} dividers and the delay circuits Φ_{CLKA-E} to the desired new values.
4. (Optional) configure the SYNC divider if required for synchronization between clock and SYSREF signals.
5. Set the initialization bit INIT_CLK. This will initiate all divider and delay circuits and synchronize them to each other. The INIT_CLK bit will self-clear. During this initialization step, all QCLK_y and QREF_r outputs are reset to the logic low state.
6. Set the RELOCK bit. This step should not be combined with the setting INIT_CLK in a multi SPI-byte register access. Bit will self-clear.
7. (Optional) enable the outputs whose frequency divider was changed.

SYSREF Frequency Divider, Delay and Starting/Re-Starting SYSREF Pulse Sequences

The following procedure has to be applied for a change of a SYSREF divider and phase delay value N_S and Φ_{REF_S} :

1. (Optional) set the value of the CPOL register to define the SPI read mode, so that SPI settings can be validated by subsequent SPI read accesses.
2. (Optional) disable the outputs whose frequency divider or delay value is changed.
3. Configure any N_S divider and any delay circuits Φ_{REF_S} to their desired new values.
4. Configure the SYNC divider if required for synchronization between clock and SYSREF signals.
5. Set the initialization bit INIT_CLK. This will initiate all divider and delay circuits and synchronize them to each other. The INIT_CLK bit will self-clear. During this initialization step, all QCLK_y and QREF_r outputs are reset to the logic low state.
6. Set the RELOCK bit. This step should not be combined with the setting INIT_CLK in a multi SPI-byte register access. Bit will self-clear.
7. Set the SRO bit to counted pulse mode, or to continue pulse mode, as desired.
8. (Optional) enable the outputs whose frequency divider was changed.

9. For SYSREF operation, set the RS bit to start (or re-start) generating the configured number of SYSREF pulses.
 - a. In internal SYSREF generation mode (SRG = 0) the SYSREF pulses are generated as a result of setting the RS bit. Set RS for each repeated SYSREF generation.
 - b. In external SYSREF mode the SYSREF pulses are generated at the next rising edge of the EXT_SYS input. Set RS before each rising edge at the EXT_SYS input.

SPI Interface

The device has a configurable 3-wire/4-wire serial control port capable of responding as a slave in an SPI configuration to allow read and write access to any of the internal registers for device programming or read back. The SPI interface consists of the SCLK (clock), SDAT (serial data input and output in 3-wire mode, input in 4-wire mode), SDO (serial data output in 4-wire mode) and nCS (chip select) pins. After power-up, the SPI interface is in 3-wire mode. The SDO_ACT register bit controls the SPI 3/4 wire configuration. SDO_ACT should be set at after startup if 4-wire operation is desired. A data transfer consists any integer multiple of 8 bits and is always initiated by the SPI master on the bus. Internal register data is organized in SPI bytes of 8 bit each.

If nCS is at logic high, the SDAT data I/O is in high-impedance state and the SPI interface of the device is disabled.

In a write operation, data on SDAT will be clocked in on the rising edge of SCLK. In a read operation, data on SDAT/SDO will be clocked out on the falling or rising edge of SCLK depending on the CPOL setting (CPOL = 0: output data changes on the falling edge, CPOL = 1: output data changes on the rising edge).

Starting a data transfer requires nCS to set and hold at logic low level during the entire transfer. Setting nCS = 0 will enable the SPI interface with SDAT in data input mode. The master must initiate the first 8-bit transfer. The first bit presented by the SPI master in each transfer is the LSB (least significant bit). The first bit presented to the slave is the direction bit R/nW (1 = Read, 0 = Write) and the following seven bits are the address bits A[0:6] pointing to an internal register in the address space 0 to 127.

Read operation from an internal register: a read operation starts with an 8 bit transfer from the master to the slave: SDAT is clocked on the *rising* edge of SCLK. The first bit is the direction bit R/nW which must be to 1 to indicate a read transfer, followed by 7 address bits A[0:6]. After the first 8 bits are clocked into SDAT (in 3-wire mode), the SDAT I/O changes to output: The register content addressed by A[0:6] are loaded into the shift register and the next 8 SCLK *falling* (CPOL = 1) clock cycles will then present the loaded register data on the SDAT (3-wire mode) / SDO (4-wire-mode) output and transfer these to the master. Transfers must be completed with de-asserting nCS after any multiple 8 SCLK cycles. If nCS is de-asserted at any other number of SCLKs, the SPI behavior is undefined. SPI byte (8-bit) and back-to-back read transfers of multiple registers are supported with an address auto-increment. During multiple transfers, nCS must stay at logic low level and SDAT (SDO) will present multiple registers (A), (A+1), (A+2), etc. with each 8 SCLK cycles. During SPI Read operations, the user may continue to hold nCS low and provide further bytes of data for up to a total of 127 bytes in a single block read.

Write operation to a device register: During a write transfer, a SPI master transfers one or more bytes of data into the internal registers of the device. A write transfer starts by asserting nCS to low logic level. The first bit presented by the master must set the direction bit R/nW to 0 (Write) and the 7 address bits A[0:6] must contain the 7-bit register address. Bits D0 to D7 contain 8 bit of payload data, which is written into the register addressed by A[0:6] at the end of a 8-bit write transfer. Multiple, subsequent register transfers from the master to the slave are supported by holding nCS asserted at logic low level during write transfers. The 7 bit register address will auto-increment. Transfers must be completed with de-asserting nCS after any multiple 8 SCLK cycles. If nCS is de-asserted at any other number of SCLKs, the SPI behavior is undefined.

End of transfer: After nCS is de-asserted to logic 1, the SPI bus is available to transfers to other slaves on the SPI bus. See also the READ diagram (Figure 5) and WRITE (Figure 6) displaying the transfer of two bytes of data from and into registers.

Registers 0x78 to 0xFF. Registers in the address range 0x78 to 0xFF should not be used. Do not write into any registers in the 0x78 to 0xFF range.

Figure 5. Logic Diagram: Read Data (SPI 3-wire) from Registers for CPOL = 0 and CPOL = 1

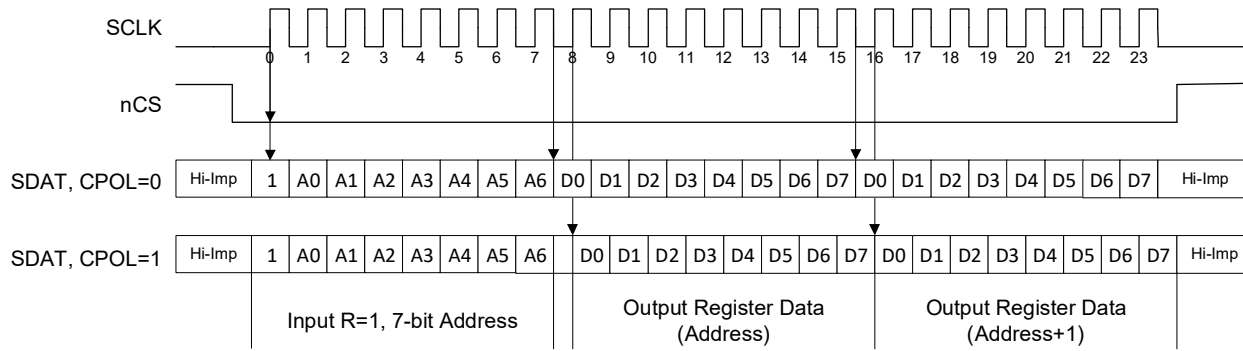

Figure 6. Logic Diagram: Write Data into Registers

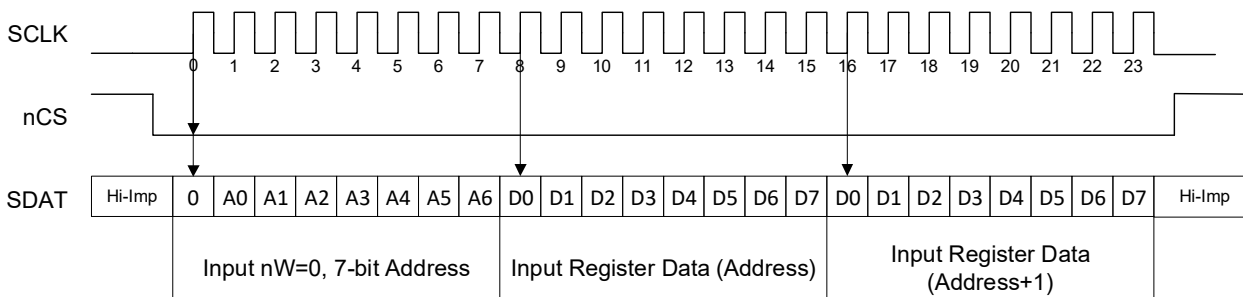

Table 26. SPI Read / Write Cycle Timing Parameters

Symbol	Parameter	Test Condition	Minimum	Maximum	Unit
f_{SCLK}	SCLK frequency			20	MHz
t_{S1}	Setup time, nCS (falling) to SCLK (rising)		5		ns
t_{S2}	Setup time, SDAT (input) to SCLK (rising)		5		ns
t_{S3}	Setup time, nCS (rising) to SCLK (rising)		5		ns
t_{H1}	Hold time, SCLK (rising) to SDAT (input)		5		ns
t_{H2}	Hold time, SCLK (falling) to nCS (rising)		5		ns
t_{PD2F}	Propagation Delay, SCLK (falling) to SDAT (3-wire) or to SDO (4-wire)	CPOL = 0		5	ns
t_{PD2R}	Propagation Delay, SCLK (rising) to SDAT (3-wire) or to SDO (4-wire)	CPOL = 1		5	ns
t_{PD3}	Propagation delay, nCS to SDAT disable			5	ns

Figure 7. SPI Timing Diagram

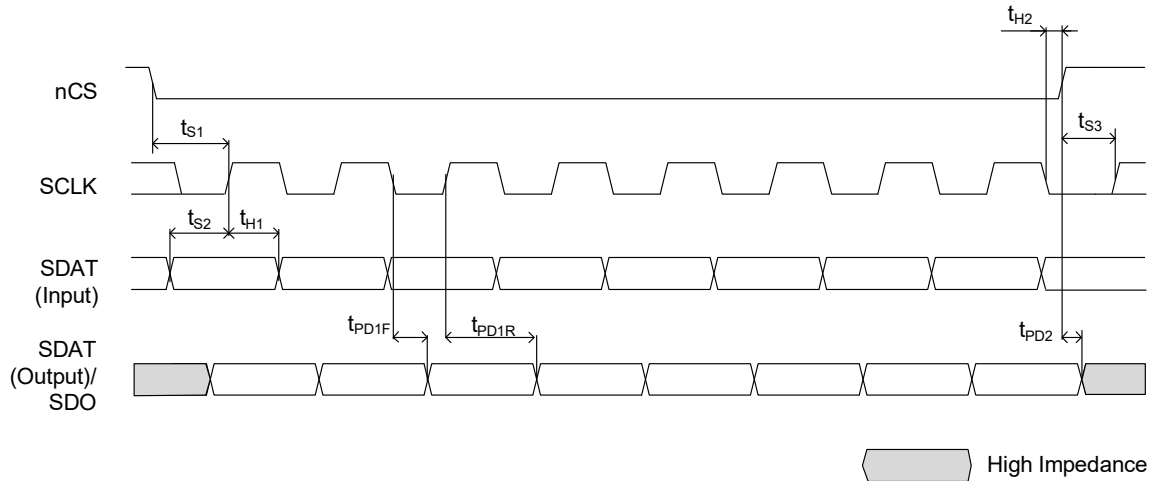

Table 27. Serial Interface Logic Voltage (SPI)^[a]

SELSV0	SPI Interface (SDAT, SDO, SCLK, nCS) Logic Voltage
0 (default)	1.8V
1	3.3V

[a] SELV0 is in register 0x1F, bit D4

Table 28. Serial Interface Logic Voltage (Status Outputs)^[a]

SELSV1	Status Output (nINT, LOCK) Logic Voltage
0 (default)	1.8V
1	3.3V

[a] SELV1 is in register 0x1F, bit D5

Configuration Registers

This section contains all addressable registers, sorted by function, followed for a detailed description of each bit field for each register. Several functional blocks with multiple instances in this device have individual registers controlling their settings, but since the registers have an identical format and bit meaning, they are described only once, with an additional table to indicate their addresses and default values. All writable register fields will come up with a default values as indicated in the Factory Defaults column unless altered by values loaded from non-volatile storage during the initialization sequence.

Fixed read-only bits will have defaults as indicated in their specific register descriptions. Read-only status bits will reflect valid status of the conditions they are designed to monitor once the internal power-up reset has been released. Unused registers and bit positions are Reserved. Reserved bit fields may be used for internal debug test and debug functions.

Table 29. Configuration Registers

Register Address	Register Description
0x00–0x01	PLL Frequency Divider: Φ MV, MV0
0x02–0x03	PLL Frequency Divider: MV1, BYPF
0x04–0x05	VCXO-PLL Control: Φ PV, PV
0x06–0x07	Reserved
0x08–0x09	PLL Frequency Divider: MF
0x0A	VCXO-PLL Control: BYPV
0x0B	Reserved
0x0C	PLL Frequency Divider: SRC, PF, FDF
0x0D–0x0F	Reserved
0x10–0x12	VCXO-PLL Control, Output state QCLK_V
0x13	Reserved
0x14	Input Selection Mode: Priority
0x15	Input Selection Mode: Switching
0x16	Input Selection Mode: CNTH
0x17	Input Selection Mode: CNTR, CNTV
0x18	SYSREF Control: Divider
0x19	SYSREF Control: SYNC, PD
0x1A	SYSREF Control: SRPC
0x1B	SYSREF Control: Φ REF_S
0x1C	SYSREF Control, QCLK_V_EN
0x1D–0x1E	Reserved
0x1F	SYSREF Control, SPI control, SPI/Status output control, QCLK_V_EN
0x20–0x22	Channel A
0x23	Reserved
0x24	Output State QCLK_A0
0x25	Output State QCLK_A1
0x26–0x27	Reserved
0x28	QREF_A0 Delay, MUX

Table 29. Configuration Registers (Cont.)

Register Address	Register Description
0x29	QREF_A1 Delay, MUX
0x2A	QREF_A2 Delay, MUX
0x2B	Reserved
0x2C	Output State QREF_A0
0x2D	Output State QREF_A1
0x2E	Output State QREF_A2
0x2F	Reserved
0x30–0x32	Channel B
0x33	Reserved
0x34	Output State QCLK_B0
0x35	Output State QCLK_B1
0x36–0x37	Reserved
0x38	QREF_B0 Delay, MUX
0x39	QREF_B1 Delay, MUX
0x3A–0x3B	Reserved
0x3C	Output State QREF_B0
0x3D	Output State QREF_B1
0x3E–0x3F	Reserved
0x40–0x42	Channel C
0x43–0x44	Reserved
0x45	Output State QCLK_C
0x46–0x48	Reserved
0x49	QREF_C Delay, MUX
0x4A–0x4C	Reserved
0x4D	Output State QREF_C
0x4E–0x4F	Reserved
0x50–0x52	Channel D
0x53	Reserved
0x54	Output State QCLK_D
0x55–0x57	Reserved
0x58	QREF_D Delay, MUX
0x59–0x5B	Reserved
0x5C	Output State QREF_D
0x5D–0x5F	Reserved
0x60–0x62	Channel E
0x63	Reserved

Table 29. Configuration Registers (Cont.)

Register Address	Register Description
0x64	Output State QCLK_E0
0x65	Output State QCLK_E1
0x66–0x67	Reserved
0x68–0x69	Interrupt Enable
0x6A–0x6B	Reserved
0x6C	Status (Latched)
0x6D	Status (Momentary)
0x6E	Status (Latched)
0x6F	Status (Momentary)
0x70	SYSREF control: RS
0x71–0x73	General Control
0x74–0x75	Output Enable QCLK
0x76	Output Enable QREF
0x77	Reserved
0x78–0x7A	Reserved
0x7B	Reserved
0x7C–0x7F	Reserved
0x80–0xFF	Reserved

Channel and Clock Output Registers

The content of the channel register and clock output registers set the channel state, the clock divider, the QCLK output state and clock phase delay.

Table 30. Channel and Clock Output Register Bit Field Locations

Bit Field Location								
Register Address	D7	D6	D5	D4	D3	D2	D1	D0
0x20: Channel A 0x30: Channel B 0x40: Channel C 0x50: Channel D 0x60: Channel E	Reserved	Reserved				N_A[5:0] N_B[5:0] N_C[5:0] N_D[5:0] N_E[5:0]		
0x21: Channel A 0x31: Channel B 0x41: Channel C 0x51: Channel D 0x61: Channel E				Φ CLK_A[7:0] Φ CLK_B[7:0] Φ CLK_C[7:0] Φ CLK_D[7:0] Φ CLK_E[7:0]				
0x22: Channel A 0x32: Channel B 0x42: Channel C 0x52: Channel D 0x62: Channel E	PD_A PD_B PD_C PD_D PD_E	Reserved	Reserved	Reserved	Reserved	Reserved	Reserved	Reserved
0x24: QCLK_A0 0x25: QCLK_A1	PD_A0 PD_A1	Reserved	Reserved	STYLE_A0 STYLE_A1	A_A0[1:0] A_A1[1:0]		Reserved	
0x34: QCLK_B0 0x35: QCLK_B1	PD_B0 PD_B1	Reserved	Reserved	STYLE_B0 STYLE_B1	A_B0[1:0] A_B1[1:0]		Reserved	
0x45: QCLK_C	PD_C	Reserved	Reserved	STYLE_C	A_C[1:0]		Reserved	
0x54: QCLK_D	PD_D	Reserved	Reserved	STYLE_D	A_D[1:0]		Reserved	
0x64: QCLK_E0 0x65: QCLK_E1	PD_E0 PD_E1	Reserved	Reserved	STYLE_E0 STYLE_E1	A_E0[1:0] A_E1[1:0]		Reserved	
0x74	EN_QCLK_A0	EN_QCLK_A1	Reserved	EN_QCLK_B0	EN_QCLK_B1	Reserved	EN_QCLK_C	EN_QCLK_D
0x75	Reserved	Reserved	Reserved	Reserved	Reserved	Reserved	EN_QCLK_E1	EN_QCLK_E0

Table 31. Channel and Clock Output Register Descriptions^[a]

Bit Field Location						
Bit Field Name	Field Type	Default (Binary)	Description			
N_x[5:0]	R/W	0001 0001	Output Frequency Divider N			
		Value = ÷30	N_x[5:0]Divider Value			
			00 0001	÷1	00 1001	÷10
			00 0010	÷2	00 1010	÷12
			00 0011	÷3	00 1011	÷15
			00 0100	÷4	00 1100	÷16
			00 0101	÷5	00 1101	÷18
			00 0110	÷6	00 1110	÷20
			00 0111	÷8	00 1111	÷24
			00 1000	÷9	01 0000	÷25
			01 0001	÷30	01 0100	÷40
			01 0010	÷32	01 0101	÷48
			01 0011	÷36		
			01 0110	÷50	01 1000	÷60
		01 1001	÷64			
01 1010	÷72	01 1011	÷80			
01 1101	÷96	01 1110	÷100			
		01 1111	÷120			
10 0000	÷128	10 0010	÷160			
10 0001	÷150	10 0011	÷200			
PD_x	R/W	0	0 = Channel x is powered up 1 = Channel x is powered down			
PD_y	R/W	0	0 = Output QCLK_y is powered up 1 = Output QCLK_y is powered down			
ΦCLK_x[7:0]	R/W	0000 0000	CLK_x phase delay ΦCLK_x[7:0]			
			Delay in ps = ΦCLK_x × 254ps (256 steps) 0000 0000 = 0ps ... 1111 1111 = 129.7ns			

Table 31. Channel and Clock Output Register Descriptions^[a]

Bit Field Location				
Bit Field Name	Field Type	Default (Binary)	Description	
A _y [1:0]	R/W	00	QCLK _y Output amplitude	
			Setting for STYLE = 0 (LVDS)	Setting for STYLE = 1 (LVPECL)
			A[1:0] = 00: 250mV A[1:0] = 01: 500mV A[1:0] = 10: 750mV A[1:0] = 11: 1000mV Termination: 100Ω across	A[1:0] = 00: 250mV A[1:0] = 01: 500mV A[1:0] = 10: 750mV A[1:0] = 11: 1000mV Termination: 50Ω to VT
STYLE _y	R/W	0	QCLK _y Output format 0 = Output is LVDS (Requires LVDS 100Ω output termination) 1 = Output is LVPECL (Requires LVPECL 50Ω output termination of the specified recommended termination voltage).	
EN _y	R/W	0	QCLK _y Output enable 0 = QCLK _y Output is disabled at the logic low state 1 = QCLK _y Output is enabled	

[a] x = A, B, C, D, E; y = A0, A1, B0, B1, C, D, E0, E1; r = A0, A1, A2, B0, B1, C, D

QREF Output State Registers

The content of the output registers set the output frequency and divider, several output states, the power state, the output style and amplitude.

Table 32. QREF Output State Register Bit Field Locations^[a]

Bit Field Location								
Register Address	D7	D6	D5	D4	D3	D2	D1	D0
0x28: QREF_A0 0x29: QREF_A1 0x2A: QREF_A2	Reserved	Φ REF_F[1:0]_A0 Φ REF_F[1:0]_A1 Φ REF_F[1:0]_A2		MUX_A0 MUX_A1 MUX_A2		Φ REF_A0[2:0] Φ REF_A1[2:0] Φ REF_A2[2:0]		Φ REF_F[2]_A0 Φ REF_F[2]_A1 Φ REF_F[2]_A2
0x38: QREF_B0 0x39: QREF_B1	Reserved	Φ REF_F[1:0]_B0 Φ REF_F[1:0]_B1		MUX_B0 MUX_B1		Φ REF_B0[2:0] Φ REF_B1[2:0]		Φ REF_F[2]_B0 Φ REF_F[2]_B1
0x49: QREF_C	Reserved	Φ REF_F[1:0]_C		MUX_C		Φ REF_C[2:0]		Φ REF_F[2]_C
0x58: QREF_D	Reserved	Φ REF_F[1:0]_D		MUX_D		Φ REF_D[2:0]		Φ REF_F[2]_D
0x2C: QREF_A0 0x2D: QREF_A1 0x2E: QREF_A2	PD_A0 PD_A1 PD_A2	Reserved	nBIAS_A0 nBIAS_A1 nBIAS_A2	STYLE_A0 STYLE_A1 STYLE_A2		A_A0[1:0] A_A1[1:0] A_A2[1:0]	Reserved	
0x3C: QREF_B0 0x3D: QREF_B1	PD_B0 PD_B1	Reserved	nBIAS_B0 nBIAS_B1	STYLE_B0 STYLE_B1		A_B0[1:0] A_B1[1:0]	Reserved	
0x4C: QREF_C	PD_C	Reserved	nBIAS_C	STYLE_C		A_C[1:0]	Reserved	
0x5C: QREF_D	PD_D	Reserved	nBIAS_D	STYLE_D		A_D[1:0]	Reserved	
0x76	EN_QREF_A0	EN_QREF_A1	EN_QREF_A2	EN_QREF_B0	EN_QREF_B1	EN_QREF_C0	EN_QREF_C1	EN_QREF_D

[a] x = A, B, C, D, E; y = A0, A1, B0, B1, C, D, E0, E1; r = A0, A1, A2, B0, B1, C, D

Table 33. QREF Output State Register Descriptions^[a]

Bit Field Location			
Bit Field Name	Field Type	Default (Binary)	Description
MUX_r	R/W	1	0 = QREF_r output signal source is the channel's clock signal 1 = QREF_r output signal source is the centrally generated SYSREF signal

Table 33. QREF Output State Register Descriptions^[a]

Bit Field Location				
Bit Field Name	Field Type	Default (Binary)	Description	
ΦREF_r[2:0]	R/W	000	SYSREF coarse phase delay ΦREF_r[2:0]	
			Delay in ps = ΦREF_r[2:0] × 255ps (8 steps) 000 = 0ps ... 111 = 1.889 ns	
ΦREF_F[2:0]_r	R/W	000	SYSREF fine phase delay ΦREF_F[2:0]_r	
			Insert a SYSREF fine phase delay in ps (8 steps) in addition to the delay value in ΦREF_r[2:0] 000 = 0ps 001 = 25ps 010 = 50ps 011 = 75ps 100 = 85ps 101 = 110ps 110 = 135ps 111 = 160ps	
nBIAS_r	R/W	0	QREF_r Output Bias Voltage 0 = Output is not voltage biased. 1 = Output is biased to the LVDS cross-point voltage if BIAS_TYPE (register 0x19, bit 7) is set to 1. Bit has no effect if BIAS_TYPE = 0. Output bias = 1 requires AC coupling and LVDS style on the corresponding output.	
A_r[1:0]	R/W	00	QREF_r Output amplitude	
			Setting for STYLE_r = 0 (LVDS)	Setting for STYLE_r = 1 (LVPECL)
			A[1:0] = 00: 250mV A[1:0] = 01: 500mV A[1:0] = 10: 750mV A[1:0] = 11:1000mV Termination: 100Ω across	A[1:0] = 00: 250mV A[1:0] = 01: 500mV A[1:0] = 10: 750mV A[1:0] = 11:1000mV Termination: 50Ω to VT
PD_r	R/W	0	QREF_r Output Power Down 0 = Output is powered up 1 = Output is powered down. STYLE, EN and A[1:0] settings have no effect.	

Table 33. QREF Output State Register Descriptions^[a]

Bit Field Location			
Bit Field Name	Field Type	Default (Binary)	Description
STYLE _r	R/W	0	QREF _r Output format 0 = Output is LVDS (Requires LVDS 100Ω output termination) 1 = Output is LVPECL (Requires LVPECL 50Ω output termination to the specified recommended termination voltage).
EN _r	R/W	0	QREF _r Output enable 0 = Output is disabled at the logic low state 1 = Output is enabled

[a] x = A, B, C, D, E; y = A0, A1, B0, B1, C, D, E0, E1; r = A0, A1, A2, B0, B1, C, D

PLL Frequency Divider Registers

Table 34. PLL Frequency Divider Register Bit Field Locations

Bit Field Location								
Register Address	D7	D6	D5	D4	D3	D2	D1	D0
0x00		ΦMV0[2:0]		PD_MV1			MV0[11:8]	
0x01					MV0[7:0]			
0x02					MV1[7:0]			
0x03	MV1[8]	Reserved	Reserved	Reserved	Reserved	Reserved	Reserved	BYPF
0x04		ΦPV[2:0]		Reserved			PV[11:8]	
0x05					PV[7:0]			
0x08	Reserved	Reserved	Reserved	Reserved	Reserved	Reserved	Reserved	MF[8]
0x09					MF[7:0]			
0x0C	FDf	SRC				PF[5:0]		

Table 35. PLL Frequency Divider Register Descriptions

Bit Field Location																
Bit Field Name	Field Type	Default (Binary)	Description													
ΦMV0[2:0]	R/W	101	Phase of the M _{V0} feedback divider. Determines the PLL lock-detect phase window in conjunction with ΦPV[2:0]. Sampling clock phase is relative to the VCXO-PLL phase detector clock edge. Set ΦMV0[2:0] in relationship to M _{V0} :													
			<table border="1"> <thead> <tr> <th>M_{V0} Divider Value</th> <th>ΦMV0[2:0] Setting</th> </tr> </thead> <tbody> <tr> <td>1-31</td> <td>1-31: Not allowed</td> </tr> <tr> <td>32-63</td> <td>010</td> </tr> <tr> <td>64-127</td> <td>011</td> </tr> <tr> <td>128-255</td> <td>100</td> </tr> <tr> <td>256-511</td> <td>101</td> </tr> <tr> <td>512-1023</td> <td>110</td> </tr> <tr> <td>1024+</td> <td>111</td> </tr> </tbody> </table>	M _{V0} Divider Value	ΦMV0[2:0] Setting	1-31	1-31: Not allowed	32-63	010	64-127	011	128-255	100	256-511	101	512-1023
M _{V0} Divider Value	ΦMV0[2:0] Setting															
1-31	1-31: Not allowed															
32-63	010															
64-127	011															
128-255	100															
256-511	101															
512-1023	110															
1024+	111															
MV0[11:0]	R/W	1100 0000 0000 Value = ±3072	VCXO-PLL Feedback-Divider The value of the frequency divider (binary coding) Range: ±1 to ±4095													
MV1[8:0]	R/W	0 0001 1110 Value = ±30	PLL Feedback-Divider. The value of the frequency divider (binary coding) Range: ±4 to ±511													
PD_MV1	R/W	0 Value = MV1 enabled	PLL Feedback-Divider MV1 Power Down/Disabled 0 = MV1 Divider is enabled 1 = MV1 Divider is powered down and disabled Disabled MV1 to save power consumption in configurations not using the input clock monitors.													
ΦPV[2:0]	R/W	101	Phase of the P _V input (reference) divider. Determines the PLL lock-detect phase window in conjunction with ΦMV0[2:0]. Sampling clock phase is relative to the VCXO-PLL phase detector clock edge. Set ΦPV[2:0] in relationship to P _V :													
			<table border="1"> <thead> <tr> <th>P_V Divider Value</th> <th>ΦPV[2:0] Setting</th> </tr> </thead> <tbody> <tr> <td>1-31</td> <td>1-31: Not allowed</td> </tr> <tr> <td>32-63</td> <td>010</td> </tr> <tr> <td>64-127</td> <td>011</td> </tr> <tr> <td>128-255</td> <td>100</td> </tr> <tr> <td>256-511</td> <td>101</td> </tr> <tr> <td>512-1023</td> <td>110</td> </tr> <tr> <td>1024+</td> <td>111</td> </tr> </tbody> </table>	P _V Divider Value	ΦPV[2:0] Setting	1-31	1-31: Not allowed	32-63	010	64-127	011	128-255	100	256-511	101	512-1023
P _V Divider Value	ΦPV[2:0] Setting															
1-31	1-31: Not allowed															
32-63	010															
64-127	011															
128-255	100															
256-511	101															
512-1023	110															
1024+	111															
PV[11:0]	R/W	1100 0000 0000 Value = ±3072	VCXO-PLL Input Frequency Pre-Divider The value of the frequency divider (binary coding) Range: ±1 to ±4095													

Table 35. PLL Frequency Divider Register Descriptions

Bit Field Location			
Bit Field Name	Field Type	Default (Binary)	Description
MF[8:0]	R/W	0 0001 1110 Value = ÷30	FemtoClock NG Pre-Divider The value of the frequency divider (binary coding) Range: ÷8 to ÷511
PF[5:0]	R/W	00 0000 Value = Bypass	FemtoClock NG Pre-Divider The value of the frequency divider (binary coding) Range: ÷1 to ÷63 00 0000: PF is bypassed
FDF	R/W	0 Value = $f_{VCXO} \div PF$	Frequency Doubler The input frequency of the FemtoClock NG PLL (2nd stage) is: 0 = the output signal of the BYPV multiplexer, divided by the PF divider 1 = the output signal of the BYPV multiplexer, doubled in frequency. Use this setting to improve phase noise. The PF divider has no effect if FDF = 1.
SRC	R/W	0 PLL enabled	Output Divider Source Signal (FemtoClock NG PLL Bypass) 0 = FemtoClock NG PLL is enabled and feeds the output channel dividers. 1 = FemtoClock NG PLL is disabled and bypassed. The VCXO-PLL output signal is frequency divided by the channel dividers.
BLOCK_LOLV	R/W	0 not blocked	Blocks the LOLV status condition from reporting to the LOCK pin. 0 = the LOLV (VCXO-PLL lock) condition is reported to the LOCK pin. 1 = the LOLV (VCXO-PLL lock) condition does not affect the LOCK pin.
SDO_ACT	R/W	0 Value: 3-wire SPI	SPI interface select 0 = 3-wire. SDAT is SPI input and output. SDO is in high-impedance state 1 = 4-wire. SDAT is SPI input, SDO pin is the SPI output
SELSV0	R/W	0 Value: 1.8V	SPI (SDO, SDAT, nCS, SCLK) Logic Voltage Select 0 = 1.8V 1 = 3.3V
SELSV1	R/W	0 Value: 1.8V	Status output (nINT, LOCK) Logic Voltage Select 0 = 1.8V 1 = 3.3V

VCXO-PLL Control Registers

Table 36. VCXO-PLL Control Register Bit Field Locations

Bit Field Location								
Register Address	D7	D6	D5	D4	D3	D2	D1	D0
0x03	MV1[8]	Reserved	Reserved	Reserved	Reserved	Reserved	Reserved	BYPF
0x0A	Reserved	Reserved	Reserved	Reserved	Reserved	Reserved	Reserved	BYPV
0x10	POLV	FVCV	Reserved			CPV[4:0]		
0x11	nPD_QCLK V	STYLE_QCL KV	OSVEN			OFFSET[4:0]		
0x12	Reserved	A_QCLKV[1:0]				CPF[4:0]		

Table 37. VCXO-PLL Control Register Descriptions

Bit Field Location			
Bit Field Name	Field Type	Default (Binary)	Description
BYPF	R/W	0	PLL feedback Bypass 0 = VCXO-PLL feedback divider: M_{V0} 1 = VCXO-PLL feedback divider: $M_{V0} \times M_{V1}$
BYPV	R/W	0	VCXO-PLL Bypass 0 = VCXO-PLL is enabled. 1 = VCXO-PLL is disabled and bypassed.
POLV	R/W	0	VCXO Polarity 0 = Positive polarity. Use for an external VCXO with a positive $f(V_C)$ characteristics 1 = Negative polarity. Use for an external VCXO with a negative $f(V_C)$ characteristics
FVCV	R/W	1	VCXO-PLL Force VC control voltage 0 = Normal operation. 1 = Forces the voltage at the LFV control pin (VCXO input) to $V_{DD_V} / 2$. VCXO-PLL unlocks and the VCXO is forced to its mid-point frequency. FVCV = 1 is the default setting at startup to center the VCXO frequency. FVCV should be cleared after startup to enable the PLL to lock to the reference frequency.
CPV[4:0]	R/W	1 1000 Value: 1.25mA	VCXO-PLL Charge-Pump Current Controls the charge pump current I_{CPV} of the VCXO-PLL. Charge pump current is the binary value of this register plus one multiplied by $50\mu A$. $I_{CPV} = 50\mu A \times (CPV[4:0] + 1)$. CPV[4:0] = 00000 sets ICPV to the min. current of $50\mu A$. Max. charge pump current is 1.6 mA. Default setting is 1.25mA: $((24 + 1) \times 50\mu A)$.

Table 37. VCXO-PLL Control Register Descriptions

Bit Field Location			
Bit Field Name	Field Type	Default (Binary)	Description
nPD_QCLKV	R/W	0	<p>QCLK_V Power State: 0 = Output QCLK_V is powered-down. 1 = Output QCLK_V is powered-up. <i>Power up behavior:</i> QCLK_V output is powered up after startup, while nPD_QCLKV remains at 0. To change the QCLK_V power state, first write the desired new nPD_QCLKV value, then write the EN_QCLKV_MOD[7:0] register to make the change effective.</p>
STYLE_QCLKV	R/W	0	<p>QCLK_V Output Format: 0 = Output is LVDS (requires an LVDS 100Ω output termination). 1 = Output is LVPECL (requires an LVPECL 50Ω output termination of to the specified recommended termination voltage). <i>Power up behavior:</i> QCLK_V output is set to LVPECL after startup, while STYLE_QCLKV remains at 0. To change the QCLK_V output format, first write the desired new STYLE_QCLKV value, then write the EN_QCLKV_MOD[7:0] register to make the change effective.</p>
OSVEN	R/W	0	<p>VCXO-PLL Offset Enable 0 = No offset 1 = Offset enabled. A static phase offset of OFFSET[4:0] is applied to the PFD of the VCXO-PLL</p>
OFFSET[4:0]	R/W	0 0000 Value: 0°	<p>VCXO-PLL Static Phase Offset Controls the static phase detector offset of the VCXO-PLL. Phase offset is the binary value of this register multiplied by 0.9° of the PFD input signal ($\text{OFFSET}[4:0] \times f_{\text{PFD}} \div 400$). Max. offset is $31 \times 0.9^\circ = 27.9^\circ$. Setting OFFSET to 0.0° eliminates the thermal noise of an offset current. If the VCXO-PLL input jitter period T_{JIT} exceeds the average input period: set OFFSET to a value larger than $f_{\text{PFD}} \times T_{\text{JIT}} \times 400$ to achieve a better charge pump linearity and lower in-band noise of the PLL.</p>
CPF[4:0]	R/W	1 1000 Value: 5.0mA	<p>FemtoClock NG-PLL Charge-Pump Current Controls the charge pump current I_{CPF} of the FemtoClock NG PLL. Charge pump current is the binary value of this register plus one multiplied by 200μA. $I_{\text{CPF}} = 200\mu\text{A} \times (\text{CPF}[4:0] + 1)$. CPV[4:0] = 00000 sets I_{CPF} to the min. current of 200μA. Max. charge pump current is 6.4 mA. Default setting is 5.0 mA: $((24+1) \times 200\mu\text{A})$</p>

Table 37. VCXO-PLL Control Register Descriptions

Bit Field Location				
Bit Field Name	Field Type	Default (Binary)	Description	
A_QCLKV[1:0]	R/W	00	QCLK_V Output Amplitude	
			Setting for STYLE_r = 0 (LVDS)	Setting for STYLE_r = 1 (LVPECL)
			A[1:0] = 00: 250mV A[1:0] = 01: 500mV A[1:0] = 10: 500mV A[1:0] = 11: 750mV Termination: 100Ω across	A[1:0] = 00: 250mV A[1:0] = 01: 500mV A[1:0] = 10: 500mV A[1:0] = 11: 750mV Termination: 50Ω to VT
			<p><i>Power up behavior:</i> QCLK_V output is set to 750mV amplitude after startup, while A_QCLKV[1:0] remains at 00.</p> <p>To change the QCLK_V amplitude, first write the desired new A_QCLKV value, then write the EN_QCLKV_MOD[7:0] register to make the change effective.</p>	

Input Selection Mode Registers

Table 38. Input Selection Mode Register Bit Field Locations

Bit Field Location								
Register Address	D7	D6	D5	D4	D3	D2	D1	D0
0x14	PRIO_0[1:0]		PRIO_1[1:0]		PRIO_2[1:0]		PRIO_3[1:0]	
0x15	Reserved	BLOCK_LOR	DIV4_VAL	REVS	nM/A[1:0]		SEL[1:0]	
0x16	CNTH[7:0]							
0x17	CNTR[1:0]		Reserved	Reserved	PD_CLKn		CNTV[1:0]	

Table 39. Input Selection Mode Register Descriptions

Bit Field Location			
Bit Field Name	Field Type	Default (Binary)	Description
PRIO_n[1:0]	R/W	CLK_0: 11 CLK_1: 10	Controls the auto-selection priority of the clock input CLK_n (n = 0...3). If multiple inputs have equal priority, the order within that priority is from CLK_0 (highest) to CLK_3 (lowest). 00 = Priority 0 (lowest) 01 = Priority 1 10 = Priority 2 11 = Priority 3 (highest)
DIV4_VAL	R/W	0 (Value: ÷1)	Pre-divider for CNTV[1:0]. Use the ÷4 pre-divider for input frequencies > 250MHz. 0 = ÷1 1 = ÷4
REVS	R/W	0 (Value: off)	Revertive Switching. The revertive input switching setting is only applicable to the two automatic selection modes shown in Table 11. If nM/A[1:0] = X0, the REVS setting has not meaning. 0 = Disabled: Re-validation of a non-selected input clock has no impact on the clock selection. 1 = Enabled: Re-validation of any non-selected input clock(s) will cause an new input selection according to the pre-set input priorities (revertive switch). An input switch is only done if the re-validated input has a higher priority than the current VCXO-PLL reference clock. Default setting is revertive switching turned off.

Table 39. Input Selection Mode Register Descriptions

Bit Field Location					
Bit Field Name	Field Type	Default (Binary)	Description		
nM/A[1:0]	R/W	00 (Value: Manual Selection)	Reference Input Selection Mode. In any of the manual selection modes (nM/A[1:0] = 00 or 10), the VCXO-PLL reference input is selected by SEL[1:0]. In any of the automatic selection modes, the VCXO-PLL reference input is selected by an internal state machine according to the input LOS states and the priorities in the input priority registers 00 = Manual selection. 01 = Automatic selection (no holdover) 10 = Short-term holdover. 11 = Automatic selection with holdover		
SEL[1:0]	R/W	00 (Value: CLK_0 selected)	VCXO-PLL Input Reference Selection Controls the selection of the VCXO-PLL reference input in the manual selection modes. In automatic selection modes (nM/A[1:0] = X1), SEL[1:0] has no meaning. 00 = CLK_0 01 = CLK_1		
CNTH[7:0]	R/W	1000 0000 (Value: 136ms)	nMA[1:0] = 11 Automatic with holdover: Hold-off counter period. The device initiates a clock fail-over switch upon counter expiration (zero transition). The counters start to counts backwards after an LOS event is detected. The hold-off counter period is determined by the binary number of VCXO-PLL output pulses divided by CNTR[1:0]. With a VCXO frequency of 122.88MHz and CNTR[1:0] = 10, the counter has a period of (1.066 ms × binary setting). After each zero-transition, the counter automatically re-loads to the setting in this register. The default setting is 136ms (VCXO = 122.88MHz: 1/122.88MHz × 2 ¹⁷ × 128)		
CNTR[1:0]	R/W	10 (Value: 2 ¹⁷)	nMA[1:0] = 11 Automatic with holdover: Reference divider		
			CNTR[1:0]	CNTH frequency (period; range)	
				122.88MHz VCXO	38.4MHz VCXO
			00 = f _{VCXO} ÷ 2 ¹⁵		1171Hz (0.853ms; 0-217.6ms)
			01 = f _{VCXO} ÷ 2 ¹⁶	1875Hz (0.533ms; 0-136ms)	
	10 = f _{VCXO} ÷ 2 ¹⁷	937.5Hz (1.066ms; 0-272ms)			

SYSREF, QCLK_V Modification Control Registers

Table 40. SYSREF, QCLK_V Modification Control Register Bit Field Locations

Bit Field Location								
Register Address	D7	D6	D5	D4	D3	D2	D1	D0
0x18					NS[7:0]			
0x19	PD_S	BIAS_TYPE			SYNC[5:0]			
0x1A					SRPC[7:0]			
0x1B					ΦREF_S[7:0]			
0x1C		EN_QCLKV_MOD[7:4]			Reserved	SR_INSEL	SRG	SRO
0x1F	BLOCK_LOLV	SDO_ACT	SELSV1	SELSV0	EN_QCLKV_MOD[3:0]			
0x70	RS	Reserved	Reserved	Reserved	Reserved	Reserved	Reserved	Reserved

Table 41. SYSREF, QCLK_V Modification Control Register Descriptions

Bit Field Location			
Bit Field Name	Field Type	Default (Binary)	Description
NS[7:0]	R/W	00 00 00 00 Value = +64	SYSREF Frequency Divider. The value of the frequency divider is set by the product of $2 \times NS[7] \times NS[6] \times NS[5:4] \times NS[3] \times NS[2] \times NS[1:0]$ NS[7:6] NS[5:4] NS[3] NS[2] NS[1:0]
			00 =>2 00 =>2 00 =>2
			01 =>4 01 =>3 0 =>2 0 =>2 01 =>3
			10 =>8 10 =>4 1 =>4 1 =>4 10 =>4
			11 =>16 11 =>5 11 =>5
The SYSREF contains five serial dividers that can be individually controlled by NS[6], NS[5:4], NS[3], NS[2] and NS[1:0], respectively; and an additional divide-by-two. Example: to achieve a SYSREF divider value of +3840 = $2 \times \{16\} \times \{3\} \times \{4\} \times \{2\} \times \{5\}$: set NS[7:6] = 11, NS[5:4] = 01, NS[3] = 1, NS[2] = 0, and NS[1:0] = 11. If a given output divider can be achieved by multiple NS[7:0] settings, use the highest possible divider in NS[7:6], then in NS[5:4], followed by NS[3], NS[2], and NS[1:0].			
PD_S	R/W	0	SYSREF global power down (incl. global delay ΦS, SYSREF frequency divider NS) 0 = SYSREF functional blocks are powered up. 1 = SYSREF functional blocks are powered down.

Table 41. SYSREF, QCLK_V Modification Control Register Descriptions

Bit Field Location						
Bit Field Name	Field Type	Default (Binary)	Description			
BIAS_TYPE	R/W	1	SYSREF output voltage bias 0 = QREF_r outputs are in a low/high state when nBIAS_r is set to 1 or during a SYSREF event 1 = QREF_r outputs are in a cross-point biased state when nBIAS_r is set to 1 or during a SYSREF event.			
SYNC[5:0]	R/W	0000 0100 (Value = ÷6)	SYSREF Synchronizer divider value. This divider controls the release of SYSREF pulses at coincident QCLK clock edges. For SYSREF operation, set this divider value to the least common multiple of the clock divider values Nx (x = A to E). For instance, if NA = NB = ÷2, NC = ND = ÷3, NE = ÷4 set the SYNC divider to ÷6. SYNC Frequency Divider N SYNC[5:0]Divider Value			
			00 0000	do not use	00 1001	÷10
			00 0001	do not use	00 1010	÷12
			00 0010	÷2	00 1011	÷15
			00 0011	÷3	00 1100	÷16
			00 0100	÷4	00 1101	÷18
			00 0101	÷5	00 1110	÷20
			00 0110	÷6	00 1111	÷24
			00 0111	÷8	01 0000	÷25
			00 1000	÷9		
			01 0001	÷30	01 0100	÷40
			01 0010	÷32	01 0101	÷48
			01 0011	÷36		
			01 0110	÷50	01 1000	÷60
		01 1001	÷64			
01 1010	÷72	01 1011	÷80			
01 1101	÷96	01 1110	÷100			
		01 1111	÷120			
10 0000	÷128	10 0010	÷160			
10 0001	÷150	10 0011	÷200			
SRPC[7:0]	R/W	0000 0010 (Value: 2)	SYSREF pulse count Binary value of the SYSREF pulses generated and output at all enabled QREF outputs. Allows to generate 1 to 255 pulses after each write access. Requires to set SRG = 0 and SRO = 0.			

Table 41. SYSREF, QCLK_V Modification Control Register Descriptions

Bit Field Location			
Bit Field Name	Field Type	Default (Binary)	Description
ΦREF_S[7:0]	R/W	0000 0000	ΦREF_S global SYSREF phase delay. This setting affects all QREF_r outputs configured as SYSREF. ΦREF_S[7:0]
			Delay in ps = ΦREF_S × 509ps (256 steps) 0000 0000 = 0ps ... 1111 1111 = 129.7ns
EN_QCLKV_MOD[7:0]	R/W	0000 0000	Enable QCLK_V Configuration Modifications Set EN_QCLKV_MODE[7:0] to the bit pattern 0100 1011 (0x4B) after QCLK_V configuration bits nPD_QCLKV (0x11, D7), STYLE_QCLKV (0x11, D6) and A_QCLKV[1:0] (0x12, D6:5) have been written. Set EN_QCLKV_MODE[7:4] to any other value, for instance to 0x00, to prevent changes to the nPD_QCLKV, STYLE_QCLKV and A_QCLKV[1:0] bits. If EN_QCLKV_MODE[7:0] is not set to 0x4B, the QCLK_V output is set to its startup configuration (LVPECL, 750mV, power on).
SR_INSEL	R/W	0	SYSREF input select 0 = EXT_SYS is the SYSREF input (single-ended signal support) 1 = CLK_3 is the SYSREF input (differential signal support)
SRG	R/W	0	SYSREF pulse generation 0 = Internal, SPI controlled SYSREF generation using the RS bit. 1 = External controlled SYSREF generation using the EXT_SYS pin.
SRO	R/W	0	SYSREF pulse mode 0 = Counted SYSREF pulse generation mode. Number of pulses is controlled by SRPC[7:0]. 1 = Continuous SYSREF pulse generation.
BLOCK_LOLV	R/W	0 not blocked	Blocks the LOLV status condition from reporting to the LOCK pin. 0 = the LOLV (VCXO-PLL lock) condition is reported to the LOCK pin. 1 = the LOLV (VCXO-PLL lock) condition does not affect the LOCK pin.
SDO_ACT	R/W	0 (Value: 3-wire SPI)	SPI interface select 0 = 3-wire. SDAT is SPI input and output. SDO is in high-impedance state 1 = 4-wire. SDAT is SPI input, SDO pin is the SPI output
SELSV0	R/W	0 (Value: 1.8V)	SPI (SDO, SDAT, nCS, SCLK) Logic Voltage Select 0 = 1.8V 1 = 3.3V

Table 41. SYSREF, QCLK_V Modification Control Register Descriptions

Bit Field Location			
Bit Field Name	Field Type	Default (Binary)	Description
SELSV1	R/W	0 (Value: 1.8V)	Status output (nINT, LOCK) Logic Voltage Select 0 = 1.8V 1 = 3.3V
RS	W only Auto-Clear	X	Set RS = 1 to initiate the SYSREF pulse generation of SRPC-number of pulses. Powers up the SYSREF circuitry and releases the SYSREF pulse(s) as configured. Requires SRG = 0, otherwise no function. RS = 1 also phase-aligns the QREF outputs to the QCLK outputs and adds the programmed delay values into the QREF paths.

Status Registers

Table 42. Status Register Bit Field Locations

Bit Field Location								
Register Address	D7	D6	D5	D4	D3	D2	D1	D0
0x68	Reserved	Reserved	IE_LOLF	IE_LOLV	Reserved	Reserved	IE_CLK_1	IE_CLK_0
0x69	Reserved	Reserved	Reserved	Reserved	Reserved	Reserved	IE_REF	IE_HOLD
0x6C	Reserved	Reserved	nLS_LOLF	nLS_LOLV	Reserved	Reserved	LS_CLK_1	LS_CLK_0
0x6D	ST_SEL[1:0]		nST_LOLF	nST_LOLV	Reserved	Reserved	ST_CLK_1	ST_CLK_0
0x6E	Reserved	Reserved	Reserved	Reserved	Reserved	Reserved	LS_REF	nLS_HOLD
0x6F	Reserved	Reserved	Reserved	Reserved	Reserved	ST_VCOF	ST_REF	nST_HOLD

Table 43. Status Register Descriptions^[a]

Bit Field Location			
Bit Field Name	Field Type	Default (Binary)	Description
IE_LOLF	R/W	0	Interrupt Enable for FemtoClock NG-PLL Loss-of-lock: 0 = Disabled: Setting nLS_LOLF will not cause an interrupt on nINT 1 = Enabled: Setting nLS_LOLF will assert the nINT output (nINT = 0, interrupt)
IE_LOLV	R/W	0	Interrupt Enable for VCXO-PLL Loss-of-lock: 0 = Disabled: Setting nLS_LOLV will not cause an interrupt on nINT. 1 = Enabled: Setting nLS_LOLV will assert the nINT output (nINT = 0, interrupt).

Table 43. Status Register Descriptions^[a]

Bit Field Location			
Bit Field Name	Field Type	Default (Binary)	Description
IE_CLK _n	R/W	0	Interrupt Enable for CLK _n input Loss-of-signal: 0 = Disabled: Setting LS_CLK _n will not cause an interrupt on nINT. 1 = Enabled: Setting LS_CLK _n will assert the nINT output (nINT = 0, interrupt).
IE_REF	R/W	0	Interrupt Enable for LS_REF: 0 = Disabled: any changes to LS_REF will not cause an interrupt on nINT. 1 = Enabled: any changes to LS_REF will assert the nINT output (nINT = 0, interrupt).
IE_HOLD	R/W	0	Interrupt Enable for Holdover: 0 = Disabled: Setting nLS_HOLD will not cause an interrupt on nINT. 1 = Enabled: Setting nLS_HOLD will assert the nINT output (nINT = 0, interrupt).
nLS_LOLF	R/W	—	FemtoClock NG-PLL Loss-of-lock (latched status of nST_LOLF): Read 0 = ≥ 1 Loss-of-lock events detected after the last nLS_LOLF status latch clear. Read 1 = No Loss-of-lock detected after the last nLS_LOLF status latch clear. Write 1 = Clear status latch (clears pending nLS_LOLF interrupt).
nLS_LOLV	R/W	—	VCXO-PLL Loss-of-lock (latched status of nST_LOLV): Read 0 = ≥ 1 Loss-of-lock events detected after the last nLS_LOLV status latch clear. Read 1 = No Loss-of-lock detected after the last nLS_LOLV status latch clear. Write 1 = Clear status latch (clears pending nLS_LOLV interrupt).
LS_CLK _n	R/W	—	Input CLK _n Status (latched status of ST_CLK _n): Read 0 = ≥ 1 LOS events detected on CLK _n after the last LS_CLK _n status latch clear. Read 1 = No Loss-of-signal detected on CLK _n input after the last LS_CLK _n status latch clear. Write 1 = Clear LS_CLK _n status latch (clears pending LS_CLK _n interrupts on nINT).
ST_SEL[1:0]	R	—	Input Selection (momentary): Reference Input Selection Status of the state machine. In any input selection mode, reflects the input selected by the state machine: 00 = CLK ₀ 01 = CLK ₁
nST_LOLF	R	—	FemtoClock NG-PLL Loss-of-lock (momentary): Read 0 = Loss-of-lock event detected. Read 1 = No Loss-of-lock detected. A latched version of this status bit is available (nLS_LOLF).
nST_LOLV	R	—	VCXO-PLL Loss-of-lock (momentary): Read 0 = Loss-of-lock event detected. Read 1 = No Loss-of-lock detected. A latched version of this status bit is available (nLS_LOLV).
ST_CLK _n	R	—	Input CLK _n Status (momentary): 0 = LOS detected on CLK _n . 1 = No LOS detected, CLK _n input is active. Latched versions of these status bits are available (LS_CLK _n).

Table 43. Status Register Descriptions^[a]

Bit Field Location			
Bit Field Name	Field Type	Default (Binary)	Description
LS_REF	R/W	—	PLL Reference Status (latched status of ST_REF): Read 0 = Reference is lost after the last LS_REF status latch clear. Read 1 = Reference is valid after the last LS_REF status latch clear. Write 1 = Clear LS_REF status latch (clears pending LS_REF interrupts on nINT).
nLS_HOLD	R/W	—	Holdover Status Indicator (latched status of nST_HOLD): Read 0 = VCXO-PLL has entered holdover state at least 1 time after the last nLS_HOLD status latch clear. Read 1 = VCXO-PLL is (or attempts to) lock(ed) to an input clock. Write 1 = Clear status latch (clears pending nLS_HOLD interrupt).
ST_VCOF	R	—	FemtoClock NG-PLL Calibration Status (momentary): Read 0 = FemtoClock NG PLL auto-calibration is completed. Read 1 = FemtoClock NG PLL calibration is active (not completed).
ST_REF	R	—	Input Reference Status: 0 = No input reference present. 1 = Input reference is present.
nST_HOLD	R	—	Holdover Status Indicator (momentary): 0 = VCXO-PLL in holdover state, not locked to any input clock. 1 = VCXO-PLL is (or attempts to) lock(ed) to input clock. A latched version of this status bit is available (nLS_HOLD).

[a] CLK_n = CLK_0, CLK_1.

General Control Registers

Table 44. General Control Register Bit Field Locations

Bit Field Location								
Register Address	D7	D6	D5	D4	D3	D2	D1	D0
0x71	INIT_CLK	Reserved	Reserved	Reserved	Reserved	Reserved	Reserved	Reserved
0x72	RELOCK	Reserved	Reserved	Reserved	Reserved	Reserved	Reserved	Reserved
0x73	PB_CAL	Reserved	Reserved	Reserved	Reserved	Reserved	Reserved	CPOL

Table 45. General Control Register Descriptions

Bit Field Location			
Bit Field Name	Field Type	Default (Binary)	Description
INIT_CLK	W only Auto-Clear	X	Set INIT_CLK = 1 to initialize divider functions. Required as part of the startup procedure.
RELOCK	W only Auto-Clear	X	Setting this bit to 1 will force the FemtoClock NG PLL to re-lock.
PB_CAL	W only Auto-Clear	X	Precision Bias Calibration Setting this bit to 1 will start the calibration of an internal precision bias current source. The bias current is used as reference for outputs configured as LVDS and for as reference for the charge pump currents. This bit will auto-clear after the calibration completed. Set as part of the startup procedure.
CPOL	R/W	0	SPI Read Operation SCLK Polarity: 0 = Data bits on SDAT (SPI 3-wire) / SDO (SPI 4-wire) are output at the falling edge of SCLK edge. 1 = Data bits on SDAT (SPI 3-wire) / SDO (SPI 4-wire) are output at the rising edge of SCLK edge.

Electrical Characteristics

Absolute Maximum Ratings

The absolute maximum ratings are stress ratings only. Stresses greater than those listed below can cause permanent damage to the device. Functional operation of the 8V19N492-39 at absolute maximum ratings is not implied. Exposure to absolute maximum rating conditions may affect device reliability.

Table 46. Absolute Maximum Ratings

Item	Rating
Supply Voltage, V_{DD_V}	3.6V
Inputs	-0.5V to $V_{DD_V} + 0.5V$
Outputs, V_O (LVCMOS)	-0.5V to $V_{DD_V} + 0.5V$
Outputs, I_O (LVPECL) Continuous Current Surge Current	50mA 100mA
Outputs, I_O (LVDS) Continuous Current Surge Current	50mA 100mA
Input termination current, I_{VT}	$\pm 35mA$
Operating Junction Temperature, T_J	125°C
Storage Temperature, T_{STG}	-65°C to 150°C
ESD - Human Body Model ^[a]	2000V
ESD - Charged Device Model ^[a]	500V

[a] According to JEDEC JS-001-2012/JESD22-C101

Pin Characteristics

Table 47. Pin Characteristics, $V_{DD_V} = 3.3V \pm 5\%$, $T_A = -40^\circ C$ to $+85^\circ C$

Symbol	Parameter	Test Condition	Minimum	Typical	Maximum	Unit
$C_{IN}^{[a]}$	Input Capacitance	OSC, nOSC		2	4	pF
		other inputs		2	4	pF
R_{PU}	Input Pull-Up Resistor	SDAT, nCS, nCLK_n		51		k Ω
R_{PD}	Input Pull-Down Resistor	EXT_SYS, SCLK, CLK_n, nCLK_n		51		k Ω
R_{OUT}	LVCMOS Output Impedance	nINT, LOCK		25		Ω

[a] Guaranteed by design

DC Characteristics

Table 48. Power Supply DC Characteristics, $V_{DD_V} = 3.3V \pm 5\%$, $T_A = -40^\circ C$ to $+85^\circ C$ ^[a]

Symbol	Parameter	Test Condition	Minimum	Typical	Maximum	Units
V_{DD_V}	Core Supply Voltage		3.135	3.3	3.465	V
I_{DD_TOT}	Total Power Supply Current	See Table 49, Test case 2		913	1031	mA

[a] Electrical parameters are guaranteed over the specified ambient operating temperature range, which is established when the device is mounted in a test socket with maintained transverse airflow greater than 500 lfpm. The device will meet specifications after thermal equilibrium has been reached under these conditions.

Table 49. Typical Power Supply DC Current Characteristics, $V_{DD_V} = 3.3V \pm 5\%$, $T_A = -40^\circ C$ to $+85^\circ C$ ^{[a] [b]}

Symbol	Supply Pin Current		Test Case						Unit
			1	2	3	4	5	6	
All QCLK at LVPECL terminate with 50Ω, NA=4, NC=1, ND=4, NE=8, QREF_XX enable at 7.68MHz	QCLK_y	Style	LVPECL	LVPECL	LVPECL	LVPECL	LVDS	LVDS	
		State	On	On	On	On	On	On	
		Amplitude	500	750	1000	250	500	750	mV
	QREF_r	Style	LVDS	LVDS	LVDS	LVDS	LVDS	LVDS	
		State	On	On	Off	On	Off	Off	
		Amplitude	500	500	–	250	–	–	mV
I_{DD_CA}	Current through VDD_QCLKA pin		85.0	101.0	113.0	75.0	69.0	85.0	mA
I_{DD_CB}	Current through VDD_QCLKB pin		89.0	101.0	112.0	79.0	69.0	85.0	mA
I_{DD_CC}	Current through VDD_QCLKC pin		64.0	69.0	75.0	58.0	53.0	61.0	mA
I_{DD_CD}	Current through VDD_QCLKD pin		60.0	66.0	72.0	55.0	49.0	57.0	mA
I_{DD_CE}	Current through VDD_QCLKE pin		91.0	102.0	113.0	80.0	69.0	85.0	mA
I_{DD_RA}	Current through VDD_QREFA0-2 pins		77.3	77.1	0.0	55.7	0.0	0.0	mA
I_{DD_RB}	Current through VDD_QREFB0-1 pins		51.2	51.3	0.0	36.9	0.0	0.0	mA
I_{DD_RC}	Current through VDD_QREFC pins		27.3	25.3	0.0	20.9	0.0	0.0	mA
I_{DD_RD}	Current through VDD_QREFD pin		26.1	25.9	0.0	18.7	0.0	0.0	mA
I_{DD_INP}	Current through VDD_INP pin		68.0	69.0	69.0	68.0	69.0	69.0	mA
I_{DD_SPI}	Current through VDD_SPI pin		7.0	7.0	7.0	7.0	8.0	8.0	mA
I_{DD_QCLKV}	Current through VDD_QCLKV pins		31.0	31.0	31.0	31.0	31.0	31.0	mA
I_{DD_SYNC}	Current through VDD_SYNC pin		91.0	91.0	31.0	91.0	31.0	31.0	mA
I_{DD_CPF}	Current through VDD_CPF pin		86.0	86.0	87.0	86.0	85.0	85.0	mA
I_{DD_LCV}	Current through VDD_LCV		98.0	98.0	98.0	98.0	99.0	98.0	mA
I_{DD_LCF}	Current through VDD_LCF pin		58.0	58.0	58.0	58.0	59.0	59.0	mA
P_{TOT}	Total Device Power Consumption		2.93	3.01	2.31	2.68	2.28	2.49	W
$P_{TOT, SYS}$	Total System Power Consumption ^[c]		3.33	3.49	2.86	3.03	2.28	2.49	W

[a] f_{CLK} (input) = 122.88MHz, $f_{SYSREF} = 7.68MHz$, internal SYSREF generation (continuous). Supply current is independent on the output frequency configuration used for this table: QA[1:0] = 1966.08MHz, QB[1:0] = 983.04MHz, QC = 3932.16MHz, QD = 983.04MHz, QE[1:0] = 491.52MHz. QCLK_y outputs terminated according to amplitude settings. QREF_r outputs unterminated when SYSREF is turned off.

[b] Electrical parameters are guaranteed over the specified ambient operating temperature range, which is established when the device is mounted in a test socket with maintained transverse airflow greater than 500 lfm. The device will meet specifications after thermal equilibrium has been reached under these conditions.

[c] Includes total device power consumption and the power dissipated in external output termination components.

Table 50. LVC MOS DC Characteristics, $V_{DD_V} = 3.3V \pm 5\%$, $T_A = -40^\circ C$ to $+85^\circ C$ ^[a]

Symbol	Parameter		Test Conditions	Minimum	Typical	Maximum	Units
SYSREF Trigger Input EXT_SYS (1.8V/3.3V Selectable Logic)							
V_{IH}	Input High Voltage			1.17		V_{DD_V}	V
V_{IL}	Input Low Voltage			-0.3		0.63	V
I_{IH}	Input High Current	Input with pull-down resistor	$V_{DD_V} = 3.3V, V_{IN} = 1.8V$ or $3.3V$			150	μA
I_{IL}	Input Low Current		$V_{DD_V} = 3.3V, V_{IN} = 0V$	-5			μA
SPI Inputs SDAT (when input), SCLK, nCS (1.8V/3.3V selectable logic with input hysteresis)							
V_I	Input Voltage			-0.3		V_{DD_V}	V
V_{T+}	Positive-going input threshold voltage		1.8V logic (SELSV0 = 0)	0.660		1.350	V
			3.3V logic (SELSV0 = 1)		1.8-2.1		V
V_{T-}	Negative-going input threshold voltage		1.8V logic (SELSV0 = 0)	0.495		1.170	V
			3.3V logic (SELSV0 = 1)		0.75-0.97		V
V_H	Hysteresis Voltage		$V_{T+} - V_{T-}$	0.165		0.780	V
SPI output DAT (when output), SDO, nINT, LOCK (1.8V/3.3V selectable logic)							
V_{OH}	Output High Voltage		1.8V logic (SELSV = 0) $I_{OH} = -4mA$	1.35			V
			3.3V logic (SELSV = 1) $I_{OH} = -4mA$	2.4			V
V_{OL}	Output Low Voltage		1.8V logic (SELSV = 0) $I_{OL} = 4mA$			0.45	V
			3.3V logic (SELSV = 1) $I_{OL} = 4mA$			0.4	V

[a] Electrical parameters are guaranteed over the specified ambient operating temperature range, which is established when the device is mounted in a test socket with maintained transverse airflow greater than 500 lfm. The device will meet specifications after thermal equilibrium has been reached under these conditions.

Table 51. Differential Input DC Characteristics, $V_{DD_V} = 3.3V \pm 5\%$, $T_A = -40^\circ C$ to $+85^\circ C$ ^[a]

Symbol	Parameter		Test Conditions	Minimum	Typical	Maximum	Units
I_{IH}	Input High Current	Inputs with pull-down resistor ^[b]	$V_{DD_V} = V_{IN} = 3.465V$			150	μA
		Pull-down/pull-up inputs ^[c]				150	μA
I_{IL}	Input Low Current	Inputs with pull-down resistor	$V_{DD_V} = 3.465V, V_{IN} = 0V$	-50			μA
		Pull-down/pull-up inputs		-150			μA

[a] Electrical parameters are guaranteed over the specified ambient operating temperature range, which is established when the device is mounted in a test socket with maintained transverse airflow greater than 500 lfm. The device will meet specifications after thermal equilibrium has been reached under these conditions.

[b] Non-Inverting inputs: CLK_n, OSC

[c] Inverting inputs: nCLK_n, nOSC

Table 52. LVPECL DC Characteristics (QCLK_y, QREF_r, STYLE = 1), $V_{DD_V} = 3.3V \pm 5\%$, $T_A = -40^\circ C$ to $+85^\circ C$ ^[a]

Symbol	Parameter	Test Conditions	Minimum	Typical	Maximum	Units
V_{OH}	Output High Voltage ^[b]	250mV Amplitude Setting	$V_{DD_V} - 1.027$	$V_{DD_V} - 0.838$	$V_{DD_V} - 0.750$	V
		500mV Amplitude Setting	$V_{DD_V} - 1.041$	$V_{DD_V} - 0.857$	$V_{DD_V} - 0.708$	V
		750mV Amplitude Setting	$V_{DD_V} - 1.054$	$V_{DD_V} - 0.876$	$V_{DD_V} - 0.755$	V
		1000mV Amplitude Setting	$V_{DD_V} - 1.078$	$V_{DD_V} - 0.898$	$V_{DD_V} - 0.777$	V
V_{OL}	Output Low Voltage	250mV Amplitude Setting	$V_{DD_V} - 1.311$	$V_{DD_V} - 1.138$	$V_{DD_V} - 0.949$	V
		500mV Amplitude Setting	$V_{DD_V} - 1.575$	$V_{DD_V} - 1.421$	$V_{DD_V} - 1.212$	V
		750mV Amplitude Setting	$V_{DD_V} - 1.842$	$V_{DD_V} - 1.703$	$V_{DD_V} - 1.493$	V
		1000mV Amplitude Setting	$V_{DD_V} - 2.119$	$V_{DD_V} - 1.983$	$V_{DD_V} - 1.746$	V

[a] Electrical parameters are guaranteed over the specified ambient operating temperature range, which is established when the device is mounted in a test socket with maintained transverse airflow greater than 500 lfm. The device will meet specifications after thermal equilibrium has been reached under these conditions.

[b] Outputs terminated with 50Ω to $V_{DD_V} - 1.5V$ (250mV amplitude setting), $V_{DD_V} - 1.75V$ (500mV amplitude setting), $V_{DD_V} - 2.0V$ (750mV amplitude setting), $V_{DD_V} - 2.25V$ (1000mV amplitude setting)

Table 53. LVDS DC Characteristics (QCLK_y, QREF_r, STYLE = 0), $V_{DD_V} = 3.3V \pm 5\%$, $T_A = -40^\circ C$ to $+85^\circ C$ ^[a]

Symbol	Parameter	Test Conditions	Minimum	Typical	Maximum	Units
V_{OS}	Offset Voltage ^[b]	250mV Amplitude Setting	2.05	2.37	2.70	V
		500mV Amplitude Setting	1.90	2.21	2.55	V
		750mV Amplitude Setting	1.75	2.06	2.39	V
		1000mV Amplitude Setting	1.60	1.91	2.20	V
ΔV_{OS}	V_{OS} Magnitude Change			50	mV	

[a] Electrical parameters are guaranteed over the specified ambient operating temperature range, which is established when the device is mounted in a test socket with maintained transverse airflow greater than 500 lfm. The device will meet specifications after thermal equilibrium has been reached under these conditions.

[b] V_{OS} changes with V_{DD_V}

AC Characteristics

Table 54. AC Characteristics, $V_{DD,V} = 3.3V \pm 5\%$, $T_A = -40^\circ C$ to $+85^\circ C$ [a][b]

Symbol	Parameter		Test Conditions	Minimum	Typical	Maximum	Unit
f_{OUT}	Output Frequency		QCLK_y, QREF_r (Clock), N = ÷1		3932.16		MHz
			QCLK_y, QREF_r (Clock), N = ÷2		1966.08		MHz
			QCLK_y, QREF_r (Clock), N = ÷4		983.04		MHz
			QCLK_y, QREF_r (Clock), N = ÷8		491.52		MHz
			QCLK_y, QREF_r (Clock), N = ÷16		245.76		MHz
			QCLK_y, QREF_r (Clock), N = ÷32		122.88		MHz
			QREF_r (SYSREF)	0.3072		61.44	MHz
f_{VCO}	VCO Frequency				3932.16		MHz
f_{CLK}	Input Frequency		CLK_n	30.72	245.76	2000	MHz
f_{VCXO}	VCXO Frequency			30.72	122.88	500	MHz
Δ_{fp}	Static Frequency Error		$f_{CLK} = 0$ ppb frequency deviation			0	ppb
Δ_{fms}	Dynamic Frequency Error RMS ^[c]		$f_{CLK} = 0$ ppb frequency deviation			0.5	ppb
V_{IN}	Input Voltage Amplitude ^[d]	CLK_n, OSC/nOSC		0.15		1.2	V
V_{DIFF_IN}	Differential Input Voltage Amplitude ^{[d], [e]}	CLK_n, OSC/nOSC		0.3		2.4	V
V_{CMR}	Common Mode Input Voltage			1.0		$V_{DD,V} - (V_{IN} / 2)$	V
odc	Output Duty Cycle		QCLK_y, QREF_r (Clock)	45	50	55	%
t_R / t_F	Output Rise/Fall Time, Differential		QCLK_y, QREF_r (LVPECL), 20% to 80%		115	250	ps
			QCLK_y, QREF_r (LVDS), 20% to 80%		120	250	ps
			QREF_r (SYSREF, LVDS), 20% to 80%		130	250	ps
	Output Rise/Fall Time		LVC MOS outputs, 20%-80%			1	ns
$V_{O(PP)}$ ^[f]	LVPECL Output Voltage Swing, Peak-to-peak	250mV Amplitude	1966.08MHz 491.52MHz	225 240	273 273	335 315	mV
		500mV Amplitude	1966.08MHz 491.52MHz	430 450	498 505	600 580	mV
		750mV Amplitude	1966.08MHz 491.52MHz	625 670	708 744	840 850	mV
		1000mV Amplitude	1966.08MHz 491.52MHz	800 890	887 984	1050 1100	mV
	LVPECL Differential Output Voltage Swing, Peak-to-peak	250mV Amplitude	1966.08MHz 491.52MHz	450 480	546 546	670 630	mV
		500mV Amplitude	1966.08MHz 491.52MHz	860 900	996 1010	1200 1160	mV
		750mV Amplitude	1966.08MHz 491.52MHz	1250 1340	1416 1488	1680 1700	mV
		1000mV Amplitude	1966.08MHz 491.52MHz	1600 1780	1774 1968	2100 2200	mV

Table 54. AC Characteristics, $V_{DD,V} = 3.3V \pm 5\%$, $T_A = -40^\circ C$ to $+85^\circ C$ (Cont.)^{[a][b]}

Symbol	Parameter		Test Conditions	Minimum	Typical	Maximum	Unit
$V_{OD}^{[g]}$	LVDS Output Voltage Swing, Peak-to-peak	250mV Amplitude	1966.08MHz 491.52MHz	154 210	208 233	247 259	mV
		500mV Amplitude	1966.08MHz 491.52MHz	339 442	432 475	498 515	mV
		750mV Amplitude	1966.08MHz 491.52MHz	501 672	642 713	738 752	mV
		1000mV Amplitude	1966.08MHz 491.52MHz	621 814	818 954	955 1014	mV
	LVDS Differential Output Voltage Swing, Peak-to-peak	250mV Amplitude	1966.08MHz 491.52MHz	308 420	416 466	495 518	mV
		500mV Amplitude	1966.08MHz 491.52MHz	678 884	864 950	997 1030	mV
		750mV Amplitude	1966.08MHz 491.52MHz	1002 1342	1284 1426	1476 1504	mV
		1000mV Amplitude	1966.08MHz 491.52MHz	1242 1628	1636 1908	1911 2029	mV
Δt_{PD}	Propagation delay variation between reference input and any QCLK_y output			-200		+200	ps
$t_{sk(o)}$	Output Skew ^{[h][i]} ; All delays set to 0		QCLK_y (same N divider)		20	100	ps
			QCLK_y (any N divider, incident rising edge)		30	100	ps
			QREF_r (Clock)		20	100	ps
			QREF_r (SYSREF)		25	100	ps
			QREF_r (Clock) to QCLK_y (any divider, incident rising QCLK edge)		92	150	ps
			QREF_r (SYSREF) to QCLK_y (any divider, incident rising QCLK edge)		20	100	ps
Δf	Output isolation between any neighboring clock output	$f_{OUT} = 614.4MHz$		65	70		dB
		$f_{OUT} = 245.76MHz$		70	80		dB
Δf	Output isolation between any QCLK_y, QREF_r (SYSREF ^[j]) output	Both SYSREF and clock signals active		50	60		dB
$t_{D, LOS}$	LOS state detected (measured in input reference periods)	$f_{CLK} = 122.88MHz$ or $245.76MHz$				2	T_{IN}
$t_{D, LOCK}$	PLL lock detect	PLL re-lock time after a short-term holdover scenario. Measured from LOS to both PLLs lock-detect asserted; hold-off timer = 200msecs, VCXO-PLL bandwidth = 10Hz, initial frequency error <200 ppm.			200	300	ms
$t_{D, RES}$	PLL lock residual time error	Refer to PLL lock detect $t_{D, LOCK}$. Reference point: final value of clock output phase after all phase transitions settled.			0.025	20	ns

Table 54. AC Characteristics, $V_{DD_V} = 3.3V \pm 5\%$, $T_A = -40^\circ C$ to $+85^\circ C$ (Cont.)^{[a][b]}

Symbol	Parameter	Test Conditions	Minimum	Typical	Maximum	Unit
Δf_{HOLD}	Holdover accuracy	Max. frequency deviation during a holdover duration of 200ms and after the clock re-validate event.		0.2	± 5	ppm
$t_{D, RES-H}$	Holdover residual error.	Measured 50ms after the reference clock re-appeared in a holdover scenario. Reference point: final value of clock output phase after all phase transitions settled.		3	± 8.138	ns
t_{H_E}	Hold Time	EXT_SYS to CLK_n	-3			ns
t_{S_E}	Setup Time	EXT_SYS to CLK_n	-0.5			ns
t_{W_E}	Pulse Width	EXT_SYS	2			ns
t_{H_C}	Hold Time	CLK_1 to CLK_n	-3			ns
t_{S_C}	Setup Time	CLK_1 to CLK_n	-3			ns
t_{W_C}	Pulse Width	CLK_1	2			ns

[a] Electrical parameters are guaranteed over the specified ambient operating temperature range, which is established when the device is mounted in a test socket with maintained transverse airflow greater than 500 lpm. The device will meet specifications after thermal equilibrium has been reached under these conditions.

[b] VCXO-PLL bandwidth = 10Hz.

[c] RMS frequency error, measured at any QCLK_y output, caused by Gaussian noise. Weighted with a 1ms low pass time window filter.

[d] V_{IL} should not be less than -0.3V and V_{IH} should not be greater than V_{DD_V}

[e] Common Mode Input Voltage is defined as the cross-point voltage.

[f] LVPECL outputs terminated with 50Ω to $V_{DD_V} - 1.5V$ (250mV amplitude setting), $V_{DD_V} - 1.75V$ (500mV amplitude setting), $V_{DD_V} - 2.0V$ (750mV amplitude setting), $V_{CCO} - 2.25V$ (1000mV amplitude setting)

[g] LVDS outputs terminated 100Ω across terminals

[h] This parameter is defined in accordance with JEDEC standard 65

[i] Defined as skew between outputs at the same supply voltage and with equal load conditions. Measured at the differential cross points

[j] SYSREF frequencies: 15.36, 7.68, 3.84MHz

Table 55. Clock Phase Noise Characteristics, $V_{DD_V} = 3.3V \pm 5\%$, $T_A = -40^\circ C$ to $+85^\circ C$ ^{[a][b][c]}

Symbol	Parameter	Test Condition	Minimum	Typical	Maximum	Unit
$f_{jit}(\emptyset)$	Clock RMS Phase Jitter (Random), 3932.16MHz	Integration Range: 1kHz – 76.8MHz		52	65	fs
		Integration Range: 12kHz – 20MHz		46	60	fs
$\Phi_N(10)$	Clock Single-side Band Phase Noise 3932.16MHz	10Hz offset (determined by VCXO)		-58.7	-55.3	dBc/Hz
$\Phi_N(100)$		100Hz offset (determined by VCXO)		-86.4	-82.3	dBc/Hz
$\Phi_N(1k)$		1kHz offset from carrier		-110.2	-108.1	dBc/Hz
$\Phi_N(10k)$		10kHz offset from carrier		-117.5	-115.6	dBc/Hz
$\Phi_N(100k)$		100kHz offset from carrier		-120.3	-118.5	dBc/Hz
$\Phi_N(1M)$		1MHz offset from carrier		-127.9	-125.7	dBc/Hz
$\Phi_N(\geq 10M)$		$\geq 10MHz$ offset from carrier and noise floor			-148.9	-146.9

Table 55. Clock Phase Noise Characteristics, $V_{DD_V} = 3.3V \pm 5\%$, $T_A = -40^\circ C$ to $+85^\circ C$ (Cont.)^{[a][b][c]}

Symbol	Parameter	Test Condition	Minimum	Typical	Maximum	Unit	
$\Phi_N(10)$	Clock Single-side Band Phase Noise	1966.08MHz	10Hz offset (determined by VCXO)		-63.7	-60.1	dBc/Hz
$\Phi_N(100)$			100Hz offset (determined by VCXO)		-92.3	-89.3	dBc/Hz
$\Phi_N(1k)$			1kHz offset from carrier		-115.9	-114.6	dBc/Hz
$\Phi_N(10k)$			10kHz offset from carrier		-124.0	-122.1	dBc/Hz
$\Phi_N(100k)$			100kHz offset from carrier		-126.7	-125.1	dBc/Hz
$\Phi_N(1M)$			1MHz offset from carrier		-134.5	-132.3	dBc/Hz
$\Phi_N(\geq 10M)$			≥ 10 MHz offset from carrier and noise floor		-150.6	-149.8	dBc/Hz
$\Phi_N(10)$	Clock Single-side Band Phase Noise	983.04MHz	10Hz offset (determined by VCXO)		-70.4	-68	dBc/Hz
$\Phi_N(100)$			100Hz offset (determined by VCXO)		-97.6	-95.1	dBc/Hz
$\Phi_N(500)$			500Hz offset from carrier		-116.5	-114	dBc/Hz
$\Phi_N(1k)$			1kHz offset from carrier		-122.4	-119.3	dBc/Hz
$\Phi_N(10k)$			10kHz offset from carrier		-129.6	-127.8	dBc/Hz
$\Phi_N(60k)$			60kHz offset from carrier		-131.3	-129.7	dBc/Hz
$\Phi_N(100k)$			100kHz offset from carrier		-132.3	-130.7	dBc/Hz
$\Phi_N(200k)$			200kHz offset from carrier		-133.5	-131.8	dBc/Hz
$\Phi_N(800k)$			800kHz offset from carrier		-138.6	-136	dBc/Hz
$\Phi_N(5M)$			5MHz offset from carrier		-151.5	-149.1	dBc/Hz
$\Phi_N(\geq 10M)$			≥ 10 MHz offset from carrier and noise floor		-154.0	-152.4	dBc/Hz
$\Phi_N(10)$			Clock Single-side Band Phase Noise	245.76MHz	10Hz offset (determined by VCXO)		-82.6
$\Phi_N(100)$	100Hz offset (determined by VCXO)				-109.9	-106.5	dBc/Hz
$\Phi_N(500)$	500Hz offset from carrier				-126.8	-124.7	dBc/Hz
$\Phi_N(1k)$	1kHz offset from carrier				-131.8	-128.9	dBc/Hz
$\Phi_N(10k)$	10kHz offset from carrier				-140.5	-139.5	dBc/Hz
$\Phi_N(60k)$	60kHz offset from carrier				-143.5	-141.8	dBc/Hz
$\Phi_N(100k)$	100kHz offset from carrier				-144.5	-142.5	dBc/Hz
$\Phi_N(200k)$	200kHz offset from carrier				-145.7	-143.7	dBc/Hz
$\Phi_N(800k)$	800kHz offset from carrier				-150.5	-148.2	dBc/Hz
$\Phi_N(5M)$	5MHz offset from carrier				-159.2	-157.3	dBc/Hz
$\Phi_N(\geq 10M)$	≥ 10 MHz offset from carrier and noise floor				-160.2	-158.9	dBc/Hz

Table 55. Clock Phase Noise Characteristics, $V_{DD_V} = 3.3V \pm 5\%$, $T_A = -40^\circ C$ to $+85^\circ C$ (Cont.)^{[a][b][c]}

Symbol	Parameter		Test Condition	Minimum	Typical	Maximum	Unit
Φ	Spurious Signals (QCLK, QREF as clock)	3932.16MHz	100Hz – 300Hz		-65.4	-57.8	dBc
			300Hz – 100kHz		-98.7	-92.1	dBc
			100kHz – 100MHz		-97.4	-92.2	dBc
		983.04MHz	100Hz – 300Hz		-78.9	-73.7	dBc
			300Hz – 100kHz		-110.8	-106.7	dBc
			100kHz – 100MHz		-99.6	-94.8	dBc
		245.76MHz	100Hz – 300Hz		-89.6	-85.2	dBc
			300Hz – 100kHz		-117.1	-113.2	dBc
			100kHz – 100MHz		-99.5	-93.4	dBc

[a] Phase noise and spurious specifications apply for device operation with QREF_r outputs inactive (no SYSREF pulses generated). Phase noise specifications are applicable for all outputs active, Nx not equal.

[b] Electrical parameters are guaranteed over the specified ambient operating temperature range, which is established when the device is mounted in a test socket with maintained transverse airflow greater than 500lfpm. The device will meet specifications after thermal equilibrium has been reached under these conditions.

[c] Phase noise characteristics at lower frequency offsets (10Hz ~1kHz) is primarily a function of the VCXO phase noise: VCXO characteristics: f = 122.88MHz; phase noise: -80.9dBc/Hz (10Hz), -106.3dBc/Hz (100Hz), -128.8dBc/Hz (1kHz), -144.8dBc/Hz (10kHz), -150.9dBc/Hz (100kHz):.

Table 56. SYSREF Phase Noise Characteristics, $V_{DD_V} = 3.3V \pm 5\%$, $T_A = -40^\circ C$ to $+85^\circ C$ ^{[a][b]}

Symbol	Parameter		Test Conditions	Minimum	Typical	Maximum	Unit
$\Phi_N(500)$	SYSREF single-side band phase noise	30.72MHz	500Hz offset		-131.2	-129	dBc/Hz
$\Phi_N(10k)$			10kHz offset from Carrier		-146.5	-148.1	dBc/Hz
$\Phi_N(60k)$			60kHz offset from Carrier		-154.3	-150.2	dBc/Hz
$\Phi_N(800k)$			800kHz offset from Carrier		-157.8	-152.2	dBc/Hz
$\Phi_N(\geq 3M)$			≥ 3 MHz offset from Carrier and Noise Floor		-157.1	-152.1	dBc/Hz
Φ	Spurious signals ^[c]	3.84MHz	> 500Hz		-60.0	-56	dBc
		15.36MHz	> 500Hz		-62.6	-59	dBc
		7.68MHz	> 500Hz		-62.6	-59	dBc

[a] Phase noise is measured as additive phase noise contribution by the device on all SYSREF outputs, dividers and channel logic. SYSREF signals measured as continued clock signal. Clock signals (QCLK) are turned on.

[b] Electrical parameters are guaranteed over the specified ambient operating temperature range, which is established when the device is mounted in a test socket with maintained transverse airflow greater than 500 lfpm. The device will meet specifications after thermal equilibrium has been reached under these conditions.

[c] Measured as sum of all spurious amplitudes in one side band in the offset frequency range above 500Hz, excluding the harmonics of the fundamental frequency of $n \times f_{SYSREF}$ (e.g. $n \times 7.68$ MHz).

Table 57. AC Characteristics: Typical QCLK_y Output Amplitude, $V_{DD_V} = 3.3V$, $T_A = 25^{\circ}C$ ^[a]

Symbol	Parameter	Test Conditions	QCLK_y Output Frequency in MHz				Unit
			3932.16	1966.08	983.04	491.52	
$V_{O(PP)}$ ^[b]	LVPECL Output Voltage Swing, Peak-to-peak	250mV Amplitude Setting	154	273	276	273	mV
		500mV Amplitude Setting	265	498	515	505	mV
		750mV Amplitude Setting	346	708	754	744	mV
		1000mV Amplitude Setting	407	887	978	984	mV
V_{OD} ^[c]	LVDS Output Voltage Swing, Peak-to-peak	250mV Amplitude Setting	124	208	228	233	mV
		500mV Amplitude Setting	248	432	468	475	mV
		750mV Amplitude Setting	343	642	709	713	mV
		1000mV Amplitude Setting	403	818	936	954	mV

[a] Electrical parameters are guaranteed over the specified ambient operating temperature range, which is established when the device is mounted in a test socket with maintained transverse airflow greater than 500 lfm. The device will meet specifications after thermal equilibrium has been reached under these conditions.

[b] LVPECL outputs terminated with 50Ω to $V_{DD_V} - 1.5V$ (250mV amplitude setting), $V_{DD_V} - 1.75V$ (500mV amplitude setting), $V_{DD_V} - 2.0V$ (750mV amplitude setting), $V_{CCO} - 2.25V$ (1000mV amplitude setting).

[c] LVDS outputs terminated 100Ω across terminals.

Figure 8. EXT_SYS Input Timing Diagram

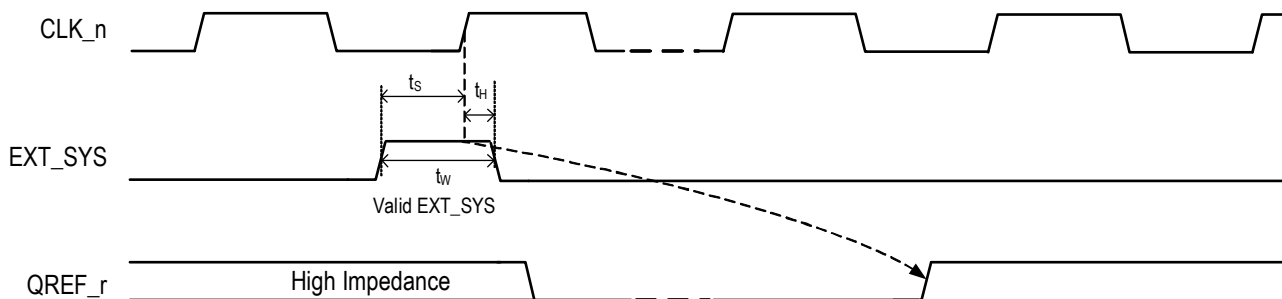

Clock Phase Noise Characteristics

Measurement conditions for phase noise characteristics:

- VCXO characteristics: $f = 122.88\text{MHz}$; phase noise: -80.9dBc/Hz (10Hz), -106.3dBc/Hz (100Hz), -128.8dBc/Hz (1kHz), -144.8dBc/Hz (10kHz), -150.9dBc/Hz (100kHz):
- Input frequency: 122.88MHz
- I_{CPV} VCXO-PLL charge pump current: 0.75mA
- VCXO-PLL bandwidth: 12Hz
- I_{CPF} FemtoClock NG charge pump current: 3.4mA
- FemtoClock NG PLL bandwidth: 100kHz
- $V_{DD_V} = 3.3\text{V}$, $T_A = 25^\circ\text{C}$

Figure 9. VCXO Phase Noise

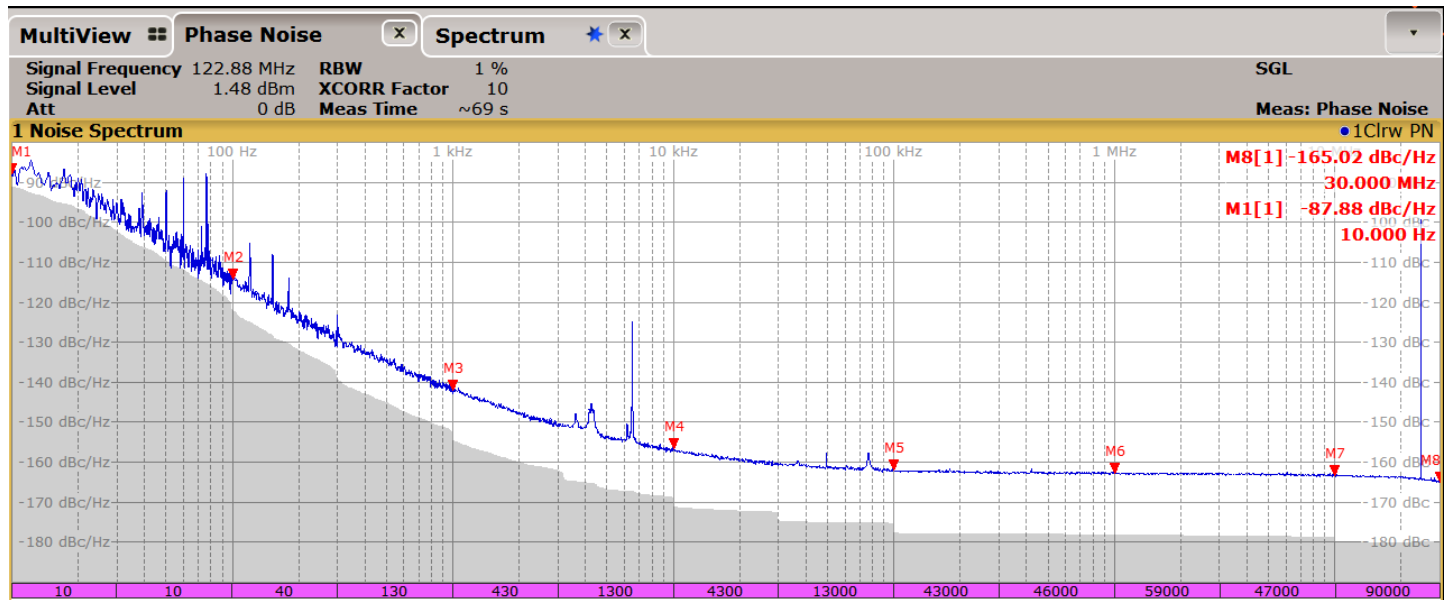

Figure 10. 3932.16MHz Output Phase Noise

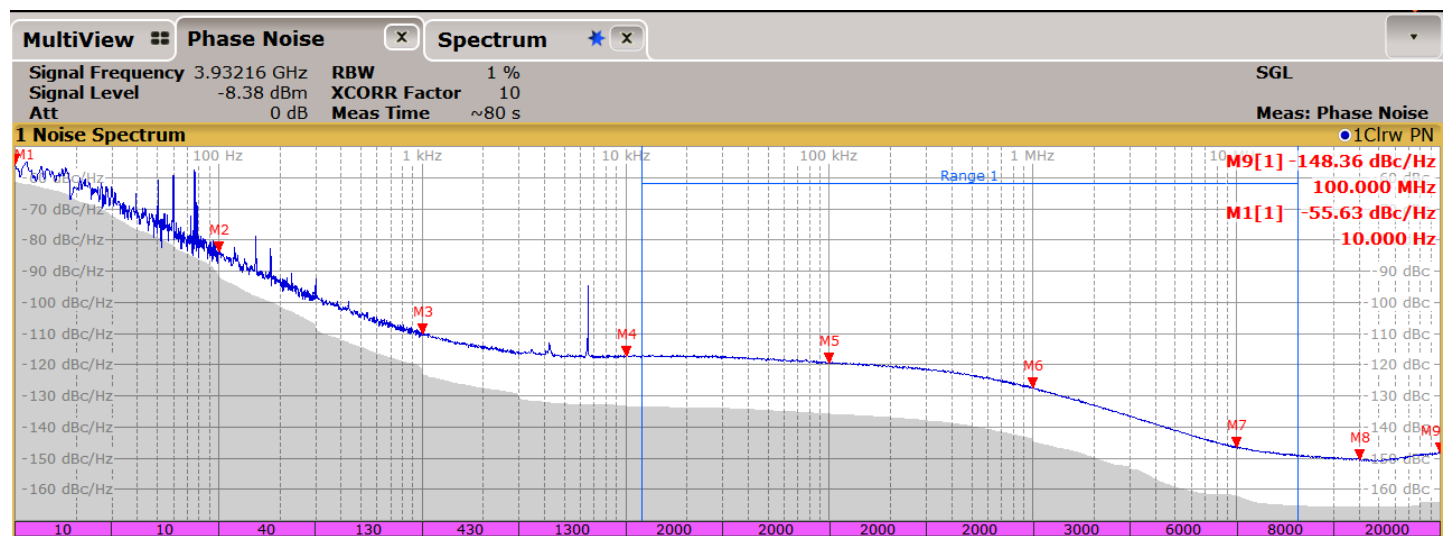

Figure 11. 1966.08MHz Output Phase Noise

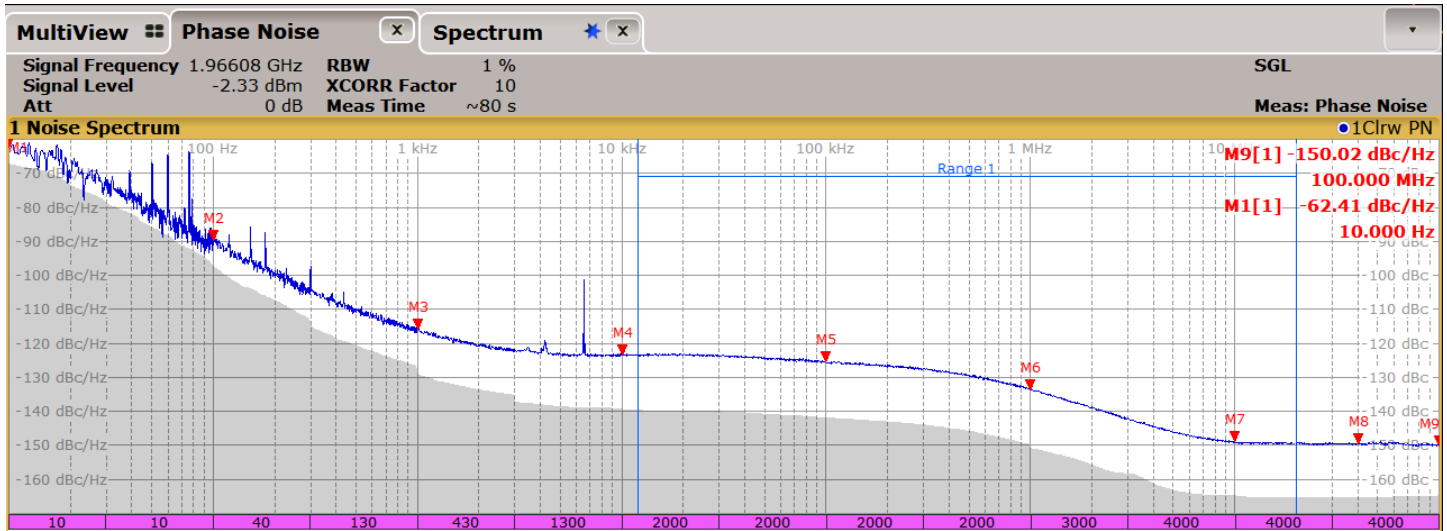

Figure 12. 983.04MHz Output Phase Noise

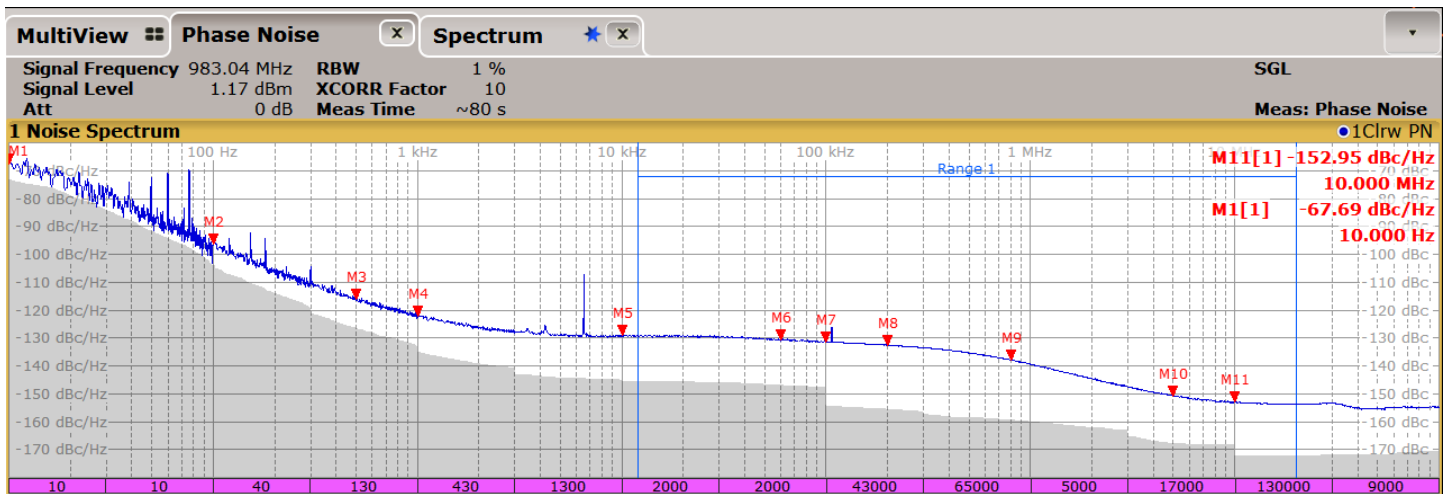
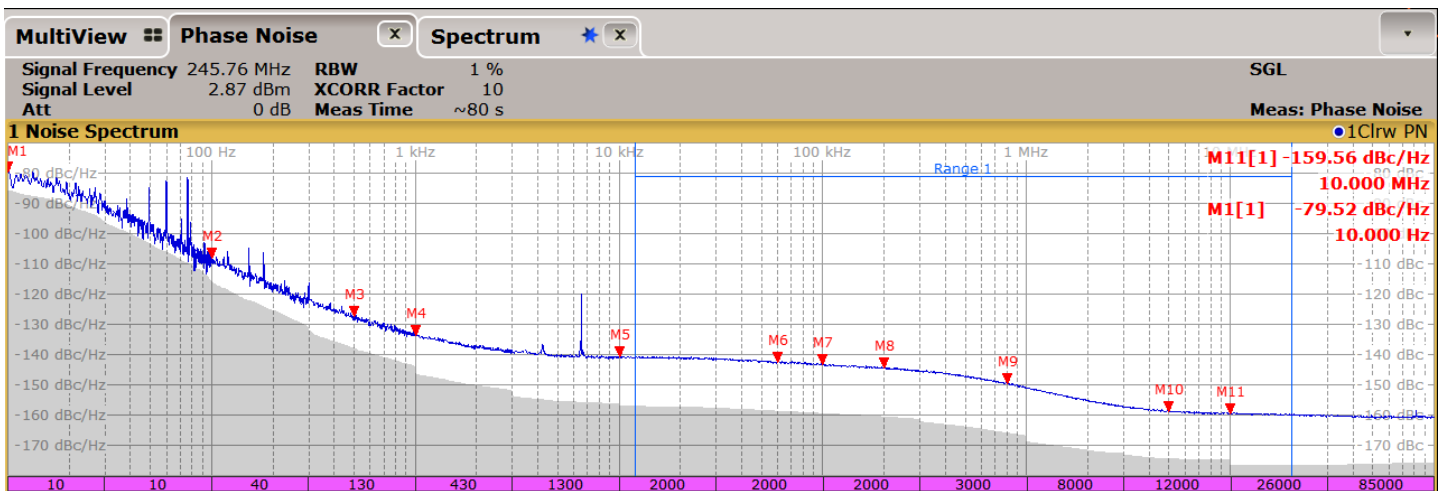

Figure 13. 245.76MHz Output Phase Noise



Application Information

Termination for QCLK_y, QREF_r LVDS Outputs (STYLE = 0)

Figure 14 shows an example termination for the QCLK_y, QREF_r LVDS outputs. In this example, the characteristic transmission line impedance is 50Ω . The termination resistor R (100Ω) is matched to the line impedance. The termination resistor must be placed at the line end. No external termination resistor is required if R is an internal part of the receiver circuit. The LVDS termination in Figure 14 is applicable for any output amplitude setting specified in Table 16.

Figure 14. LVDS (SYLE = 0) Output Termination

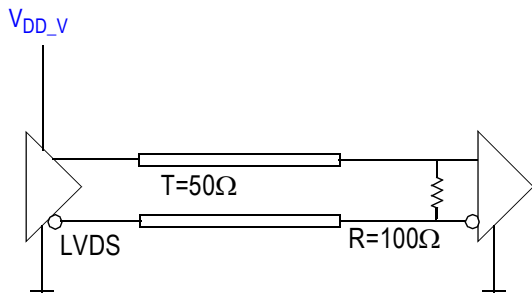

AC Termination for QCLK_y, QREF_r LVDS Outputs (STYLE = 0)

Figure 15 and Figure 16 show example AC terminations for the QCLK_y, QREF_r LVDS outputs. In the examples, the characteristic transmission line impedance is 50Ω . In Figure 15, the termination resistor R (100Ω) is placed at the line end. No external termination resistor is required if R is an internal part of the receiver circuit, which is shown in Figure 16. The LVDS terminations in both Figure 15 and Figure 16 are applicable for any output amplitude setting specified in Table 16. The receiver input should be re-biased according to its common mode range specifications.

Figure 15. LVDS (SYLE = 0) AC Output Termination

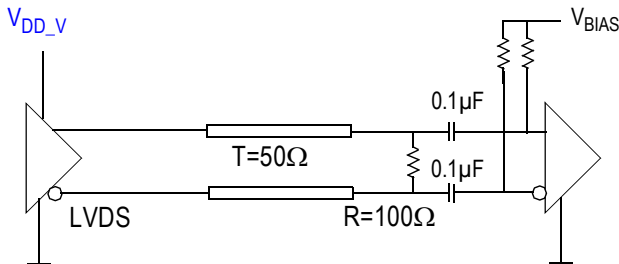
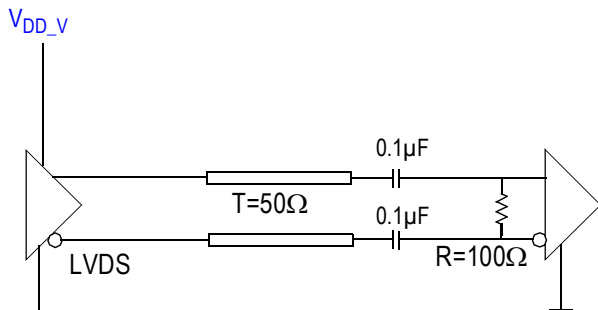

Figure 16. LVDS (SYLE = 0) AC Output Termination



Termination for QCLK_y, QREF_r LVPECL Outputs (STYLE = 1)

Figure 17 shows an example termination for the QCLK_y, QREF_r LVPECL outputs. In this example, the characteristic transmission line impedance is 50Ω. The R1 (50Ω) and R2 (50Ω) resistors are matched load terminations. The output is terminated to the termination voltage V_T. The V_T must be set according to the output amplitude setting defined in Table 16. The termination resistors must be placed close at the line end.

Figure 17. LVPECL (STYLE = 1) Output Termination

$$V_T = V_{DD_V} - 1.50V \text{ (250mV Amplitude)}$$

$$V_T = V_{DD_V} - 1.75V \text{ (500mV Amplitude)}$$

$$V_T = V_{DD_V} - 2.00V \text{ (750mV Amplitude)}$$

$$V_T = V_{DD_V} - 2.25V \text{ (1000mV Amplitude)}$$

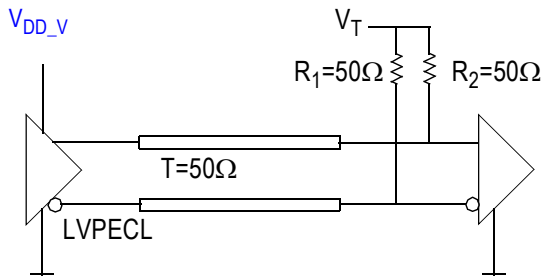

Thermal Characteristics

The 8V19N492-39 is a multi-functional, high-speed device that targets a wide variety of clock frequencies and applications. Since this device is highly programmable with a broad range of features and functionality, the power consumption will vary as each of these features and functions is enabled. The device was designed and characterized to operate within the industrial temperature range of -40°C to +85°C. The ambient temperature represents the temperature around the device, not the junction temperature. When using the device in extreme cases, such as maximum operating frequency and high ambient temperature, external air flow may be required in order to ensure a safe and reliable junction temperature. Extreme care must be taken to avoid exceeding 125°C junction temperature. For any concerns on calculating the power dissipation for your own specific configuration, please contact Renesas technical support.

Table 58. Thermal Resistance^[a]

Symbol	Thermal Parameter	Condition	Value	Unit
Θ _{JA}	Junction to Ambient	0 m/s air flow	17.2	°C/W
		1 m/s air flow	16.1	°C/W
		2 m/s air flow	15.6	°C/W
Θ _{JC}	Junction to Case		22.6	°C/W
Θ _{JB}	Junction to Board		0.9	°C/W

[a] Standard JEDEC 2S2P multilayer PCB.

Case Temperature Considerations

The 8V19N492-39 supports applications in a natural convection environment that does not have any thermal conductivity through ambient air. The PCB is typically in a sealed enclosure without any natural or forced air flow and is kept at or below a specific temperature. The device package design incorporates an exposed pad (ePad) with enhanced thermal parameters that is soldered to the PCB where most of the heat escapes from the bottom exposed pad. For this type of application, it is recommended to use the junction-to-board thermal characterization parameter Ψ_{JB} (Psi-JB) to calculate the junction temperature (T_J) and ensure it does not exceed the maximum allowed junction temperature in [Absolute Maximum Ratings](#).

The junction-to-board thermal characterization parameter, Ψ_{JB} , is calculated using the following equation:

$$T_J = T_{CB} + \Psi_{JB} \times P_D, \text{ where}$$

T_J = Junction temperature at steady state condition in ($^{\circ}\text{C}$).

T_{CB} = Case temperature (Bottom) at steady state condition in ($^{\circ}\text{C}$).

Ψ_{JB} = Thermal characterization parameter to report the difference between junction temperature and the temperature of the board measured at the top surface of the board.

P_D = Power dissipation (W) in desired operating configuration.

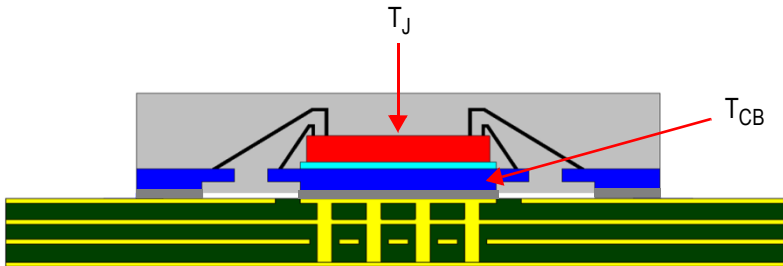

The ePad provides a low thermal resistance path for heat transfer to the PCB and represents the key pathway to transfer heat away from the IC to the PCB. It is critical that the connection of the exposed pad to the PCB is properly constructed to maintain the desired IC case temperature (T_{CB}). A good connection ensures that temperature at the exposed pad (T_{CB}) and the board temperature (T_B) are relatively the same. An improper connection can lead to increased junction temperature, increased power consumption, and decreased electrical performance. In addition, there could be long-term reliability issues and increased failure rate.

Example Calculation for Junction Temperature (T_J): $T_J = T_{CB} + \Psi_{JB} \times P_D$

$P_D = 3.57\text{W}$ (P_D is calculated from [Table 48](#))

$$T_J = 105^{\circ}\text{C} + 0.7^{\circ}\text{C/W} \times 3.57\text{W} = 107.5^{\circ}\text{C} < 125^{\circ}\text{C}$$

Table 59. Thermal Resistance for 88-VFQFPN Package

Package Type	88-VFQFPN
Body size (mm)	10 × 10 mm
ePad size (mm)	8 × 8 mm ²
Thermal Via	8 × 8 Matrix
Ψ_{JB}	0.7 $^{\circ}\text{C/W}$
T_{CB}	105 $^{\circ}\text{C}$

Package Outline Drawings

The package outline drawings are appended at the end of this document and are accessible from the link below. The package information is the most current data available.

www.idt.com/document/psc/88-vfqfpn-package-outline-drawing100-x-100-x-085-mm-body-04mm-pitchepad-810-x-810-mm-nlg88p2

Ordering Information

Orderable Part Number	Package	Shipping Packaging	Temperature
8V19N492-39NLGI	RoHS 6/6 88-VFQFPN, 10x10 mm ²	Tray	-40°C to +85°C
8V19N492-39NLGI8		Tape and Reel	

Marking Diagram

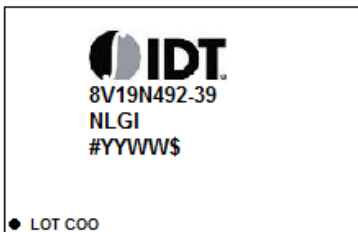

1. Line 1 indicates the part number.
2. Line 2 indicates the part number suffix
2. Line 3:
 - “YYWW” is the last digit of the year and week that the part was assembled.
 - #: denotes sequential lot number.
 - \$: denotes mark code.

Glossary

Abbreviation	Description
Index <i>n</i>	Denominates a clock input CLK_ <i>n</i> . Range: 0 to 1
Index <i>x</i>	Denominates a channel, channel frequency divider and the associated configuration bits. Range: A, B, C, D, E.
Index <i>y</i>	Denominates a QCLK output and associated configuration bits. Range: A0, A1, B0, B1, C, D, E0, E1
Index <i>r</i>	Denominates a QREF output and associated configuration bits. Range: A0, A1, A2, B0, B1, C, D
V _{DD_V}	Denominates voltage supply pins. Range: VDD_QCLKA, VDD_QCLKB, VDD_QCLKC, VDD_QCLKD, VDD_QCLKE, VDD_QREFA0, VDD_QREFA1, VDD_QREFA2, VDD_QREFB0, VDD_QREFB1, VDD_QREFC, VDD_QREFD, VDD_SPI, VDD_QCLKV, VDD_CPV, VDD_INP, VDD_CPF, VDD_LCF, VDD_LCV1, VDD_LCV2, VDD_SYNC
status_condition	Status conditions are: LOLV (Loss of VCXO-PLL lock), LOLF (Loss of FemtoClock NG PLL lock) and LOS (Loss of input signal)
[...]	Index brackets describe a group associated with a logical function or a bank of outputs.
{...}	List of discrete values
Suffix V	Denominates a function associated with the VCXO-PLL
Suffix F	Denominates a function associated with the 2nd stage PLL (FemtoClock NG)

Revision History

Revision Date	Description of Change
December 11, 2020	Replaced incorrect pin name VDD_OSC by VDD_QCLKV and QOSC by QCLK_V to match the pinout diagram.
November 5, 2020	Updated Output Phase Delay
March 27, 2020	Initial release.

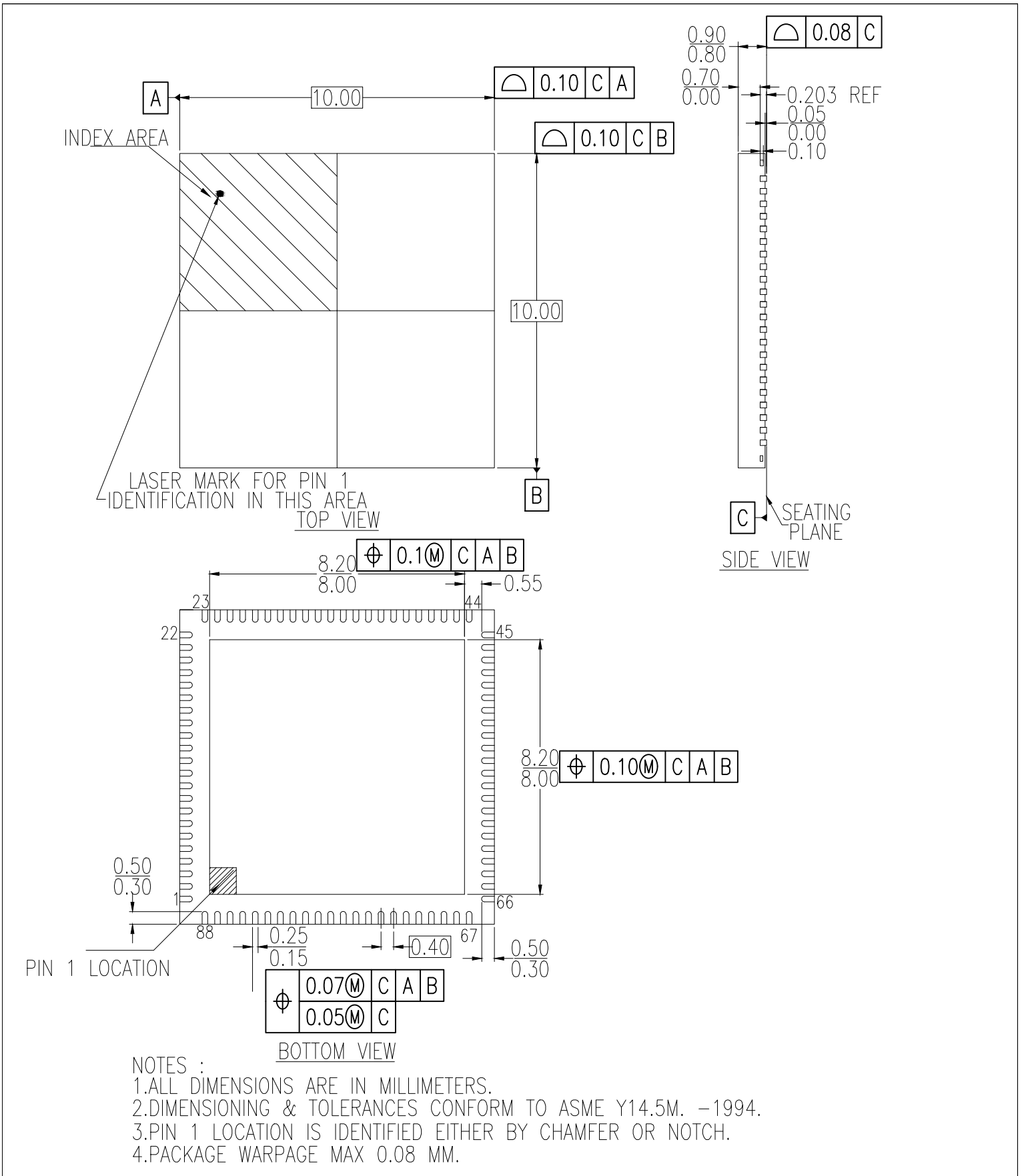

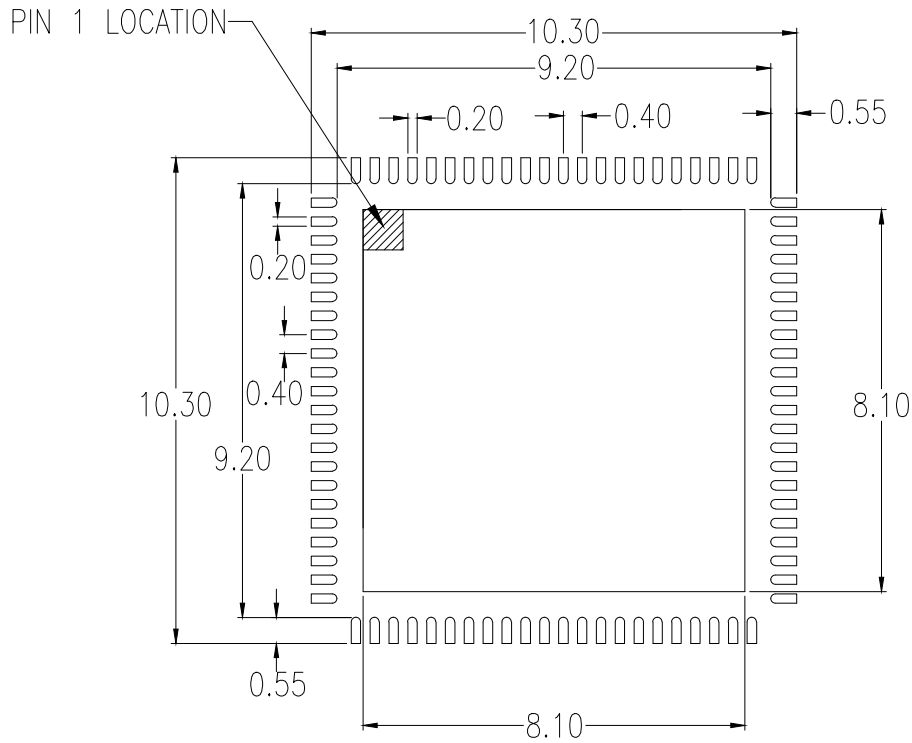

RECOMMENDED LAND PATTERN DIMENSION

NOTES:

1. ALL DIMENSIONS ARE IN MM. ANGLES IN DEGREES.
2. TOP DOWN VIEW. AS VIEWED ON PCB.
3. LAND PATTERN RECOMMENDATION PER IPC-7351B GENERIC REQUIREMENT FOR SURFACE MOUNT DESIGN AND LAND PATTERN.

Package Revision History		
Date Created	Rev No.	Description
March 8, 2018	Rev 02	Change QFN to VFQFPN, Change Pin 1 Identifier
Dec 4, 2017	Rev 01	New Format

IMPORTANT NOTICE AND DISCLAIMER

RENESAS ELECTRONICS CORPORATION AND ITS SUBSIDIARIES (“RENESAS”) PROVIDES TECHNICAL SPECIFICATIONS AND RELIABILITY DATA (INCLUDING DATASHEETS), DESIGN RESOURCES (INCLUDING REFERENCE DESIGNS), APPLICATION OR OTHER DESIGN ADVICE, WEB TOOLS, SAFETY INFORMATION, AND OTHER RESOURCES “AS IS” AND WITH ALL FAULTS, AND DISCLAIMS ALL WARRANTIES, EXPRESS OR IMPLIED, INCLUDING, WITHOUT LIMITATION, ANY IMPLIED WARRANTIES OF MERCHANTABILITY, FITNESS FOR A PARTICULAR PURPOSE, OR NON-INFRINGEMENT OF THIRD-PARTY INTELLECTUAL PROPERTY RIGHTS.

These resources are intended for developers who are designing with Renesas products. You are solely responsible for (1) selecting the appropriate products for your application, (2) designing, validating, and testing your application, and (3) ensuring your application meets applicable standards, and any other safety, security, or other requirements. These resources are subject to change without notice. Renesas grants you permission to use these resources only to develop an application that uses Renesas products. Other reproduction or use of these resources is strictly prohibited. No license is granted to any other Renesas intellectual property or to any third-party intellectual property. Renesas disclaims responsibility for, and you will fully indemnify Renesas and its representatives against, any claims, damages, costs, losses, or liabilities arising from your use of these resources. Renesas' products are provided only subject to Renesas' Terms and Conditions of Sale or other applicable terms agreed to in writing. No use of any Renesas resources expands or otherwise alters any applicable warranties or warranty disclaimers for these products.

(Disclaimer Rev.1.01 Jan 2024)

Corporate Headquarters

TOYOSU FORESIA, 3-2-24 Toyosu,
Koto-ku, Tokyo 135-0061, Japan
www.renesas.com

Trademarks

Renesas and the Renesas logo are trademarks of Renesas Electronics Corporation. All trademarks and registered trademarks are the property of their respective owners.

Contact Information

For further information on a product, technology, the most up-to-date version of a document, or your nearest sales office, please visit www.renesas.com/contact-us/.