

DATE CREATED		REVISIONS		
REV	DESCRIPTION	AUTHOR		
10/09/12	00	INITIAL RELEASE		KS
12/4/13	01	COMBINE POD & LAND PATTERN		J.H
2/19/14	02	ADD NOTE RECOMMENDED LAND PATTERN		J.H
9/11/17	03	UPDATE TO NEW FORMAT		J.H
12/14/20	04	ADD P2 AND DIMENSION TABLE		KC
11/16/21	05	ADD P3		CM

NOTE: REFER TO AGILE FOR OFFICIAL RELEASE

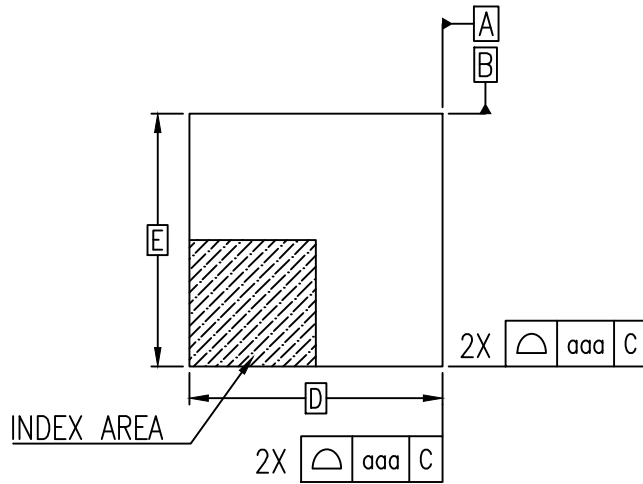

TOP VIEW

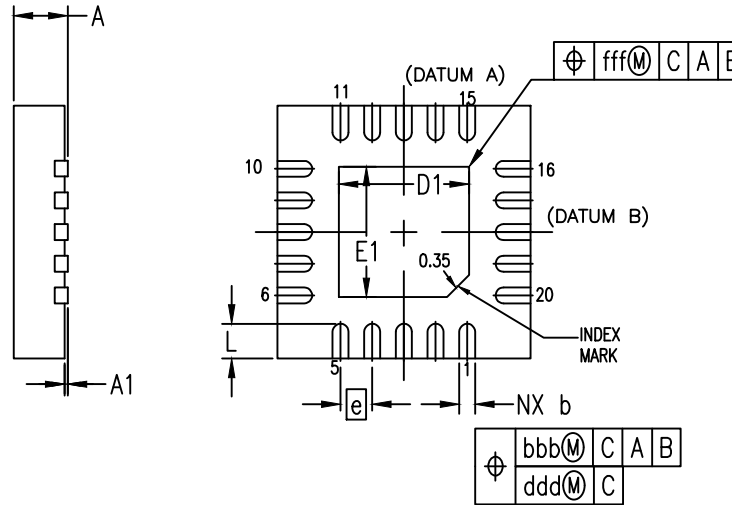

BOTTOM VIEW

COMMON DIMENSION

SYMBOL	DIMENSION		
	MIN	NOM	MAX
A	0.70	0.75	0.80
A1	0.00	0.02	0.05
A3	0.20 Ref.		
D	4.00 BSC		
E	4.00 BSC		
D1	SEE EPAD OPTION		
E1	SEE EPAD OPTION		
e	0.50 BSC		
L	SEE EPAD OPTION		
b	0.20	0.25	0.30
N	20		
aaa	SEE EPAD OPTION		
bbb	0.10		
ccc	0.10		
ddd	0.05		
eee	0.08		
fff	0.10		

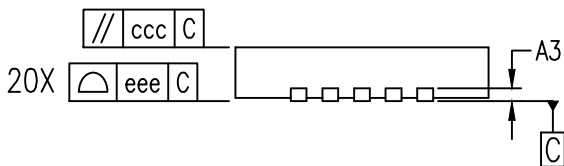

SIDE VIEW

EPAD OPTION

SYMBOL	P1			P2			P3		
	MIN	NOM	MAX	MIN	NOM	MAX	MIN	NOM	MAX
D1	1.96	2.06	2.16	2.00	2.10	2.20	2.60	2.70	2.80
E1	1.96	2.06	2.16	2.00	2.10	2.20	2.60	2.70	2.80
L	0.45	0.55	0.65	0.45	0.55	0.65	0.20	0.30	0.40
aaa	0.15			0.10			0.10		

- NOTE:
1. ALL DIMENSION ARE IN MM. ANGLES IN DEGREES
 2. COPLANARITY APPLIES TO THE EXPOSED PAD AS WELL AS THE TERMINALS
COPLANARITY SHALL NOT EXCEED 0.06 MM
 3. WARPAGE SHALL NOT EXCEED 0.10
 4. REFER JEDEC MO-220

TOLERANCES UNLESS SPECIFIED DECIMAL ANGULAR XX± ±1° XXX± XXXX±	6024 Silver Creek Valley Rd San Jose, CA 95138 PHONE: (408) 284-8200 FAX: (408) 284-3572		
	RENESAS TITLE 20-QFN, Package Outline Drawing 4.0 x 4.0 x 0.75 mm BODY 0.50mm PITCH NCG20		
SIZE C	DRAWING No. PSC-4445	REV 05	DO NOT SCALE DRAWING
			SHEET 1 OF 2

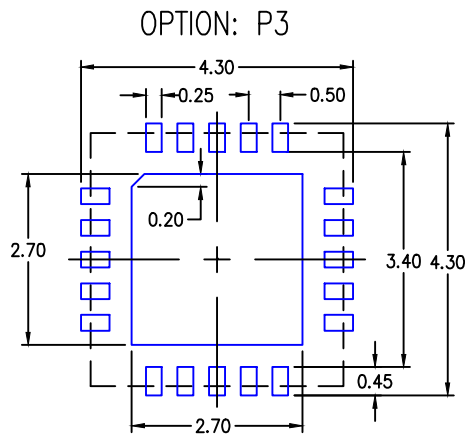
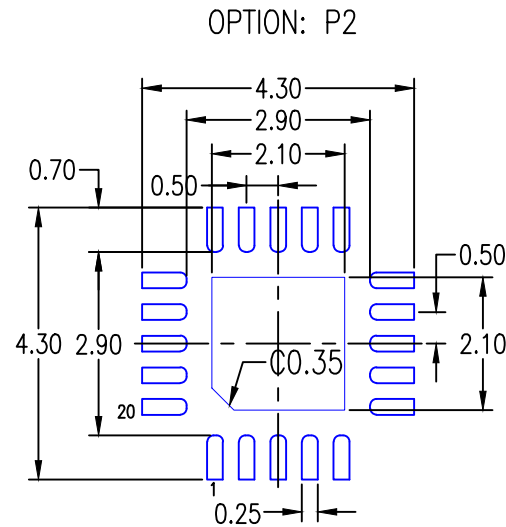
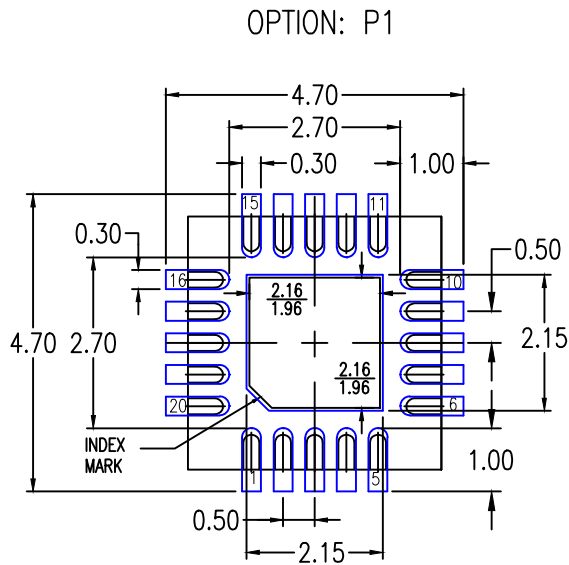

RECOMMENDED LAND PATTERN DIMENSION

- NOTE:
1. ALL DIMENSION ARE IN MM. ANGLES IN DEGREES
 2. TOP DOWN VIEW AS VIEWED ON PCB
 3. LAND PATTERN RECOMMENDATION PER IPC-7351B GENERIC REQUIREMENT FOR SURFACE MOUNT DESIGN AND LAND PATTERN

		REVISIONS	
DATE CREATED	REV	DESCRIPTION	AUTHOR
10/09/12	00	INITIAL RELEASE	KS
12/4/13	01	COMBINE POD & LAND PATTERN	J.H
2/19/14	02	ADD NOTE RECOMMENDED LAND PATTERN	J.H
9/11/17	03	UPDATE TO NEW FORMAT	J.H
12/14/20	04	ADD P2 AND DIMENSION TABLE	KC
11/16/21	05	ADD P3	CM
NOTE: REFER TO AGILE FOR OFFICIAL RELEASE			

TOLERANCES UNLESS SPECIFIED		6024 Silver Creek Valley Rd San Jose, CA 95138 PHONE: (408) 284-8200 FAX: (408) 284-3572	
DECIMAL	ANGULAR		
XX±	±1°		
XXX±		TITLE 20-QFN, Package Outline Drawing 4.0 x 4.0 x 0.75 mm BODY 0.50mm PITCH NCG20	
XXXX±		SIZE C	REV 05
		DRAWING No. PSC-4445	
DO NOT SCALE DRAWING			SHEET 2 OF 2