

NOTES:

1. ALL DIMENSIONS AND TOLERANCES ARE PER ASME Y14.5M-1994.
  2. ALL DIMENSIONS ARE IN MILLIMETERS.
- △ SEATING PLANE AND PRIMARY DATUM -C- ARE DEFINED BY THE CONTACT POINTS OF THREE OR MORE SOLDER BALLS THAT SUPPORT THE DEVICE WHEN PLACED ON A TOP OF A PLANAR SURFACE.
- ▽ BOTTOM PIN#1 INDICATOR OPTIONAL.

| REVISIONS |                                |          |          |
|-----------|--------------------------------|----------|----------|
| REV       | DESCRIPTION                    | DATE     | APPROVED |
| 00        | INITIAL RELEASE                | 05/29/14 | JH       |
| 01        | CORRECT PAGE 2 TITLE BLOCK     | 8/25/14  | JH       |
| 02        | CHANGE BUMP and BODY TOLERANCE | 6/5/15   | JH       |

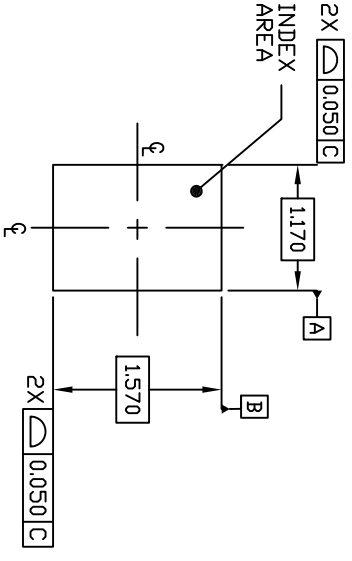

TOP VIEW

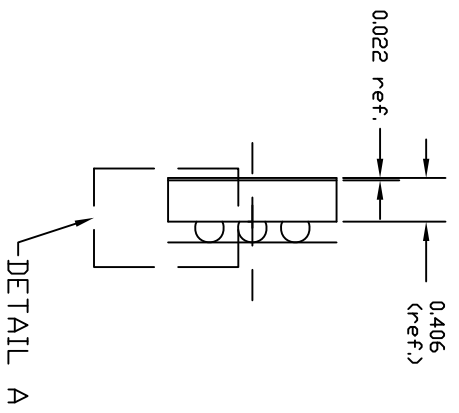

SIDE VIEW

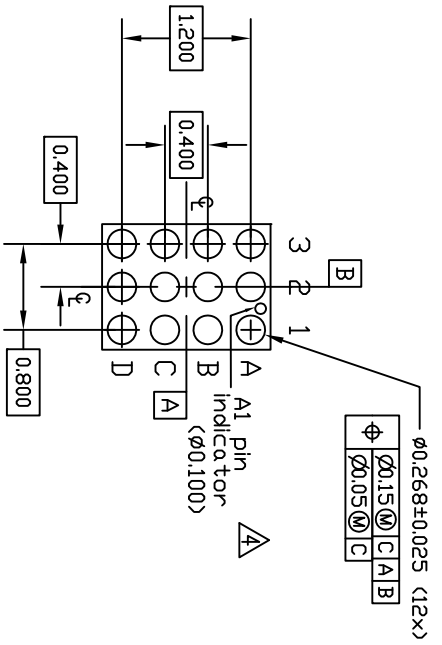

BOTTOM VIEW

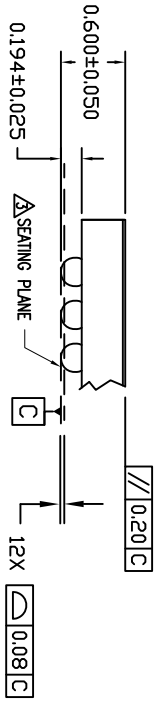

DETAIL A

<ROTATED 90 DEG CW>

|                             |             |   |              |
|-----------------------------|-------------|---|--------------|
| TOLERANCES UNLESS SPECIFIED |             | 6024 SILVER CREEK VALLEY ROAD, SAN JOSE, CA 95138 |              |
| DECIMAL                     | ANGULAR     | PHONE: (408) 284-4200                             |              |
| XXX ± 0.05                  | ±           | FAX: (408) 284-3572                               |              |
| XXXX ± 0.012                |             |   |              |
| XXXXX                       |             |   |              |
| APPROVALS                   | DATE        | TITLE   |              |
| DRAWN BY                    | 05/29/14    | ANG12 PACKAGE OUTLINE                             |              |
| CHECKED                     |             | 1.170 x 1.570mm BODY                              |              |
|                             |             | 0.4mm PITCH DS98A                                 |              |
| SIZE                        | DRAWING No. | DO NOT SCALE DRAWING                              | REV          |
| C                           | PSC-4483    |   | 02           |
|                             |             |   | SHEET 1 OF 2 |

| REVISIONS |                                |          |          |
|-----------|--------------------------------|----------|----------|
| REV       | DESCRIPTION                    | DATE     | APPROVED |
| 00        | INITIAL RELEASE                | 05/29/14 | JH       |
| 01        | CORRECT PAGE 2 TITLE BLOCK     | 8/25/14  | JH       |
| 02        | CHANGE BUMP and BODY TOLERANCE | 6/5/15   | JH       |

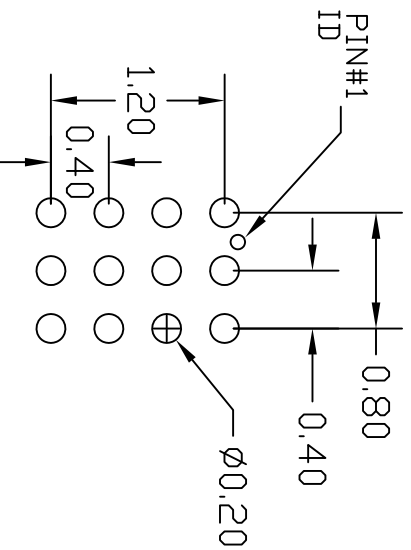

RECOMMENDED LAND PATTERN DIMENSION

NOTE:

- 1) ALL dimensions are in mm, Angles in degrees.
- 2) Top down view, as view on PCB.
- 3) NSMD Land Pattern Assumed
- 4) Land Pattern Recommendation as per IPC-7351B generic requirement for surface mount design and Land Pattern.

|                                |          |   |                      |
|--------------------------------|----------|---|----------------------|
| TOLERANCES<br>UNLESS SPECIFIED |          | 6024 SILVER CREEK<br>VALLEY ROAD, SAN JOSE,<br>CA 95138<br>PHONE: (408) 294-8200<br>FAX: (408) 294-3572                             |                      |
| DECIMAL                        | ANGULAR  | <br><a href="http://www.idt.com">www.idt.com</a> |                      |
| XX.X 0.05                      | ±        |   |                      |
| APPROVALS                      | DATE     | TITLE   | SIZE                 |
| DRAWN 09*                      | 05/29/14 | AMG12 PACKAGE OUTLINE   | C                    |
| CHECKED                        |          | 1.170 x 1.570mm BODY<br>0.4mm PITCH DSBGA   | DRAWING No. PSC-4483 |
| XXXXE                          |          |   | REV 02               |
| DO NOT SCALE DRAWING           |          |   | SHEET 2 OF 2         |