

REV	DESCRIPTION	DATE	APPROVED
00	INITIAL RELEASE	2/22/16	JHUA

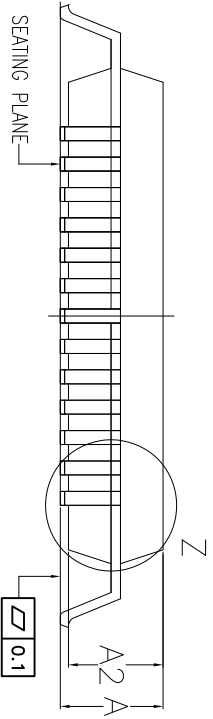
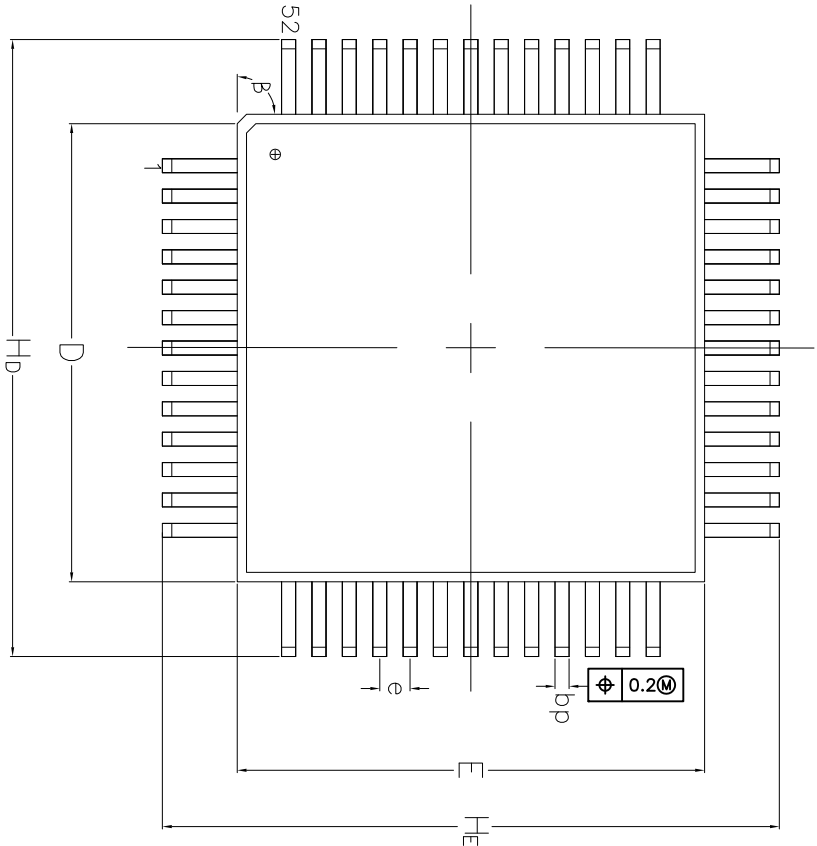

- 2. WEIGHT <math>< 0.6\text{ g}</math>
- 3. PACKAGE BODY MATERIAL LOW STRESS EPOXY
- 4. LEAD MATERIAL Cu-ALLOY
- 5. LEAD FINISH SOLDER PLATING
- 6. LEAD FORM Z-BENDS

DIMENSION OF SUB-GROUP B1	
e_{nom}	0.65
A_{max}	2.35
b_{min}	0.22
b_{pmx}	0.38
H_{min}	12.95
H_{max}	13.45
H_{pmn}	12.95
L_{pmn}	0.73

DIMENSION OF SUB-GROUP C1	
A_{min}	2.05
$A1\ min$	0.10
$A1\ max$	0.25
$A2\ min$	1.95
$A2\ max$	2.10
$C\ min$	0.13
$C\ max$	0.23
D_{min}	9.90
D_{max}	10.10
E_{min}	9.90
E_{max}	10.10
θ_{min}	0°
θ_{max}	10°
B	45°

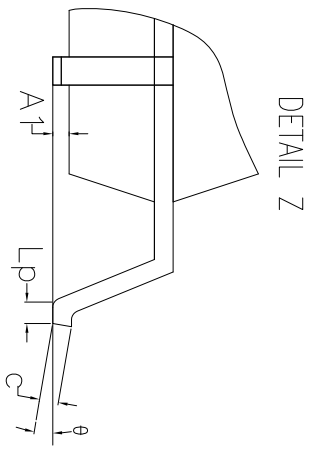

TOLERANCES UNLESS SPECIFIED	DECIMAL	ANGULAR
XXXX	±	
XXXX		
APPROVALS	DATE	TITLE
DRAWN \varnothing 24G	2/22/16	DRG52 PACKAGE OUTLINE
CHECKED		10.0 x 10.0 mm BODY
		0.65 mm PITCH PQFP
SIZE	DRAWING No.	REV
C	PSC-4644	00
DO NOT SCALE DRAWING		
SHEET 1 OF 1		

6024 Silver Creek Valley Rd
San Jose, CA 95138
PHONE: (408) 727-6116
FAX: (408) 492-8674

www.IDT.com