

Plastic Packages for Integrated Circuits

Package Outline Drawing

Y40.17x19

40 I/O 17.0mm x 19.0mm x 3.55mm HDA MODULE

Rev 3, 4/17

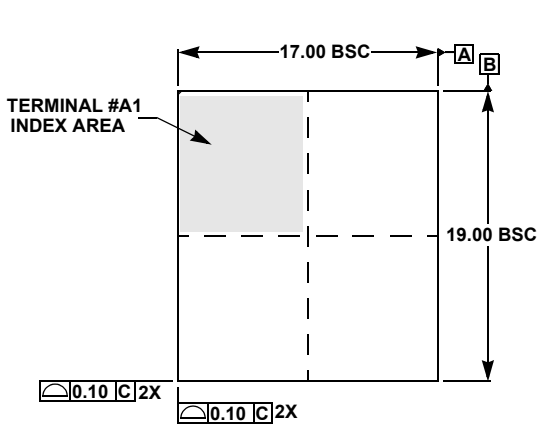

TOP VIEW

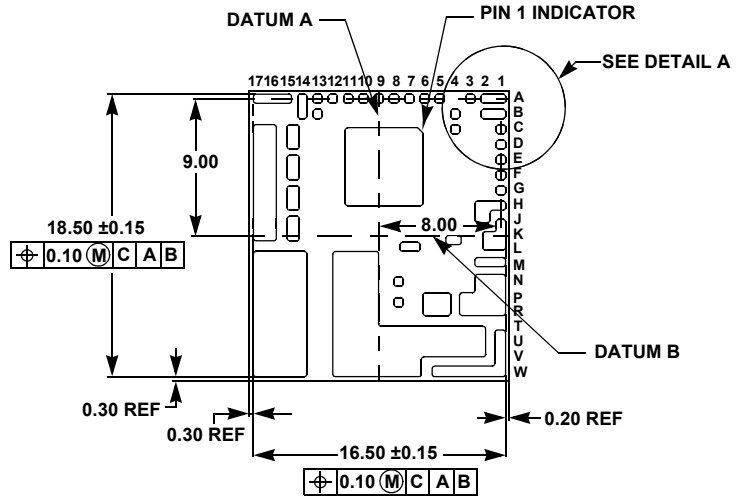

BOTTOM VIEW

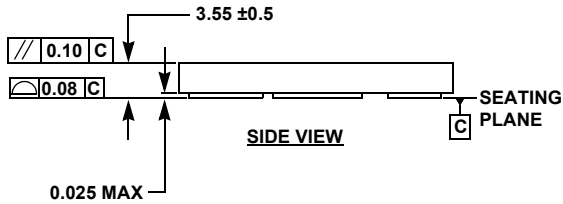

SIDE VIEW

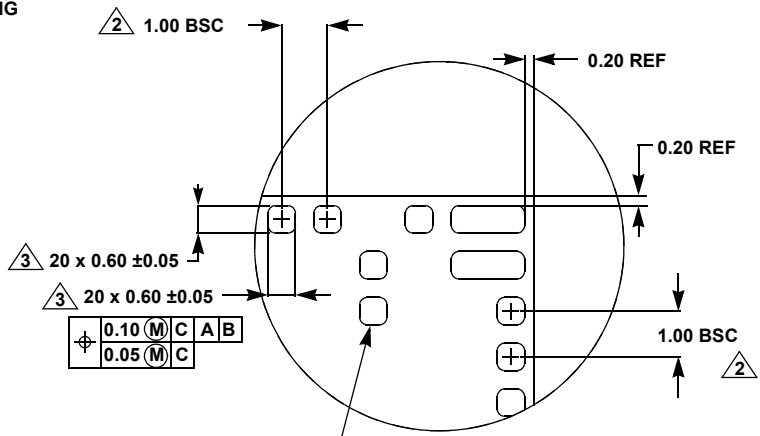

DETAIL A

NOTES:

1. ALL DIMENSIONS ARE IN MILLIMETERS.
2. REPRESENTS THE BASIC LAND GRID PITCH.
3. THE TOTAL NUMBER OF I/O (EXCLUDING DUMMY PADS)
4. UNLESS OTHERWISE SPECIFIED, TOLERANCE: DECIMAL ±0.10
5. DIMENSIONING AND TOLERANCING PER ASME Y14.M-2009
6. THE CONFIGURATION OF THE PIN#1 IDENTIFIER IS OPTIONAL, BUT MUST BE LOCATED WITHIN THE ZONE INDICATED. THE PIN #1 IDENTIFIER MAY BE EITHER A MOLD OR MARK FEATURE.

Plastic Packages for Integrated Circuits

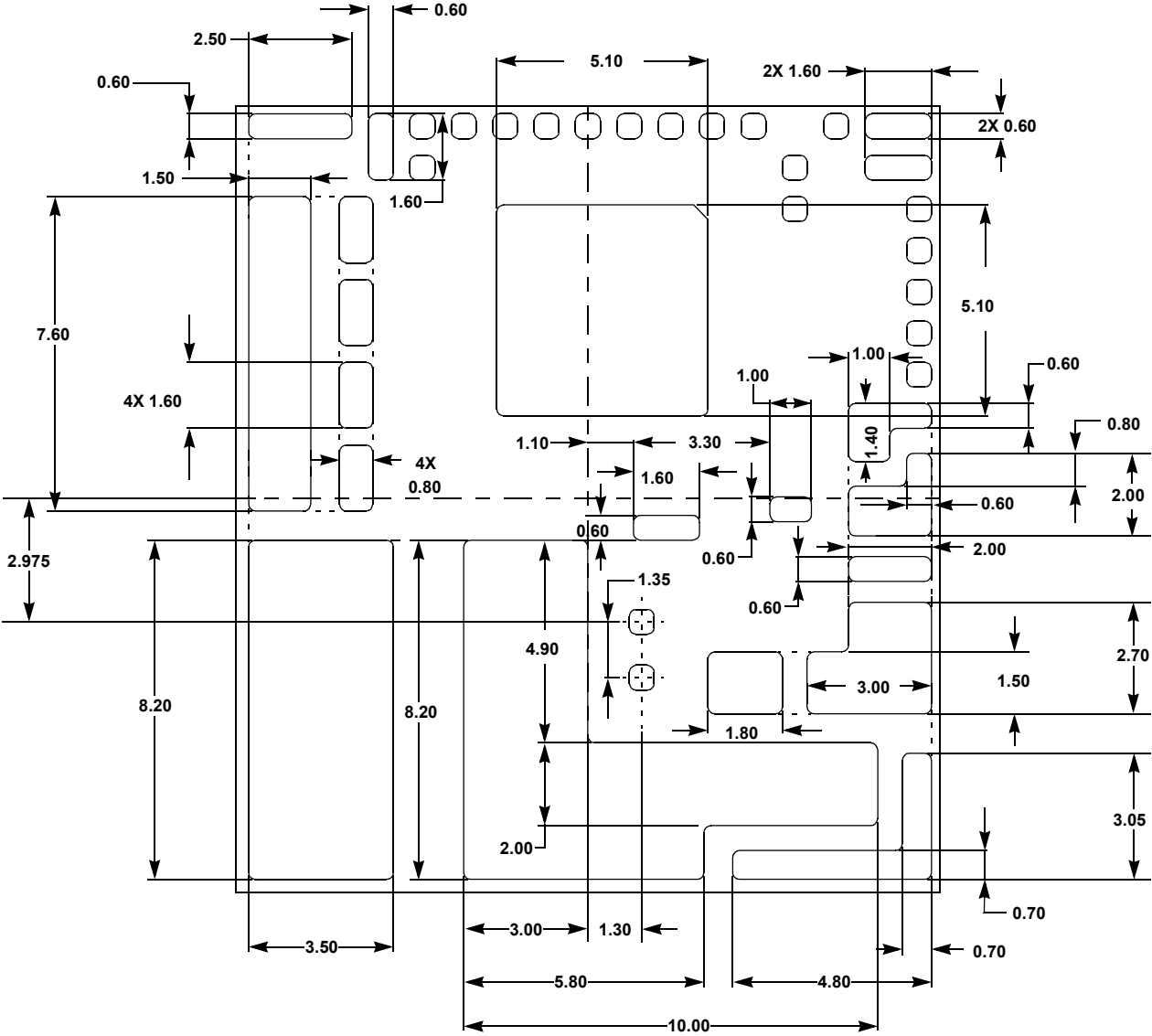

SIZE DETAILS FOR THE 16 EXPOSED DAPS

BOTTOM VIEW

Plastic Packages for Integrated Circuits

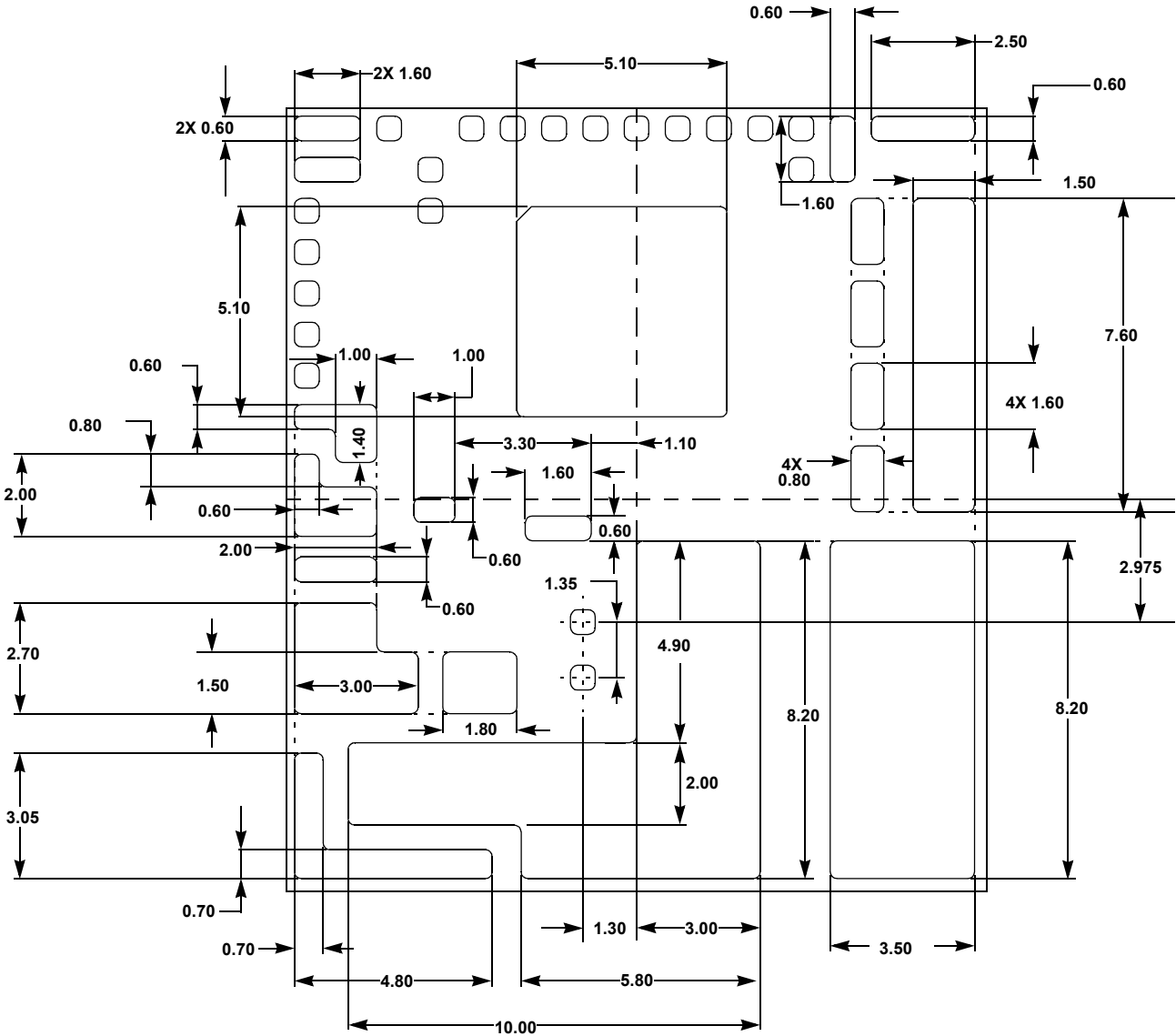

SIZE DETAILS FOR THE 16 EXPOSED DAPS

TOP VIEW

Plastic Packages for Integrated Circuits

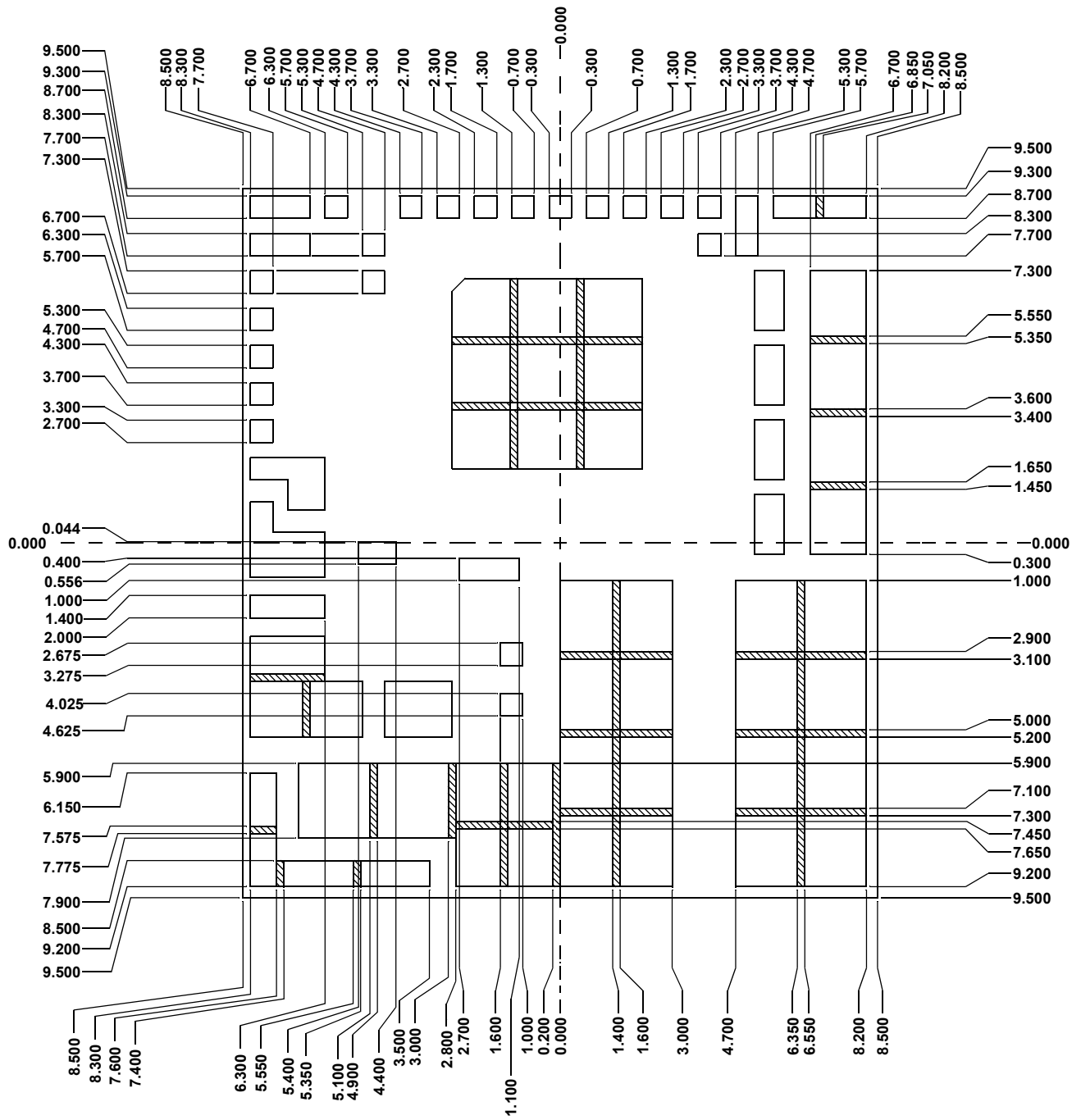

RECOMMENDED SOLDER MASK DEFINED PCB LAND PATTERN (SHEET 1 OF 2)

TOP VIEW

Plastic Packages for Integrated Circuits

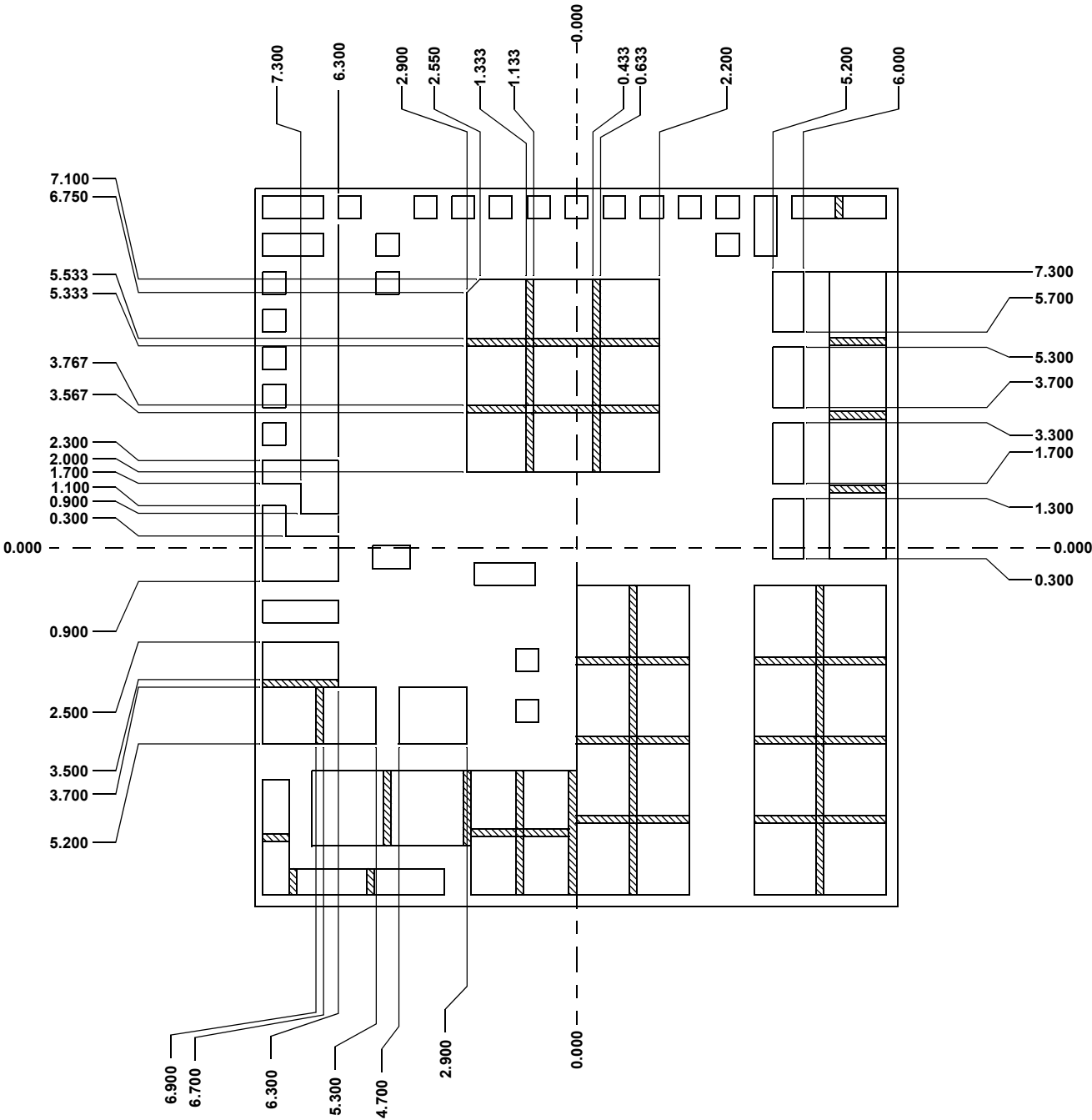

RECOMMENDED SOLDER MASK DEFINED PCB LAND PATTERN (SHEET 2 OF 2)

TOP VIEW

Plastic Packages for Integrated Circuits

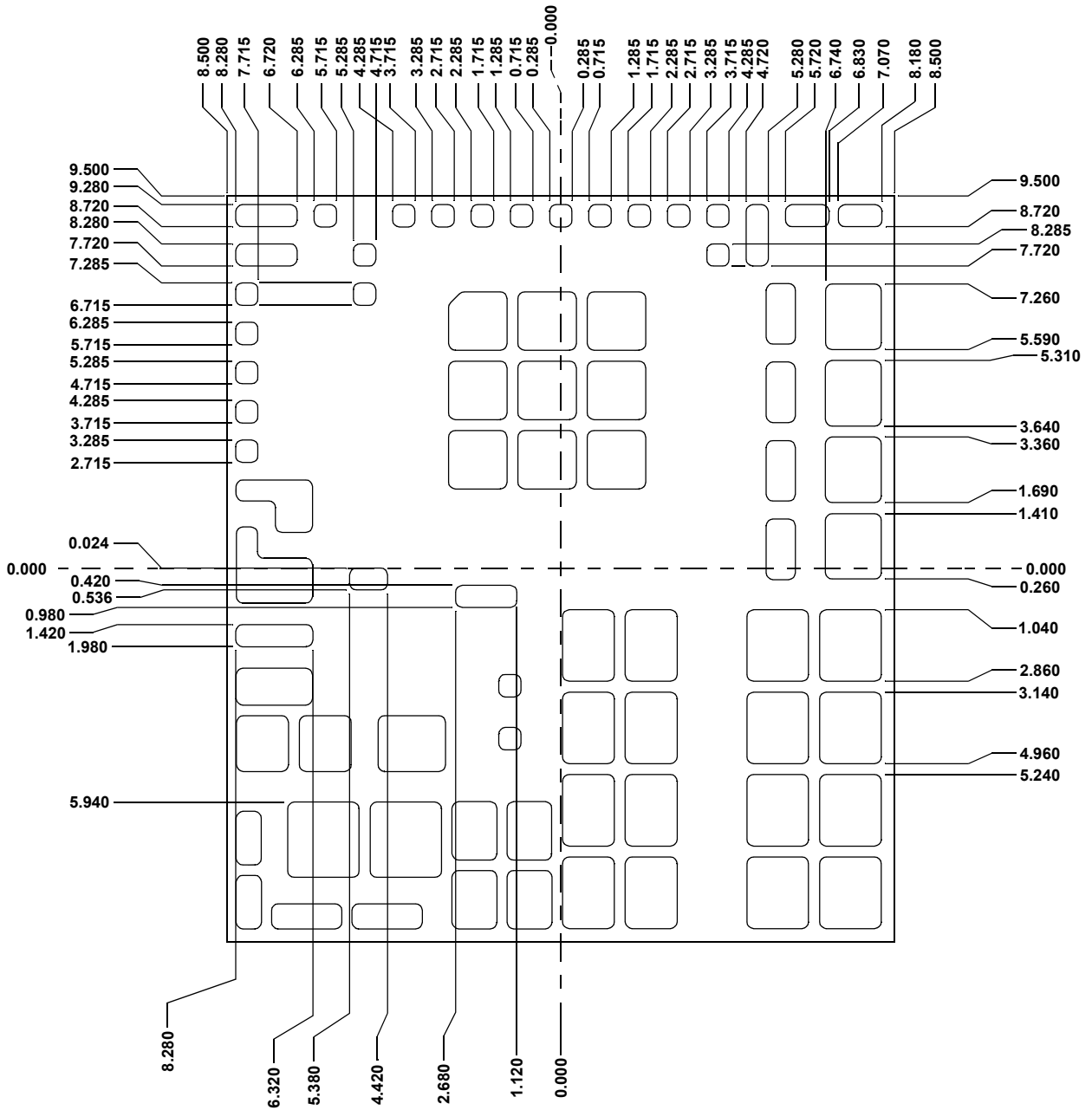

RECOMMENDED STENCIL PATTERN (90% PASTE TO PAD) (SHEET 1 OF 2)

TOP VIEW

Plastic Packages for Integrated Circuits

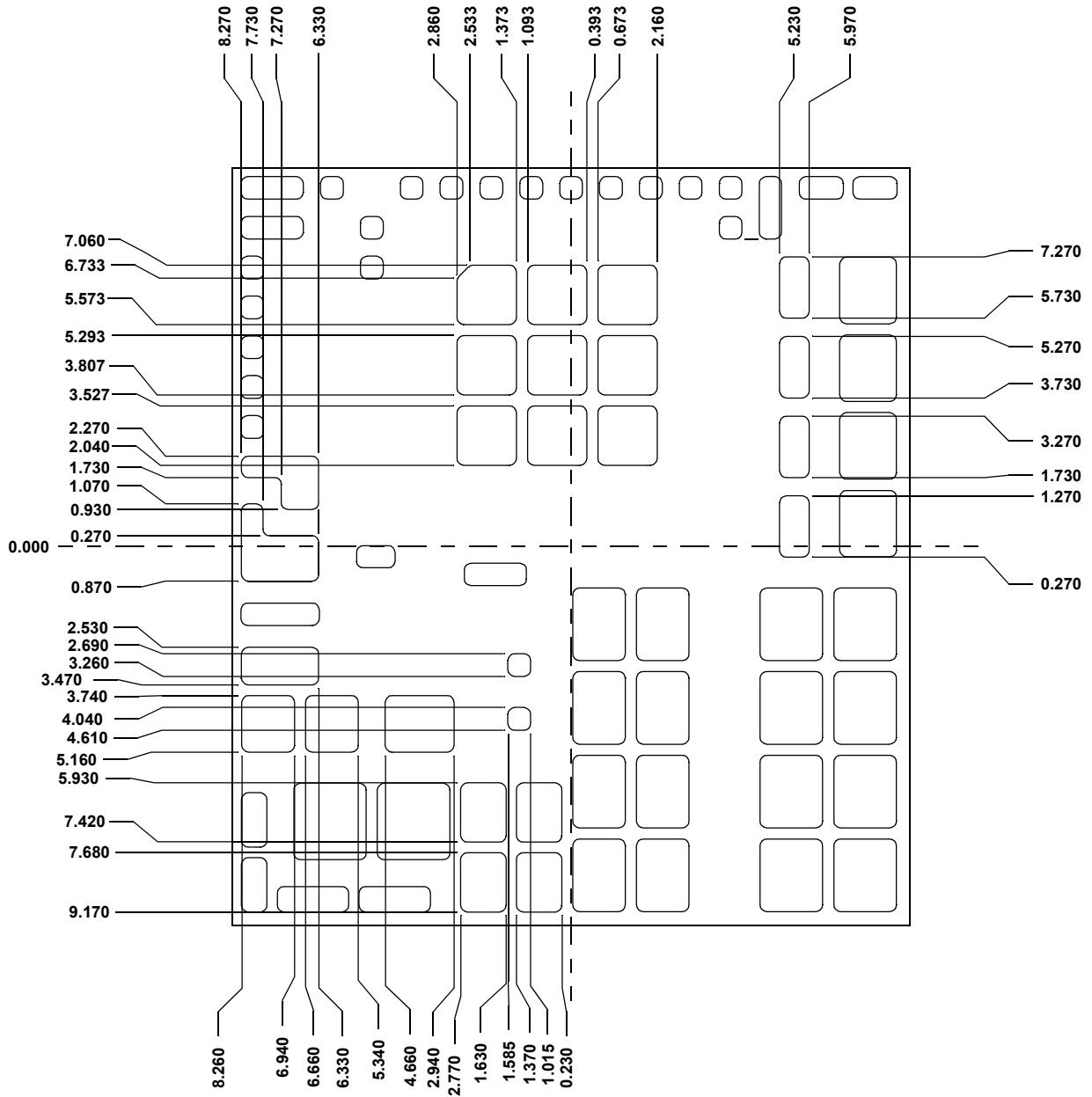

RECOMMENDED STENCIL PATTERN (90% PASTE TO PAD) (SHEET 2 OF 2)

TOP VIEW