

Brief Description

The ZSPM4521 is a DC/DC synchronous switching lithium-ion (Li-Ion) battery charger with fully integrated power switches, internal compensation, and full fault protection. It uses a temperature-independent photovoltaic maximum power point tracking (MPPT) function to optimize power output from the source during Full-Charge Constant-Current (CC) Mode. Its switching frequency of 1MHz enables the use of small filter components, resulting in smaller board space and reduced bill-of material costs.

During Full-Charge Constant-Current Mode, the duty cycle is controlled by the MPPT regulator. Once the battery’s termination voltage is reached, the regulator operates in Constant Voltage Mode. In this mode, the ZSPM4521 modulates the charging current until the battery reaches full charge. When the regulator is disabled (the EN pin is low), the device draws 10µA (typical) quiescent current (Disabled Mode).

The ZSPM4521 includes supervisory reporting through the NFLT (inverted fault) open-drain output to interface other components in the system. Device programming is achieved by an I²C™* interface through the SCL and SDA pins.

Benefits

- Up to 1.5A of continuous output current in Full-Charge Constant Current (CC) Mode
- High efficiency – up to 92% with typical loads

Available Support

- Evaluation Kit
- Documentation

Features

- Temperature-independent photovoltaic maximum power tracking (MPPT) regulator
- VBAT reverse-current blocking
- Programmable temperature-compensated termination voltage: 3.94V to 4.18V ± 1%
- User programmable maximum charge current: 50mA to 1500mA
- Supervisor for V_{BAT} reported at the NFLT pin
- Input supply under-voltage lockout
- Full protection for VBAT over-current, over-temperature, VBAT over-voltage, and charging timeout
- Charge status indication
- I²C™ program interface with EEPROM registers

Related IDT Smart Power Products

- ZSPM4523 DC/DC Synchronous Switching Super Capacitor Charger With MPPT Regulator
- ZSPM4551 High-Efficiency Li-Ion Battery Charger
- ZSPM4121 Ultra-low Power Under-Voltage Switch
- ZSPM4141 Ultra-Low-Power Linear Regulator

Physical Characteristics

- Wide input voltage range: 4.0V to 7.2V
- Junction operating temperature: -40°C to 125°C
- Package: 16-pin PQFN (4mm x 4mm)

ZSPM4521 Application Circuit

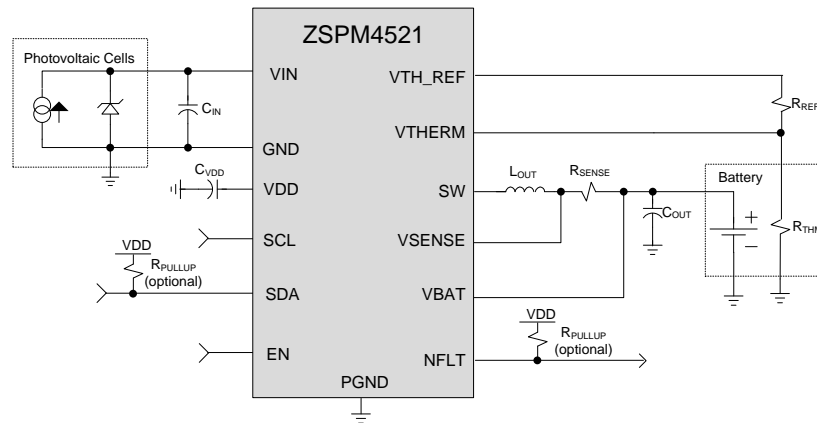

* I²C™ is a trademark of NXP.

ZSPM4521 Block Diagram

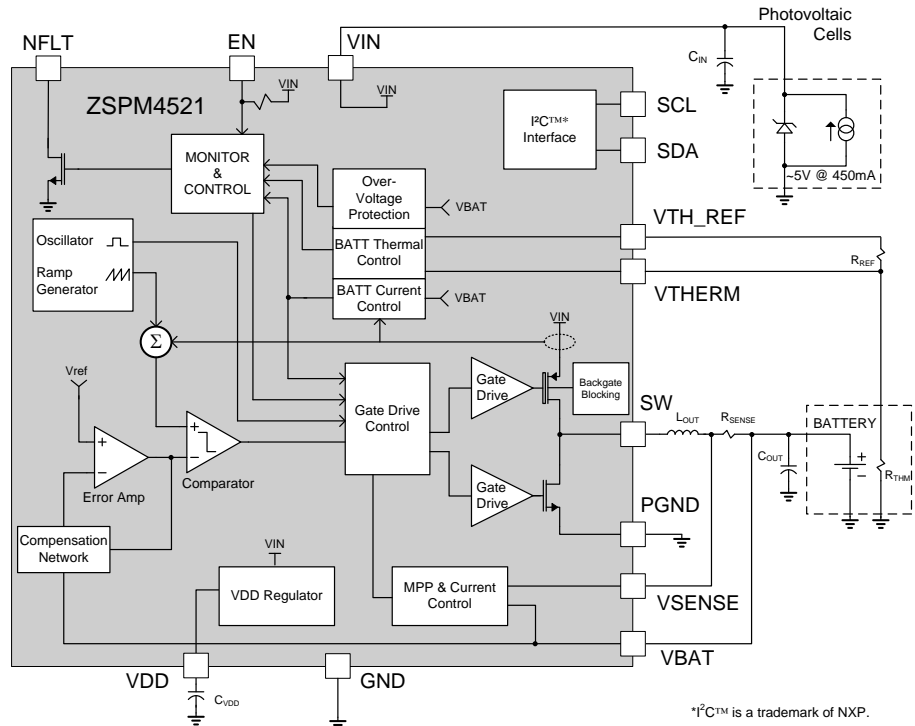

- Typical Applications**
- Portable solar chargers
 - Off-grid systems
 - Wireless sensor networks
 - HVAC controls

Ordering Information

Ordering Code	Description	Package
ZSPM4521AA1W	ZSPM4521 High Efficiency Li-Ion Battery Charger for Photovoltaic Sources	16-pin PQFN / 7" Reel (1000 parts)
ZSPM4521AA1R	ZSPM4521 High Efficiency Li-Ion Battery Charger for Photovoltaic Sources	16-pin PQFN / 13" Reel (3300 parts)
ZSPM4521KIT	ZSPM4521 Evaluation Kit	Kit

*I²C™ is a trademark of NXP.

IMPORTANT NOTICE AND DISCLAIMER

RENESAS ELECTRONICS CORPORATION AND ITS SUBSIDIARIES (“RENESAS”) PROVIDES TECHNICAL SPECIFICATIONS AND RELIABILITY DATA (INCLUDING DATASHEETS), DESIGN RESOURCES (INCLUDING REFERENCE DESIGNS), APPLICATION OR OTHER DESIGN ADVICE, WEB TOOLS, SAFETY INFORMATION, AND OTHER RESOURCES “AS IS” AND WITH ALL FAULTS, AND DISCLAIMS ALL WARRANTIES, EXPRESS OR IMPLIED, INCLUDING, WITHOUT LIMITATION, ANY IMPLIED WARRANTIES OF MERCHANTABILITY, FITNESS FOR A PARTICULAR PURPOSE, OR NON-INFRINGEMENT OF THIRD-PARTY INTELLECTUAL PROPERTY RIGHTS.

These resources are intended for developers who are designing with Renesas products. You are solely responsible for (1) selecting the appropriate products for your application, (2) designing, validating, and testing your application, and (3) ensuring your application meets applicable standards, and any other safety, security, or other requirements. These resources are subject to change without notice. Renesas grants you permission to use these resources only to develop an application that uses Renesas products. Other reproduction or use of these resources is strictly prohibited. No license is granted to any other Renesas intellectual property or to any third-party intellectual property. Renesas disclaims responsibility for, and you will fully indemnify Renesas and its representatives against, any claims, damages, costs, losses, or liabilities arising from your use of these resources. Renesas' products are provided only subject to Renesas' Terms and Conditions of Sale or other applicable terms agreed to in writing. No use of any Renesas resources expands or otherwise alters any applicable warranties or warranty disclaimers for these products.

(Disclaimer Rev.1.01 Jan 2024)

Corporate Headquarters

TOYOSU FORESIA, 3-2-24 Toyosu,
Koto-ku, Tokyo 135-0061, Japan
www.renesas.com

Trademarks

Renesas and the Renesas logo are trademarks of Renesas Electronics Corporation. All trademarks and registered trademarks are the property of their respective owners.

Contact Information

For further information on a product, technology, the most up-to-date version of a document, or your nearest sales office, please visit www.renesas.com/contact-us/.