

---

## Op-amp Crash Course Part 1: Basics

---

Understanding the basic principles of operational amplifiers (op-amps) is vital to selling microcontrollers (MCU) in industrial, automotive, and telecom applications.

Op-amps amplify and filter the output signals of real-world sensors to make them accessible for analog-to-digital converters, whether they are discrete or integrated into an MCU.

Part 1 of this tutorial provides the basics of op-amp understanding, covering the items listed below.

### Contents

<b>1. What is an Operational Amplifier?</b> .....	<b>2</b>
<b>2. Negative Feedback</b> .....	<b>3</b>
<b>3. Key Op-amp Configurations</b> .....	<b>3</b>
<b>4. Most Common Applications for Renesas Op-amps</b> .....	<b>5</b>
4.1 Sensor Signal Conditioning of Industrial Sensors .....	5
4.2 Signal Amplification of Low-Voltage Vibration Sensors .....	5
4.3 Low-Side Current Sensing in a Motor Drive for AC-Induction Motors .....	6
4.4 High-Voltage High-Side Current Sensing in Motor Drives for DC Motors .....	6
<b>5. Conclusion</b> .....	<b>7</b>
<b>6. Revision History</b> .....	<b>7</b>

# 1. What is an Operational Amplifier?

An op-amp (operational amplifier) is a differential voltage amplifier with a very high gain that can range from  $10^4$  (ten thousand) up to  $10^8$  (one hundred million).

The op-amp is the most used building block for various analog circuits. Its symbol is a triangle that points towards signal flow and includes a plus and a minus sign, representing the inverting and non-inverting signal inputs. The symbol comes with and without a capital A in its center, signifying the amplification of the device, also known as op-amp gain.

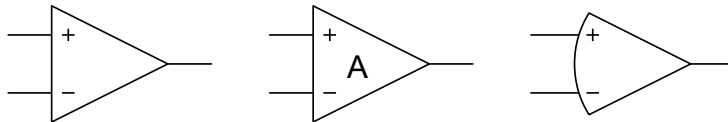

Figure 1. Op-amp Symbols (Supply terminals omitted for clarity)

An op-amp has a minimum of five terminals:

- A positive supply voltage terminal,  $V_{s+}$
- A negative supply voltage terminal,  $V_{s-}$
- A non-inverting signal input,  $IN+$
- An inverting signal input,  $IN-$
- A signal output,  $OUT$

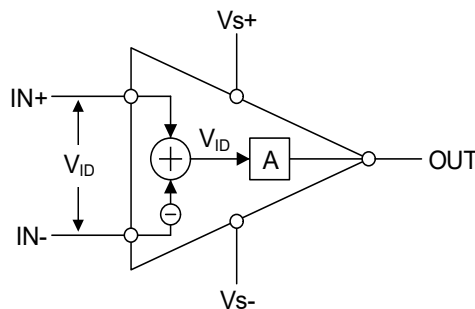

Figure 2. Op-amp Terminals and internal Operation

The purpose of an op-amp is to amplify a small voltage difference,  $V_{ID}$ , between the inverting and non-inverting inputs by the large op-amp gain of  $A = 10^4$  to  $10^8$ :

$$V_{OUT} = A \times V_{ID}$$

To create this voltage difference, the voltage at the inverting input,  $V_{IN-}$ , is internally inverted to  $-V_{IN-}$  and then added to the voltage at the non-inverting input,  $V_{IN+}$ , yielding the difference voltage:

$$V_{ID} = V_{IN+} + (-V_{IN-}) = V_{IN+} - V_{IN-}$$

## 2. Negative Feedback

An operational amplifier never works alone. To constitute a useful amplifier circuit, an op-amp requires negative feedback. Negative feedback means the output voltage is fed back to the inverting input, either in full through a direct connection (Figure 3) or fractional using a voltage divider (Figure 4).

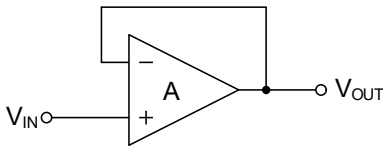

Figure 3. Op-amp with full Feedback

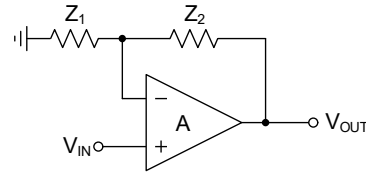

Figure 4. Op-amp with fractional Feedback

In the case of fractional feedback, the  $Z_1$  and  $Z_2$  impedance of the voltage divider can be purely resistive (resistors only) or complex (a combination of capacitors and resistors).

Therefore, changing the type of feedback changes the circuit configuration the op-amp is working in.

## 3. Key Op-amp Configurations

Figure 5 to Figure 11 depict the key op-amp configurations found in industrial applications, such as sensor signal conditioning and current sensing.

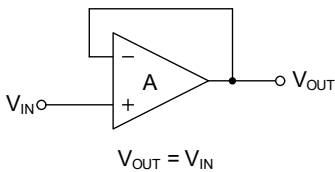

$$V_{OUT} = V_{IN}$$

Figure 5. Input Voltage-Buffer

Connecting the output directly to its inverting input configures the op-amp into a unity gain (gain of one) amplifier, also called an input voltage buffer.

This circuit converts a high-impedance voltage source into a low-impedance voltage source and is often used as a voltage reference buffer.

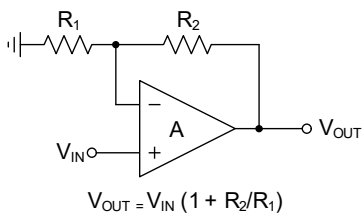

$$V_{OUT} = V_{IN} (1 + R_2/R_1)$$

Figure 6. Non-inverting Amplifier

Connecting the output using a voltage divider to its inverting input and applying the input voltage to the non-inverting input configures the op-amp into a non-inverting amplifier with a gain of  $1 + R_2/R_1$ .

This circuit is used to amplify input signals without shifting the signal phase between output and input voltage.

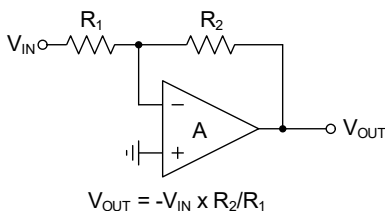

$$V_{OUT} = -V_{IN} \times R_2/R_1$$

Figure 7. Inverting Amplifier

Applying the input voltage to the inverting signal path adds a  $180^\circ$  phase shift between input and output and configures the op-amp into an inverting amplifier with a gain of  $-R_2/R_1$ .

This circuit is used to amplify input signals that require phase inversion.

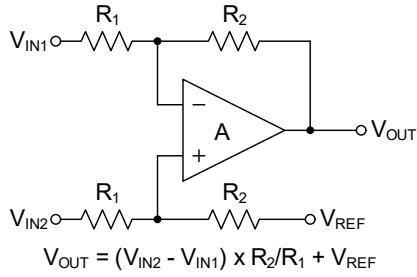

Figure 8. Difference Amplifier with Resistors

Applying two voltage dividers with the same resistor ratio to both op-amp inputs results in the difference amplifier configuration with a circuit gain of  $R_2/R_1$ .

This circuit is used to amplify the differential output voltage of low-impedance bridge sensors and the voltage drop across current sensing resistors.

The reference voltage,  $V_{REF}$ , sets the DC mid-level of the dynamic output voltage range.

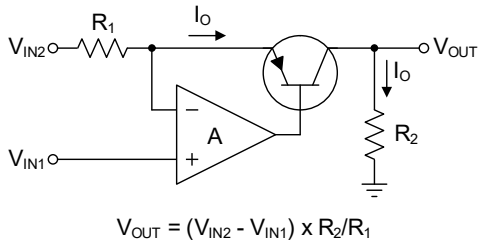

Figure 9. Diff – Amp with Transistor and Resistors

Replacing the resistor in the feedback loop with a transistor results in a different type of differential amplifier.

This circuit is mostly used in current sensing applications, where the voltage drops across a current sense resistor, measured between  $V_{IN2}$  and  $V_{IN1}$ , and then amplified by the resistor ratio.

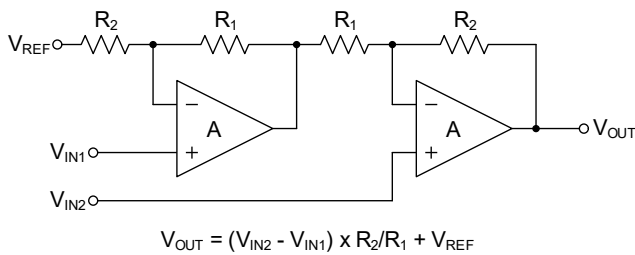

Figure 10. Instrumentation Amplifier with two Op-amps

Operating two non-inverting amplifiers, as shown in [Figure 10](#), results in a low-cost instrumentation amplifier.

This circuit is commonly used to amplify the differential output voltage of high-impedance bridge sensors, such as 10kΩ strain gauges.

The reference voltage,  $V_{REF}$ , sets the DC mid-level of the output voltage in single-supply applications.

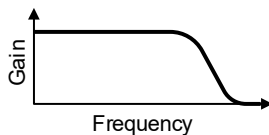
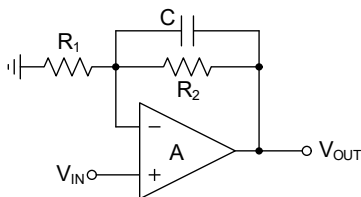

Figure 11. Low-Pass Filter

Adding a capacitor parallel to  $R_2$  converts the initial non-inverting amplifier into an active low-pass filter.

Low-pass filters are used to clean up the output signal from high-frequency noise before it enters the inputs of an ADC.

## 4. Most Common Applications for Renesas Op-amps

### 4.1 Sensor Signal Conditioning of Industrial Sensors

Figure 12 shows a typical signal conditioning circuit for a bridge sensor. The circuit uses three op-amps (A1 to A3) in front of SAR ADCs (successive approximation analog-to-digital converters).

Bridge sensors can measure mass, pressure, torsion, or strain. They are designed as a Wheatstone bridge, with variable resistor elements in one, two, or all four legs. Without the application of force, the resistance in each leg is the same, and the bridge is balanced, making the bridge voltage  $V_{BR} = 0V$ . When applying force, the resistance in the legs changes, which makes the bridge unbalanced and  $V_{BR} \neq 0V$ .

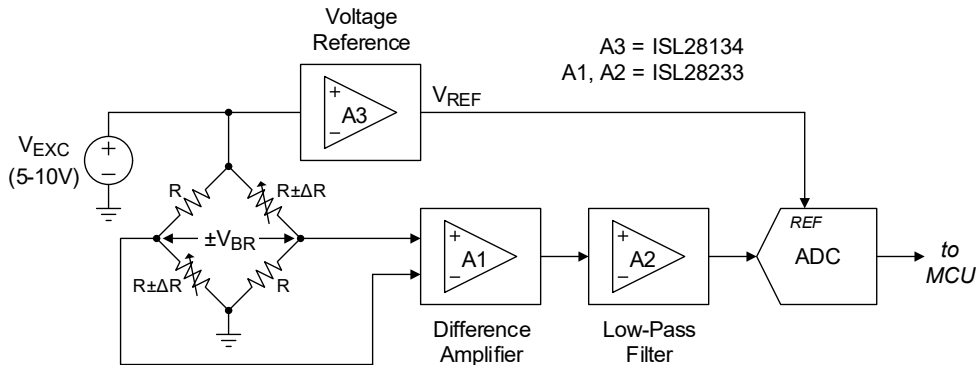

Figure 12. Low-Impedance Bridge Sensor Conditioning with ISL28233

A1 is configured as a difference amplifier that removes the high DC voltage at both sensor outputs and only amplifies their voltage difference from as low as  $500\mu V$  up to the ADC's input range (often 0 to 2.5V).

A2 is configured as a low-pass filter, removing high-frequency noise from the amplified difference signal before applying it to the ADC input.

A3 is configured as a voltage reference that sets the full-scale range of the ADC input.

### 4.2 Signal Amplification of Low-Voltage Vibration Sensors

Figure 13 shows a low-voltage amplifier boosting the output signals of a vibration sensor, also called an accelerometer, often found in game controllers. As the sensor output impedance can be as high as  $50k\Omega$ , the inputs of the sensing amplifier must high-impedance.

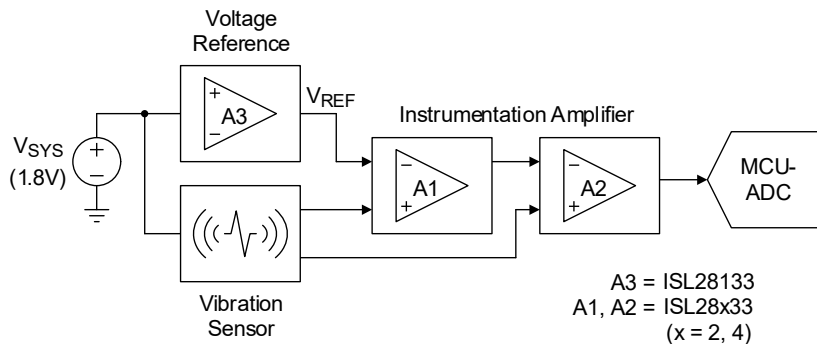

Figure 13. High-Impedance Vibration Sensor Amplification with Instrumentation Amplifier

For this purpose, A1 and A2 form a 2-amp instrumentation amplifier, whose high-impedance, non-inverting inputs detect the sensor signal.

A3 is configured as a reference voltage buffer that sets the DC mid-voltage around which the amplified sensor signal swings.

### 4.3 Low-Side Current Sensing in a Motor Drive for AC-Induction Motors

Figure 14 shows the principle of low-side current sensing in AC motor drives. Here, the load current creates a voltage across a sense resistor of  $V_S = I_L \times R_S$ , which is amplified and then applied to the ADC input.

This application often requires fast switching op-amps (high slew rates) to detect frequent current transients during operation.

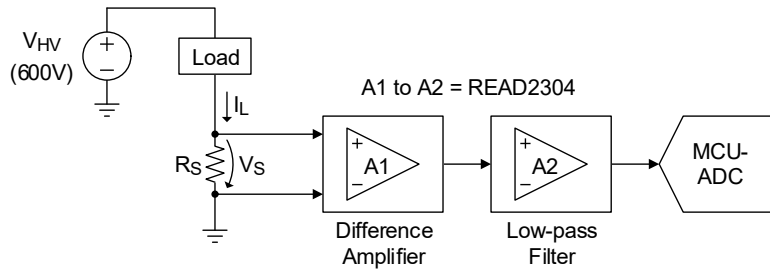

Figure 14. High-Voltage, Low-Side Current Sensing with Fast Op-amps

A1 is configured as a difference amplifier of the resistive type (Figure 8).

A2 is configured as a low-pass filter to remove high-frequency noise.

### 4.4 High-Voltage High-Side Current Sensing in Motor Drives for DC Motors

Figure 15 depicts a high-side current sensing application in high-voltage systems ( $V_{HV} = 150V$ ) without integrated current sensing ICs. Low-voltage op-amps perform signal amplification and filtering. Here, the op-amp supply of  $\leq 5V$  is derived from the 150V system supply via a 4.7V Zener diode,  $D_Z$ , which sets the supply span from 150V to 145.3V.

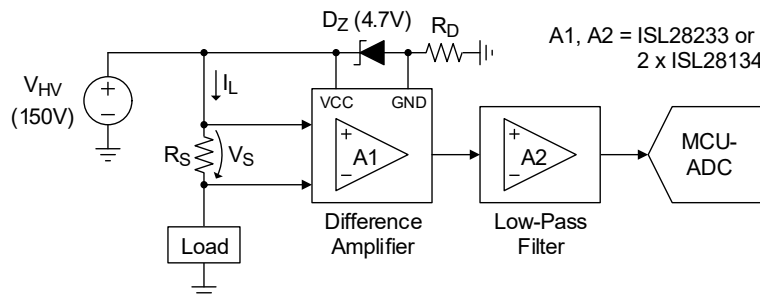

Figure 15. High-Voltage, High-Side Current Sensing

The load current is defined by the system supply and the load impedance using  $I_L = V_{HV} / Z_{Load}$ . A sense resistor,  $R_S \ll Z_{Load}$ , creates the sense voltage,  $V_S = I_L \times R_S$ , which is measured and filtered.

A1 is configured as a difference amplifier with transistor feedback (Figure 9).

A2 is configured as a low-pass filter to remove high-frequency noise.

## 5. Conclusion

Part 1 presented the op-amp as a basic analog building block that requires configuration through external components, such as resistors, capacitors, and transistors, to perform various functions, including signal generation, amplification, filtering, and arithmetic operations.

Part 2 explains the key parameters designers consider when selecting op-amps for specific applications.

## 6. Revision History

Revision	Date	Description
1.00	May 11, 2023	Initial release.

## IMPORTANT NOTICE AND DISCLAIMER

RENESAS ELECTRONICS CORPORATION AND ITS SUBSIDIARIES (“RENESAS”) PROVIDES TECHNICAL SPECIFICATIONS AND RELIABILITY DATA (INCLUDING DATASHEETS), DESIGN RESOURCES (INCLUDING REFERENCE DESIGNS), APPLICATION OR OTHER DESIGN ADVICE, WEB TOOLS, SAFETY INFORMATION, AND OTHER RESOURCES “AS IS” AND WITH ALL FAULTS, AND DISCLAIMS ALL WARRANTIES, EXPRESS OR IMPLIED, INCLUDING, WITHOUT LIMITATION, ANY IMPLIED WARRANTIES OF MERCHANTABILITY, FITNESS FOR A PARTICULAR PURPOSE, OR NON-INFRINGEMENT OF THIRD PARTY INTELLECTUAL PROPERTY RIGHTS.

These resources are intended for developers skilled in the art designing with Renesas products. You are solely responsible for (1) selecting the appropriate products for your application, (2) designing, validating, and testing your application, and (3) ensuring your application meets applicable standards, and any other safety, security, or other requirements. These resources are subject to change without notice. Renesas grants you permission to use these resources only for development of an application that uses Renesas products. Other reproduction or use of these resources is strictly prohibited. No license is granted to any other Renesas intellectual property or to any third party intellectual property. Renesas disclaims responsibility for, and you will fully indemnify Renesas and its representatives against, any claims, damages, costs, losses, or liabilities arising out of your use of these resources. Renesas' products are provided only subject to Renesas' Terms and Conditions of Sale or other applicable terms agreed to in writing. No use of any Renesas resources expands or otherwise alters any applicable warranties or warranty disclaimers for these products.

(Disclaimer Rev.1.0 Mar 2020)

### Corporate Headquarters

TOYOSU FORESIA, 3-2-24 Toyosu,  
Koto-ku, Tokyo 135-0061, Japan  
[www.renesas.com](http://www.renesas.com)

### Contact Information

For further information on a product, technology, the most up-to-date version of a document, or your nearest sales office, please visit:  
[www.renesas.com/contact/](http://www.renesas.com/contact/)

### Trademarks

Renesas and the Renesas logo are trademarks of Renesas Electronics Corporation. All trademarks and registered trademarks are the property of their respective owners.