

GENERAL DESCRIPTION

The ICS874003I-02 is a high performance Differential-to-LVDS Jitter Attenuator designed for use in PCI Express systems. In some PCI Express systems, such as those found in desktop PCs, the PCI Express clocks are generated from a low bandwidth, high phase noise PLL frequency synthesizer. In these systems, a jitter attenuator may be required to attenuate high frequency random and deterministic jitter components from the PLL synthesizer and from the system board. The ICS874003I-02 has a bandwidth of 400kHz. The 400kHz provides an intermediate bandwidth that can easily track triangular spread profiles, while providing good jitter attenuation.

The ICS874003I-02 uses IDT's 3rd Generation FemtoClock™ PLL technology to achieve the lowest possible phase noise. The device is packaged in a 20 Lead TSSOP package, making it ideal for use in space constrained applications such as PCI Express add-in cards.

FEATURES

- Three Differential LVDS output pairs
- One Differential clock input
- CLK and nCLK supports the following input types: LVPECL, LVDS, LVHSTL, SSTL, HCSL
- Output frequency range: 98MHz - 320MHz
- Input frequency range: 98MHz - 128MHz
- VCO range: 490MHz - 640MHz
- Cycle-to-cycle jitter: 35ps (maximum)
- Supports PCI-Express Spread-Spectrum Cloning
- The 400kHz bandwidth mode allows the system designer to make jitter attenuation/tracking skew design trade-offs
- 3.3V operating supply
- -40°C to 85°C ambient operating temperature
- Lead-free (RoHS 6) packaging

F_SEL[2:0] FUNCTION TABLE

Inputs			Outputs	
F_SEL2	F_SEL1	F_SEL0	QA0, nQA0:QA1, nQA1	QB0, nQB0
0	0	0	÷2	÷2
1	0	0	÷5	÷2
0	1	0	÷4	÷2
1	1	0	÷2	÷4
0	0	1	÷2	÷5
1	0	1	÷5	÷4
0	1	1	÷4	÷5
1	1	1	÷4	÷4

BLOCK DIAGRAM

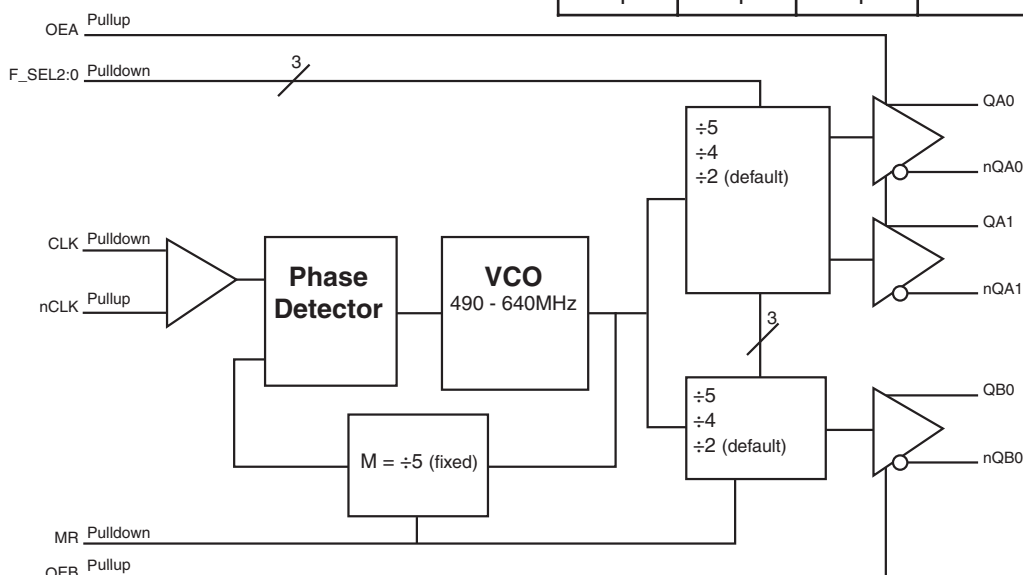

PIN ASSIGNMENT

QA1	1	20	nQA1
VDD0	2	19	VDD0
QA0	3	18	QB0
nQA0	4	17	nQB0
MR	5	16	F_SEL2
F_SEL0	6	15	OEB
nc	7	14	GND
VDDA	8	13	nCLK
F_SEL1	9	12	CLK
VDD	10	11	OEA

ICS874003I-02 20-Lead TSSOP

6.5mm x 4.4mm x 0.92mm
package body
G Package
Top View

TABLE 1. PIN DESCRIPTIONS

Number	Name	Type		Description
1, 20	QA1, nQA1	Output		Differential output pair. LVDS interface levels.
2, 19	V _{DDO}	Power		Output supply pins.
3, 4	QA0, nQA0	Output		Differential output pair. LVDS interface levels.
5	MR	Input	Pulldown	Active HIGH Master Reset. When logic HIGH, the internal dividers are reset causing the true outputs (nQx) to go low and the inverted outputs (Qx) to go high. When logic LOW, the internal dividers and the outputs are enabled. LVCMOS/LVTTL interface levels.
6, 9, 16	F_SELO, F_SEL1, F_SEL2	Input	Pulldown	Frequency select pin for QAx/nQAx and QBx0/nQB0 outputs. LVCMOS/LVTTL interface levels.
7	nc	Unused		No connect.
8	V _{DDA}	Power		Analog supply pin.
10	V _{DD}	Power		Core supply pin.
11	OEA	Input	Pullup	Output enable pin for QA pins. When HIGH, the QAx/nQAx outputs are active. When LOW, the QAx/nQAx outputs are in a high impedance state. LVCMOS/LVTTL interface levels.
12	CLK	Input	Pulldown	Non-inverting differential clock input.
13	nCLK	Input	Pullup	Inverting differential clock input.
14	GND	Power		Power supply ground.
15	OEB	Input	Pullup	Output enable pin for QB pins. When HIGH, the QBx/nQBx outputs are active. When LOW, the QBx/nQBx outputs are in a high impedance state. LVCMOS/LVTTL interface levels.
17, 18	nQB0, QB0	Output		Differential output pair. LVDS interface levels.

NOTE: *Pullup* and *Pulldown* refer to internal input resistors. See Table 2, Pin Characteristics, for typical values.

TABLE 2. PIN CHARACTERISTICS

Symbol	Parameter	Test Conditions	Minimum	Typical	Maximum	Units
C _{IN}	Input Capacitance			4		pF
R _{PULLUP}	Input Pullup Resistor			51		kΩ
R _{PULLDOWN}	Input Pulldown Resistor			51		kΩ

TABLE 3. OUTPUT ENABLE FUNCTION TABLE

Inputs		Outputs	
OEA	OEB	QA0/nQA0, QA1/nQA1	QB0/nQB0
0	0	HiZ	HiZ
1	1	Enabled	Enabled

ABSOLUTE MAXIMUM RATINGS

Supply Voltage, V_{DD}	4.6V
Inputs, V_I	-0.5V to $V_{DD} + 0.5V$
Outputs, V_O	-0.5V to $V_{DDO} + 0.5V$
Package Thermal Impedance, θ_{JA}	73.2°C/W (0 lfpm)
Storage Temperature, T_{STG}	-65°C to 150°C

NOTE: Stresses beyond those listed under Absolute Maximum Ratings may cause permanent damage to the device. These ratings are stress specifications only. Functional operation of product at these conditions or any conditions beyond those listed in the *DC Characteristics* or *AC Characteristics* is not implied. Exposure to absolute maximum rating conditions for extended periods may affect product reliability.

TABLE 4A. POWER SUPPLY DC CHARACTERISTICS, $V_{DD} = V_{DDA} = V_{DDO} = 3.3V \pm 5\%$, $T_A = -40^\circ C$ TO $85^\circ C$

Symbol	Parameter	Test Conditions	Minimum	Typical	Maximum	Units
V_{DD}	Core Supply Voltage		3.135	3.3	3.465	V
V_{DDA}	Analog Supply Voltage		$V_{DD} - 0.12$	3.3	V_{DD}	V
V_{DDO}	Output Supply Voltage		3.135	3.3	3.465	V
I_{DD}	Power Supply Current				75	mA
I_{DDA}	Analog Supply Current				12	mA
I_{DDO}	Output Supply Current				75	mA

TABLE 4B. LVCMOS/LVTTL DC CHARACTERISTICS, $V_{DD} = V_{DDA} = V_{DDO} = 3.3V \pm 5\%$, $T_A = -40^\circ C$ TO $85^\circ C$

Symbol	Parameter	Test Conditions	Minimum	Typical	Maximum	Units
V_{IH}	Input High Voltage		2		$V_{DD} + 0.3$	V
V_{IL}	Input Low Voltage		-0.3		0.8	V
I_{IH}	Input High Current	OEA, OEB	$V_{DD} = V_{IN} = 3.465V$		5	μA
		F_SEL0, F_SEL1 F_SEL2, MR	$V_{DD} = V_{IN} = 3.465V$		150	μA
I_{IL}	Input Low Current	OEA, OEB	$V_{DD} = 3.465V, V_{IN} = 0V$	-150		μA
		F_SEL0, F_SEL1 F_SEL2, MR	$V_{DD} = 3.465V, V_{IN} = 0V$	-5		μA

TABLE 4C. DIFFERENTIAL DC CHARACTERISTICS, $V_{DD} = V_{DDA} = V_{DDO} = 3.3V \pm 5\%$, $T_A = -40^\circ C$ TO $85^\circ C$

Symbol	Parameter	Test Conditions	Minimum	Typical	Maximum	Units
I_{IH}	Input High Current	CLK	$V_{DD} = V_{IN} = 3.465V$		150	μA
		nCLK	$V_{DD} = V_{IN} = 3.465V$	5		
I_{IL}	Input Low Current	CLK	$V_{DD} = V_{IN} = 3.465V$		150	μA
		nCLK	$V_{DD} = V_{IN} = 3.465V$	-150		
V_{PP}	Peak-to-Peak Input Voltage		0.15		1.3	V
V_{CMR}	Common Mode Input Voltage; NOTE 1, 2		GND + 0.5		$V_{DD} - 0.85$	V

NOTE 1: Common mode voltage is defined as V_{IH} .

NOTE 2: For single ended applications, the maximum input voltage for CLK, nCLK and FB_IN, nFB_IN is $V_{DD} + 0.3V$.

TABLE 4D. LVDS DC CHARACTERISTICS, $V_{DD} = V_{DDA} = V_{DDO} = 3.3V \pm 5\%$, $T_A = -40^\circ\text{C}$ TO 85°C

Symbol	Parameter	Test Conditions	Minimum	Typical	Maximum	Units
V_{OD}	Differential Output Voltage		275	375	485	mV
ΔV_{OD}	V_{OD} Magnitude Change				50	mV
V_{OS}	Offset Voltage		1.2	1.35	1.5	V
ΔV_{OS}	V_{OS} Magnitude Change				50	mV

TABLE 5. AC CHARACTERISTICS, $V_{DD} = V_{DDA} = V_{DDO} = 3.3V \pm 5\%$, $T_A = -40^\circ\text{C}$ TO 85°C

Symbol	Parameter	Test Conditions	Minimum	Typical	Maximum	Units
f_{MAX}	Output Frequency		98		320	MHz
$f_{jit}(cc)$	Cycle-to-Cycle Jitter, NOTE 1				35	ps
$t_{sk}(o)$	Output Skew; NOTE 2, 3				145	ps
$t_{sk}(b)$	Bank Skew; NOTE 1, 4	Bank A			55	ps
t_R / t_F	Output Rise/Fall Time	20% to 80%	275		725	ps
odc	Output Duty Cycle		47		53	%

NOTE 1: This parameter is defined in accordance with JEDEC Standard 65.

NOTE 2: Defined as skew between outputs at the same supply voltage and with equal load conditions.

Measured at $V_{DDO}/2$.

NOTE 3: These parameters are guaranteed by characterization. Not tested in production.

NOTE 4: Defined as skew within a bank of outputs at the same voltages and with equal load conditions.

PARAMETER MEASUREMENT INFORMATION

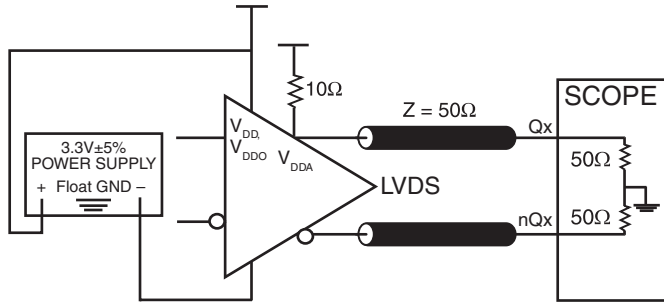

3.3V LVDS OUTPUT LOAD AC TEST CIRCUIT

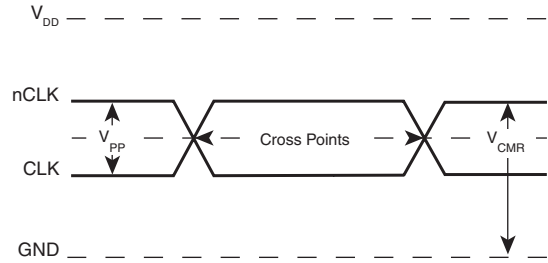

DIFFERENTIAL INPUT LEVEL

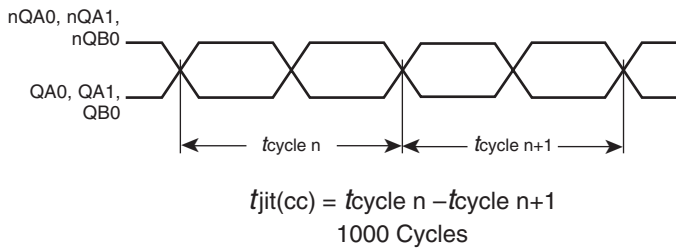

CYCLE-TO-CYCLE JITTER

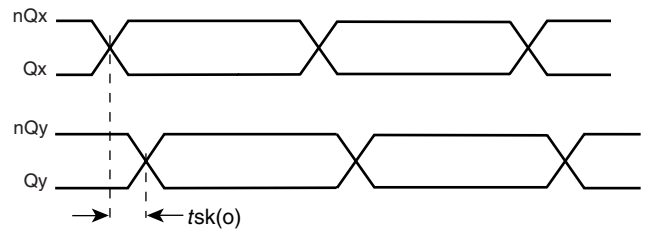

OUTPUT SKEW

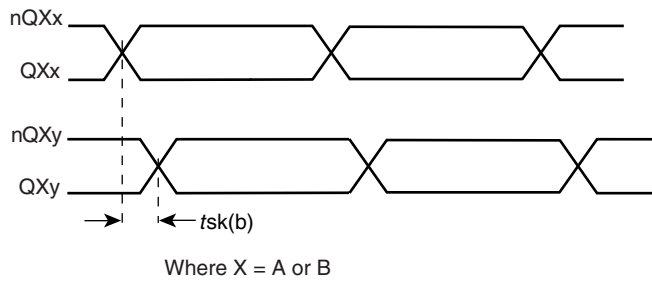

BANK SKEW

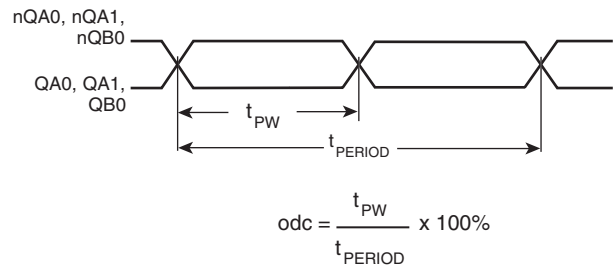

OUTPUT DUTY CYCLE/PULSE WIDTH/PERIOD

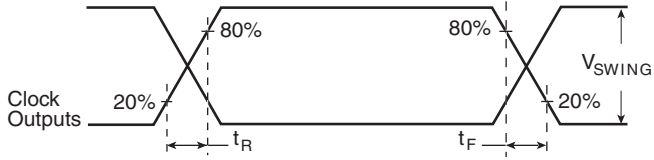

OUTPUT RISE/FALL TIME

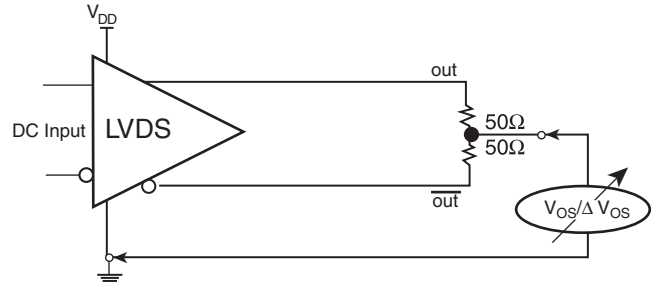

OFFSET VOLTAGE SETUP

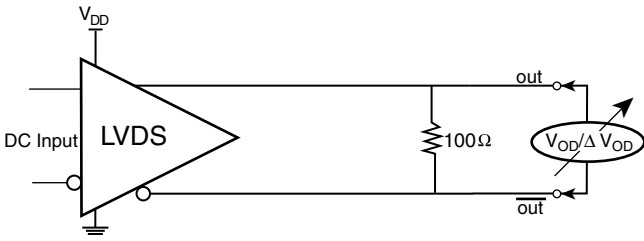

DIFFERENTIAL OUTPUT VOLTAGE SETUP

APPLICATION INFORMATION

POWER SUPPLY FILTERING TECHNIQUES

As in any high speed analog circuitry, the power supply pins are vulnerable to random noise. The ICS874003I-02 provides separate power supplies to isolate any high switching noise from the outputs to the internal PLL. V_{DD} , V_{DDA} , and V_{DDO} should be individually connected to the power supply plane through vias, and bypass capacitors should be used for each pin. To achieve optimum jitter performance, power supply isolation is required. *Figure 1* illustrates how a 10Ω resistor along with a $10\mu\text{F}$ and a $0.01\mu\text{F}$ bypass capacitor should be connected to each V_{CCA} pin.

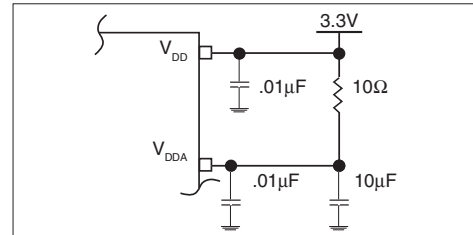

FIGURE 1. POWER SUPPLY FILTERING

WIRING THE DIFFERENTIAL INPUT TO ACCEPT SINGLE ENDED LEVELS

Figure 2 shows how the differential input can be wired to accept single ended levels. The reference voltage $V_{REF} = V_{DD}/2$ is generated by the bias resistors R1, R2 and C1. This bias circuit should be located as close as possible to the input pin. The ratio of

R1 and R2 might need to be adjusted to position the V_{REF} in the center of the input voltage swing. For example, if the input clock swing is only 2.5V and $V_{DD} = 3.3\text{V}$, V_{REF} should be 1.25V and $R2/R1 = 0.609$.

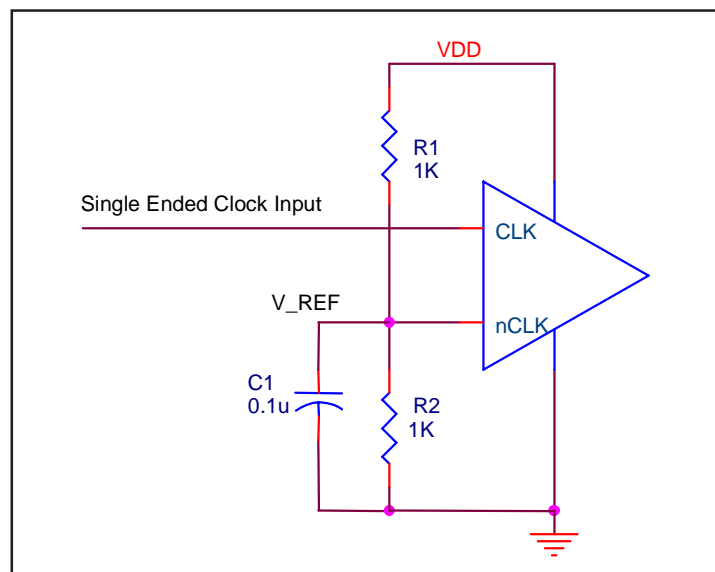

FIGURE 2. SINGLE ENDED SIGNAL DRIVING DIFFERENTIAL INPUT

DIFFERENTIAL CLOCK INPUT INTERFACE

The CLK /nCLK accepts LVDS, LVPECL, LVHSTL, SSTL, HCSTL and other differential signals. Both V_{SWING} and V_{OH} must meet the V_{PP} and V_{CMR} input requirements. Figures 3A to 3D show interface examples for the HiPerClockS CLK/nCLK input driven by the most common driver types. The input interfaces suggested here are

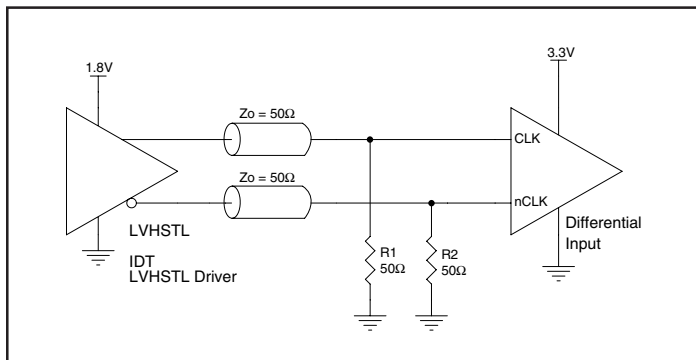

FIGURE 3A. CLK/nCLK INPUT DRIVEN BY ICS LVHSTL DRIVER

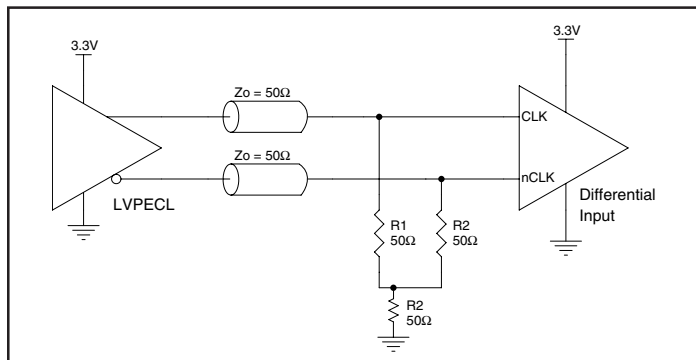

FIGURE 3B. CLK/nCLK INPUT DRIVEN BY 3.3V LVPECL DRIVER

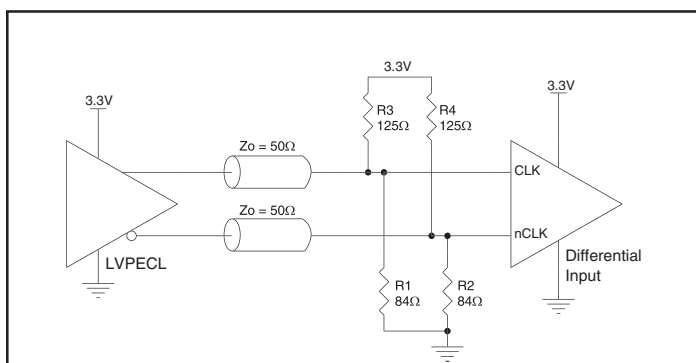

FIGURE 3C. CLK/nCLK INPUT DRIVEN BY 3.3V LVPECL DRIVER

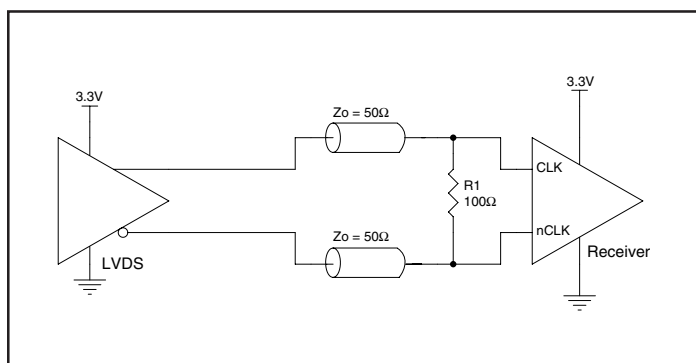

FIGURE 3D. CLK/nCLK INPUT DRIVEN BY 3.3V LVDS DRIVER

RECOMMENDATIONS FOR UNUSED INPUT AND OUTPUT PINS

INPUTS:

LVC MOS CONTROL PINS:

All control pins have internal pull-ups or pull-downs; additional resistance is not required but can be added for additional protection. A 1kΩ resistor can be used.

OUTPUTS:

LVDS

All unused LVDS output pairs can be either left floating or terminated with 100Ω across. If they are left floating, we recommend that there is no trace attached.

LVDS DRIVER TERMINATION

A general LVDS interface is shown in *Figure 4*. In a 100Ω differential transmission line environment, LVDS drivers require a matched load termination of 100Ω across near the

receiver input. For a multiple LVDS outputs buffer, if only partial outputs are used, it is recommended to terminate the unused outputs.

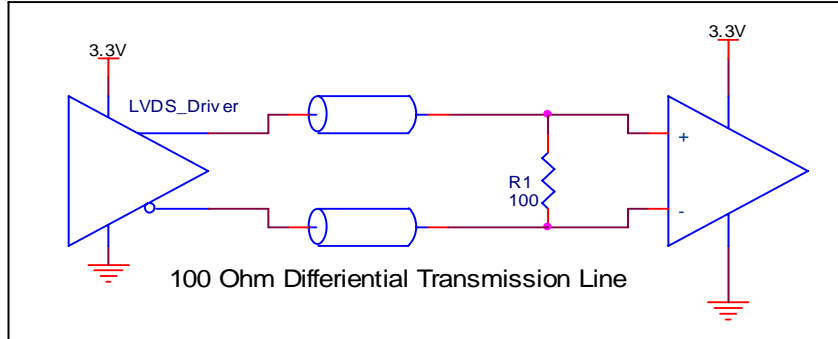

FIGURE 4. TYPICAL LVDS DRIVER TERMINATION

POWER CONSIDERATIONS

This section provides information on power dissipation and junction temperature for the ICS874003I-02. Equations and example calculations are also provided.

1. Power Dissipation.

The total power dissipation for the ICS874003I-02 is the sum of the core power plus the power dissipated due to the load. The following is the power dissipation for $V_{DD} = 3.3V + 5\% = 3.465V$, which gives worst case results.

- Power (core)_{MAX} = $V_{DD_MAX} * (I_{DD_MAX} + I_{DDA_MAX}) = 3.465V * (75mA + 12mA) = 301.45mW$
- Power (outputs)_{MAX} = $V_{DDO_MAX} * I_{DDO_MAX} = 3.465V * 75mA = 259.87mW$

$$\text{Total Power}_{MAX} = 301.45mW + 259.87mW = 561.32mW$$

2. Junction Temperature.

Junction temperature, T_j , is the temperature at the junction of the bond wire and bond pad and directly affects the reliability of the device. The maximum recommended junction temperature is 125°C.

The equation for T_j is as follows: $T_j = \theta_{JA} * Pd_total + T_A$

T_j = Junction Temperature

θ_{JA} = Junction-to-Ambient Thermal Resistance

Pd_total = Total Device Power Dissipation (example calculation is in section 1 above)

T_A = Ambient Temperature

In order to calculate junction temperature, the appropriate junction-to-ambient thermal resistance θ_{JA} must be used. Assuming a moderate air flow of 200 linear feet per minute and a multi-layer board, the appropriate value is 66.6°C/W per Table 6 below.

Therefore, T_j for an ambient temperature of 85°C with all outputs switching is:

$$85^\circ\text{C} + 0.561\text{W} * 66.6^\circ\text{C/W} = 122.4^\circ\text{C}. \text{ This is below the limit of } 125^\circ\text{C}.$$

This calculation is only an example. T_j will obviously vary depending on the number of loaded outputs, supply voltage, air flow, and the type of board (single layer or multi-layer).

TABLE 6. THERMAL RESISTANCE θ_{JA} FOR 20-LEAD TSSOP, FORCED CONVECTION

θ_{JA} by Velocity (Linear Feet per Minute)			
	0	200	500
Single-Layer PCB, JEDEC Standard Test Boards	114.5°C/W	98.0°C/W	88.0°C/W
Multi-Layer PCB, JEDEC Standard Test Boards	73.2°C/W	66.6°C/W	63.5°C/W

NOTE: Most modern PCB designs use multi-layered boards. The data in the second row pertains to most designs.

RELIABILITY INFORMATION

TABLE 6. θ_{JA} VS. AIR FLOW TABLE FOR 20 LEAD TSSOP

θ_{JA} by Velocity (Linear Feet per Minute)			
	0	200	500
Single-Layer PCB, JEDEC Standard Test Boards	114.5°C/W	98.0°C/W	88.0°C/W
Multi-Layer PCB, JEDEC Standard Test Boards	73.2°C/W	66.6°C/W	63.5°C/W

NOTE: Most modern PCB designs use multi-layered boards. The data in the second row pertains to most designs.

TRANSISTOR COUNT

The transistor count for ICS874003I-02 is: 1408

PACKAGE OUTLINE - G SUFFIX FOR 20 LEAD TSSOP

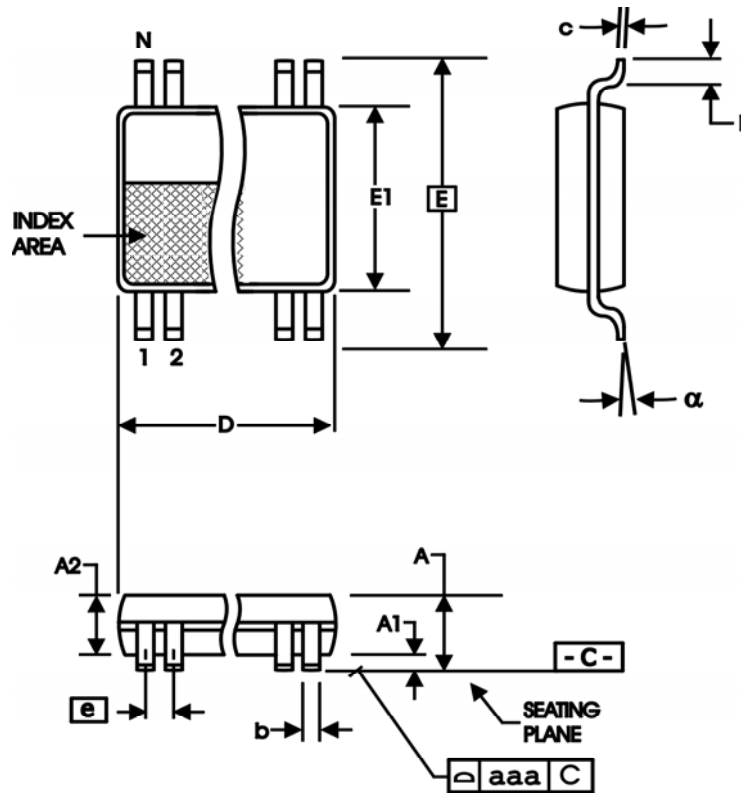

TABLE 7. PACKAGE DIMENSIONS

SYMBOL	Millimeters	
	MIN	MAX
N	20	
A	--	1.20
A1	0.05	0.15
A2	0.80	1.05
b	0.19	0.30
c	0.09	0.20
D	6.40	6.60
E	6.40 BASIC	
E1	4.30	4.50
e	0.65 BASIC	
L	0.45	0.75
α	0°	8°
aaa	--	0.10

Reference Document: JEDEC Publication 95, MO-153

TABLE 8. ORDERING INFORMATION

Part/Order Number	Marking	Package	Shipping Packaging	Temperature
874003AGI-02LF	ICS4003AI02L	20 lead "Lead Free" TSSOP	Tube	-40°C to +85°C
874003AGI-02LFT	ICS4003AI02L	20 lead "Lead Free" TSSOP	Tape and Reel	-40°C to +85°C

TABLE 9. REVISION HISTORY

REV	TABLE	PAGE	CHANGE	DATE
A	Function T	1	Corrected typo 'QA0, nQA0:QA1, nQA1'.	5/1/2013
		1	Removed HiPerClockS logo.	
		8	Removed HiPerClockS references from drawings	
		10	Removed HiPerClockS reference from Power Considerations	

ICS874003-02

PCI EXPRESS™ JITTER ATTENUATOR

IMPORTANT NOTICE AND DISCLAIMER

RENESAS ELECTRONICS CORPORATION AND ITS SUBSIDIARIES (“RENESAS”) PROVIDES TECHNICAL SPECIFICATIONS AND RELIABILITY DATA (INCLUDING DATASHEETS), DESIGN RESOURCES (INCLUDING REFERENCE DESIGNS), APPLICATION OR OTHER DESIGN ADVICE, WEB TOOLS, SAFETY INFORMATION, AND OTHER RESOURCES “AS IS” AND WITH ALL FAULTS, AND DISCLAIMS ALL WARRANTIES, EXPRESS OR IMPLIED, INCLUDING, WITHOUT LIMITATION, ANY IMPLIED WARRANTIES OF MERCHANTABILITY, FITNESS FOR A PARTICULAR PURPOSE, OR NON-INFRINGEMENT OF THIRD-PARTY INTELLECTUAL PROPERTY RIGHTS.

These resources are intended for developers who are designing with Renesas products. You are solely responsible for (1) selecting the appropriate products for your application, (2) designing, validating, and testing your application, and (3) ensuring your application meets applicable standards, and any other safety, security, or other requirements. These resources are subject to change without notice. Renesas grants you permission to use these resources only to develop an application that uses Renesas products. Other reproduction or use of these resources is strictly prohibited. No license is granted to any other Renesas intellectual property or to any third-party intellectual property. Renesas disclaims responsibility for, and you will fully indemnify Renesas and its representatives against, any claims, damages, costs, losses, or liabilities arising from your use of these resources. Renesas' products are provided only subject to Renesas' Terms and Conditions of Sale or other applicable terms agreed to in writing. No use of any Renesas resources expands or otherwise alters any applicable warranties or warranty disclaimers for these products.

(Disclaimer Rev.1.01 Jan 2024)

Corporate Headquarters

TOYOSU FORESIA, 3-2-24 Toyosu,
Koto-ku, Tokyo 135-0061, Japan
www.renesas.com

Trademarks

Renesas and the Renesas logo are trademarks of Renesas Electronics Corporation. All trademarks and registered trademarks are the property of their respective owners.

Contact Information

For further information on a product, technology, the most up-to-date version of a document, or your nearest sales office, please visit www.renesas.com/contact-us/.