

## Low Cost DDR Phase Lock Loop Clock Driver

### Recommended Application:

DDR Clock Driver

### Product Description/Features:

- Low skew, low jitter PLL clock driver
- I<sup>2</sup>C for functional and output control
- Feedback pins for input to output synchronization
- Spread Spectrum tolerant inputs
- **Bypass mode on B revision only**

### Switching Characteristics:

- PEAK - PEAK jitter (66MHz): <75ps
- CYCLE - CYCLE jitter (>100MHz): <65ps
- OUTPUT - OUTPUT skew: <100ps
- Output Rise and Fall Time: 550ps - 950ps

### Pin Configuration

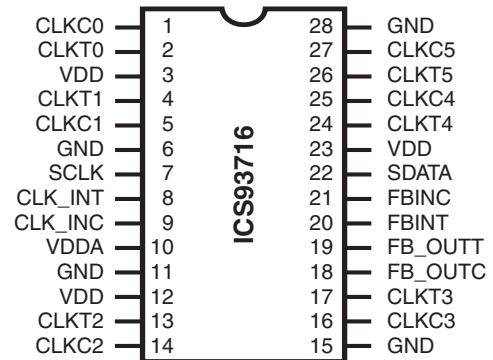

### 28-Pin SSOP and TSSOP

### Functionality

AVDD	INPUTS		OUTPUTS				PLL State
	CLK_INT	CLK_INC	CLKT	CLKC	FB_OUTT	FB_OUTC	
2.5V (nom)	L	H	L	H	L	H	on
2.5V (nom)	H	L	H	L	H	L	on
2.5V (nom)	<20MHz		Z	Z	Z	Z	off
GND	L	H	L	H	L	H	Bypassed/off
GND	H	L	H	L	H	L	Bypassed/off

### Block Diagram

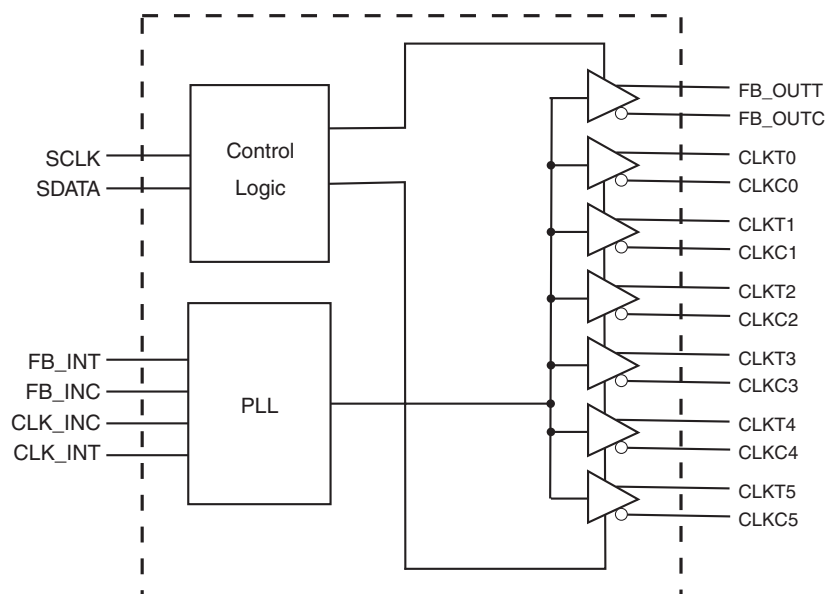

## Pin Descriptions

PIN NUMBER	PIN NAME	TYPE	DESCRIPTION
6, 11, 15, 28	GND	PWR	Ground
27, 25, 16, 14, 5, 1	CLKC(5:0)	OUT	"Complementary" clocks of differential pair outputs.
26, 24, 17, 13, 4, 2	CLKT(5:0)	OUT	"True" Clock of differential pair outputs.
3, 12, 23	VDD	PWR	Power supply 2.5V
7	SCLK	IN	Clock input of I <sup>2</sup> C input, 5V tolerant input
8	CLK_INT	IN	"True" reference clock input
9	CLK_INC	IN	"Complementary" reference clock input
10	VDDA	PWR	Analog power supply, 2.5V
18	FB_OUTC	OUT	"Complementary" Feedback output, dedicated for external feedback. It switches at the same frequency as the CLK. This output must be wired to FB_INC.
19	FB_OUTT	OUT	"True" " Feedback output, dedicated for external feedback. It switches at the same frequency as the CLK. This output must be wired to FB_INT.
20	FB_INT	IN	"True" Feedback input, provides feedback signal to the internal PLL for synchronization with CLK_INT to eliminate phase error.
21	FB_INC	IN	"Complementary" Feedback input, provides signal to the internal PLL for synchronization with CLK_INC to eliminate phase error.
22	SDATA	IN	Data input for I <sup>2</sup> C serial input, 5V tolerant input

**Byte 0: Output Control**  
(1= enable, 0 = disable)

BIT	PIN#	PWD	DESCRIPTION
Bit 7	2, 1	1	CLKT0, CLKC0
Bit 6	4, 5	1	CLKT1, CLKC1
Bit 5	-	1	Reserved
Bit 4	-	1	Reserved
Bit 3	13, 14	1	CLKT2, CLKC2
Bit 2	26, 27	1	CLKT5, CLKC5
Bit 1	-	1	Reserved
Bit 0	24, 25	1	CLKT4, CLKC4

**Byte 1: Output Control**  
(1= enable, 0 = disable)

BIT	PIN#	PWD	DESCRIPTION
Bit 7	-	X	Reserved
Bit 6	17, 16	1	CLKT3, CLKC3
Bit 5	-	X	Reserved
Bit 4	-	X	Reserved
Bit 3	-	X	Reserved
Bit 2	-	X	Reserved
Bit 1	-	X	Reserved
Bit 0	-	X	Reserved

**Byte 2: Reserved**  
(1= enable, 0 = disable)

BIT	PIN#	PWD	DESCRIPTION
Bit 7	-	X	Reserved
Bit 6	-	X	Reserved
Bit 5	-	X	Reserved
Bit 4	-	X	Reserved
Bit 3	-	X	Reserved
Bit 2	-	X	Reserved
Bit 1	-	X	Reserved
Bit 0	-	X	Reserved

**Byte 3: Reserved**  
(1= enable, 0 = disable)

BIT	PIN#	PWD	DESCRIPTION
Bit 7	-	X	Reserved
Bit 6	-	X	Reserved
Bit 5	-	X	Reserved
Bit 4	-	X	Reserved
Bit 3	-	X	Reserved
Bit 2	-	X	Reserved
Bit 1	-	X	Reserved
Bit 0	-	X	Reserved

**Byte 4: Reserved**  
(1= enable, 0 = disable)

BIT	PIN#	PWD	DESCRIPTION
Bit 7	-	X	Reserved
Bit 6	-	X	Reserved
Bit 5	-	X	Reserved
Bit 4	-	X	Reserved
Bit 3	-	X	Reserved
Bit 2	-	X	Reserved
Bit 1	-	X	Reserved
Bit 0	-	X	Reserved

**Byte 5: Reserved**  
(1= enable, 0 = disable)

BIT	PIN#	PWD	DESCRIPTION
Bit7	-	0	Reserved (Note)
Bit6	-	0	Reserved (Note)
Bit5	-	0	Reserved (Note)
Bit4	-	0	Reserved (Note)
Bit3	-	0	Reserved (Note)
Bit2	-	1	Reserved (Note)
Bit1	-	1	Reserved (Note)
Bit0	-	0	Reserved (Note)

**Note: Don't write into this register, writing into this register can cause malfunction**

## Absolute Maximum Ratings

Supply Voltage (VDD & AVDD)	-0.5V to 4.6V
Logic Inputs	GND - 0.5V to V <sub>DD</sub> + 0.5V
Ambient Operating Temperature	0°C to +85°C
Storage Temperature	-65°C to +150°C

Stresses above those listed under *Absolute Maximum Ratings* may cause permanent damage to the device. These ratings are stress specifications only and functional operation of the device at these or any other conditions above those listed in the operational sections of the specifications is not implied. Exposure to absolute maximum rating conditions for extended periods may affect product reliability.

## Electrical Characteristics - Input/Supply/Common Output Parameters

T<sub>A</sub> = 0 - 85°C; Supply Voltage AVDD, VDD = 2.5 V +/- 0.2V, R<sub>L</sub> = 120Ω, C<sub>L</sub>=15pF (unless otherwise stated)

PARAMETER	SYMBOL	CONDITIONS	MIN	TYP	MAX	UNITS
Input High Current	I <sub>IH</sub>	V <sub>I</sub> = V <sub>DD</sub> or GND	5			μA
Input Low Current	I <sub>IL</sub>	V <sub>I</sub> = V <sub>DD</sub> or GND			5	μA
Operating Supply Current	I <sub>DD2.5</sub>	R <sub>L</sub> = 120Ω, C <sub>L</sub> = 0pf @ 170MHz		250	350	mA
	I <sub>DDPD</sub>	C <sub>L</sub> = 0pf		65	90	mA
Input Clamp Voltage	V <sub>IK</sub>	V <sub>DDQ</sub> = 2.3V I <sub>in</sub> = -18mA			-1.2	V
High-level output voltage	V <sub>OH</sub>	I <sub>OH</sub> = -1 mA	V <sub>DD</sub> - 0.1			V
		I <sub>OH</sub> = -12 mA	1.7			V
Low-level output voltage	V <sub>OL</sub>	I <sub>OL</sub> =1 mA			0.1	V
		I <sub>OL</sub> =12 mA			0.6	V
Input Capacitance <sup>1</sup>	C <sub>IN</sub>	V <sub>I</sub> = GND or V <sub>DD</sub>		3		pF
Output Capacitance <sup>1</sup>	C <sub>OUT</sub>	V <sub>OUT</sub> = GND or V <sub>DD</sub>		3		pF

<sup>1</sup>Guaranteed by design at 233MHz, not 100% tested in production.

## DC Electrical Characteristics (see note1)

$T_A = 0 - 85^{\circ}\text{C}$ ; Supply Voltage AVDD, VDD = 2.5 V +/- 0.2V (unless otherwise stated)

PARAMETER	SYMBOL	CONDITIONS	MIN	TYP	MAX	UNITS
Supply Voltage	$V_{DDQ}, A_{VDD}$		2.3	2.5	2.7	V
Low level input voltage	$V_{IL}$	CLK_INT, CLK_INC, FB_INC, FB_INT		0.4	$V_{DD}/2 - 0.18$	V
		SCLK, SDATA	-0.3		0.7	V
High level input voltage	$V_{IH}$	CLK_INT, CLK_INC, FB_INC, FB_INT	$V_{DD}/2 + 0.18$	2.1		V
		SCLK, SDATA	1.7		5	V
DC input signal voltage (note 2)	$V_{IN}$		-0.3		$V_{DD} + 0.3$	V
Differential input signal voltage (note 3)	$V_{ID}$	DC - CLK_INT, CLK_INC, FB_INC, FB_INT	0.36		$V_{DD} + 0.6$	V
		AC - CLK_INT, CLK_INC, FB_INC, FB_INT	0.7		$V_{DD} + 0.6$	V
Output differential cross-voltage (note 4)	$V_{OX}$		$V_{DD}/2 - 0.15$		$V_{DD}/2 + 0.15$	V
Input differential cross-voltage (note 4)	$V_{IX}$		$V_{DD}/2 - 0.2$	$V_{DD}/2$	$V_{DD}/2 + 0.2$	V
High Impedance Output Current	$I_{OZ}$	$V_{DD}=2.7\text{V}, V_{OUT}=V_{DD}$ or GND		0.1	$\pm 5$	$\mu\text{A}$
Operating free-air temperature	$T_A$		0		85	$^{\circ}\text{C}$

### Notes:

- Unused inputs must be held high or low to prevent them from floating.
- DC input signal voltage specifies the allowable DC excursion of differential input.
- Differential inputs signal voltages specifies the differential voltage [VTR-VCP] required for switching, where VTR is the true input level and VCP is the complementary input level.
- Differential cross-point voltage is expected to track variations of  $V_{DD}$  and is the voltage at which the differential signal crosses.

## Timing Requirements

$T_A = 0 - 85^\circ\text{C}$ ; Supply Voltage AVDD, VDD = 2.5 V +/- 0.2V,  $R_L = 120\Omega$ ,  $C_L = 15\text{pF}$  (unless otherwise

PARAMETER	SYMBOL	CONDITIONS	MIN	MAX	UNITS
Max clock frequency <sup>3</sup>	freq <sub>op</sub>		33	233	MHz
Application Frequency Range <sup>3</sup>	freq <sub>App</sub>		60	170	MHz
Input clock duty cycle	d <sub>tin</sub>		40	60	%
CLK stabilization	T <sub>STAB</sub>			100	μs

## Switching Characteristics

$T_A = 0 - 85^\circ\text{C}$ ; Supply Voltage AVDD, VDD = 2.5 V +/- 0.2V,  $R_L = 120\Omega$ ,  $C_L = 15\text{pF}$  (unless otherwise stated)

PARAMETER	SYMBOL	CONDITION	MIN	TYP	MAX	UNITS
Low-to high level propagation delay time	t <sub>PLH</sub> <sup>1</sup>	CLK_IN to any output		5.5		ns
High-to low level propagation delay time	t <sub>PHL</sub> <sup>1</sup>	CLK_IN to any output		5.5		ns
Duty Cycle	DC		49		51	%
Input clock slew rate	t <sub>sl(l)</sub>		1		4	v/ns
Cycle to Cycle Jitter <sup>1</sup>	t <sub>cyc</sub> -t <sub>cyc</sub>	100MHz < f < 170MHz		50	65	ps
Cycle to Cycle Jitter <sup>1</sup>	t <sub>cyc</sub> -t <sub>cyc</sub>	f=66MHz		72	75	ps
Phase error	t <sub>(phase error)</sub> <sup>4</sup>		-150	0	150	ps
Output to Output Skew	t <sub>skew</sub>			75	100	ps
Rise Time, Fall Time	t <sub>r</sub> , t <sub>f</sub>	See figure 8	550		950	ps

### Notes:

1. Refers to transition on noninverting output in PLL bypass mode.
2. While the pulse skew is almost constant over frequency, the duty cycle error increases at higher frequencies. This is due to the formula: duty cycle=t<sub>WH</sub>/t<sub>c</sub>, where the cycle (t<sub>c</sub>) decreases as the frequency goes up.
3. Switching characteristics guaranteed for application frequency range.
4. Static phase offset shifted by design.

Parameter Measurement Information

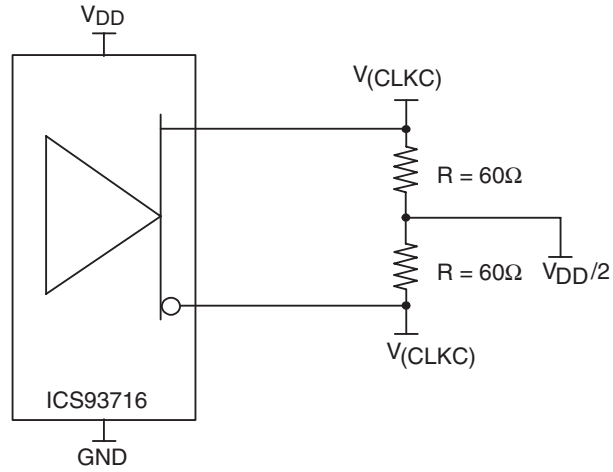
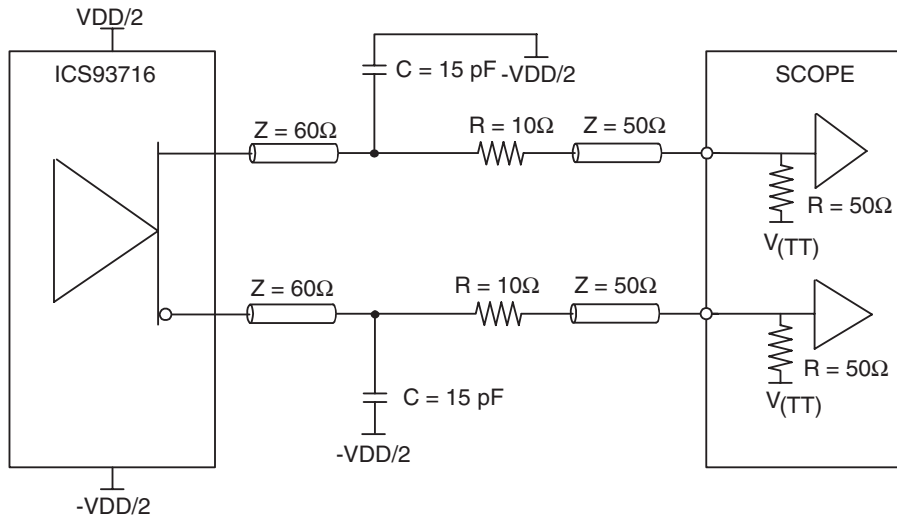

Figure 1. IBIS Model Output Load



NOTE:  $V_{(TT)} = \text{GND}$

Figure 2. Output Load Test Circuit

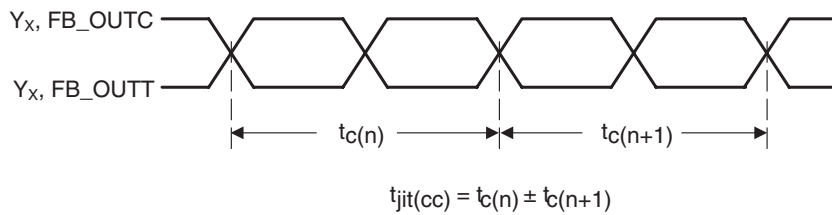

Figure 3. Cycle-to-Cycle Jitter

Parameter Measurement Information

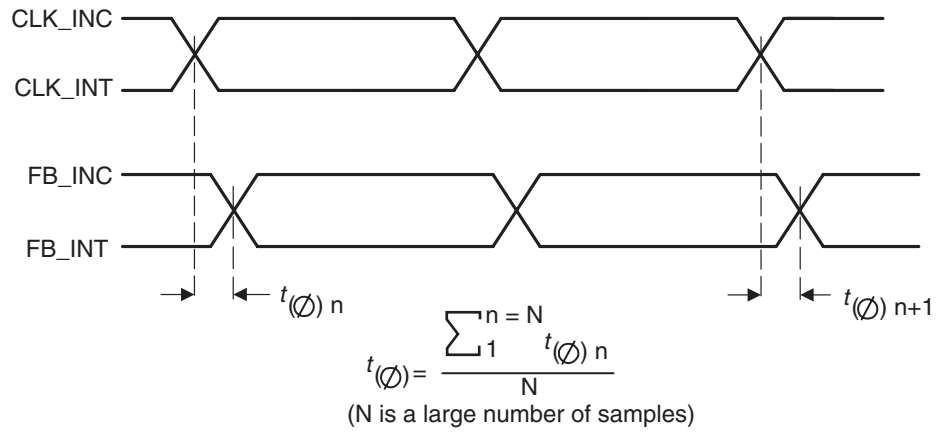

Figure 4. Static Phase Offset

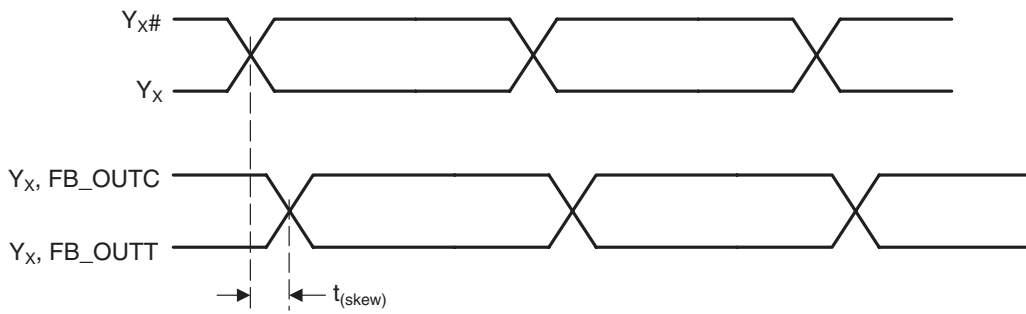

Figure 5. Output Skew

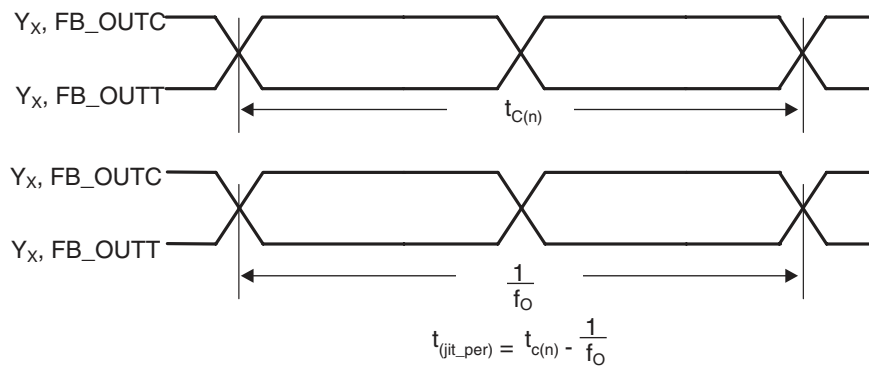

Figure 6. Period Jitter



Parameter Measurement Information

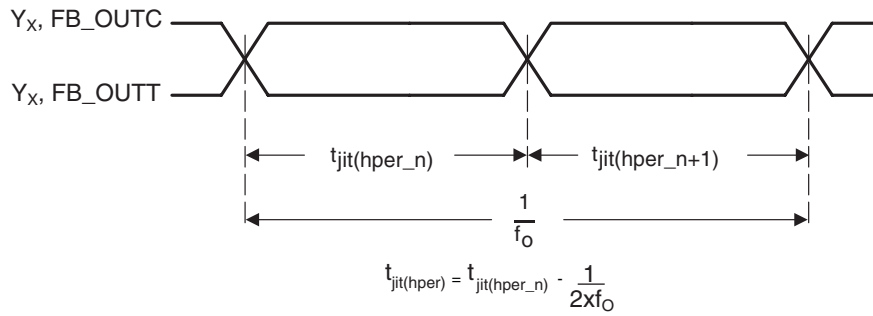

Figure 7. Half-Period Jitter

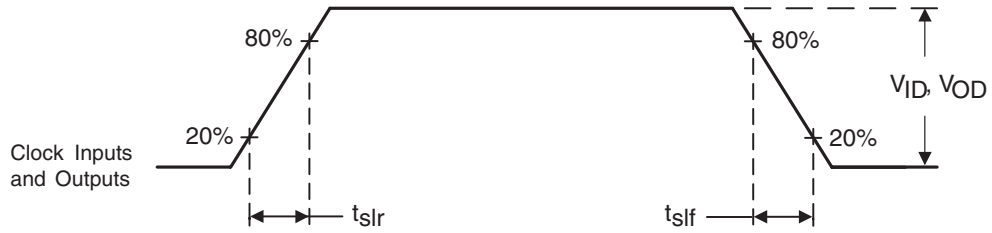

Figure 8. Input and Output Slew Rates

## General I<sup>2</sup>C serial interface information

The information in this section assumes familiarity with I<sup>2</sup>C programming.  
For more information, contact ICS for an I<sup>2</sup>C programming application note.

### How to Write:

- Controller (host) sends a start bit.
- Controller (host) sends the write address D2<sub>(H)</sub>
- ICS clock will *acknowledge*
- Controller (host) sends a dummy command code
- ICS clock will *acknowledge*
- Controller (host) sends a dummy byte count
- ICS clock will *acknowledge*
- Controller (host) starts sending first byte (Byte 0) through byte 5
- ICS clock will *acknowledge* each byte *one at a time*.
- Controller (host) sends a Stop bit

How to Write:	
Controller (Host)	ICS (Slave/Receiver)
Start Bit	
Address D2 <sub>(H)</sub>	
	<b>ACK</b>
Dummy Command Code	
	<b>ACK</b>
Dummy Byte Count	
	<b>ACK</b>
Byte 0	
	<b>ACK</b>
Byte 1	
	<b>ACK</b>
Byte 2	
	<b>ACK</b>
Byte 3	
	<b>ACK</b>
Byte 4	
	<b>ACK</b>
Byte 5	
	<b>ACK</b>
Stop Bit	

### How to Read:

- Controller (host) will send start bit.
- Controller (host) sends the read address D3<sub>(H)</sub>
- ICS clock will *acknowledge*
- ICS clock will send the *byte count*
- Controller (host) acknowledges
- ICS clock sends first byte (*Byte 0*) through *byte 5*
- Controller (host) will need to acknowledge each byte
- Controller (host) will send a stop bit

How to Read:	
Controller (Host)	ICS (Slave/Receiver)
Start Bit	
Address D3 <sub>(H)</sub>	
	<b>ACK</b>
	<b>Byte Count</b>
ACK	
	<b>Byte 0</b>
ACK	
	<b>Byte 1</b>
ACK	
	<b>Byte 2</b>
ACK	
	<b>Byte 3</b>
ACK	
	<b>Byte 4</b>
ACK	
	<b>Byte 5</b>
ACK	
Stop Bit	

### Notes:

1. The ICS clock generator is a slave/receiver, I<sup>2</sup>C component. It can read back the data stored in the latches for verification. **Read-Back will support Intel PIIX4 "Block-Read" protocol.**
2. The data transfer rate supported by this clock generator is 100K bits/sec or less (standard mode)
3. The input is operating at 3.3V logic levels.
4. The data byte format is 8 bit bytes.
5. To simplify the clock generator I<sup>2</sup>C interface, the protocol is set to use only "**Block-Writes**" from the controller. The bytes must be accessed in sequential order from lowest to highest byte with the ability to stop after any complete byte has been transferred. The Command code and Byte count shown above must be sent, but the data is ignored for those two bytes. The data is loaded until a Stop sequence is issued.
6. At power-on, all registers are set to a default condition, as shown.

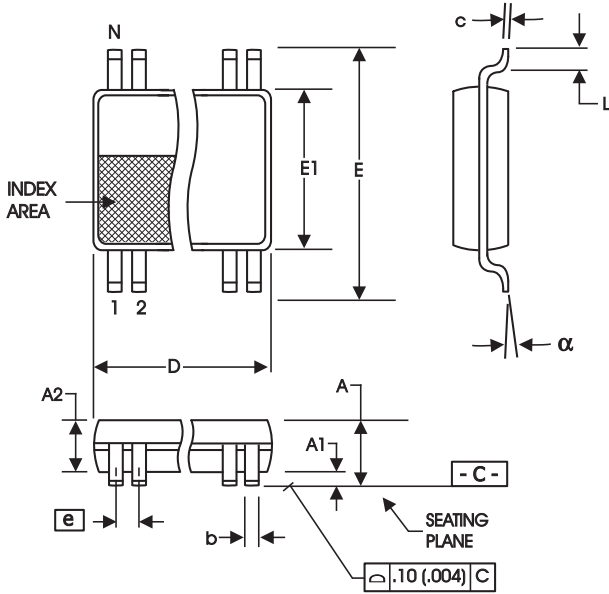

SYMBOL	In Millimeters		In Inches	
	COMMON DIMENSIONS	COMMON DIMENSIONS	COMMON DIMENSIONS	COMMON DIMENSIONS
	MIN	MAX	MIN	MAX
A	--	2.00	--	.079
A1	0.05	--	.002	--
A2	1.65	1.85	.065	.073
b	0.22	0.38	.009	.015
c	0.09	0.25	.0035	.010
D	SEE VARIATIONS		SEE VARIATIONS	
E	7.40	8.20	.291	.323
E1	5.00	5.60	.197	.220
e	0.65 BASIC		0.0256 BASIC	
L	0.55	0.95	.022	.037
N	SEE VARIATIONS		SEE VARIATIONS	
alpha	0°	8°	0°	8°

VARIATIONS

N	D mm.		D (inch)	
	MIN	MAX	MIN	MAX
28	9.90	10.50	.390	.413

Reference Doc.: JEDEC Publication 95, MO-150

10-0033

## Ordering Information

93716yFLF-T

Example:

XXXXX y F LF-T

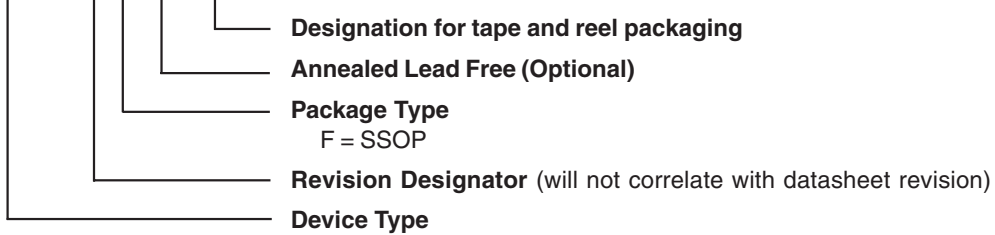

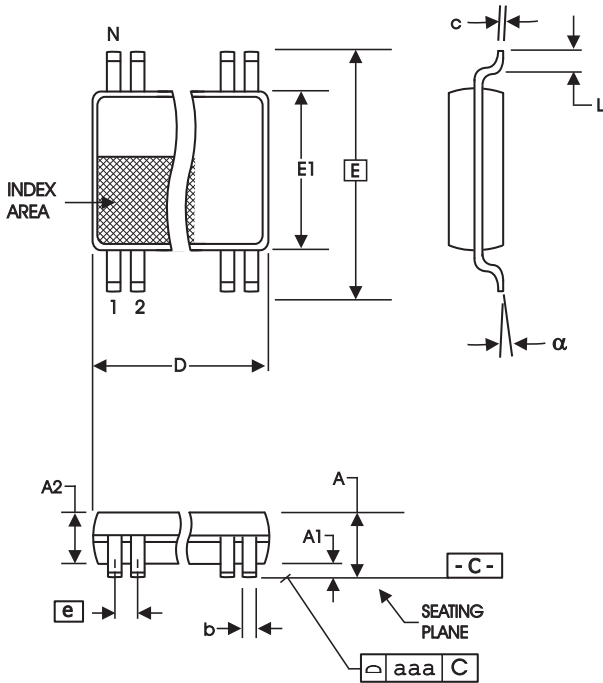

SYMBOL	In Millimeters		In Inches	
	COMMON DIMENSIONS		COMMON DIMENSIONS	
	MIN	MAX	MIN	MAX
A	--	1.20	--	.047
A1	0.05	0.15	.002	.006
A2	0.80	1.05	.032	.041
b	0.17	0.27	.007	.012
c	0.09	0.20	.0035	.008
D	SEE VARIATIONS		SEE VARIATIONS	
E	8.10 BASIC		0.319 BASIC	
E1	6.00	6.20	.236	.244
e	0.65 BASIC		0.0256 BASIC	
L	0.45	0.75	.018	.030
N	SEE VARIATIONS		SEE VARIATIONS	
$\alpha$	0°	8°	0°	8°
aaa	--	0.10	--	.004

VARIATIONS

N	D mm.		D (inch)	
	MIN	MAX	MIN	MAX
28	9.60	9.80	.378	.386

Reference Doc.: JEDEC Publication 95, MO-153

10-0039

6.10 mm. Body, 0.65 mm. pitch TSSOP  
(240 mil) (25.6 mil)

### Ordering Information

93716yGLF-T

Example:

XXXXX y GLF - T

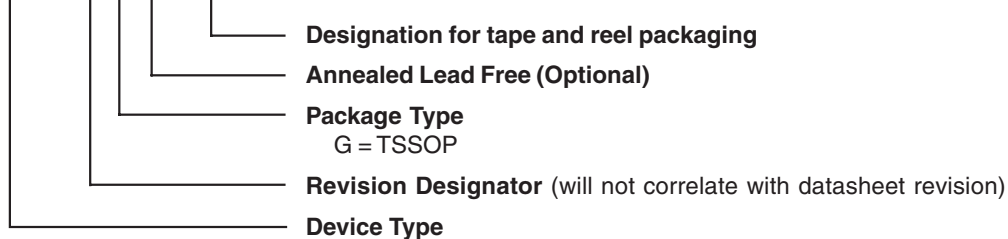

**Revision History**

<b>Rev.</b>	<b>Issue Date</b>	<b>Description</b>	<b>Page #</b>
H	9/10/2008	Updated Product Description/Features	1

## IMPORTANT NOTICE AND DISCLAIMER

RENESAS ELECTRONICS CORPORATION AND ITS SUBSIDIARIES (“RENESAS”) PROVIDES TECHNICAL SPECIFICATIONS AND RELIABILITY DATA (INCLUDING DATASHEETS), DESIGN RESOURCES (INCLUDING REFERENCE DESIGNS), APPLICATION OR OTHER DESIGN ADVICE, WEB TOOLS, SAFETY INFORMATION, AND OTHER RESOURCES “AS IS” AND WITH ALL FAULTS, AND DISCLAIMS ALL WARRANTIES, EXPRESS OR IMPLIED, INCLUDING, WITHOUT LIMITATION, ANY IMPLIED WARRANTIES OF MERCHANTABILITY, FITNESS FOR A PARTICULAR PURPOSE, OR NON-INFRINGEMENT OF THIRD-PARTY INTELLECTUAL PROPERTY RIGHTS.

These resources are intended for developers who are designing with Renesas products. You are solely responsible for (1) selecting the appropriate products for your application, (2) designing, validating, and testing your application, and (3) ensuring your application meets applicable standards, and any other safety, security, or other requirements. These resources are subject to change without notice. Renesas grants you permission to use these resources only to develop an application that uses Renesas products. Other reproduction or use of these resources is strictly prohibited. No license is granted to any other Renesas intellectual property or to any third-party intellectual property. Renesas disclaims responsibility for, and you will fully indemnify Renesas and its representatives against, any claims, damages, costs, losses, or liabilities arising from your use of these resources. Renesas' products are provided only subject to Renesas' Terms and Conditions of Sale or other applicable terms agreed to in writing. No use of any Renesas resources expands or otherwise alters any applicable warranties or warranty disclaimers for these products.

(Disclaimer Rev.1.01)

### Corporate Headquarters

TOYOSU FORESIA, 3-2-24 Toyosu,  
Koto-ku, Tokyo 135-0061, Japan  
[www.renesas.com](http://www.renesas.com)

### Trademarks

Renesas and the Renesas logo are trademarks of Renesas Electronics Corporation. All trademarks and registered trademarks are the property of their respective owners.

### Contact Information

For further information on a product, technology, the most up-to-date version of a document, or your nearest sales office, please visit [www.renesas.com/contact-us/](http://www.renesas.com/contact-us/).