

RL78 MICROCONTROLLERS

Featuring snooze mode for energy-efficient applications



BIG IDEAS
FOR EVERY SPACE

RL78 – TRUE LOW POWER™ MICROCONTROLLER FAMILY

The expanding family of Renesas RL78 microcontrollers consists of both general-purpose and application-specific devices. These increasingly popular MCUs make possible ultra-low-power applications by giving system designers advanced power-saving features and high-performance operation. Because the devices offer important capabilities such as an innovative Snooze mode that allows serial communication and ADC operation while the CPU is inactive, RL78 MCUs are demonstrably superior solutions for a vast span of battery-powered applications.

Why RL78?

- Best-in-class performance for superior designs and low power
- Scalability of package, memory and peripheral features
- System cost-saving features
- Wide voltage and temperature operation
- On-chip safety features

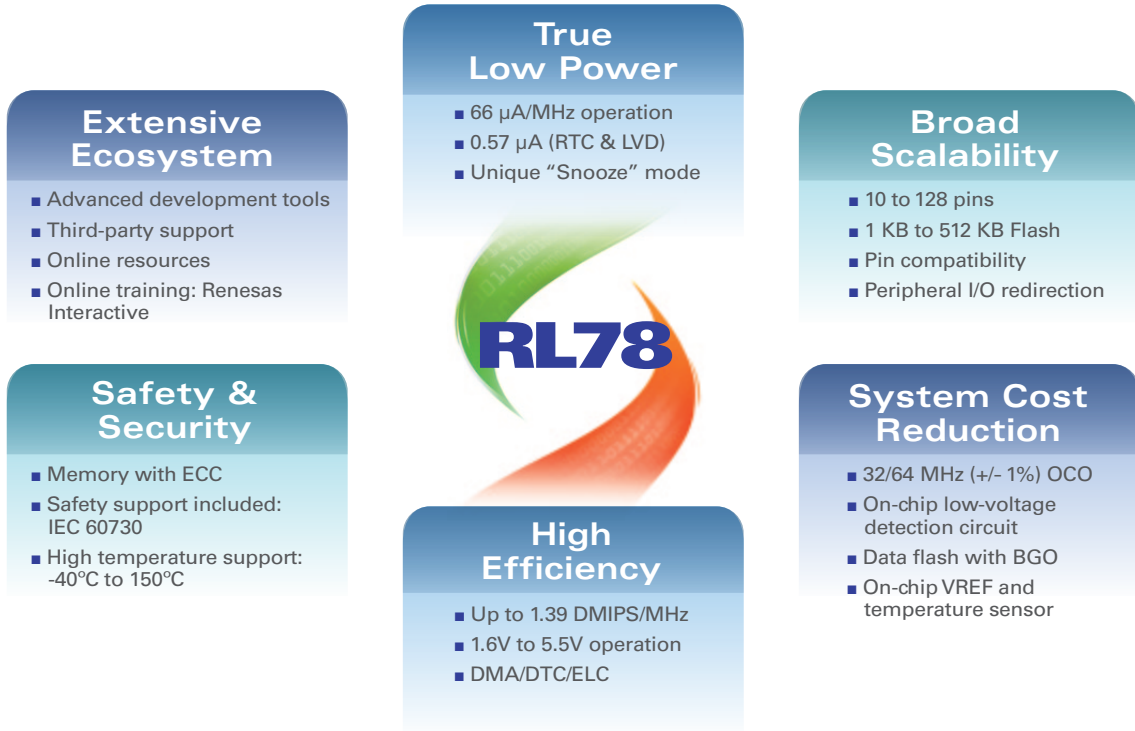

The expanding RL78 family has solutions geared to a wide variety of your design needs

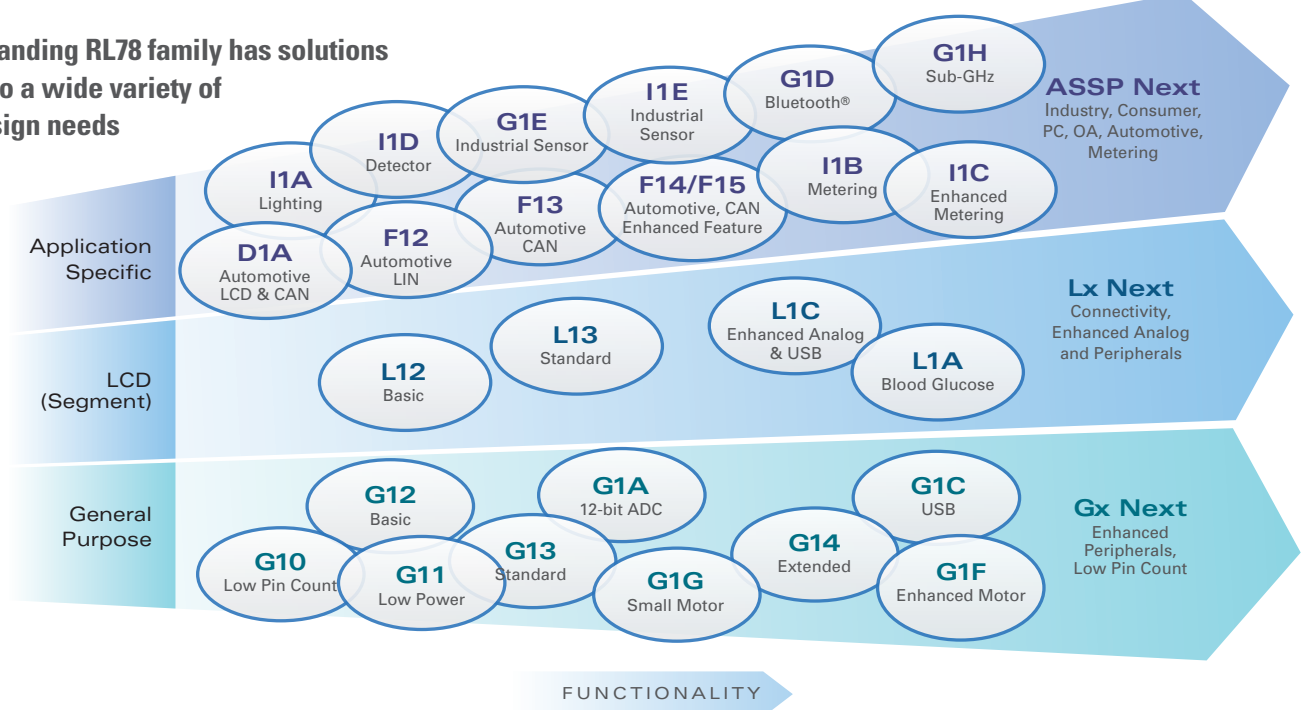

INTRODUCING THE RL78/G1F GROUP – COMPARATOR, DAC AND PGA INTEGRATION ON RL78 MCU

The RL78/G1F group is ideal for applications that require high-performance timer and analog functions in small packages, such as motor control and sensor systems, as well as various consumer and industrial applications.

RL78/G1F BLOCK DIAGRAM



VDD = 1.6 to 5.5 V
Ta = -40 to 105° C

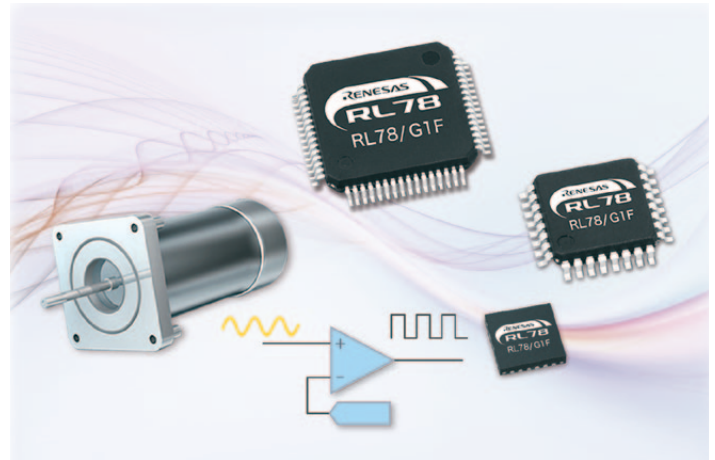
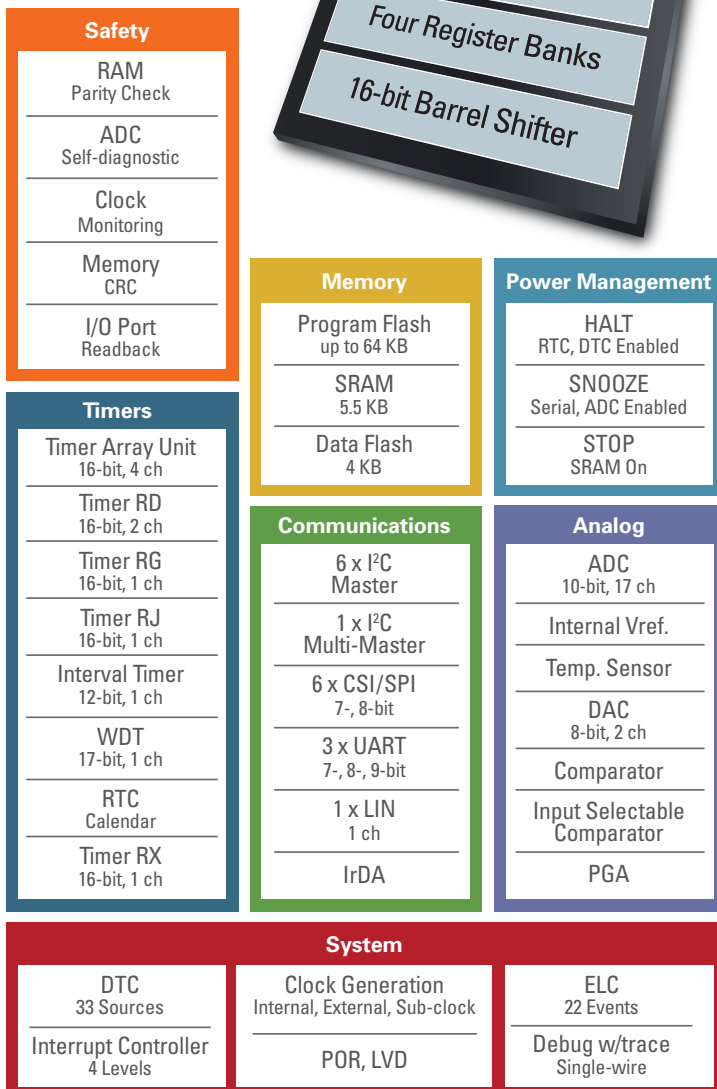
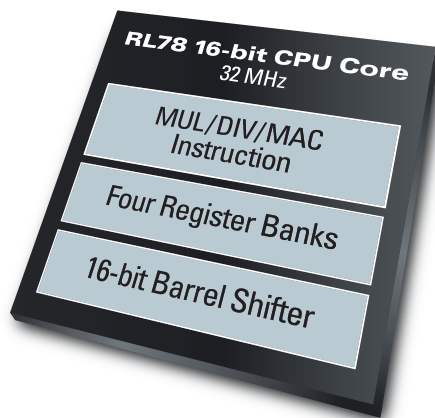

ANALOG INTEGRATIONS

- 10-bit ADC up to 17 channels with 2.125 μ s conversion time
- 8-bit DAC up to two channels
- Comparators (2 ch) with high-speed 70 ns (typ.) response time
- A comparator with two multiplexer inputs for four external inputs each
- PGA with max x32 gain and internal connection to comparator and ADC inputs

EXTENDED FEATURES

- DTC, ELC and MAC for highly efficient signal processing
- Timer RD for motor applications
- IrDA support
- RL78 common platform with 32-64 KB flash and 24-64 pins
- Migration path from R8C takes advantage of the common peripherals

Flash	64 KB	●	●	●	●	●
	32 KB	●	●	●	●	●
Package	24-pin QFN	32-pin QFP	36-pin LGA	48-pin QFP	64-pin QFP	
Size	4x4mm	7x7mm	4x4mm	7x7mm	10x10mm	
Pitch	0.5mm	0.8mm	0.5mm	0.5mm	0.5mm	
Thickness	0.8mm	1.7mm	0.76mm	1.7mm	1.7mm	
10-bit ADC	8 ch	13 ch	15 ch	17 ch	17 ch	
8-bit DAC	1 ch	2 ch	2 ch	2 ch	2 ch	
Comparator	2 ch	2 ch	2 ch	2 ch	2 ch	
PGA	1 ch	1 ch	1 ch	1 ch	1 ch	

RL78 LOW-POWER MODES MAXIMIZE BATTERY LIFE

Three low-power modes maximize battery life – either by putting on-chip functions such as the CPU, clock, and peripherals in standby – or by turning them off when they aren't being used.

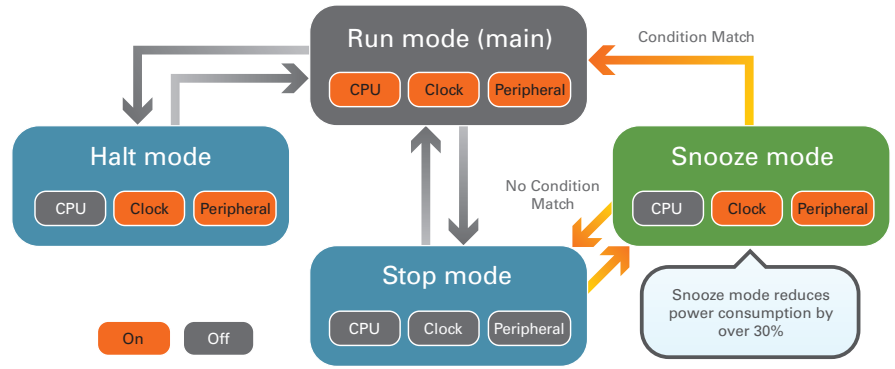

SNOOZE MODE

- Some peripherals (ADC, UART and SPI) remain operational in Standby modes.
- MCU transits from Stop mode by timer-trigger or serial-data reception.
- MCU wakes up only when acquired data matches the condition. If it does not, it goes back to Stop mode without CPU intervention.
- Power savings up to 76% can be obtained; e.g., the ADC consumes 1.2 mA in Snooze mode vs. 5.1 mA in 32 MHz Run mode.

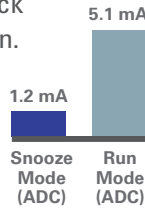

ADC CONVERSION IN SNOOZE MODE

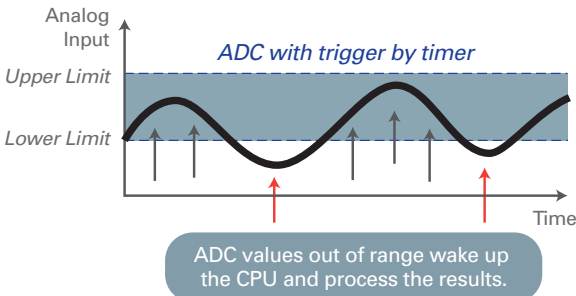

WIDE OPERATING RANGE WITHOUT SACRIFICING EFFICIENCY

- RL78 MCUs have the widest operating voltage in their class: 1.6 V to 5.5 V.
- Built-in voltage regulator allows RL78-based systems to operate from a 5.0 V with the same power consumption over the voltage range.

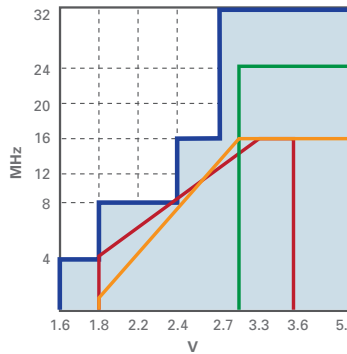

RL78/G13, G14
 A
 B
 C

HS mode: 32 MHz (max.)
2.4V-5.5V
 LS mode: 8 MHz (max.)
1.8V-5.5V
 LV mode: 4 MHz (max.)
1.6V-5.5V

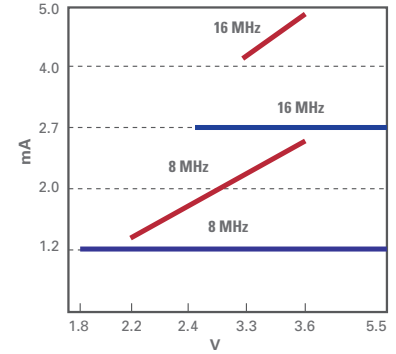

RL78/G13
 Typical MCU

RUN MODE

- In Run mode, RL78 devices offer substantial savings in current consumed when compared to competitors.

Power Consumption vs. Competition
 Current consumed ($\mu\text{A}/\text{MHz}$)

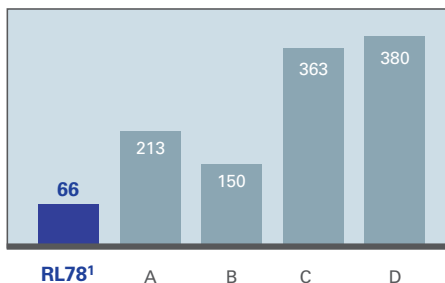

HALT MODE

- Halt mode disables CPU operation, saving as much as 80% of total MCU current, while allowing a fast CPU wake-up time.

Power Consumption vs. Competition
 Current consumed (32.768 kHz, RTC + LVD)

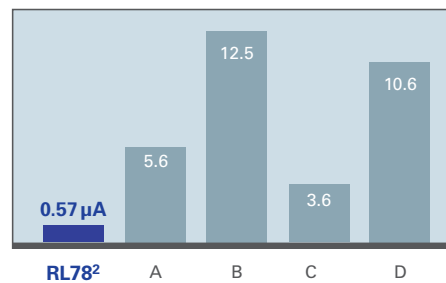

STOP MODE

- Stop mode achieves the lowest RL78 power consumption; it disables the CPU and on-chip functions that run on the CPU clock.

Power Consumption vs. Competition
 Current consumed (WDT + LVD)

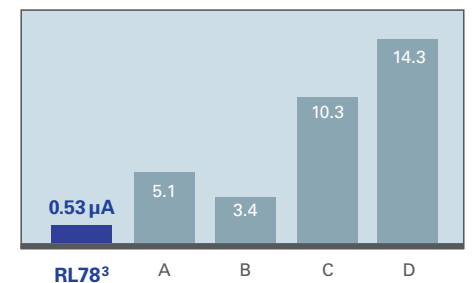

Notes: 1: At 32 MHz (NOP instructions) 2: 0.49 μA (32.786 kHz and RTC only) 3: 0.23 μA (all stopped, RAM retained)

LOW AVERAGE POWER

Multiple features of the RL78 MCUs hold average system power consumption to extremely low levels.

- Low-voltage operation (1.6 V)
- Low active current (4.6 mA @ 32 MHz)
- High efficiency (44 DMIPS @ 32 MHz)
- Low standby current with peripherals operating (0.45 μ A in Stop mode with 15 kHz clock and 12-bit interval timer running)
- CPU intervention minimization using Snooze mode (1.2 mA @ 32 MHz with ADC on)

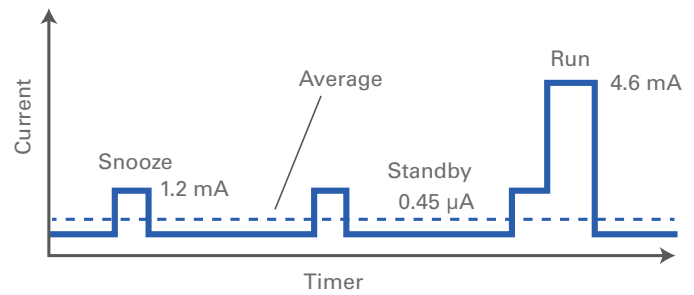

PERIPHERAL SELECTION

RL78 MCUs have versatile power-down modes and main and subsystem (32 kHz) clock options.

- Peripheral functions available in Standby mode consume miniscule current
 - 12-bit interval timer (0.02 μ A)
 - RTC (0.02 μ A)
 - WDT (0.02 μ A)
 - 15 kHz on-chip oscillator (0.20 μ A)
 - 32 kHz oscillator (0.24 μ A)
 - LVD (0.08 μ A)
- RAM data is retained in all MCU modes
- ADC, UART and SPI can be active in Snooze mode
- In Halt mode, system can wait for ADC end or serial transfer end, followed by a quick (0.3 μ s) wake-up

	Run	Halt	Snooze	Sub-Halt	Stop w/RTC	Stop
CPU	■					
Peripherals (Main system clock)	■	■	■ ADC, UART/SPI			
Peripherals (32 kHz clock)	■	■	■	■		
RTC + 32 kHz oscillator	■	■	■	■	■	
RAM retention	■	■	■	■	■	■
12-bit interval timer (Optional peripheral, 0.02 μ A)	■	■	■	■	■	■
LVD (Optional peripheral, 0.08 μ A)	■	■	■	■	■	■
WDT + 15 kHz oscillator (Optional peripheral, 0.22 μ A)	■	■	■	■	■	■
Power consumption w/o peripherals and optional peripherals unless otherwise specified	4.6 mA (32 MHz) 2.1 mA (32 MHz) ¹ 1.2 mA (8 MHz)	0.54 mA (32 MHz) 0.26 mA (8 MHz)	1.2 mA (32 MHz, ADC) 0.7 mA (32 MHz, UART/SPI)	0.49 μ A	0.49 μ A	0.23 μ A
Wake-up time ²		0.3 μ sec (32 MHz) 1.2 μ sec (8 MHz)	5 μ sec	122 μ sec	18 μ sec	18 μ sec

Notes: 1 NOP Instruction 2 Min. time All the power consumptions listed above are typical value examples of RL78/G13 (64 KB)

CLOCK CONFIGURATION

System power consumption is readily minimized by individually switching oscillators, clock lines, functions, etc., off or on as application requirements change.

- High-speed on-chip oscillator (HOCO) clock can be divided from the original source clock; its frequency can be as low as 1 MHz
- 32 kHz external clock can be used to run the CPU and peripherals
- RTC and interval timer can operate from 32 kHz or 15 kHz clocks

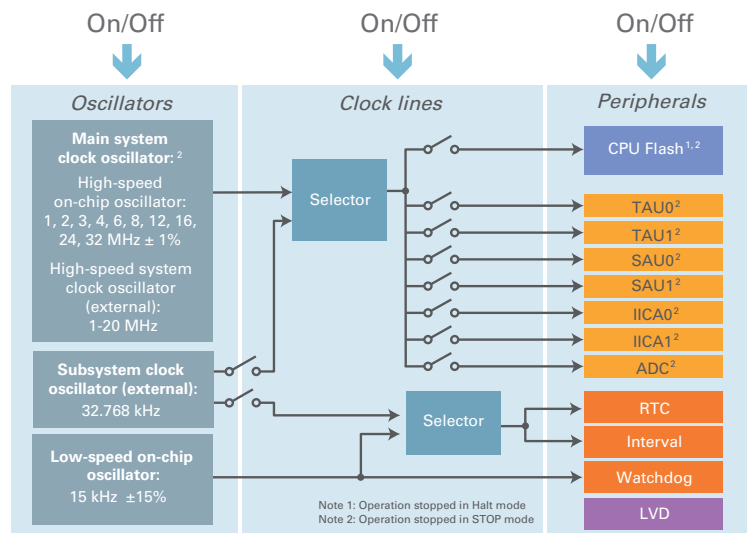

HIGH EFFICIENCY

THE RL78 FAMILY PROVIDES UP TO 44 DMIPS PERFORMANCE AT 32 MHZ

- The devices achieve an unrivaled ratio of power consumption to performance – one third of other devices, enabling significant power savings.
- RL78 devices offer important design advantages. They have a higher DMIPS rating and consume less power than popular 32-bit technology.

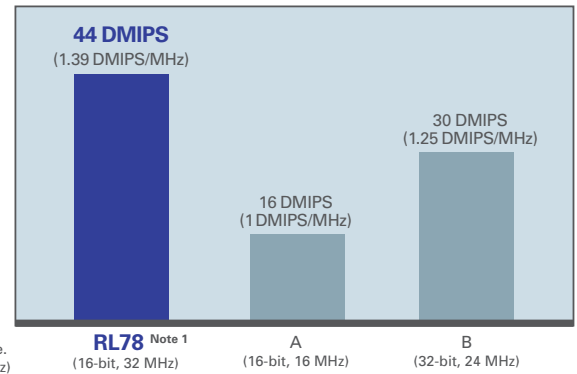

OPTIMIZED CPU ARCHITECTURE

- 16-bit CPU core incorporates a three-stage pipeline
- 86 percent of instructions execute in one or two clock cycles
- Single-cycle multiplication (hardware math assist) boosts application performance
- DMA engine has up to four channels for design flexibility

RL78 instruction execution cycles

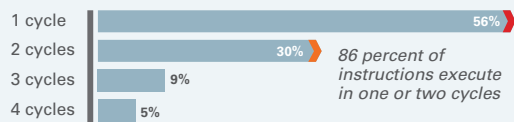

Hardware Assist for Math	Operation	Clock Cycles
16-bit Barrel Shifter for Shift and Rotate	16-bit n Shift/Rotate (n = 1 to 15)	1
Multiply Signed & Unsigned	16 x 16 = 32-bit Result	1
Multiply/Accumulate Signed & Unsigned	16 x 16 + 32 = 32-bit Result	2

EVENT LINK CONTROLLER (ELC)

- ELC routes interrupt event signals from one peripheral to another while the CPU is processing other tasks
- Reductions in interrupts improve real-time performance and reduce program size and average power consumption

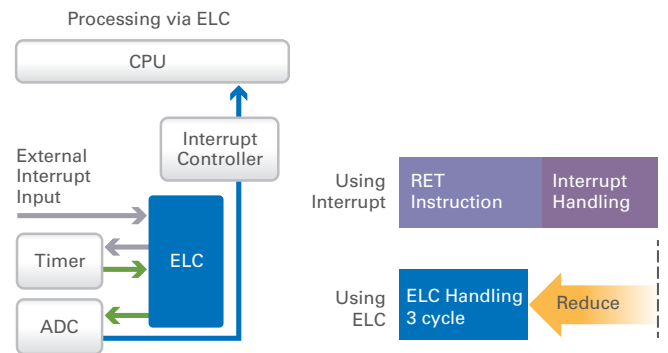

DATA TRANSFER CONTROLLER (DTC) AND DIRECT MEMORY ACCESS (DMA)

- DTC and DMA transfer data between memories without CPU intervention
- Data can be transferred faster compared to CPU processing
- DMA transfer cycle is two clocks, suitable for timing-critical tasks
- DTC is suitable for flexible data transfer for multi-purposes

	DTC (G14)	DMA (G13)
Channels, control data	24 sets	4 ch max
Activation sources	39 max	21
Transfer unit	1 or 2 bytes	1 or 2 bytes
Max block size	256 or 512 bytes	1 or 2 bytes
Max transmission time	256 times	1024 times
Source	SFR, RAM, Flash	SFR (fixed address)
Destination	SFR, RAM	RAM (incremented address)
Address	Fixed or incremented	RAM (incremented address)
Response time	3 clocks min	3 clocks min
Transfer cycles	8 clocks min	2 clocks
Transfer mode	Normal, Repeat, Chain	Single

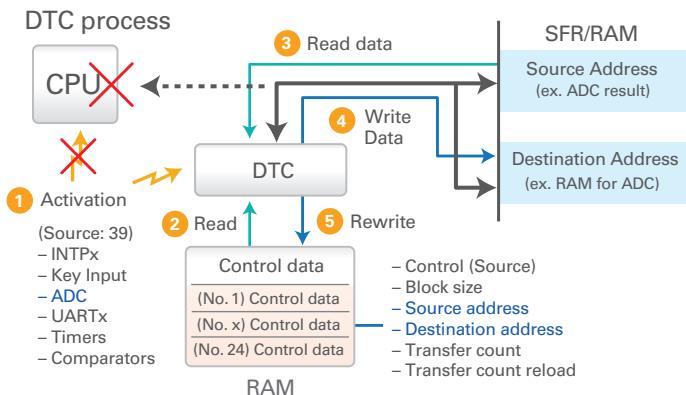

Transfer data from AD converter to RAM (Example)

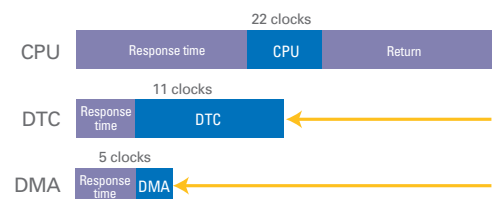

BUILT-IN FEATURES HELP REDUCE SYSTEM COST

HIGH INTEGRATION OF EXTERNAL COMPONENT FEATURES

- With many added features built in, the RL78 family can help you lower system cost and accelerate time to market

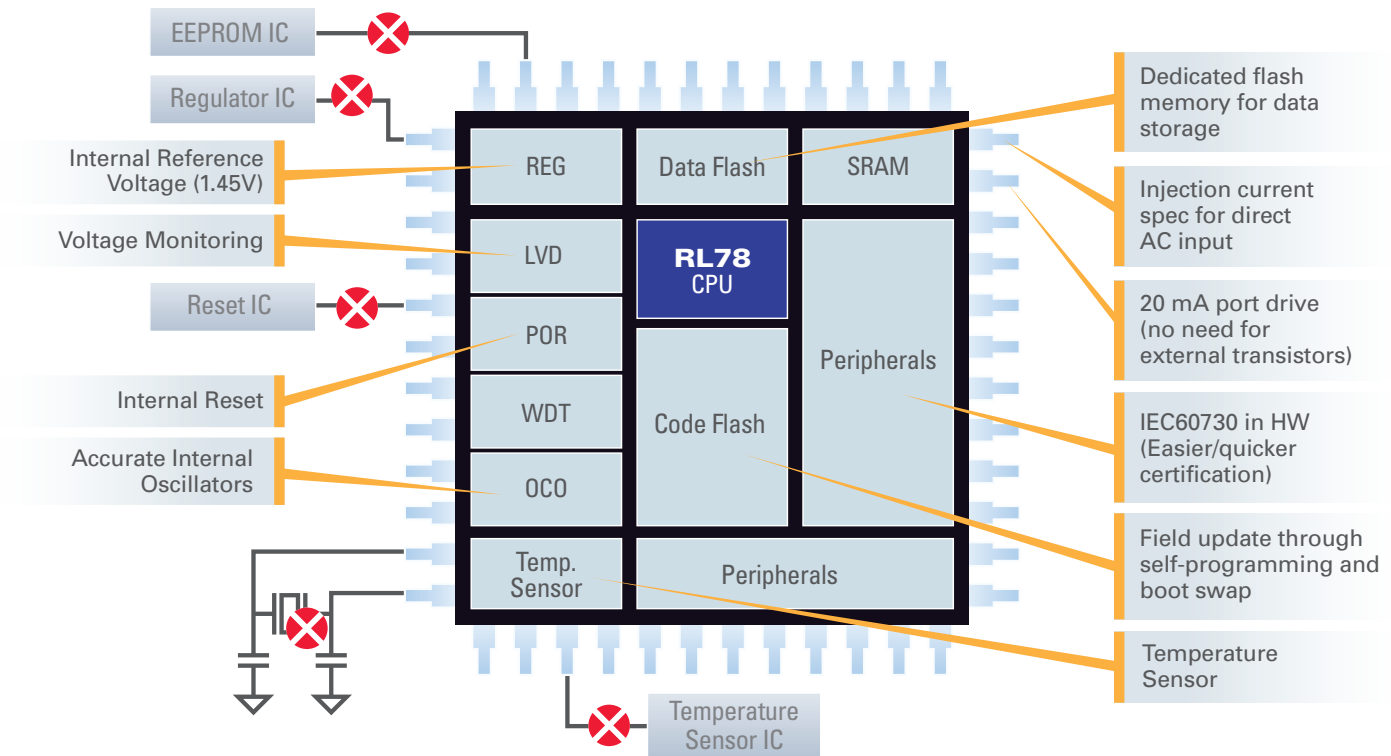

HIGH-ACCURACY, ON-CHIP OSCILLATOR

- ± 1 percent accuracy over temperature and voltage (-20 to 85°C)*
- ± 1.5 percent accuracy over temperature and voltage (-40 to 85°C)*
- Two pre-set frequencies: 24 MHz and 32 MHz
- 16/12/8/6/4/3/2/1 MHz clocks are available using a divider
- Correction register improves clock accuracy
- UART communication is implemented without factory trimming

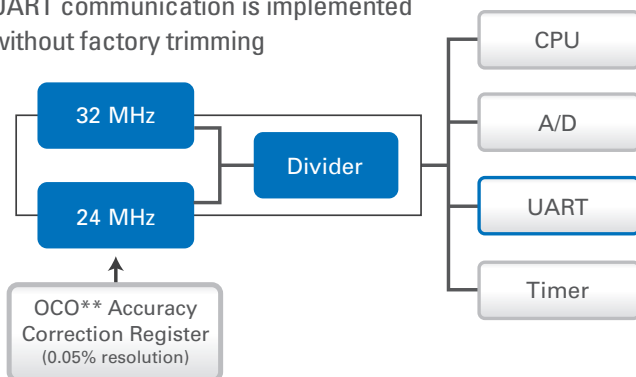

* RL78/G10: 2% (-20 to 85°C), 3% (-40 to 85°C)
 RL78/G1G: 2% (-40 to 85°C)
 ** On-chip oscillator

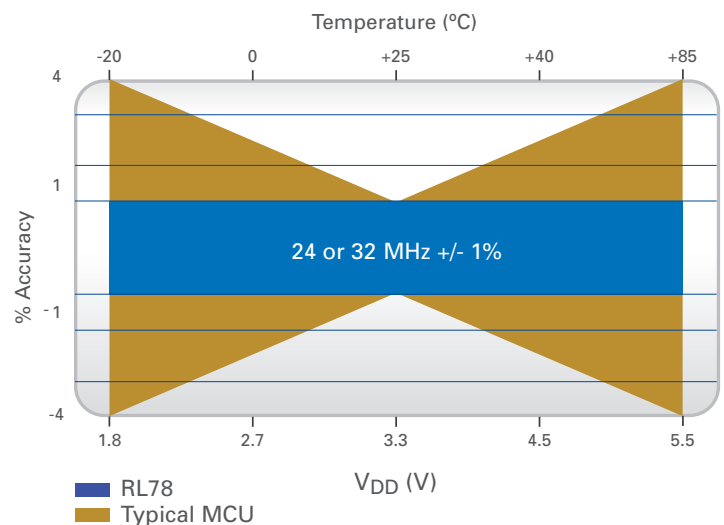

BROAD SCALABILITY

RL78 MCU SERIES PORTFOLIO

The growing RL78 family now contains 26 product groups and over 500 MCUs. Devices provide 1 KB to 512 KB of on-chip flash memory and are produced in 33 package options from 10 to 128 pins. These low-power MCUs are excellent solutions for a wide range of low-power and battery-operated products and systems used in global consumer, industrial, and automotive markets.

Application Specific

G1D
Bluetooth

G1E
Ind. Sensor

I1B
Metering

I1C
Enhanced Metering

General Purpose

G10
Low Pin Count

G11
Low Power Analog

G1A
12-bit ADC

G1C
USB

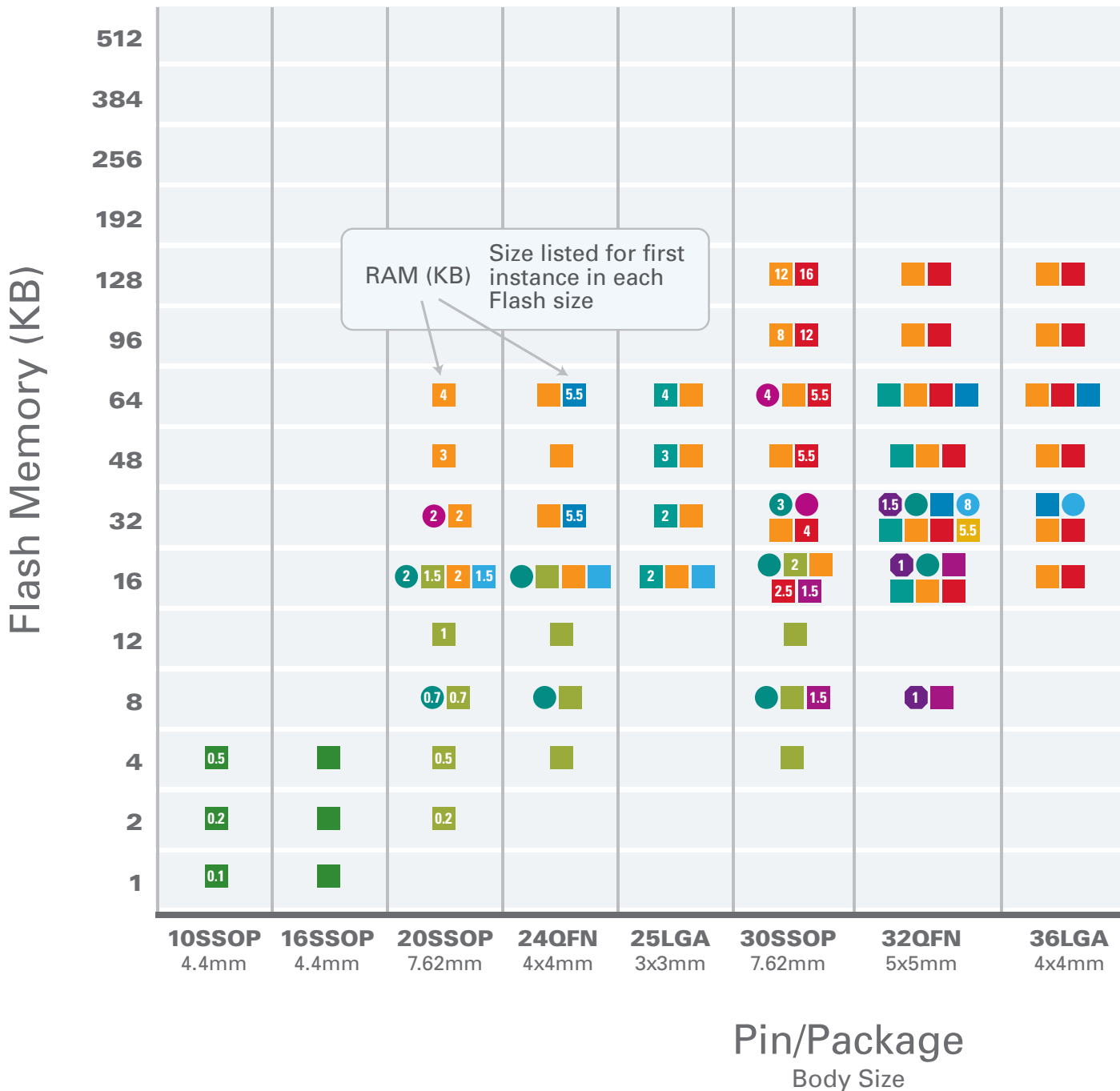

G1H
Sub-GHz

I1A
Lighting

*LCD
(Segment)*

L12
LCD Basic

L13
LCD Standard

I1D
Detector

I1E
Ind. Sensor

L1A
Blood
Glucose

L1C
LCD Extended

G12
Basic

G13
Standard

G14
Extended

G1F
Enhanced
Motor

G1G
Small Motor

	32	48					
	24	32					
	20 24	20		48	16 16		
16 20		16			16		
		12		32 8 8	12 8	5.5	
				6	10 5.5		
				24 4 4 6	8 6 5.5		
				2 3	5.5		
				1.5 2			
				1			

40QFN 6x6mm **44QFP** 10x10mm **48QFP** 7x7mm **52QFP** 10x10mm **64QFP** 10x10mm **80QFP** 12x12mm **100QFP** 14x14mm **128QFP** 14x20mm

Note: Some package options are not shown. F12, F13, F14, F15 and D1A series are not shown.

RL78 FAMILY OVERVIEW

	G10	G11	G12	G13	G14	G1A	G1C	G1D	G1E	G1F	G1G	G1H	L12	L13	L1A	L1C	I1A	I1B	I1C	I1D	I1E	F12	F13	F14	F15
Key Feature, Application	Low Pin	Low-Power Analog	Basic	Standard	Enhanced	12-bit AD	USB	Bluetooth	Ind. Sensor	Enhanced Motor	Small Motor	Sub-GHz	LCD Basic	LCD Standard	Blood Glucose	LCD Enhanced	Lighting	Metering	Enhanced Metering	Detector	Ind. Sensor	Auto	CAN Auto	CAN Auto	CAN Auto
Max speed (MHz)	20	24	24	32	32	32	24	32	32	32	24	32	24	24	24	24	32	24	32	24	32	32	32	32	32
Voltage (V)	2.0-5.5	1.6-5.5	1.8-5.5	1.6-5.5	1.6-5.5	1.6-3.6	2.4-5.5	1.6-3.6	1.6-5.5	1.6-5.5	2.7-5.5	1.8-3.6	1.6-5.5	1.6-5.5	1.8-3.6	1.6-3.6	2.7-5.5	1.9-5.5	1.7-5.5	1.6-3.6	2.4-5.5	1.8-5.5	2.7-5.5	2.7-5.5	2.7-5.5
Pin	10-16	20-25	20-30	20-128	30-100	25-64	32-48	48	64-80	24-64	30-44	64	32-64	64-80	80-100	80-100	20-38	80-100	64-100	20-48	32-36	20-64	20-80	30-100	48-144
Flash (KB)	1-4	16	2-16	16-512	16-512	16-64	32	128-256	32-64	32-64	8-16	256-512	8-32	16-128	48-128	64-256	32-64	64-128	64-256	8-32	32	8-64	16-128	48-256	128-512
Data Flash (KB)	–	2	-/2	-/4-8	4-8	4	2	8	4	4	–	8	2	4	8	8	4	–	4	2	4	4	4	4-8	8-16
RAM (KB)	0.1-0.5	1.5	0.2-2	2-32	2.5-48	2-4	5.5	12-20	2-4	5.5	1.5	24-48	1-1.5	1-8	5.5	8-16	2-4	6-8	6-16	0.7-3	8	0.5-4	1-8	4-20	10-32
Max temp. option (°C)	85	85, 105	85, 105	85, 105	85, 105	85, 105	85, 105	85	85	85, 105	85	85	85, 105	85, 105	85	85, 105	105, 125	85	85	105	105, 125	85, 125	105, 125, 150	105, 125, 150	105, 125
ADC, TAU, 12-bit interval timer, SPI, UART, I2C	■ (1)	■	■	■	■	■	■	■	■	■	■	■	■	■	■	■	■	■	■	■	■	■	■	■	■
Vref/ temp. sensor	■ (1)	■ 1.8V	■	■	■	■	■	■	■	■	■	■	■	■	■	■	■	■	■	■	■ 1.8V	■	■	■	■
Fast Wake-up 4µs max 8/16-bit interval timer		■																	■	■					
RTC (32 kHz)				■ 40pin+	■ 40pin+	■ 48pin+	■ 48pin	■	■	■ 36pin+	■	■	■ 44pin+	■	■	■	■ 38pin	■	■	■ 30pin+	■	■ 48pin+	■ 48pin+	■ 48pin+	■
MAC/DIV/MUL		■ Inst.	■	■	■ Inst.	■	■	■	■	■ Inst.	■ Inst.	■ Inst.	■	■	■ Inst.	■ Inst.	■	■ Inst.	■ Inst.	■ Inst.	■ Inst.	■	■ Inst.	■ Inst.	■ Inst.
DMA/DTC (DMA unless otherwise noted)		■ DTC	■	■	■ DTC	■	■	■	■	■ DTC	■	■ DTC	■	■	■ DTC	■ DTC	■	■ DTC	■ DTC	■ DTC	■ DTC	■	■ DTC	■ DTC	■ DTC
ELC				■					■	■	■				■	■			■	■	■			■	■
Comparator	■ 16 pin 1 ch (0.5µs)	■ 2 ch (1.2µs)			■ 96KB+ 2 ch (1.2µs)					■ 2 ch (70ns) 8-bit DAC	■ 2 ch (70ns) 8-bit DAC			■ 2 ch (1.2µs)	■ 1 ch (1.2µs)	■ 1-2 ch (1.2µs)	■ 4-6 ch (70ns) 8-bit DAC	■ 2 ch (1.2µs)		■ 2 ch (1.2µs)				■ 1 ch (70ns)	■ 1 ch (70ns)
DAC (8-bit) unless otherwise indicated		■ 1 ch			■ 96KB+ 1-2 ch				■ 4 ch	■ 1-2 ch					■ 12-bit 2 ch	■ 2 ch				■ 12-bit 1 ch				■ 1 ch	■ 1 ch
PGA/AMP		■ PGA 1 ch							■ PGA 2ch AMP 3ch	■ PGA 1 ch	■ PGA 1 ch				■ AMP 3 ch		■ PGA 1 ch			■ AMP 2-4 ch	■ AMP 3 ch				
12-bit ADC					■				■						■	■				■					
24-bit ADC																		■ 3-4 ch Pre-Amp	■ 3-4 ch Pre-Amp	■ Inst. Amp					
Motor (RD), Power stage (KB) control timer		■ KB			■ RD					■ RD	■ RD	■ RD		■ KB		■ KB	■ KB						■ RD	■ RD	■ RD
LCD													■	■	■	■			■	■					
USB							■									■									
CAN																							■ 1 ch option	■ 1 ch	■ 2 ch
2x I2C addresses		■		■ 80pin+	■ 80pin+																				
Radio								■ Blue-tooth				■ Sub-GHz													

Note (1): No Vref and 12-bit interval timer in 10-pin; no temp sensor.

RL78 PACKAGE OPTIONS



Pin-type: 10-LSSOP
Size: 4.4 x 3.6 mm
Pitch: 0.65 mm
Thickness: 1.45 mm
Group: G10



Pin-type: 16-SSOP
Size: 4.4 x 5 mm
Pitch: 0.65 mm
Thickness: 1.725 mm
Group: G10



Pin-type: 20-LSSOP
Size: 6.1 x 6.65 mm
Pitch: 0.65 mm
Thickness: 1.40 mm
Group: G13, F12, F13



Pin-type: 20-LSSOP
Size: 4.4 x 6.5 mm
Pitch: 0.65 mm
Thickness: 1.45 mm
Group: G11, G12, I1A, I1D



Pin-type: 24-HWQFN
Size: 4 x 4 mm
Pitch: 0.50 mm
Thickness: 0.80 mm
Group: G11, G12, G13, I1D, G1F



Pin-type: 25-WFLGA
Size: 3 x 3 mm
Pitch: 0.50 mm
Thickness: 0.76 mm
Group: G11, G13, G1A



Pin-type: 30-LSSOP
Size: 6.1 x 9.85 mm
Pitch: 0.65 mm
Thickness: 1.40 mm
Group: G12, G13, G14, G1G, I1A, I1D, F12, F13, F14



Pin-type: 32-LQFP
Size: 7 x 7 mm
Pitch: 0.80 mm
Thickness: 1.70 mm
Group: G14, G1C, G1G, L12, I1D, G1F



Pin-type: 32-HWQFN
Size: 5 x 5 mm
Pitch: 0.50 mm
Thickness: 0.80 mm
Group: G13, G14, G1A, G1C, F12



Pin-type: 32-HVQFN
Size: 5 x 5 mm
Pitch: 0.50 mm
Thickness: 0.90 mm
Group: I1D, I1E, F13, F14



Pin-type: 36-WFLGA
Size: 4 x 4 mm
Pitch: 0.50 mm
Thickness: 0.76 mm
Group: G13, G14, G1F



Pin-type: 36-TFBGA
Size: 4 x 4 mm
Pitch: 0.50 mm
Thickness: 1.10 mm
Group: I1E



Pin-type: 38-SSOP
Size: 6.1 x 12.3 mm
Pitch: 0.65 mm
Thickness: 2.00 mm
Group: I1A



Pin-type: 40-HWQFN
Size: 6 x 6 mm
Pitch: 0.50 mm
Thickness: 0.80 mm
Group: G13, G14

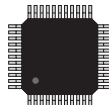

Pin-type: 44-LQFP
Size: 10 x 10 mm
Pitch: 0.80 mm
Thickness: 1.60 mm
Group: G13, G14, G1G, L12



Pin-type: 48-LFQFP
Size: 7 x 7 mm
Pitch: 0.50 mm
Thickness: 1.60 mm: G13, G14, G1A, G1C, L12, F12, F13, F14
Thickness: 1.70 mm: I1D, G1F



Pin-type: 48-HWQFN
Size: 7 x 7 mm
Pitch: 0.50 mm
Thickness: 0.80 mm
Group: G13, G14, G1A, G1C, F12



Pin-type: 48-HVQFN
Size: 7 x 7 mm
Pitch: 0.50 mm
Thickness: 0.90 mm
Group: F13, F14

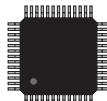

Pin-type: 48-HWQFN
Size: 6 x 6 mm
Pitch: 0.40 mm
Thickness: 0.80 mm
Group: G1D

Pin-type: 52-LQFP
Size: 10 x 10 mm
Pitch: 0.65 mm
Thickness: 1.70 mm
Group: G13, G14, L12

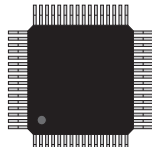

Pin-type: 64-LQFP
Size: 14 x 14 mm
Pitch: 0.80 mm
Thickness: 1.70 mm
Group: G14

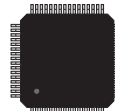

Pin-type: 64-LQFP
Size: 12 x 12 mm
Pitch: 0.65 mm
Thickness: 1.60 mm: G13, G14, L12, L13
Thickness: 1.70 mm: G13, G1A



Pin-type: 64-VFBGA
Size: 4 x 4 mm
Pitch: 0.40 mm
Thickness: 0.99 mm
Group: G13, G1A



Pin-type: 64-FLGA
Size: 5 x 5 mm
Pitch: 0.50 mm
Thickness: 0.76 mm
Group: G14

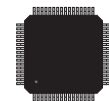

Pin-type: 64-LFQFP
Size: 10 x 10 mm
Pitch: 0.50 mm
Thickness: 1.60 mm: G13, G14¹, G1A, L12, F12, F13, F14
Thickness: 1.70 mm: L13, G1F, I1C



Pin-type: 64-HWQFN
Size: 8 x 8 mm
Pitch: 0.40 mm
Thickness: 0.80 mm
Group: L12



Pin-type: 64-HWQFN
Size: 9 x 9 mm
Pitch: 0.50 mm
Thickness: 0.80 mm: G1E
Thickness: 1.00 mm: G1H (HVQFN)

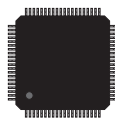

Pin-type: 80-LFQFP
Size: 12 x 12 mm
Pitch: 0.50 mm
Thickness: 1.60 mm: G13, G14¹, G1E, F13, F14
Thickness: 1.70 mm: L13, L1C, I1B, L1A, I1C

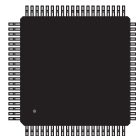

Pin-type: 80-LQFP
Size: 14 x 14 mm
Pitch: 0.65 mm
Thickness: 1.70 mm
Group: G13, G14, L13



Pin-type: 85-VFLGA
Size: 7 x 7 mm
Pitch: 0.65 mm
Thickness: 1.00 mm
Group: L1C

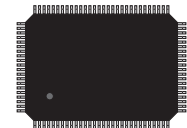

Pin-type: 100-LQFP
Size: 14 x 20 mm
Pitch: 0.65 mm
Thickness: 1.60 mm
Group: G13, G14

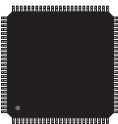

Pin-type: 100-LFQFP
Size: 14 x 14 mm
Pitch: 0.50 mm
Thickness: 1.60 mm: G13, G14¹, F14
Thickness: 1.70 mm: L1C, I1B, L1A, I1C
Group:



Pin-type: 128-LFQFP
Size: 14 x 20 mm
Pitch: 0.50 mm
Thickness: 1.60 mm
Group: G13

Symbols	Symbol Definitions
H: Heat Sink	With Heat Sink
L: Low Profile	Maximum seated height, 1.2mm < L ≤ 1.7mm
T: Thin	Maximum seated height, 1.0mm < T ≤ 1.2mm
V: Very Thin	Maximum seated height, 0.8mm < V ≤ 1.0mm
W: Very Very Thin	Maximum seated height, 0.65mm < W ≤ 0.8mm
F: Fine Pitch	Terminal pitch is 0.5mm or less. (only used for QFP) Terminal pitch is 0.8mm or less. (only used for BGA, LGA)
S: Shrink	Shrink pitch of basic package (only used for SOP, DIP, ZIP, PGA)

Note 1: G14 (384, 512 KB); Thickness is 1.70mm

COMPATIBILITY

RL78 MCU FAMILY OFFERS FULL PIN COMPATIBILITY

- I/O and peripheral pins scale up to provide design flexibility
- Additional I/O capabilities and increased functionality are easily achieved by migrating to larger pin counts
- Peripheral-pin PCB layouts can maintain the same order/position as pin counts increase
- Software code can be reused across the full RL78 family, from 10-pin to 128-pin devices

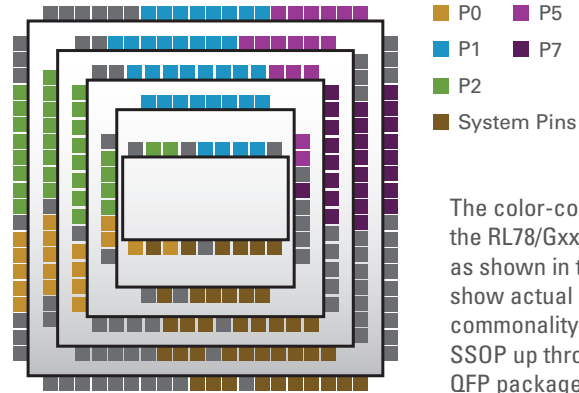

The color-coded pins of the RL78/Gxx Series, as shown in the example, show actual I/O port commonality from a 20-pin SSOP up through an 80-pin QFP package version.

FLEXIBILITY

PERIPHERAL I/O REDIRECTION (PIOR) CAPABILITY REMAPS FUNCTIONS TO ALTERNATE PORTS

- The RL78 PIOR capability solves conflicts for peripheral I/O pin assignments caused by layout or peripheral pin-sharing constraints
- Peripheral pin functionality is readily optimized by easing function bottlenecks on contested pins

PIOR capability can help ease a bottleneck, as shown in this example, by remapping to alternate pins

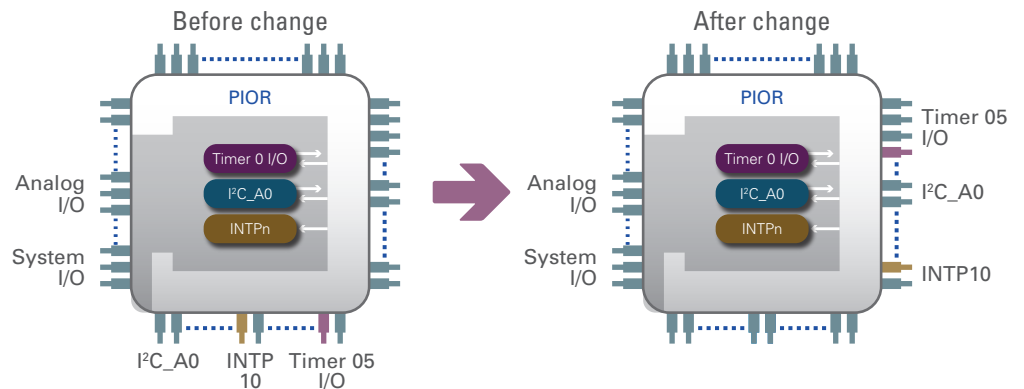

TAU & SAU FLEXIBILITY FOR ENTIRE RL78 FAMILY – CONFIGURABLE RL78 ARCHITECTURE DESIGN DELIVERS FLEXIBLE TIMER AND SERIAL COMMUNICATION

- The TAU has seven independent operation modes, as well as three multiple-channel configurations, for making PWM and one-shot pulse outputs
- For example, TAU 4 ch can be configured as follows:
 - 2 PWMs with different cycle times
 - 3 PWMs with the same cycle time
- SAU handles three types of serial communications. Resources required for these communication types include:
 - SPI/CSI: 1 channel
 - UART: 2 channels
 - IIC: 1 channel

Independent channel operation		Simultaneous channel operation function
– Interval timer	– Input pulse interval measurement	– One-shot pulse output
– Square wave output	– Measurement of high-/low-level width of input signal	– PWM output
– External event counter	– Delay counter	– Multiple PWM output
– Divider		

Unit	Channel	Used as CSI	Used as UART	Used as Simplified I2C
0	0	CSI00	UART0	IIC00
	1	CSI01		IIC01
	2	CSI10	UART1	IIC10
	3	CSI11		IIC11

NOISE IMMUNITY

RL78 OFFERS 5V SYSTEM OPERATION

The 5.0V operation and internal regulator system of RL78 MCUs give the devices inherently high levels of noise immunity, allowing savings in overall system costs.

- Noise immunity for: analog inputs, digital I/O, CPU, peripherals
- Low noise emission; CPU digital noise is encapsulated in a short wiring of REGC
- System designs can eliminate or minimize external noise-reduction filters

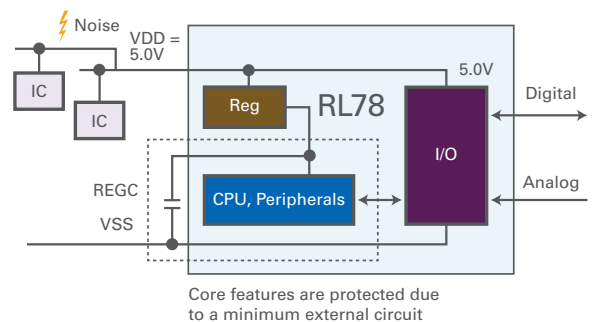

SAFETY

BUILT-IN HARDWARE FOR IEC/UL 60730 COMPLIANCE

CRC		RAM		SFR	
Memory verification		Parity/write protection		Write protection	
<ul style="list-style-type: none"> High-speed CRC: entire flash memory (64 KB/512 μs @ 32 MHz) General CRC: various data (1B/1clock) 		<ul style="list-style-type: none"> Parity: internal reset when parity error generated on Read or Write Write protection: select from 128 B / 256 B / 512 B 		<ul style="list-style-type: none"> Write protection for: port setting, interrupt setting, clock setting, LVI setting, RAM parity setting 	
CPU	CLOCK	ADC	PORT		
Illegal memory access detection	Stop detection/frequency check	AD function check	I/O function check		
<ul style="list-style-type: none"> Illegal memory access: generates "internal reset" Trap instruction: generates "internal reset" 	<ul style="list-style-type: none"> Stop detection: possible to detect by WWDT Frequency check: possible to check by timer function 	<ul style="list-style-type: none"> Self AD function check: possible by changing the inputs between external ADC input pins and external/internal AVref sources, and internal Vref and temperature sensor 	<ul style="list-style-type: none"> Read digital output level as input and verify 		

		RL78 HARDWARE/SOFTWARE RESOURCES								
		CRC	Oscillators	Window WDT	Timers	Advanced INT Controller	Output Detect Circuit	Enhanced Analog Circuits	LIN, CAN	Self-test Library
IEC 60730-1 CLASS B TEST REQUIREMENT	CPU Registers									■
	Interrupts			■	■	■				
	Clock Frequency		■		■			■		■
	ROM/Flash	■								■
	RAM	■								■
	Communication	■							■	
	I/O Peripherals				■		■			
	Analog Peripherals							■		

SECURITY

FLASH SECURITY

RL78 MCUs provide robust protection for code and data stored in flash memory in all three communication paths

ENCRYPTION/HASH LIBRARY

Renesas offers AES and SHA libraries for RL78 MCUs to facilitate the development of system security features

- OCD prohibits setting
- Authentication by OCD security ID
 - Flash memory automatically erased if ID does not match
 - Flash read out only when ID is matched

- Security settings
 - Erase protection
 - Write protection
 - Boot cluster protection
- No read command

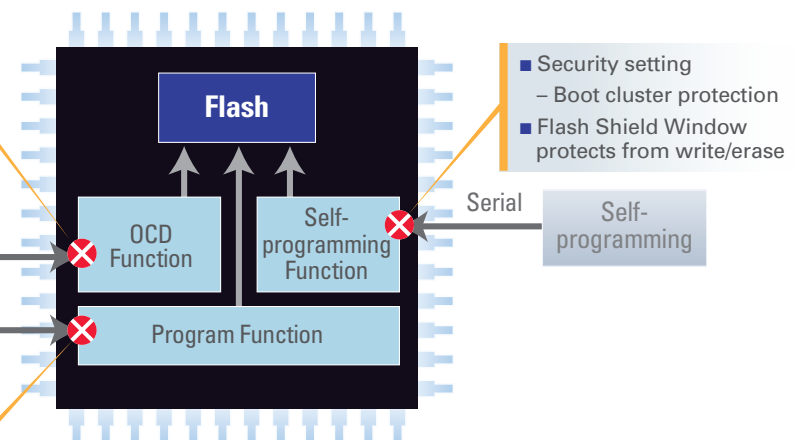

RL78/I1D AND RL78/G11 INTEGRATING NEW LOW POWER SYSTEM

LOW POWER AHEAD OF COMPETITORS

RL78 MCUs are the low-power champions in the 8/16-bit MCU market, achieving exceptional power consumption efficiency. Now, with an innovative power-saving design, the new RL78/I1D and G11 MCU Groups provide improved performance. They provide excellent task handling capabilities with miniscule current drain, exhibiting exceptional efficiency gains at clock speeds in the 1 to 4 MHz range.

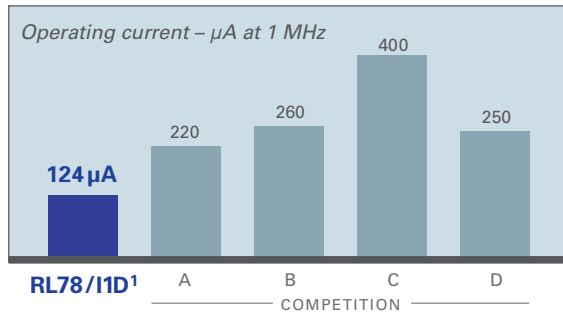

Note 1: CPU operation (Execute instruction from flash memory), Normal operation, Stop peripherals

MODE FLEXIBILITY FOR APPLICATION PERFORMANCE

Software can be used to select the best RL78/I1D and G11 speeds and operating modes (HS, LS, LV or LP) to meet variations in an application's computing requirements. A new MOCO (1/2/4 MHz) provides extra flexibility in this regard. Extraordinarily long system battery lifetimes can be achieved by taking advantage of the MCU's operating modes, available clock sources and speeds, and the run/standby/shutdown controls for on-chip functions.

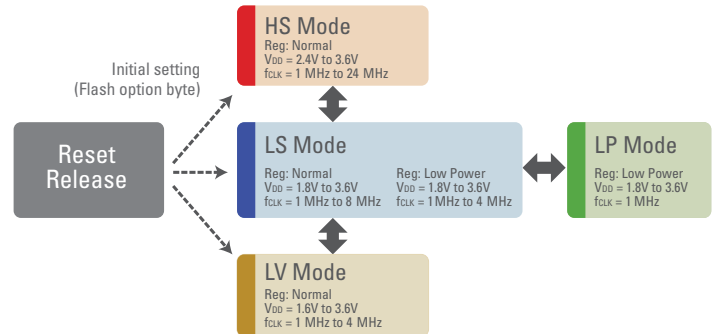

FASTER WAKE-UP MAKES FOR IMPROVED POWER CONSUMPTION

Fast wake-up times decrease system power consumption in many applications in which the MCU is inactive for extended periods, but periodically goes to Run mode to perform brief bursts of tasks. This type of operation is common in motion detectors and glass break detectors, for example. RL78/I1D and G11 MCUs have fast wake-up times and consume small amounts of current during the wake-up process. They draw less current during the Run and Halt/Snooze modes, too. In many situations, the overall current consumption of an RL78/I1D or G11 chip is much less than that of older devices such as the RL78/G13.

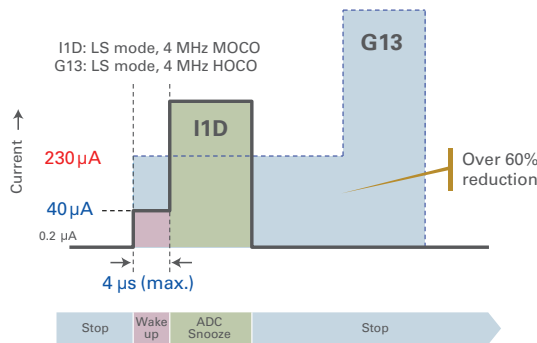

Operation Frequency	RL78/G13	RL78/I1D	Improvement
24 MHz Run	3.7 mA – 154 µA/MHz (HS mode, HOCO)	3.2 mA – 133 µA/MHz (HS mode, HOCO)	-14%
8 MHz Run	1.2 mA – 150 µA/MHz (LS mode, HOCO)	1.1 mA – 138 µA/MHz (LS mode, HOCO)	-8%
4 MHz Run	800 µA – 200 µA/MHz (LS mode, HOCO)	580 µA – 145 µA/MHz (LS mode, MOCO)	-29%
1 MHz Run	380 µA (LS mode, HOCO)	124 µA (LP mode, MOCO)	-68%
8 MHz Halt/Snooze	260 µA (LS mode, HOCO)	250 µA (LS mode, HOCO)	-4%
4 MHz Halt/Snooze	230 µA (LS mode, HOCO)	40 µA (LS mode, MOCO)	-83%
1 MHz Halt/Snooze	210 µA (LS mode, HOCO)	27 µA (LP mode, MOCO)	-87%
Stop	0.23 µA	0.22 µA	-4%

ON-CHIP VOLTAGE REFERENCE OPERATES DOWN TO 1.8V

Many embedded systems use an external regulator just to provide a stable reference voltage for the MCU's ADC. RL78/I1D and G11 MCUs have an on-chip voltage reference that eliminates the need for that external device, reducing system complexity and cost. A built-in temperature sensor is another cost-reduction feature. Additionally, inexpensive alkaline batteries can power RL78/I1D- and G11-based designs. These MCUs can use the full capacity of such batteries, obtaining maximum battery life, because they support the voltage reference, ADC, and temperature sensor functions, among others – as well as the LS, LV, and LP operating modes – at supply voltages down to 1.8V.

	RL78/G13	RL78/I1D
HS Mode	■ 2.4V ~	■ 2.4V ~
LS, LV, LP Mode	■ –	■ 1.8V ~

DTC, ELC, DOC AND SNOOZE MODE MINIMIZE THE SENSOR SYSTEM'S POWER CONSUMPTION

Operation flow example – The sensor's analog output value is captured periodically using the MCU's on-chip OpAmp and ADC.

a. 8-bit interval timer turns on the OpAmp and sensor.

b. 12-bit interval timer establishes a delay long enough for the OpAmp and sensor to stabilize.

c. 12-bit ADC measures the amplified sensor value after the stabilization time.

d. DTC saves the measured sensor value to RAM.

e. DOC judges measured result; if that result is outside the specified limits, it generates an interrupt to wake up the CPU to set an alarm, etc.

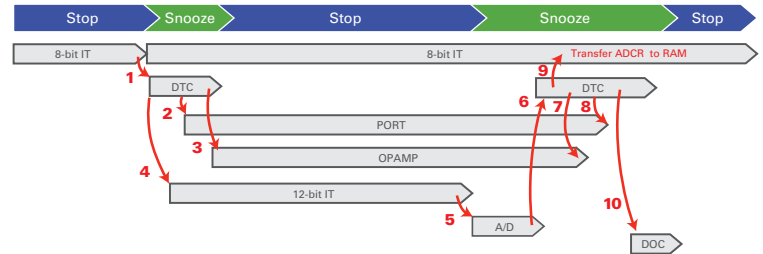
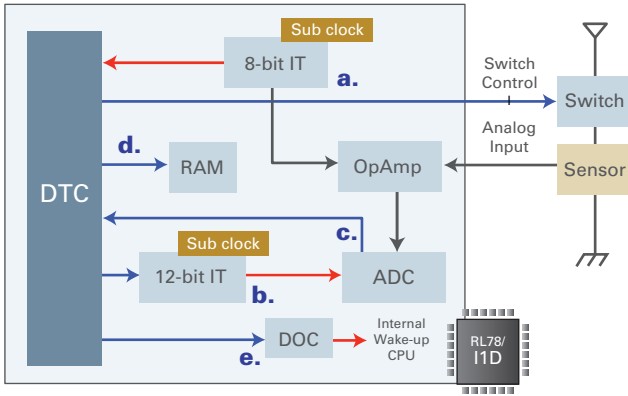

FLEXIBLE CLOCKING SOLUTIONS

The new 4 MHz MOCO is a key factor in enabling RL78/I1D- and G11-based embedded systems to deliver low-power operation and fast wake-up times. Whenever a higher-accuracy on-chip oscillator (OCO) is required (for instance, for UART communication), software can switch from the MOCO to the high-speed on-chip oscillator (HOCO), which inherently delivers ±1% accuracy over the MCU's voltage and temperature range. When the CPU executes instructions in the 15 kHz Run mode, it consumes only 1.8 μA (120 μA/MHz), allowing the use of a lower cost power regulator. Additionally, RL78/I1D MCUs with 30-, 32-, and 48-pin packages (including those in the 5x5 mm, 32-pin QFN) provide 32 kHz clock input pins for a calendar function.

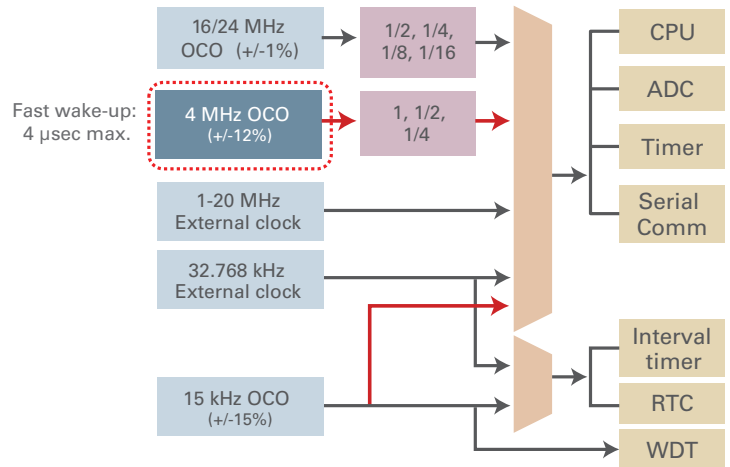

LONG INTERVAL TIMERS ARE VALUABLE IN MANY LOW POWER SYSTEMS

RL78/I1D and G11 MCUs have enhanced timing features—Four channels of 8-bit interval timers with prescalers down to 1/128. Two of the timer channels can be cascaded to operate as a 16-bit counter. That configuration generates intervals up to 9.3 minutes long and can create as many as five interrupt sources simultaneously. Each interrupt can be executed factor by factor. This simplifies software code and speeds up system operations; thus, reducing the system's overall power consumption.

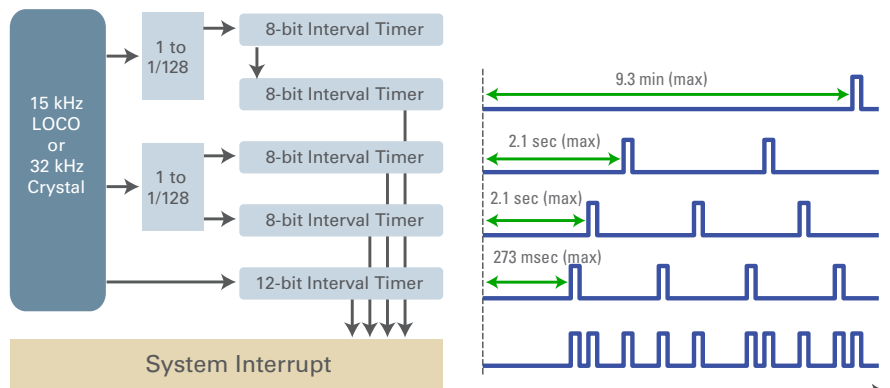

2x 8-bit IT (16-bit counter mode): 0.10 μA
 2x 8-bit IT (8-bit counter mode): 0.12 μA
 12-bit IT: 0.04 μA

VALUE PROPOSITIONS FOR VARIOUS APPLICATIONS

RL78 FOR MOTOR CONTROL

RL78/G1F, G1G AND G14 GROUPS

- RL78/G1F, G1G and G14 MCUs integrate the Timer RD motor-control timer, as well as ADC, TAU, SAU and ELC functions
- The devices can drive 5V parts without level shifters
- Compatibility is maintained for common peripherals on RL78/G1F, G1G and G14 MCUs



Power Tools

- Renesas is renowned for high-quality, long-life MCUs
- RL78 is available in multiple packages and scalable for a platform design approach



White Goods

- Integrated safety compliance (IEC 60730)
- High-temperature support
- RL78's integrated peripherals make it the ideal choice for cost-sensitive white goods



Motor Control

- RL78/G14 and G1G feature integrated motor control timers
- On-chip oscillators with 1 percent accuracy provide an integrated low-cost solution for timing-critical applications

	G1F	G1G	G14
CPU frequency (max)	32 MHz	24 MHz	32 MHz
HOCO	+/-1%	+/-2%	+/-1%
VDD	1.6V-5.5V	2.7V-5.5V	1.6V-5.5V
Motor timer	Timer RD (64 MHz)	Timer RD (48 MHz)	Timer RD (64 MHz)
Rotor feedback timer	Timer RX (64 MHz)	–	–
Comparator mask timer	TAU (1 shot)	–	–
2-phase encoder timer	Timer RG	–	Timer RG
DTC	Yes	–	Yes
Comparator	2ch 150 ns max. (8-bit DAC and 1.45V reference)	2ch 150 ns max. (8-bit DAC reference)	2ch ¹ 1.2 μs max. (0.76VDD, 0.24VDD, 1.45V reference)
PGA	1ch	1ch	–
DAC	2ch (8-bit)	–	2ch (8-bit) ¹
Pin count	24-64-pin	30-44-pin	30-100-pin
Data flash	4 KB	–	4-8 KB
Application examples	– Power tools – White goods	– Fans – Power tools	– White goods – RC motor

Note 1: 96 KB or larger flash memory size devices only

On-Chip Motor Control Features

- Three-phase (6ch) synchronous PWM output timer (Timer RD)
- Over-current protection with PGA and comparator
- Functions for controlling BEMF Brushless DC Motors

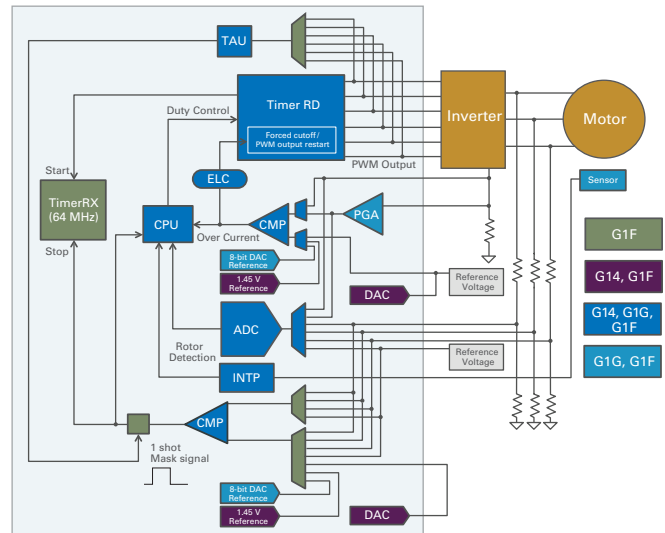

RL78/G14 Motor Control Kit

- The kit allows evaluations of motor control techniques
- Renesas offers royalty-free motor control software
- The MCUs enable field-oriented sensorless vector control
- These kits implement the 3-shunt detection approach
- RL78/G1x can greatly reduce design time and effort to meet IEC60730 compliance requirements



P/N: YRMCKITRL78G14

Application Notes for Motor Control

Type	Description	Document No.
Motor Control	V/f Control of Induction Motor (RL78/G14)	R01AN2196EJ0100
	Vector control of permanent magnetic synchronous motor using encoder	R01AN1664EJ0100
	Sensorless vector control of permanent magnetic synchronous motor	R01AN1661EJ0100
	120 degrees conducting control of permanent magnetic synchronous motor with hall sensor	R01AN1659EJ0100
	Sensorless 120 degrees conducting control of permanent magnetic synchronous motor	R01AN1660EJ0100
	Inverter control of the single-phase induction motor	R01AN1658EJ0100
	120 degrees conducting control of brushless DC motor with hall sensor	R01AN1387EJ0100
DSP	RL78 Digital Signal Controller Library – Fixed Point and Motor	R01AN1216ES0101
	RL78 Digital Signal Controller Library – Filter	R01AN1665ES0100

RL78 FOR SEGMENT DISPLAY APPLICATIONS

RL78/L12, L13 AND L1C GROUPS

The RL78/L1x Series offer an on-chip LCD drive enabling system low power and flexibility.

- Low-power LCD drive: As low as 0.68 μA , including 32 kHz and RTC currents
- More segment drive for a smaller package:
 - RL78/L1C up to 56 segments x 4 com
 - More segments using 8 com mode
- LCD booster voltage is configurable from 3.0V to 5.25V, with 0.15V resolution
- Three control methods can be used: booster, capacitor split, and resistance division
- Drive is generated for both A and B waveform panels
- Segment or I/O functions are selectable for every segment pin



Metering

- RL78 MCUs are ideal for smart metering applications with their lower power Active mode and Standby mode, including LCD and RTC current

Medical

- RL78 MCUs offer true low power consumption and their rich features are ideal for portable health and fitness devices

Home Automation

- For long battery life and operation down to 1.6V, the RL78 is the top choice

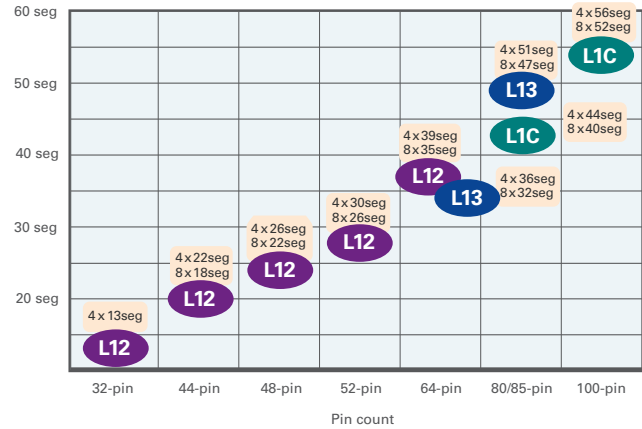
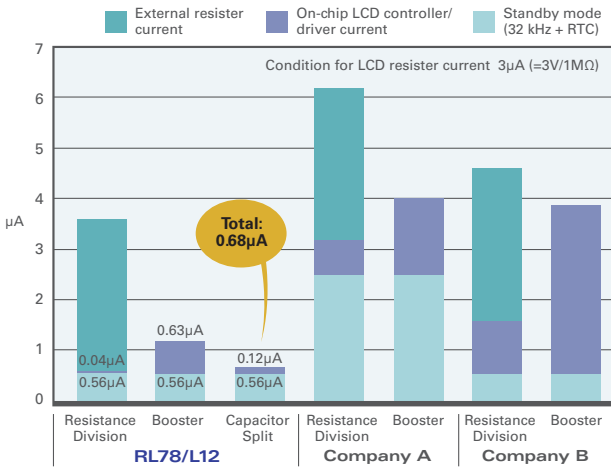

RL78/L1C Human Machine Interface (HMI) Solution Kit

Built-in segmented LCD display, software touch key, and audio playback functionality make it easy to develop and evaluate HMI for home appliances, healthcare equipment, and other products.



P/N: R0K578L1CD000B

RL78 FOR METERING

RL78/I1B AND I1C GROUPS

RL78/I1B and I1C Groups offer on-chip 24-bit $\Delta\Sigma$ -type ADC and an LCD drive capability. Their very low-power architecture and advanced analog I/O functions are optimized for high-precision sensing application with LCD display.

- Low-power features are tailored for meter requirements:
 - 3.3 mA @ 6 MHz CPU and ADC 3 ch operation
 - 0.61 μA standby with 32 kHz and RTC
 - RTC backup mode with VBAT pin
- High-accuracy clocks provide better analog accuracy and precise time data
 - 0.05% HOCO calibration by 32 kHz RTC clock
 - 0.975ppm RTC clock compensation
- The 24-bit ADC facilitates data adjustment, as does phase control and high-pass filtering by hardware

RL78/I1B	RL78/I1C
1 ph./2 wires, 1 ph./3 wires	1 ph./2 - 3 wires, 3 ph./3 wires Smart meter
64 to 128 KB 80 to 100-pin	64 to 256 KB 64, 80, 100-pin
–	AES, 32-bit MAC Battery back-up enhancement RTC separated power supply Better VREF spec.

RL78 FOR DETECTORS

RL78/I1D GROUP

Embedded systems that connect to sensors are simplified by MCUs that incorporate analog functions, which deliver quality performance, are flexible, and consume less power. RL78/I1D MCUs integrate 4-channel OpAmps (each with two inputs and one output) that can be used to implement amplifiers and filters. Their outputs can be connected directly to the MCU's built-in 12-bit ADC and comparators. That reduces pin counts, allowing smaller packages. The OpAmp and comparators have a lower power mode, so the system can be in a low-power standby mode when they are enabled. The comparators have two reference inputs; they can be configured as window comparators with upper and lower limit settings. After a comparator-driven interrupt wakes up the MCU, the analog signal from the sensor can be checked in high resolution by using the ADC and OpAmp in its high-performance operating modes.

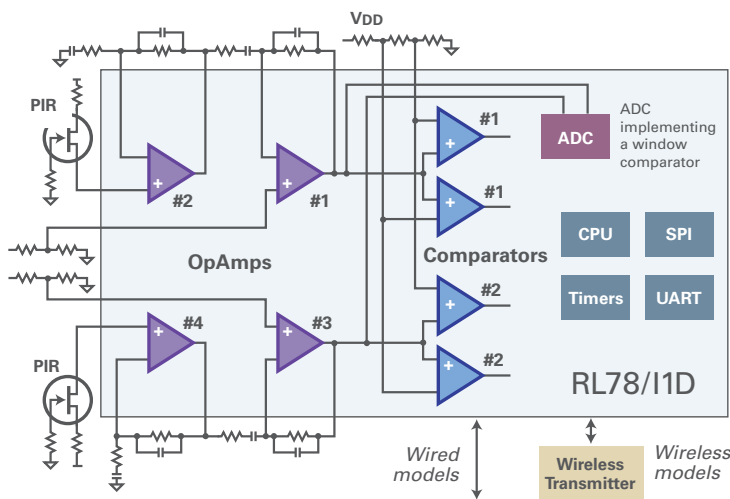

True Low Power Enhancement

- New LP mode and mid-speed on-chip oscillator (MOCO) combine to enable extremely low-power operation (124 μA at 1 MHz) with a fast wake-up capability: 4 μs (max.)
- Using the DTC, ELC, and DOC in Snooze mode implements a low-power configuration that handles tasks without CPU intervention
- New timer generates intervals up to nine minutes long using the 15 kHz low-speed on-chip oscillator (LOCO) and consumes just 0.52 μA ; up to five channels are available

Analog Integrations

- 12-bit ADC has up to 17 channels; it completes a conversion in 3.375 μs
- OpAmp (4 ch) has two modes: High Speed (1.7 MHz GBW, 140 μA) and Low Power (0.04 MHz GBW, 2.5 μA)
- Comparator (2 ch) offers a Window mode
- Internal voltage reference and temperature sensor operate down to 1.8V
- ADC and OpAmp can be started up by an ELC trigger from a timer, comparator, or external interrupt

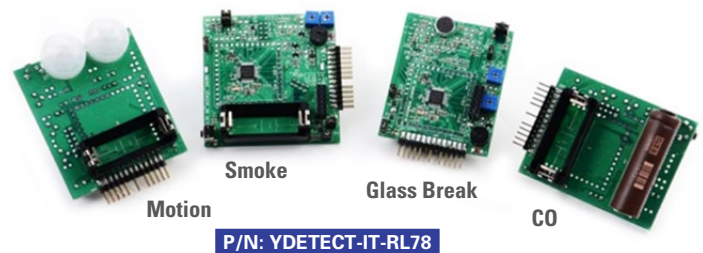

RL78 FOR BIO-SENSING

RL78/L1A GROUP

The RL78/L1A Group offers a complete set of analog front-end functions that are essential when designing bio-sensing applications such as a blood glucose meter with a low power LCD.

- Analog front end
 - 3 ch Op Amp, 12-bit ADC, 12-bit DAC and VREF
- Flexible analog configuration
 - OpAmp outputs with 4MUX for multiple sensors
 - Offset adjustment using high-resolution 12-bit DAC
- LCD
 - 32 x 4 (80-pin), 45 x 4 (100-pin)



RL78/L1A Promotion Board

P/N: YRPBRL78L1A

RL78 FOR SENSOR APPLICATIONS

RL78/I1E GROUP

The RL78/I1E MCU is an intelligent, flexible analog MCU suitable for countless industrial and medical sensing applications such as flow measurement, strain gauges, pressure, or temperature sensing. With enhanced analog features such as configurable OpAmps with programmable gain, inverted and non-inverted topology support, and instrumentation amplifiers, the RL78/I1E can be a platform for different types of sensors.

- 24-bit delta-sigma ADC, separate 10-bit ADC and 12-bit DAC
- 4x4 mm or 5x5 mm packages reduce PCB footprint
- Operating temperature up to 125°C makes it an ideal solution for the harshest of environments

Memory	Timers	Clock	Analog
Code Flash 32 KB	Timer Array Unit 16-bit, 6 ch	Main OSC 1-20 MHz	Delta-Sigma ADC with Instrumentation Amp 24-bit, 4 ch
Data Flash 4 KB	Timer RG 16-bit, 1 ch	HOCO 32 MHz / 24 MHz	SAR ADC 10-bit, 10 ch
RAM 8 KB	Timer RJ 16-bit, 1 ch	LOCO 12 kHz	OpAmp 3 ch
	Interval Timer 12-bit, 1 ch	PLL 32 MHz / 24 MHz	DAC 12-bit, 1 ch
System	Communications	I/O Port	Temp. Sensor
DTC 23 Sources	2 x CSI	CMOS In/Out 11 ch	Sensor Bias
ELC 15 Sources	2 x UART	CMOS Input 3 ch	
Interrupt Controller 4 Levels	2 x Master I2C		
POR, LVD			
On-chip Debug Single-Wire			

RL78/G1A GROUP

The RL78/G1A MCU is a G13-base device for industrial sensor applications. It offers enhanced (12-bit) ADC resolution and small package options, including a 25-pin LGA. In the 64-pin package, it provides 28 ADC input channels. Other features include:

- 12-bit ADC, 3.375 μ s, up to 28 channels
- 16 KB to 64 KB flash memory
- 25LGA, 32QFN, 48QFN, and 64BGA packages

	Resolution	Power Consumption	Conversion Time	ADC Wake-up Time	Input Range	Accuracy	Target Applications
RL78/G13	10-bit	500 μ A	2.125 μ s	1 μ s	0 to AVREFF (1.6V to 5.5V)	\pm 1.2LSB	General Purpose
RL78/G1A RL78/G1E	12-bit	420 μ A	3.375 μ s	0.5 μ s	0 to AVREFF (1.6V to 3.6V)	\pm 1.7LSB	General Purpose, Sensors
RL78/I1E	24-bit	940 μ A	64 μ s	3 ms	0.2V to 1.8V	+/- 10ppm FS INL 85dB SNDR (13.8 ENOB)	Industrial Sensor

RL78/G1E GROUP

High-accuracy sensor systems require more than just an ADC in the front end – many need an amplifier, multiplexer, filters and LDO. The MCUs in the RL78/G1E product group meet those needs. Their OpAmp buffered input channel, signal amplifier, and DAC reference are software configurable. These devices accommodate different types of sensors without sacrificing dynamic range and offset-trimming accuracy. Configurable settings for on-chip functions provide long-term calibration flexibility that can be used to compensate for degradations of sensor sensitivity over time.

- SAIC500 and RL78/G1A functions
 - SAIC500 features include a 4 ch MUX, three configurable OpAmps, gain adjustment OpAmp, DAC, LDO (variable regulator), and low- and high-pass filters
- Amplitude and offset adjustments that accommodate different types of sensors
- Compensation adjustments for sensor variations
- Long-term drift correction

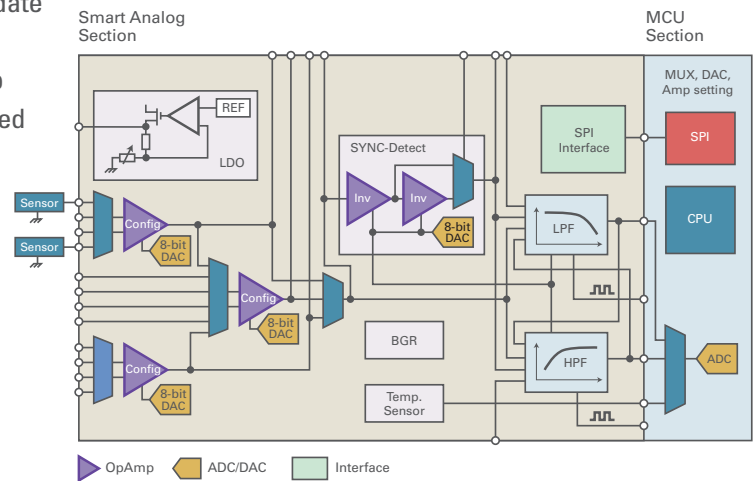

RL78/G11 GROUP

RL78/G11 Group offers a new RL78 low-power system in low pin-count packages and a small memory size, but does not compromise offering extended analog and serial functions, which accelerates efficient sensor hub applications in industrial, healthcare, and agricultural spaces.

- New low-power system
 - 4 μ s fast wake up, MOCO, 16-bit interval timer, LP Mode
- Small footprint
 - 20-, 24-, and 25-pin with 16 KB flash
- Analog
 - 10-bit ADC, 8-bit DAC, Comparators 2 ch, PGA
- Serial communications
 - 4x master I2C, 4x SPII, 2x UART, 2x I2C (master/slave) handing 2 slave addresses

RL78 FOR LIGHTING APPLICATIONS

RL78/I1A GROUP

Devices in the RL78/I1A product group offer dedicated lighting-communication features and power-stage control capabilities. They can communicate with a host controller for altering lighting intensity and/or color.

- High-resolution PWM timers enable excellent lighting control performance
- Support for the DALI/DMX512 communication standard aids system integration
- Features of the power-stage control include the 64 MHz Timer KB, which provides dithering (0.98 nsec quasi resolution), soft-start turn-on, comparator triggered stop, zero-current detection, and timer restart options
- Free Windows®-based Applilet software facilitates designs for remotely controllable lighting installations
- High-temperature support (105°C to 125°C)



Host Controller Side

Controller GUI

- DALI Master
- DMX Master



DALI/DMA512 Master Communication Board



EZ-0008

P/N: DM-78K0-LIGHTCOMM

Lighting Side

Applilet EZ for HCD



DALI/DMX512 Slave Communication Board

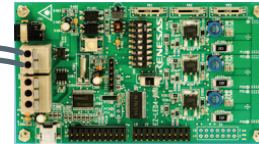

EZ-0012: RL78/I1A DC/DC LED Solution (RGB 3 LEDs on board)

P/N: Y-RL78-DCDC-LED

- Software generation (C code, Hex file)
- Programming
- Dimmer selection
 - DALI, DMX512, IR remote
 - Standalone (Fixed, Variable, ADC)
- Target boards
 - EZ-0012 and others

SUB-GHz RADIO APPLICATIONS

RL78/G1H GROUP

RL78/G1H integrates an IEEE802.15.4e/g radio that supports Wi-SUN and has the industry's leading low power consumption 6.9 mA Rx (-95 dBm) and 21 mA Tx (10 dBm).

- Sub-GHz Band: 863 MHz to 928 MHz
 - 863 to 870 MHz (Europe, India)
 - 902 to 928 MHz (US)
 - 920 to 928 MHz (Japan)
- Modulation/Data rate (kbps)
 - 2FSK/GFSK 10/20/40/50/100/150/200/300
 - 4FSK/GFSK 200/400

P/N: YTK-RLG1H+SB2

Product of Tesser Technology



CAN APPLICATIONS

RL78/F1x GROUP

MCUs in the RL78/F1x Group primarily meet the needs of networked products used in automotive markets, including aftermarket accessories. Their CAN functions and high-temperature operation also make them top choices for industrial equipment.

- Operation is supported at temperatures up to 150°C
- Devices have from 8 KB to 256 KB flash memory and from 20 to 100 pins
- Renesas automotive-grade quality reliability

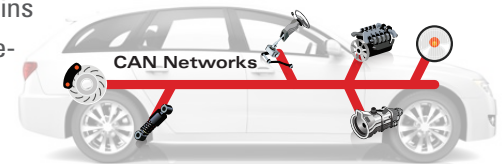

RL78 FOR USB APPLICATIONS

RL78/G1C GROUP

RL78/G1C MCUs have USB capabilities that support battery-charging specification standards. They are excellent choices for products such as intelligent USB battery/wall chargers. Their features include the following:

- USB version 2.0, host/function controller
- Full-speed (12 Mbps) and low-speed (1.5 Mbps) support
- Compliant with the 2.1A/1.0A charging mode specified in Apple MFi
- Compliant with Battery Charging Specification Revision 1.2 enabling 1.5A charging mode
- Small packages with 32 to 48 pins



USB Charger Solution Kit

P/N: R0K578G1CD010BR

RL78 FOR BLUETOOTH® APPLICATIONS

RL78/G1D GROUP

This true low power RL78 microcontroller with Bluetooth Low Energy wireless technology increases battery life and accelerates Bluetooth connected device development.

- Bluetooth Smart v4.1 connectivity supported in embedded and modem modes
- Peak Tx current of 4.3 mA and peak Rx current of 3.5 mA
- High integration minimizes BOM cost; Balun, on-chip 32 kHz oscillator
- Industry-leading support tools shorten time to market
- RF Adaptable Technology automatically optimizes power consumption versus communication range
- BT SIG qualified stack plus documented test procedure facilitate radio certification
- Firmware-over-the-air (FOTA) capability enables convenient application upgrades in the field

RF	
Bluetooth 4.1 Single Mode Master/Slave	
AES Engine	
RF Unit Power Management	
Resonator Clock 32 MHz	
Sub Clock OCO 32.768 kHz	

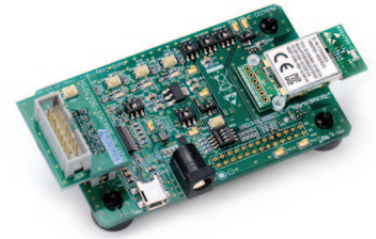

P/N: RTK0EN0001D01001BZ

Key Applications

- Home and Building Automation:** Locks, gateway, security systems
- Industrial Systems:** Asset tracking and management systems, remote displays, access control systems
- Retail Operations:** Beacons, price tags, payment systems
- Healthcare and Fitness Centers:** Blood glucose and pressure meters, weight-scales, activity monitors

Simplified RF Design

High level of integration simplifies RF design and reduces BOM count.

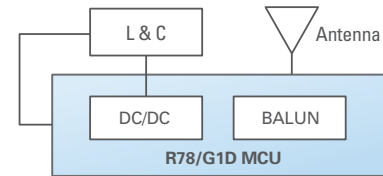

BLE Connectivity Solution

BLE Stack Configuration

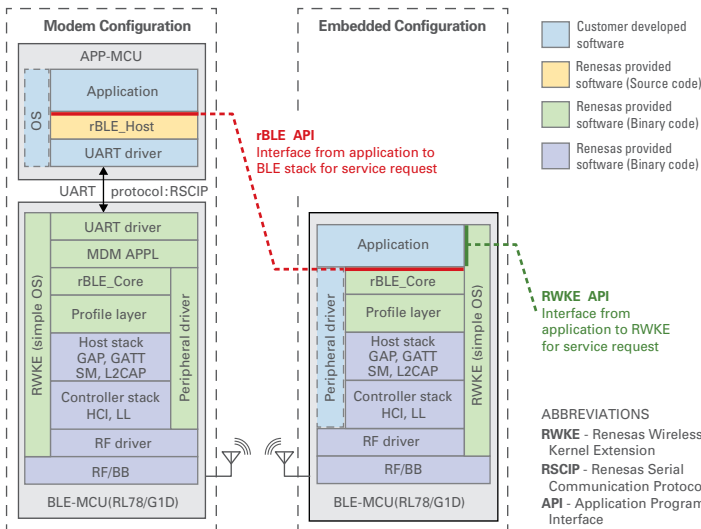

Outstanding Tx/Rx Power Efficiency



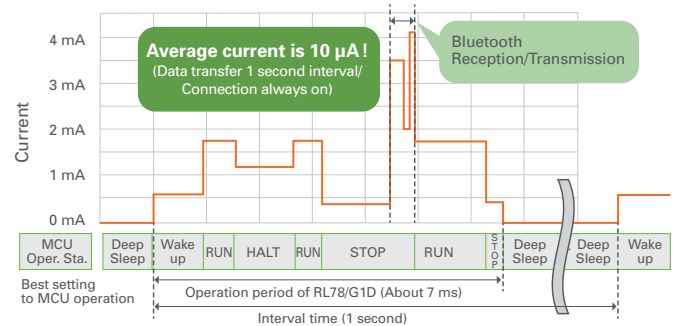

State-of-the-art radio technology enables reliable communications with low current consumption.



Easy Software Development

- Stacks**
 - Standard Protocol Stack, Beacon Stack
- Profile Configuration Tool**
 - Bluetooth Developer Studio
- G1D Solution Kit**
- Evaluation: Renesas Scanner App, PC GUI**
- AppNotes**
 - Cadence Demo with Smart Phone
 - Virtual UART
 - G14 Host, RX113 Host, Synergy S7 Host
 - Simple Connection

Accelerating Time to Market (Module Selection)

	 	 
P/N:	RY7011A0000DZ00#001 MOQ 2.5K RY7011A0000DZ00#002 MOQ 100	ISMRL78G1D-L31
RF chip:	RL78/G1D (Bluetooth low energy technology 4.1)	RL78/G1D (Bluetooth low energy technology 4.1)
Size:	8.95 x 13.35 x 1.7 mm	11 x 13 mm
Certification:	FCC (US), IC (Canada), CE (Europe), MIC (Japan)	FCC (US), CE (Europe) in process
EV-Board:	RM-110-RFB-2	ISMRL78G1D-EVB

EXTENSIVE RENESAS DEVELOPMENT ECOSYSTEM

HARDWARE TOOLS

Explore



Renesas
Promotion Board

Evaluate



Renesas
Starter Kit

Develop



Emulators
IECUBE (Full ICE) E1 (OCD)

Manufacture



Programmer
PG-FP5-EA,
Renesas Factory

RL78/G14 RPB Board
P/N: YRPBRL78G14

- RL78 high-performance demo
- Evaluate and measure the low-power modes
- PC software included (GUI, drivers)
- IAR KickStart included (16 KB code limited)
- Applilet device code generator

RL78/G14 Starter Kit
P/N: YR0K5104PS000BE

- Allows full system development
- LCD panel for diagnostic connection
- Program using E1 on-chip debugger
- C/C++ compiler included
- Trial e2 studio IDE included
- Applilet device code generator
- Sample peripheral code

E1 On-chip Debugging Emulator
P/N: R0E000010KCE00

- Universal Renesas on-chip debugger
- Debugger or flash programmer interface
- Single-wire connection to RL78 device
- Assembler and C source stepping
- Software and hardware breakpoints

IECUBE Full In-circuit Emulator
P/N: QB-RL78xxx¹

- Trace and break functions
- Time measurement
- Real-time RAM monitor function

¹: For complete part number, refer to Renesas web site.

IDE/COMPILER

IAR Embedded Workbench (EWRL78)



- Integrated development environment and optimized C++ compiler for RL78
- Full C and C++ support, MISRA C compliance checker
- Project management tools and editor
- Configuration files for all RL78 devices
- Emulator debugger support
- Run-time libraries
- Download free 16 KB code limited version at: www.iar.com/iar-embedded-workbench/renesas/rl78/

Renesas e2 studio



- Based on the popular Eclipse open-source environment
- Complete IDE supports free GNU, IAR and CC-RL compilers
- IAR & GNU build phase plug-in support, E1/IECUBE debug phase plug-in support
- Powerful project management
- Download free at: www.renesas.com/e2studio

CODE GENERATOR

Royalty-free Windows®-based code generator



- Renesas software tool generates device driver code to initialize and use on-chip peripherals
- Full code generation for IAR, GNU, CA78K0R and CC-RL compilers
- Integrated project wizard guides user to create a new project
- Download free at: www.renesas.com/applilet

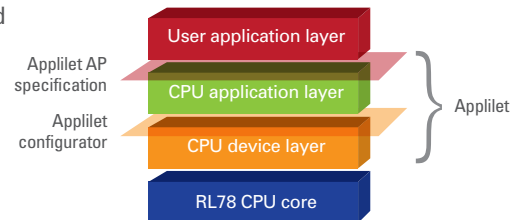

REAL-TIME OS

Micrium

μC/OS-II and μC/OS-III

- μC/OS-II™ & μC/OS-III™ RTOS
- Highly efficient and ideal for safety-critical designs



RTX

- Fast context switching time
- Nested interrupts



Free RTOS

- Free of charge RTOS for download to deploy RL78 designs
- Commercial version available as OpenRTOS



embOS

- Priority controlled RTOS based on zero interrupt latency
- Optimized for minimum memory consumption in both RAM and ROM

RL78 DEVELOPMENT HARDWARE AND SOLUTION KITS

CPU Board

- All the pins are available in 2.54 mm pitch for quick implementation to the prototype
- Easy MCU-only power evaluation by simplicity of the board
- Basic components like 32 kHz crystal; reset circuit ready
- Debugging and programming through the connector for E1 and PG-FP5

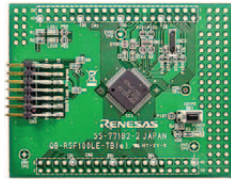

Renesas Demo Kit (RDK)

- RL78 MCU board with integrated debugger (USB powered)
- Sample projects exercising peripherals using sensors, display, audio speaker, and on-board Wi-Fi module
- IAR Embedded Workbench for RL78 (16 KB KickStart edition), including compiler and powerful debugger



RL78/xxx	CPU Board	Promotion Boards	Starter Kits	Development Kits	Solutions Kit
G10	QB-R5F10Y16-TB RTE510Y470TGB00000R	-	-	-	-
G11	YQB-R5F1057A-TB	-	-	-	-
G12	QB-R5F1026A-TB	-	-	-	-
G13	QB-R5F100LE-TB QB-R5F100SL-TB	YRPBRL78G13	YR0K50100LS000BE	YRDKRL78G13	-
G14	QB-R5F104LE-TB QB-R5F104PJ-TB FB-R5F104PL-TB ¹	YRPBRL78G14	YR0K50104PS000BE	YRDKRL78G14	YRMCKITRL78G14 (Motor control)
G1A	QB-R5F10ELE-TB	-	-	-	-
G1C	QB-R5F10JGC-TB	-	YR0K5010JGS000BE	-	R0K578G1CD010BR (USB charger)
G1D	RTK0EN001D010001BZ (Evaluation Kit)	-	-	-	YRL1D-BLE-SOL
G1D Module	RM-1110-RFB-2 ¹ (Evaluation Board)	-	-	-	-
G1E	QB-R5F10FME-TB	-	-	-	-
G1F	YQB-R5F11BLE-TB	-	-	-	RTK0EML240C03000BJ (Motor CPU Card)
G1G	YQB-R5F11EFA-TB	-	YR0K5011EFS000BE	-	-
G1H	YTK-RLG1H+SB2 ² (Evaluation Kit)	-	-	-	-
L12	QB-R5F10RLC-TB	YRPBRL78L12	YR0K5010RLS000BE	-	-
L13	QB-R5F10WVG-TB	-	YR0K5010WMS000BE	-	-
L1A	-	YRPBRL78L1A	-	-	-
L1C	QB-R5F110PJ-TB	-	YR0K50110PS000BE	-	R0K578L1CD000BR (HMI)
I1A	QB-R5F107DE-TB	-	-	-	Y-RL78-DCDC-LED (LED)
I1B	RTE510MPG0TGB00000R	-	-	-	-
I1C	-	-	-	-	-
I1D	RTE5117GC0TGB00000R	-	-	-	YDETECT-IT-RL78 (Detector)
I1E	FB-R5F11CCC-TB ¹	-	-	-	FB-R5F11CCC-LC ¹
F12	QB-R5F109GE-TB	-	-	-	-
F13	QB-R5F10BMG-TB	-	-	-	-
F14	QB-R5F10PPJ-TB	-	-	YRDKRL78F14	-
F15	-	-	-	-	-

Notes: 1) Products of Naito Densetsu Machida Mfg. 2) Product of Tesseract Technology Inc. (P/N: TK-RLG1H+SB2)

MIDDLEWARE & SOFTWARE SOLUTIONS

Category	Item	Document Number
Driver	Applilet Configurable Device Driver Generator for RL78 peripherals	-
Sample code	Sample software	-
Security	AES, GCM [RTM0RL7800SAES0UB0RR] (Contact Sales)	-
Security	SHA-1/SHA-256 Library [M3S-SHA-LIB]	R20AN0211EJ0100
Touch	Software Touch (Contact Sales)	R01AN1722EJ0100
File	Open Source FAT File System [M3S-TFAT-Tiny]	R20AN0159EJ0103
File	SPI mode MultiMediaCard Driver [M3S-TFAT-Tiny]	R20AN0158EJ0101
DSP	RL78 Digital Signal Controller Library Fixed point and Motor	R01AN1216ES0101
DSP	RL78 Digital Signal Controller Library – Filter Generic FIR, IIR Bi-quad, Single-pole IIR	R01AN1665ES0100
DSP	FFT Library Introduction Guide [M3S-FFT-LIB] 16-bit fixed-point real FFT (64, 128, 256 points)	R20AN0150EJ0101
Sound	ADPCM Encoder/Decoder [M3S-S2-Tiny]	R20AN0122EJ0101

PART NUMBER GUIDE

Example shown here: RL78/G13 (20-pin), Part number R5F1006EASP#V0

R5 F 10 0 6 E A SP #V 0

Product Group

Product Group	MCU	Flash	ROM	Series	Other
100	G13	Data Flash	10M	I1B	
101	G13	No Data Flash	10N	I1C	
102	G12	Data Flash	10P	F14	
103	G12	No Data Flash	10R	L12	
104	G14		10W	L13	
105	G11		10Y	G10	
107	I1A		110	L1C	USB
109	F12		111	L1C	No USB
10A	F13	No CAN	113	F15	
10B	F13	CAN	117	I1D	
10C	D1A	No CAN	11A	G1D	
10D	D1A	CAN	11B	G1F	
10E	G1A		11C	I1E	
10F	G1E		11E	G1G	
10J	G1C	Host/Function	11F	G1H	
10K	G1C	Function Only	11M	L1A	

Pin Count

1	10
4	16
6	20
7	24
8	25
A	30
B	32
C	36
D	38
E	40
F	44
G	48
J	52
L	64
M	80
N	85
P	100
S	128

ROM Size (KB)

4	1
6	2
7	4
8	8
9	12
A	16
C	32
D	48
E	64
F	96
G	128
H	192
J	256
K	384
L	512

Production Level

Jx	WS (Working Sample)
Kx	ES (Engineering Sample)
Bx	CS (Commercial Sample)
0,5	MP (Mass Production)

Packaging, Material (Pb-free)

#Y	Tray	Pre-MP
#U, #2	Tray (HWQFN, HVQFN, VFBGA, WLFGA, VFBGA)	
#V, #3	Tray (LFQFP, LQFP, LSSOP, SSOP)	
#W, #4	T&R (HWQFN, HVQFN, VFBGA, WLFGA, VFBGA)	
#X, #5	T&R (LFQFP, LQFP, LSSOP, SSOP)	

Package, Pin Pitch

SP	SSOP 0.65 mm	BG	VFBGA 0.4 mm
	LSSOP 0.65 mm	FA	LQFP 0.65 mm
NA	HWQFN 0.5 mm	FB	LFQFP 0.5 mm
	HVQFN 0.5 mm	FP	LQFP 0.8 mm
NB	HWQFN 0.4 mm		
LA	WLFGA 0.5 mm		
	VFLGA 0.65 mm		

Temperature & Quality Grade

A	-40° C to +85° C	Consumer
D	-40° C to +85° C	Industrial
G	-40° C to +105° C	Industrial
M	-40° C to +125° C	Industrial
J	-40° C to +85° C	Automotive
L	-40° C to +105° C	Automotive
K	-40° C to +125° C	Automotive
Y	-40° C to +150° C	Automotive

THE RENESAS ECOSYSTEM



> The Alliance Partner Program allows you to connect instantly with hundreds of qualified design consulting and contracting professionals.

www.Renesas.com/Alliance



> Gain the technical knowledge you need. Evaluate, research and learn at your own pace, where you want, when you want, for free.

www.RenesasInteractive.com

RenesasRulz.com

Think it. Build it. Post it.

> A forum and community site to share technical information, questions and opinions with others who use Renesas MCUs and MPUs.

www.RenesasRulz.com



> For educators and students. Teach with professional grade tools. Learn about MCUs with a modern architecture.

www.Renesas.com/University

MyRenesas

> Customize your data retrieval needs on the Renesas website. You'll receive updates on the products you're interested in.

www.Renesas.com/MyRenesas

Software Library – Free SW

www.Renesas.com/softwarelibrary

Free Samples

www.renassamples.com

Technical Support

www.Renesas.com/tech_support



Renesas Electronics America Inc. | renesas.com
2801 Scott Boulevard, Santa Clara, CA 95050-2554 | Phone: 1 (408) 588-6000

© 2017 Renesas Electronics America Inc. (REA). All rights reserved. The *Bluetooth*® word mark and logos are registered trademarks owned by Bluetooth SIG, Inc. and any use of such marks by Renesas is under license. Other trademarks and trade names are those of their respective owners. REA believes the information herein was accurate when given but assumes no risk as to its quality or use. All information is provided as-is without warranties of any kind, whether express, implied, statutory, or arising from course of dealing, usage, or trade practice, including without limitation as to merchantability, fitness for a particular purpose, or non-infringement. REA shall not be liable for any direct, indirect, special, consequential, incidental, or other damages whatsoever, arising from use of or reliance on the information herein, even if advised of the possibility of such damages. REA reserves the right, with out notice, to discontinue products or make changes to the design or specifications of its products or other information herein. All contents are protected by U.S. and international copyright laws. Except as specifically permitted herein, no portion of this material may be reproduced in any form, or by any means, without prior written permission from Renesas Electronics America Inc. Visitors or users are not permitted to modify, distribute, publish, transmit or create derivative works of any of this material for any public or commercial purposes.

