

Description

The ICS503 is a member of the LOCO™ family, the most cost effective way to generate a high-quality, high frequency clock output from a lower frequency crystal or clock input. The name LOCO stands for Low Cost Oscillator, as it is designed to replace crystal oscillators in most electronic systems. Using Phase-Locked-Loop (PLL) techniques, the device uses a standard fundamental mode, inexpensive crystal to produce output clocks up to 160 MHz.

Stored in the chip's ROM is the ability to generate nine different multiplication factors, allowing one chip to output many common frequencies (see table on page 2).

This product is intended for clock generation. It has low output jitter (variation in the output period), but input to output skew and jitter are not defined or guaranteed. For applications which require defined input to output skew, use the ICS570B.

Features

- Packaged as 8-pin SOIC (Pb-free) or die
- IDT's lowest cost PLL clock
- Generates 16.9344 MHz for stereo codecs from the 14.31818 MHz motherboard clock.
- Can be cost effective in replacing a single surface-mount crystal
- Can be driven by other 5xx series
- Input crystal frequency of 5 - 27 MHz
- Input clock frequency of 2 - 50 MHz
- Output clock frequencies up to 160 MHz
- Low jitter - 50 ps one sigma
- Duty cycle of 45/55 up to 160 MHz
- Operating voltages of 3.0 to 5.5V
- 25 mA drive capability at TTL levels
- Advanced, low power CMOS process

Block Diagram

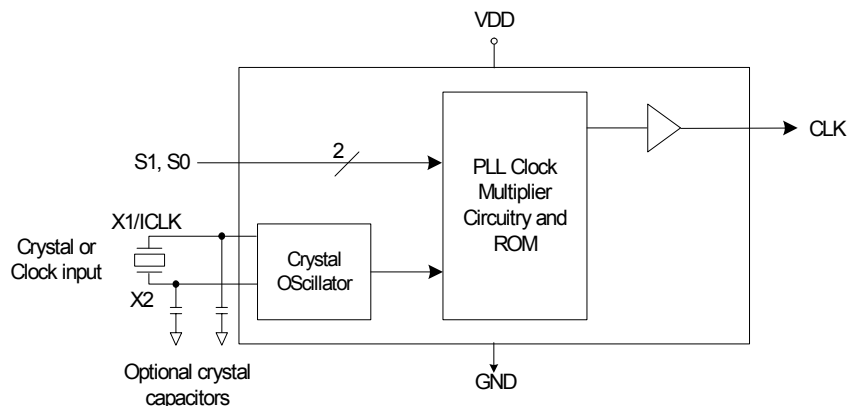

Pin Assignment

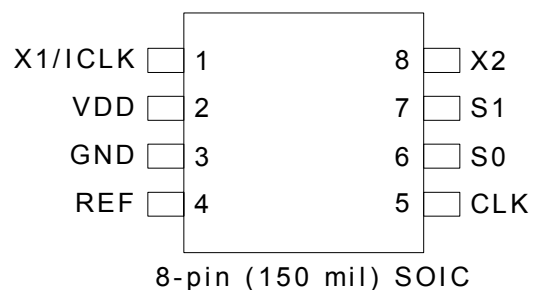

Clock Decoding Table (MHz)

S1	S0	Multiplier	Typ. Input (MHz)	CLK (MHz)	Input Range (MHz) at 5.0 V	Input Range (MHz) at 3.3 V
0	0	10	10	100	$2 \leq \text{Input} \leq 16$	$2 \leq \text{Input} \leq 16$
0	M	16	10	160	$2 \leq \text{Input} \leq 10$	$2 \leq \text{Input} \leq 6$
0	1	1.1111	27	30	$20 \leq \text{Input} \leq 50$	$20 \leq \text{Input} \leq 40$
M	0	2.4444	14.31818	35	$10 \leq \text{Input} \leq 50$	$10 \leq \text{Input} \leq 40$
M	M	2.4164	14.31818	34.60	$10 \leq \text{Input} \leq 50$	$10 \leq \text{Input} \leq 40$
M	1	2.4	14.31818	34.36	$10 \leq \text{Input} \leq 50$	$10 \leq \text{Input} \leq 40$
1	0	5.5873	14.31818	80	$14 \leq \text{Input} \leq 28$	$14 \leq \text{Input} \leq 18$
1	M	1.1827	14.31818	16.934	$14 \leq \text{Input} \leq 30$	$14 \leq \text{Input} \leq 30$
1	1	4.1905	14.31818	60	$5 \leq \text{Input} \leq 38$	$5 \leq \text{Input} \leq 24$

0 = connect directly to ground

1 = connect directly to VDD

M = leave unconnected (floating)

Pin Descriptions

Pin Number	Pin Name	Pin Type	Pin Description
1	XI/ICLK	Input	Crystal connection or clock input.
2	VDD	Power	Connect to +3.3 V or +5 V.
3	GND	Power	Connect to ground.
4	NC	—	No connect. Do not connect anything to this pin.
5	CLK	Output	Clock output per table above. Output frequency equals input frequency times multiplier.
6	S0	Tri-level Input	Select 0 for output clock. Connect to GND or VDD or float.
7	S1	Tri-level Input	Select 1 for output clock. Connect to GND or VDD or float.
8	X2	Output	Crystal connection. Leave unconnected for clock input.

External Components

Decoupling Capacitor

As with any high-performance mixed-signal IC, the ICS503 must be isolated from system power supply noise to perform optimally.

A decoupling capacitor of 0.01 μ F must be connected between VDD and GND. It must be connected close to the ICS503 to minimize lead inductance. No external power supply filtering is required for the ICS503.

Series Termination Resistor

A 33 Ω terminating resistor can be used next to the CLK pin. The total on-chip capacitance is approximately 12 pF. A parallel resonant, fundamental mode crystal should be used.

Crystal Load Capacitors

The device crystal connections should include pads for small capacitors from X1 to ground and from X2 to ground. These capacitors are used to adjust the stray capacitance of the board to match the nominally required crystal load capacitance. Because load capacitance can only be increased in this trimming process, it is important to keep stray capacitance to a minimum by using very short PCB traces (and no vias) between the crystal and device. Crystal capacitors, if needed, must be connected from each of the pins X1 and X2 to ground.

The value (in pF) of these crystal caps should equal $(C_L - 12 \text{ pF}) \times 2$. In this equation, C_L = crystal load capacitance in pF. Example: For a crystal with a 16 pF load capacitance, each crystal capacitor would be 8 pF $[(16 - 12) \times 2] = 8$.

Absolute Maximum Ratings

Stresses above the ratings listed below can cause permanent damage to the ICS503. These ratings, which are standard values for IDT commercially rated parts, are stress ratings only. Functional operation of the device at these or any other conditions above those indicated in the operational sections of the specifications is not implied. Exposure to absolute maximum rating conditions for extended periods can affect product reliability. Electrical parameters are guaranteed only over the recommended operating temperature range.

Item	Rating
Supply Voltage, VDD	7 V
All Inputs and Outputs	-0.5 V to VDD+0.5 V
Ambient Operating Temperature	0 to +70° C
Storage Temperature	-65 to +150° C
Soldering Temperature	260° C

Recommended Operation Conditions

Parameter	Min.	Typ.	Max.	Units
Ambient Operating Temperature	0	–	+70	°C
Power Supply Voltage (measured in respect to GND)	+3		+5.5	V

DC Electrical Characteristics

VDD=5.0 V ±5% , Ambient temperature 0 to +70° C, unless stated otherwise

Parameter	Symbol	Conditions	Min.	Typ.	Max.	Units
Operating Voltage	VDD		3		5.5	V
Input High Voltage, ICLK only	V _{IH}	ICLK (pin 1)	(VDD/2)+1	VDD/2		V
Input Low Voltage, ICLK only	V _{IL}	ICLK (pin 1)		VDD/2	(VDD/2)-1	V
Input High Voltage	V _{IH}	S0, S1	VDD-0.5			V
Input Mid Voltage	V _{IM}	S1, S0		VDD/2		V
Input Low Voltage	V _{IL}	S0, S1			0.5	V
Output High Voltage, CMOS high	V _{OH}	I _{OH} = -4 mA	VDD-0.4			V
Output High Voltage, CMOS high	V _{OH}	I _{OH} = -25 mA	2.4			V
Output Low Voltage	V _{OL}	I _{OL} = 25 mA			0.4	V
IDD Operating Supply Current, 14 MHz crystal		No load, 80 MHz		16		mA
Short Circuit Current		CLK output		±70		mA
Input Capacitance, S1, S0		Pins 6, 7		4		pF

AC Electrical Characteristics

VDD = 5.0V ±5%, Ambient Temperature 0 to +70° C, unless stated otherwise

Parameter	Symbol	Conditions	Min.	Typ.	Max.	Units
Input Frequency, crystal input	F _{IN}		5		27	MHz
Input Frequency, clock input	F _{IN}		2		50	MHz
Output Frequency, VDD = 4.5 to 5.5V	F _{OUT}		14		160	MHz
Output Frequency, VDD = 3.0 to 3.6V			14		100	MHz
Output Clock Rise Time	t _{OR}	0.8 to 2.0 V		1		ns
Output Clock Fall Time	t _{OF}	2.0 to 8.0V		1		ns
Output Clock Duty Cycle	t _{OD}	at VDD/2	45	49-51	55	%
Absolute Clock Period Jitter	t _{ja}	Deviation from mean		±100		ps
One Sigma Clock Period Jitter	t _{js}			30		ps

Package Outline and Package Dimensions (8-pin SOIC, 150 Mil. Narrow Body)

Package dimensions are kept current with JEDEC Publication No. 95

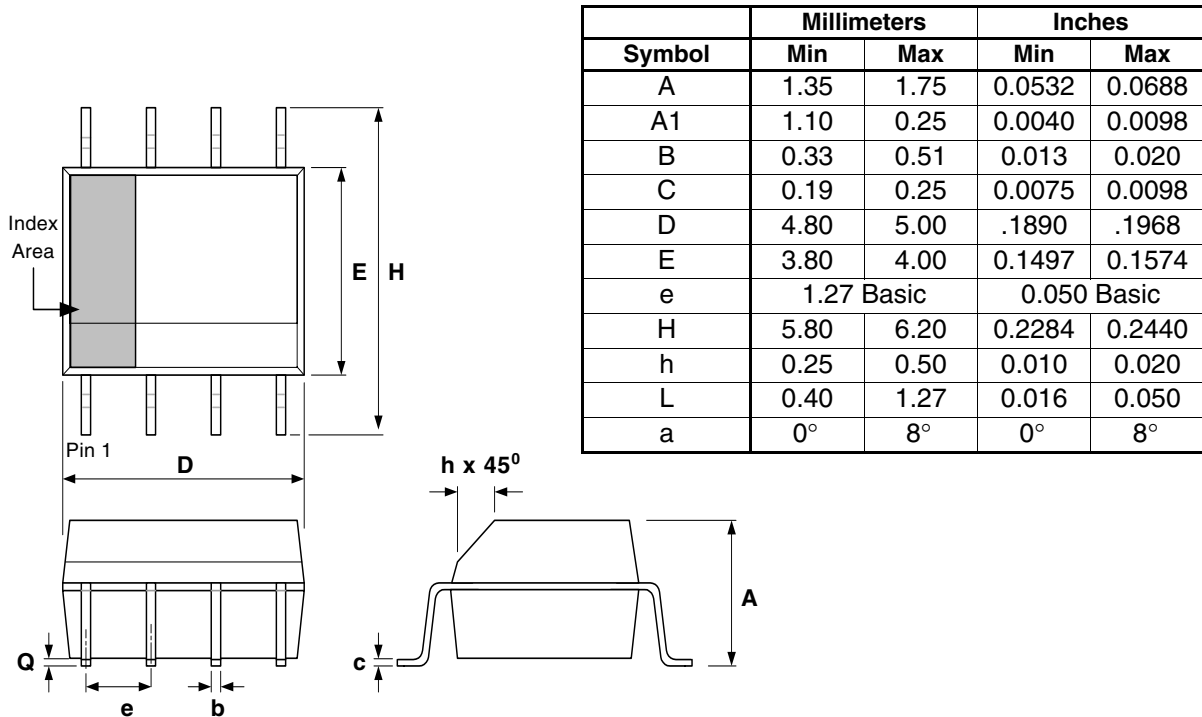

Ordering Information

Part / Order Number	Marking	Shipping packaging	Package	Temperature
503MLF	503MLF	Tubes	8 pin SOIC	0 to +70° C
503MLFT	503MLF	Tape and Reel	8 pin SOIC	0 to +70° C

“LF” denotes Pb-free packaging, RoHS compliant.

While the information presented herein has been checked for both accuracy and reliability, Integrated Device Technology (IDT) assumes no responsibility for either its use or for the infringement of any patents or other rights of third parties, which would result from its use. No other circuits, patents, or licenses are implied. This product is intended for use in normal commercial applications. Any other applications such as those requiring extended temperature range, high reliability, or other extraordinary environmental requirements are not recommended without additional processing by IDT. IDT reserves the right to change any circuitry or specifications without notice. IDT does not authorize or warrant any IDT product for use in life support devices or critical medical instruments.

IMPORTANT NOTICE AND DISCLAIMER

RENESAS ELECTRONICS CORPORATION AND ITS SUBSIDIARIES (“RENESAS”) PROVIDES TECHNICAL SPECIFICATIONS AND RELIABILITY DATA (INCLUDING DATASHEETS), DESIGN RESOURCES (INCLUDING REFERENCE DESIGNS), APPLICATION OR OTHER DESIGN ADVICE, WEB TOOLS, SAFETY INFORMATION, AND OTHER RESOURCES “AS IS” AND WITH ALL FAULTS, AND DISCLAIMS ALL WARRANTIES, EXPRESS OR IMPLIED, INCLUDING, WITHOUT LIMITATION, ANY IMPLIED WARRANTIES OF MERCHANTABILITY, FITNESS FOR A PARTICULAR PURPOSE, OR NON-INFRINGEMENT OF THIRD-PARTY INTELLECTUAL PROPERTY RIGHTS.

These resources are intended for developers who are designing with Renesas products. You are solely responsible for (1) selecting the appropriate products for your application, (2) designing, validating, and testing your application, and (3) ensuring your application meets applicable standards, and any other safety, security, or other requirements. These resources are subject to change without notice. Renesas grants you permission to use these resources only to develop an application that uses Renesas products. Other reproduction or use of these resources is strictly prohibited. No license is granted to any other Renesas intellectual property or to any third-party intellectual property. Renesas disclaims responsibility for, and you will fully indemnify Renesas and its representatives against, any claims, damages, costs, losses, or liabilities arising from your use of these resources. Renesas' products are provided only subject to Renesas' Terms and Conditions of Sale or other applicable terms agreed to in writing. No use of any Renesas resources expands or otherwise alters any applicable warranties or warranty disclaimers for these products.

(Disclaimer Rev.1.01 Jan 2024)

Corporate Headquarters

TOYOSU FORESIA, 3-2-24 Toyosu,
Koto-ku, Tokyo 135-0061, Japan
www.renesas.com

Trademarks

Renesas and the Renesas logo are trademarks of Renesas Electronics Corporation. All trademarks and registered trademarks are the property of their respective owners.

Contact Information

For further information on a product, technology, the most up-to-date version of a document, or your nearest sales office, please visit www.renesas.com/contact-us/.