

Description

The 552-02S is a low skew, single-input to eight- output clock buffer. The device offers a dual input with pin select for switching between two clock sources. It has best in class Additive Phase Jitter of sub 50fsec

IDT makes many non-PLL and PLL based low skew output devices as well as Zero Delay Buffers to synchronize clocks. Contact us for all of your clocking needs.

Features

- Low RMS Additive Phase Jitter: 50fs
- Low output skew: 50ps
- Operating Voltages of 1.8V to 3.3V
- Packaged in 16-pin TSSOP and 16-pin VFQFN, Pb-free
- Input clock multiplexer simplifies clock selection
- Output Enable pin tri-states outputs
- Input/Output clock frequency up to 200 MHz
- Low power CMOS technology
- 3.3V tolerant inputs
- Extended temperature (-40°C to +105°C)

Block Diagram

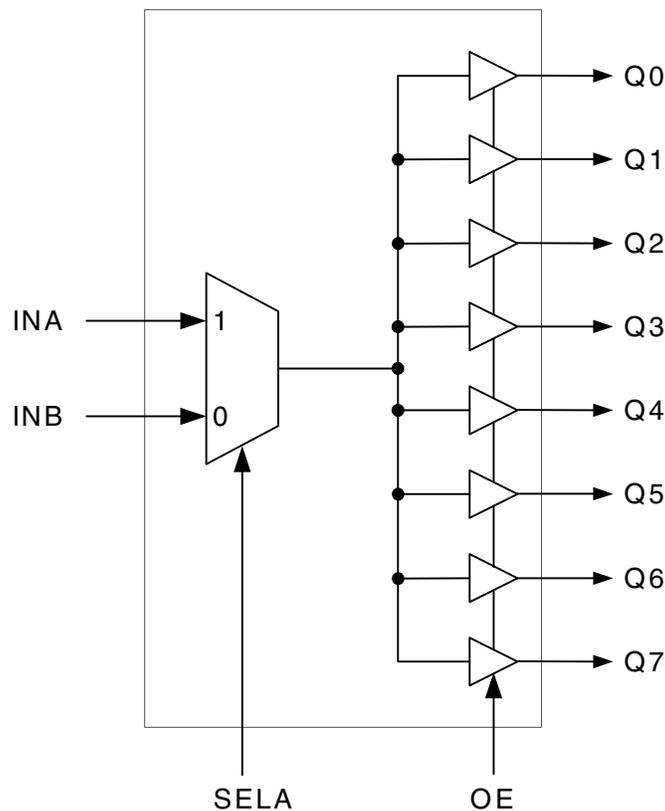

Pin Assignments

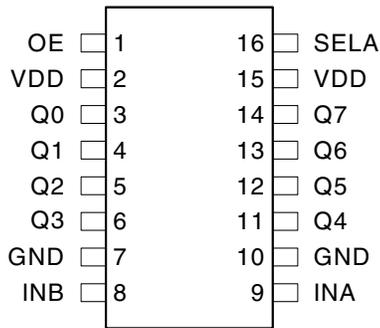

16 Pin TSSOP

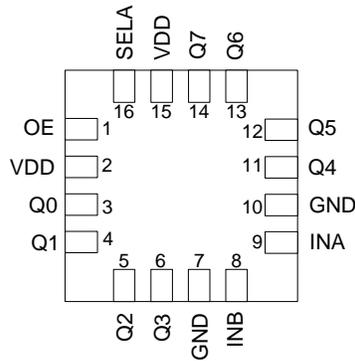

16-pin VFQFN

Input Source Select

SELA	Input
0	INB
1	INA

Pin Descriptions

Pin Number	Pin Name	Pin Type	Pin Description
1	OE	Input	Output Enable. Tri-states outputs when low. Internal pull-up resistor.
2	VDD	Power	Connect to +1.8V, +2.5V or +3.3V. Must be the same as pin 15.
3	Q0	Output	Clock Output 0.
4	Q1	Output	Clock Output 1.
5	Q2	Output	Clock Output 2.
6	Q3	Output	Clock Output 3.
7	GND	Power	Connect to ground.
8	INB	Input	Clock Input B. 3.3V tolerant.
9	INA	Input	Clock Input A. 3.3V tolerant.
10	GND	Power	Connect to ground.
11	Q4	Output	Clock Output 4.
12	Q5	Output	Clock Output 5.
13	Q6	Output	Clock Output 6.
14	Q7	Output	Clock Output 7.
15	VDD	Power	Connect to +1.8V, +2.5V or +3.3V. Must be the same as pin 2.
16	SELA	Input	Selects either INA or INB. Internal pull-up resistor.

External Components

A minimum number of external components are required for proper operation. Decoupling capacitors of 0.01 μ F should be connected between VDD on pin 2 and GND on pin 7, and between VDD on pin 15 and GND on pin 10, as close to the device as possible. A 33 Ω series terminating resistor should be used on each clock output if the trace is longer than 1 inch.

To achieve the low output skews that the 552-02S is capable of, careful attention must be paid to board layout. Essentially, all 8 outputs must have identical terminations, identical loads, and identical trace geometries. If they do not, the output skew will be degraded. For example, using a 30 Ω series termination on one output (with 33 Ω on the others) will cause at least 15ps of skew.

Absolute Maximum Ratings

Stresses above the ratings listed below can cause permanent damage to the 552-02S. These ratings, which are standard values for IDT commercially rated parts, are stress ratings only. Functional operation of the device at these or any other conditions above those indicated in the operational sections of the specifications is not implied. Exposure to absolute maximum rating conditions for extended periods can affect product reliability. Electrical parameters are guaranteed only over the recommended operating temperature range.

Item	Rating
Supply Voltage, VDD	3.465V
All Inputs and Outputs	-0.5 V to 3.465V
Ambient Operating Temperature, Extended	-40 to +105°C
Storage Temperature	-65 to +150 °C
Junction Temperature	175 °C
Soldering Temperature	260 °C

Recommended Operation Conditions

Parameter	Min.	Typ.	Max.	Units
Ambient Operating Temperature, Extended	-40	–	+105	°C
Power Supply Voltage (measured in respect to GND)	+1.71		+3.465	V

DC Electrical Characteristics

VDD=1.8 V ±5%, Ambient temperature -40°C to +105°C, unless stated otherwise

Parameter	Symbol	Conditions	Min.	Typ.	Max.	Units
Operating Voltage	VDD		1.71		1.89	V
Input High Voltage, INA, INB	V _{IH}	Note 1	0.7xVDD		1.89	V
Input Low Voltage, INA, INB	V _{IL}	Note 1			0.3xVDD	V
Input High Voltage, OE, SELA	V _{IH}		0.7xVDD		VDD	V
Input Low Voltage, OE, SELA	V _{IL}				0.3xVDD	V
Output High Voltage	V _{OH}	I _{OH} = -10 mA	1.3			V
Output Low Voltage	V _{OL}	I _{OL} = 10 mA			0.35	V
Operating Supply Current	IDD	No load, 135 MHz		32		mA

VDD=2.5 V ±5%, Ambient temperature -40°C to +105°C, unless stated otherwise

Parameter	Symbol	Conditions	Min.	Typ.	Max.	Units
Operating Voltage	VDD		2.375		2.625	V
Input High Voltage, INA, INB	V _{IH}	Note 1	0.7xVDD		2.625	V
Input Low Voltage, INA, INB	V _{IL}	Note 1			0.3xVDD	V
Input High Voltage, OE, SELA	V _{IH}		0.7xVDD		VDD	V
Input Low Voltage, OE, SELA	V _{IL}				0.3xVDD	V
Output High Voltage	V _{OH}	I _{OH} = -16 mA	1.8			V
Output Low Voltage	V _{OL}	I _{OL} = 16 mA			0.5	V
Operating Supply Current	IDD	No load, 135 MHz		43		mA

VDD=3.3 V ±5%, Ambient temperature -40°C to +105°C, unless stated otherwise

Parameter	Symbol	Conditions	Min.	Typ.	Max.	Units
Operating Voltage	VDD		3.135		3.465	V
Input High Voltage, INA, INB	V _{IH}	Note 1	0.7xVDD		3.465	V
Input Low Voltage, INA, INB	V _{IL}	Note 1			0.3xVDD	V
Input High Voltage, OE, SELA	V _{IH}		0.7xVDD		VDD	V
Input Low Voltage, OE, SELA	V _{IL}				0.3xVDD	V
Output High Voltage	V _{OH}	I _{OH} = -25 mA	2.2			V
Output Low Voltage	V _{OL}	I _{OH} = 25 mA			0.7	V
Operating Supply Current	IDD	No load, 135 MHz		55		mA

AC Electrical Characteristics

VDD = 1.8V ±5%, Ambient Temperature -40°C to +105°C, unless stated otherwise

Parameter	Symbol	Conditions	Min.	Typ.	Max.	Units
Input Frequency			0		200	MHz
Output Rise Time	t _{OR}	0.36 to 1.44 V, C _L =5 pF		1	1.5	ns
Output Fall Time	t _{OF}	1.44 to 0.36 V, C _L =5 pF		1	1.5	ns
Start-up Time	t _{START-UP}	Part start-up time for valid outputs after VDD ramp-up			2	ms
Propagation Delay	Note 1	135MHz	2	2.5	3	ns
Buffer Additive Phase Jitter, RMS		125MHz, Integration Range: 12KHz-20MHz		50	65	ps
Output to output skew	Note 2	Rising edges at VDD/2		0	65	ps
Input A to Input B skew	Note 3			0	50	ps

VDD = 2.5V ±5%, Ambient Temperature -40°C to +105°C, unless stated otherwise

Parameter	Symbol	Conditions	Min.	Typ.	Max.	Units
Input Frequency			0		200	MHz
Output Rise Time	t _{OR}	0.5 to 2.0 V, C _L =5 pF		0.6	1.0	ns
Output Fall Time	t _{OF}	2.0 to 0.5 V, C _L =5 pF		0.6	1.0	ns
Start-up Time	t _{START-UP}	Part start-up time for valid outputs after VDD ramp-up			2	ms
Propagation Delay	Note 1	135MHz	2	2.7	3.5	ns
Buffer Additive Phase Jitter, RMS		125MHz, Integration Range: 12KHz-20MHz		50	65	ps
Output to output skew	Note 2	Rising edges at VDD/2		0	65	ps
Input A to Input B skew	Note 3			0	50	ps

VDD = 3.3V ±5%, Ambient Temperature -40°C to +105°C, unless stated otherwise

Parameter	Symbol	Conditions	Min.	Typ.	Max.	Units
Input Frequency			0		200	MHz
Output Rise Time	t _{OR}	0.66 to 2.64 V, C _L =5 pF		0.6	1.0	ns
Output Fall Time	t _{OF}	2.64 to 0.66 V, C _L =5 pF		0.6	1.0	ns
Start-up Time	t _{START-UP}	Part start-up time for valid outputs after VDD ramp-up			2	ms
Propagation Delay	Note 1	135MHz	2	2.5	3	ns
Buffer Additive Phase Jitter, RMS		125MHz, Integration Range: 12KHz-20MHz		50	65	ps
Output to output skew	Note 2	Rising edges at VDD/2		0	65	ps
Input A to Input B skew	Note 3			0	50	ps

Notes:

1. With rail-to-rail input clock.
2. Between any two outputs with equal loading.
3. Propagation delay matching through the part.
4. Duty cycle on outputs will match incoming clock duty cycle. Consult IDT for tight duty cycle clock generators.

Package Outline and Dimensions (16-pin VFQFN)

REVISIONS			
REV	DESCRIPTION	DATE	APPROVED
00	INITIAL RELEASE	04/03/14	JH
01	ADD PIN1 CHAMFER	12/11/14	JH

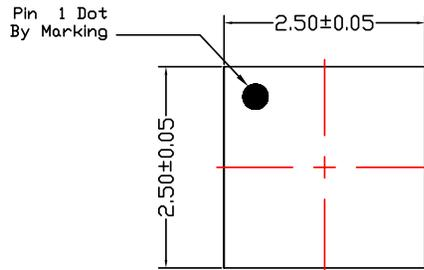

TOP VIEW

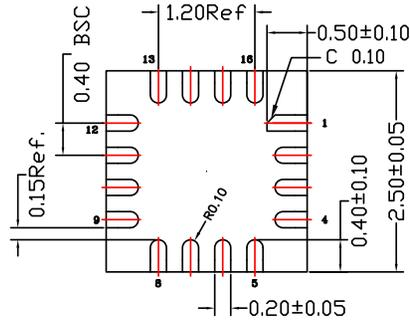

BOTTOM VIEW

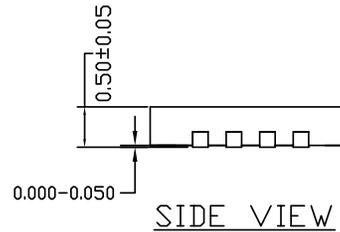

SIDE VIEW

NOTES:

1. ALL DIMENSIONING AND TOLERANCING CONFORM TO ANSI Y14.5M-1982
2. ALL DIMENSIONS ARE IN MILLIMETERS.

TOLERANCES UNLESS SPECIFIED		 6024 Silver Creek Valley Road San Jose CA 95138 PHONE: (408) 284-8200 www.IDT.com FAX: (408) 284-8591		
DECIMAL	ANGULAR			
X±	±1°			
XX±				
XXX±				
APPROVALS	DATE	TITLE		
DRAWN <i>[Signature]</i>	04/03/14	CMG 16 PACKAGE OUTLINE		
CHECKED		2.5 x 2.5 mm BODY		
		0.40 mm PITCH VFQFN		
		SIZE	DRAWING No.	REV
		C	PSC-4478	01
DO NOT SCALE DRAWING			SHEET 1 OF 2	

REVISIONS			
REV	DESCRIPTION	DATE	APPROVED
00	INITIAL RELEASE	04/03/14	JH
01	ADD PIN1 CHAMFER	12/11/14	JH

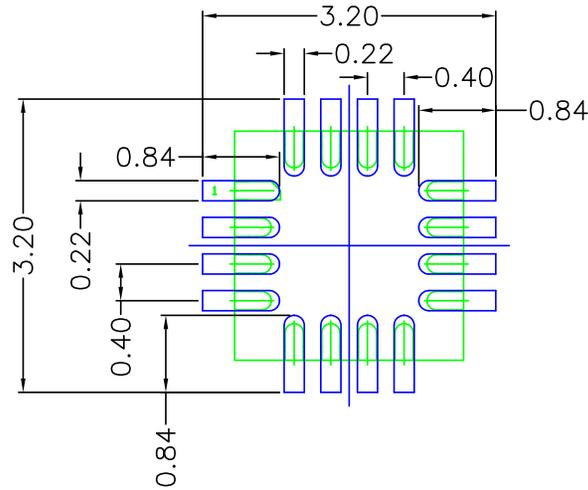

RECOMMENDED LAND PATTERN DIMENSION

NOTES:

1. ALL DIMENSIONS ARE IN MM. ANGLES IN DEGREES.
2. TOP DOWN VIEW AS VIEWED ON PCB.
3. COMPONENT OUTLINE IS SHOWN FOR REFERENCE IN GREEN.
4. LAND PATTERN IN BLUE. NSMD PATTERN ASSUMED.
5. LAND PATTERN RECOMMENDATION PER IPC-7351B GENERIC REQUIREMENT FOR SURFACE MOUNT DESIGN AND LAND PATTERN.

TOLERANCES UNLESS SPECIFIED		 6024 Silver Creek Valley Road San Jose CA 95138 PHONE: (408) 284-8200 FAX: (408) 284-8591 www.IDT.com
DECIMAL	ANGULAR	
X±	±1°	
XX±		
XXX±		
APPROVALS	DATE	TITLE
DRAWN <i>psr</i>	04/03/14	CMG 16 PACKAGE OUTLINE 2.5 x 2.5 mm BODY 0.40 mm PITCH VFQFN
CHECKED		
	SIZE	DRAWING No.
	C	PSC-4478
		REV
		01
DO NOT SCALE DRAWING		SHEET 2 OF 2

DATE CREATED	REVISIONS		
	REV	DESCRIPTION	AUTHOR
08/25/98	02	ADD 14 & 16 LD	T. VU
07/10/99	03	ADD 8 LD	T. VU
5/23/01	04	ADDED TOPMARK TO TITLE	
10/14/04	05	ADD "GREEN" PGG NOMENCLATURE	TU VU
3/8/13	06	ADDED PACKAGE CODE	RAC
9/3/14	07	ADD TOLERANCE FOR A, A1, E AND b	CK LEE
3/10/17	08	ADD OPTION T1	R.TANH

NOTE: REFER TO DCP FOR OFFICIAL RELEASE DATE

SYMBOL	PG/PGG8				NOTE	PG/PGG14				NOTE	PG/PGG16				NOTE	PG/PGG20				NOTE	PG/PGG24				NOTE	PG/PGG28				NOTE
	JEDEC VARIATION			MAX		JEDEC VARIATION			MAX		JEDEC VARIATION			MAX		JEDEC VARIATION			MAX		JEDEC VARIATION			MAX		JEDEC VARIATION			MAX	
	MIN	NOM	MAX			MIN	NOM	MAX			MIN	NOM	MAX			MIN	NOM	MAX			MIN	NOM	MAX			MIN	NOM	MAX		
A	.85	1.10	1.20		.85	1.10	1.20		.85	1.10	1.20		.85	1.10	1.20		.85	1.10	1.20		.85	1.10	1.20		.85	1.10	1.20			
A1	.05	.10	.15		.05	.10	.15		.05	.10	.15		.05	.10	.15		.05	.10	.15		.05	.10	.15		.05	.10	.15			
A2	.80	1.00	1.05		.80	1.00	1.05		.80	1.00	1.05		.80	1.00	1.05		.80	1.00	1.05		.80	1.00	1.05		.80	1.00	1.05			
D	2.90	3.00	3.10	4,5	4.90	5.00	5.10	4,5	4.90	5.00	5.10	4,5	6.40	6.50	6.60	4,5	7.70	7.80	7.90	4,5	9.60	9.70	9.80	4,5	9.60	9.70	9.80	4,5		
E	6.20	6.40	6.60	3	6.20	6.40	6.60	3	6.20	6.40	6.60	3	6.20	6.40	6.60	3	6.20	6.40	6.60	3	6.20	6.40	6.60	3	6.20	6.40	6.60	3		
E1	4.30	4.40	4.50	4,6	4.30	4.40	4.50	4,6	4.30	4.40	4.50	4,6	4.30	4.40	4.50	4,6	4.30	4.40	4.50	4,6	4.30	4.40	4.50	4,6	4.30	4.40	4.50	4,6		
e	.65 BSC				.65 BSC				.65 BSC				.65 BSC				.65 BSC				.65 BSC				.65 BSC					
b	.19	.25	.30		.19	.25	.30		.19	.25	.30		.19	.25	.30		.19	.25	.30		.19	.25	.30		.19	.25	.30			
b1	.19	.22	.25		.19	.22	.25		.19	.22	.25		.19	.22	.25		.19	.22	.25		.19	.22	.25		.19	.22	.25			
aaa	-	-	.10		-	-	.10		-	-	.10		-	-	.10		-	-	.10		-	-	.10		-	-	.10			
bbb	-	-	.10		-	-	.10		-	-	.10		-	-	.10		-	-	.10		-	-	.10		-	-	.10			
N	8				14				16				20				24				28									

NOTES:

- ALL DIMENSIONING AND TOLERANCING CONFORM TO ASME Y14.5M-1994
- DATUMS \square -A- AND \square -B- TO BE DETERMINED AT DATUM PLANE \square -H-
- DIMENSION E TO BE DETERMINED AT SEATING PLANE \square -C-
- DIMENSIONS D AND E1 ARE TO BE DETERMINED AT DATUM PLANE \square -H-
- DIMENSION D DOES NOT INCLUDE MOLD FLASH, PROTRUSIONS OR GATE BURRS. MOLD FLASH, PROTRUSIONS OR GATE BURRS SHALL NOT EXCEED .15 mm PER SIDE
- DIMENSION E1 DOES NOT INCLUDE INTERLEAD FLASH OR PROTRUSIONS. INTERLEAD FLASH OR PROTRUSIONS SHALL NOT EXCEED .25 mm PER SIDE
- DETAIL OF PIN 1 IDENTIFIER IS OPTIONAL BUT MUST BE LOCATED WITHIN THE ZONE INDICATED
- LEAD WIDTH DIMENSION DOES NOT INCLUDE DAMBAR PROTRUSION. ALLOWABLE DAMBAR PROTRUSION IS .08 mm IN EXCESS OF THE LEAD WIDTH DIMENSION AT MAXIMUM MATERIAL CONDITION. DAMBAR CANNOT BE LOCATED ON THE LOWER RADIUS OR THE FOOT
- THESE DIMENSIONS APPLY TO THE FLAT SECTION OF THE LEAD BETWEEN .10 AND .25 mm FROM THE LEAD TIP
- ALL DIMENSIONS ARE IN MILLIMETERS
- THIS OUTLINE CONFORMS TO JEDEC PUBLICATION 95 REGISTRATION MO-153, VARIATION AA, AB-1, AB, AC, AD & AE

SYMBOL	OPTION T1 PGG14T1			
	JEDEC VARIATION			NOTE
	MIN	NOM	MAX	
A	.90	1.10	1.20	
A1	.05	.10	.15	
A2	.80	1.00	1.05	
D	4.90	5.00	5.10	4,5
E	6.20	6.40	6.60	3
E1	4.30	4.40	4.50	4,6
e	.65 BSC			
b	.19	.25	.30	
b1	.19	.22	.25	
c	.09	-	.20	
aaa	-	-	.10	
bbb	-	-	.10	
N	14			

TOLERANCES UNLESS SPECIFIED DECIMAL ANGULAR XX± ± XXX± ± XXXX± ±	 2975 Stender Way Santa Clara, CA 95054 PHONE: (408) 727-6116 www.IDT.com FAX: (408) 492-8674	
TITLE PG/PGG PACKAGE OUTLINE (PG OR PA TOPMARK CODE) 4.4 mm BODY WIDTH TSSOP .65 mm PITCH		
SIZE C	DRAWING No. PSC-4056	REV 08
DO NOT SCALE DRAWING		SHEET 2 OF 3

LAND PATTERN DIMENSIONS

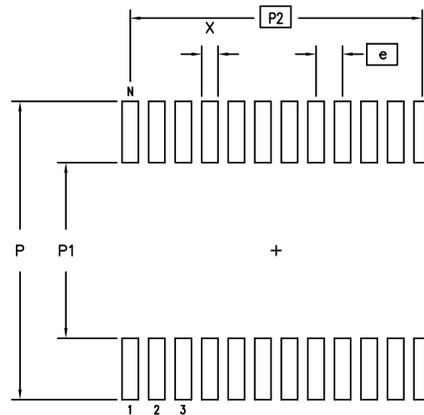

	MIN	MAX	MIN	MAX	MIN	MAX	MIN	MAX	MIN	MAX	MIN	MAX
P	7.20	7.40	7.20	7.40	7.20	7.40	7.20	7.40	7.20	7.40	7.20	7.40
P1	4.20	4.40	4.20	4.40	4.20	4.40	4.20	4.40	4.20	4.40	4.20	4.40
P2	1.95 BSC		3.90 BSC		4.55 BSC		5.85 BSC		7.15 BSC		8.45 BSC	
X	.30	.50	.30	.50	.30	.50	.30	.50	.30	.50	.30	.50
e	.65 BSC		.65 BSC		.65 BSC		.65 BSC		.65 BSC		.65 BSC	
N	8		14		16		20		24		28	

DATE CREATED	REVISIONS		
	REV	DESCRIPTION	AUTHOR
08/25/98	02	ADD 14 & 16 LD	T. VU
07/10/99	03	ADD 8 LD	T. VU
5/23/01	04	ADDED TOPMARK TO TITLE	
10/14/04	05	ADD "GREEN" PGG NOMENCLATURE	TU VU
3/8/13	06	ADDED PACKAGE CODE	RAC
9/3/14	07	ADD TOLERANCE FOR A, A1, E AND b	CK LEE
3/10/17	08	ADD OPTION T1	R.TANH

NOTE: REFER TO DCP FOR OFFICIAL RELEASE DATE

TOLERANCES UNLESS SPECIFIED DECIMAL ANGULAR XX± ± XXX± ± XXXX± ±	2975 Stender Way Santa Clara, CA 95054 PHONE: (408) 727-6116 FAX: (408) 492-8674 www.IDT.com
SIZE C	DRAWING No. PSC-4056
DO NOT SCALE DRAWING	REV 08 SHEET 3 OF 3

Ordering Information

Part / Order Number	Marking	Shipping Packaging	Package	Temperature
552-02SPGGI	TBD	Tubes	16-pin TSSOP	-40°C to +105°C
552-02SPGGI8		Tape and Reel	16-pin TSSOP	-40°C to +105°C
552-02SCMGI		Tubes	16-pin VFQFN	-40°C to +105°C
552-02SCMGI8		Tape and Reel	16-pin VFQFN	-40°C to +105°C

“G” after the two-letter package code denotes Pb-Free configuration, RoHS compliant.

Marking Diagrams

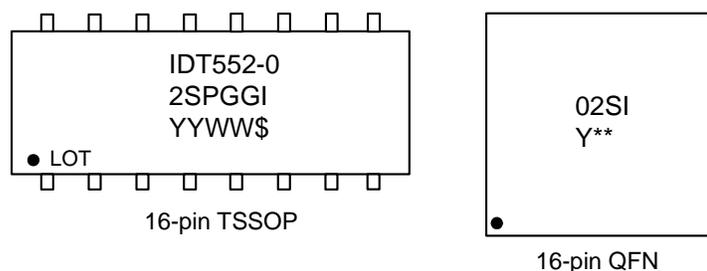

Notes:

1. “**” is the lot sequence.
2. “YYWW” or “Y” is the last digit(s) of the year and week that the part was assembled.
3. “\$” denotes the mark code.
4. “LOT” denotes lot number.
5. “G” after the two-letter package code denotes RoHS compliant package.
6. “I” denotes extended temperature range device.
7. Bottom marking: country of origin (TSSOP only).

Revision History

Rev.	Date	Originator	Description of Change
B	04/18/17	C.P.	1. Replaced package outline drawings with latest CMG16 and PGG16 versions. 2. Updated legal disclaimer.
A	07/11/16	H.G.	Release to final.

IMPORTANT NOTICE AND DISCLAIMER

RENESAS ELECTRONICS CORPORATION AND ITS SUBSIDIARIES (“RENESAS”) PROVIDES TECHNICAL SPECIFICATIONS AND RELIABILITY DATA (INCLUDING DATASHEETS), DESIGN RESOURCES (INCLUDING REFERENCE DESIGNS), APPLICATION OR OTHER DESIGN ADVICE, WEB TOOLS, SAFETY INFORMATION, AND OTHER RESOURCES “AS IS” AND WITH ALL FAULTS, AND DISCLAIMS ALL WARRANTIES, EXPRESS OR IMPLIED, INCLUDING, WITHOUT LIMITATION, ANY IMPLIED WARRANTIES OF MERCHANTABILITY, FITNESS FOR A PARTICULAR PURPOSE, OR NON-INFRINGEMENT OF THIRD-PARTY INTELLECTUAL PROPERTY RIGHTS.

These resources are intended for developers who are designing with Renesas products. You are solely responsible for (1) selecting the appropriate products for your application, (2) designing, validating, and testing your application, and (3) ensuring your application meets applicable standards, and any other safety, security, or other requirements. These resources are subject to change without notice. Renesas grants you permission to use these resources only to develop an application that uses Renesas products. Other reproduction or use of these resources is strictly prohibited. No license is granted to any other Renesas intellectual property or to any third-party intellectual property. Renesas disclaims responsibility for, and you will fully indemnify Renesas and its representatives against, any claims, damages, costs, losses, or liabilities arising from your use of these resources. Renesas' products are provided only subject to Renesas' Terms and Conditions of Sale or other applicable terms agreed to in writing. No use of any Renesas resources expands or otherwise alters any applicable warranties or warranty disclaimers for these products.

(Disclaimer Rev.1.01 Jan 2024)

Corporate Headquarters

TOYOSU FORESIA, 3-2-24 Toyosu,
Koto-ku, Tokyo 135-0061, Japan
www.renesas.com

Trademarks

Renesas and the Renesas logo are trademarks of Renesas Electronics Corporation. All trademarks and registered trademarks are the property of their respective owners.

Contact Information

For further information on a product, technology, the most up-to-date version of a document, or your nearest sales office, please visit www.renesas.com/contact-us/.