

Description

The 5P49V5907 is a programmable clock generator intended for high performance consumer, networking, industrial, computing, and data-communications applications. Configurations may be stored in on-chip One-Time Programmable (OTP) memory or changed using I²C interface. This is IDT's fifth generation of programmable clock technology (VersaClock[®] 5).

The frequencies are generated from a single reference clock or crystal. Two select pins allow up to 4 different configurations to be programmed and accessible using processor GPIOs or bootstrapping. The different selections may be used for different operating modes (full function, partial function, partial power-down), regional standards (US, Japan, Europe) or system production margin testing.

The device may be configured to use one of two I²C addresses to allow multiple devices to be used in a system.

Pin Assignment

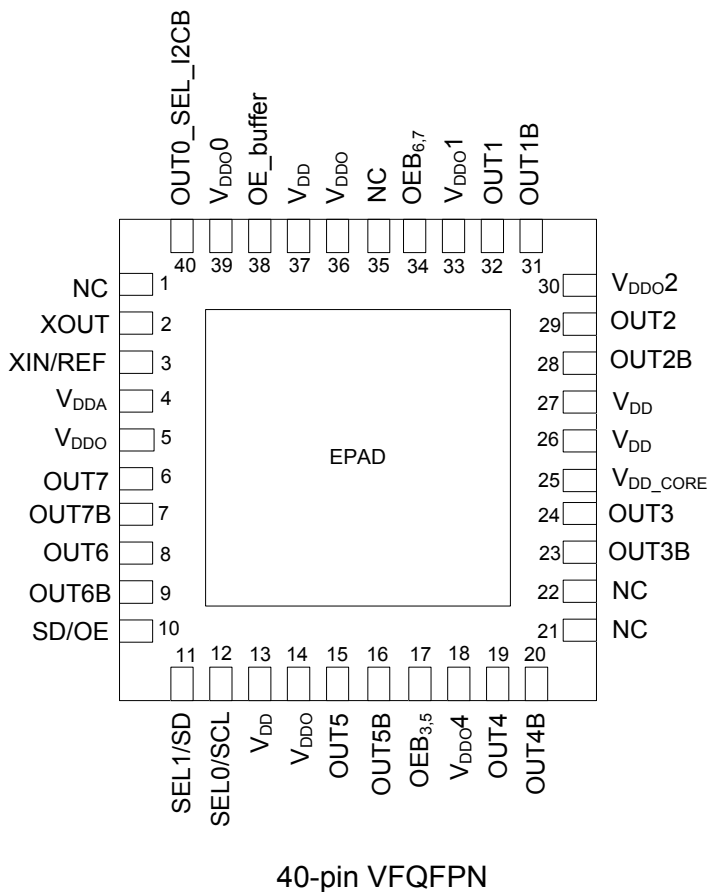

Features

- Generates up to four independent output frequencies with a total of 7 differential outputs and one reference output
- Supports multiple differential output I/O standards:
 - Three universal outputs pairs with each configurable as one differential output pair (LVDS, LVPECL or regular HCSL) or two LVCMOS outputs. Frequency of each output pair can be individually programmed
 - Four copies of Low Power HCSL(LP-HCSL) outputs.
- Programmable frequency:
 - See Output Features and Descriptions for details
- One reference LVCMOS output clock
- High performance, low phase noise PLL, <0.7 ps RMS typical phase jitter on outputs:
 - PCIe Gen1, 2, 3 compliant clock capability
 - USB 3.0 compliant clock capability
 - 1 GbE and 10 GbE
- Four fractional output dividers (FODs)
- Independent Spread Spectrum capability from each fractional output divider (FOD)
- Four banks of internal non-volatile in-system programmable or factory programmable OTP memory
- I²C serial programming interface
- Input frequency ranges:
 - LVCMOS Reference Clock Input (XIN/REF) – 1MHz to 200MHz
 - Crystal frequency range: 8MHz to 40MHz
- Output frequency ranges:
 - LVCMOS Clock Outputs – 1MHz to 200MHz
 - LP-HCSL Clock Outputs – 1MHz to 200MHz
 - Other Differential Clock Outputs – 1MHz to 350MHz
- Programmable loop bandwidth
- Programmable crystal load capacitance
- Power-down mode
- Mixed voltage operation:
 - 1.8V core
 - 1.8V VDDO for 4 LP-HCSL outputs
 - 1.8V to 3.3V VDDO for other outputs (3 programmable differential outputs and 1 reference output)
 - See Pin Descriptions for details
- Packaged in 40-pin 5mm x 5mm VFQFPN (NDG40)
- -40° to +85°C industrial temperature operation

Functional Block Diagram

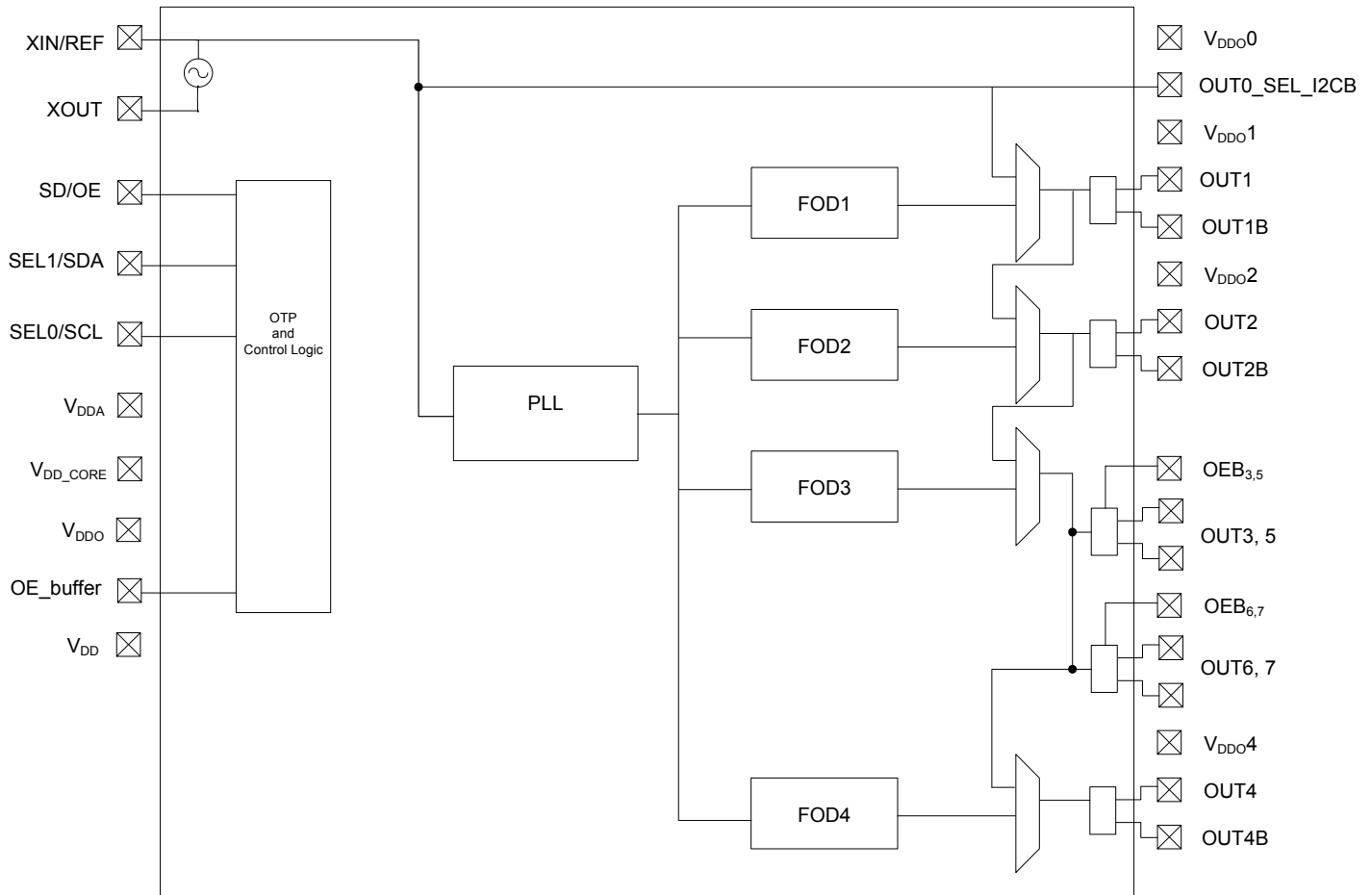

Applications

- Ethernet switch/router
- PCI Express 1.0/2.0/3.0
- Broadcast video/audio timing
- Multi-function printer
- Processor and FPGA clocking
- Any-frequency clock conversion
- MSAN/DSLAM/PON
- Fiber Channel, SAN
- Telecom line cards
- 1 GbE and 10 GbE

Table 1: Pin Descriptions

Number	Name	Type		Description
1	NC	Input		Do not connect
2	XOUT	Input		Crystal Oscillator interface output.
3	XIN/REF	Input		Crystal Oscillator interface input, or single-ended LVCMOS clock input. Ensure that the input voltage is 1.2V max. Refer to the section "Overdriving the XIN/REF Interface".
4	VDDA	Power		Analog functions power supply pin. Connect to 1.8V.
5	VDDO	Power		Connect to 1.8V. Power pin for outputs 3, 5-7
6	OUT7	Output		Output Clock 7. Low-Power HCSL (LP-HCSL) output.
7	OUT7B	Output		Complementary Output Clock 7. Low-Power HCSL (LP-HCSL) output..
8	OUT6	Output		Output Clock 6. Low-Power HCSL (LP-HCSL) output.
9	OUT6B	Output		Complementary Output Clock 6. Low-Power HCSL (LP-HCSL) output..
10	SD/OE	Input	Internal Pull-down	Enables/disables the outputs (OE) or powers down the chip (SD). The SH bit controls the configuration of the SD/OE pin. The SH bit needs to be high for SD/OE pin to be configured as SD. The SP bit (0x02) controls the polarity of the signal to be either active HIGH or LOW only when pin is configured as OE (Default is active LOW.) Weak internal pull down resistor. When configured as SD, device is shut down, differential outputs are driven high/low, and the single-ended LVCMOS outputs are driven low. When configured as OE, and outputs are disabled, the outputs can be selected to be tri-stated or driven high/low, depending on the programming bits as shown in the SD/OE Pin Function Truth table.
11	SEL1/SDA	Input	Internal Pull-down	Configuration select pin, or I2C SDA input as selected by OUT0_SEL_I2CB. Weak internal pull down resistor.
12	SEL0/SCL	Input	Internal Pull-down	Configuration select pin, or I2C SCL input as selected by OUT0_SEL_I2CB. Weak internal pull down resistor.
13	VDD	Power		Connect to 1.8V
14	VDDO	Power		Connect to 1.8V. Power pin for outputs 3, 5-7.
15	OUT5	Output		Output Clock 5. Low-Power HCSL (LP-HCSL) output.
16	OUT5B	Output		Complementary Output Clock 5. Low-Power HCSL (LP-HCSL) output.
17	OEB _{3,5}	Input	Internal Pull-down	Active low Output Enable pin for Outputs 3 and 5. 1=disable outputs, 0=enable outputs. This pin has internal pull-down.
18	VDDO4	Power		Connect to 1.8V to 3.3V. VDD supply for OUT4.
19	OUT4	Output		Output Clock 4. Please refer to the Output Drivers section for more details.
20	OUT4B	Output		Complementary Output Clock 4. Please refer to the Output Drivers section for more details.
21	NC	—		Do not connect
22	NC	—		Do not connect
23	OUT3B	Output		Complementary Output Clock 3. Low-Power HCSL (LP-HCSL) output.
24	OUT3	Output		Output Clock 3. HCSL Low-Power HCSL (LP-HCSL) output..
25	VDD_Core	Power		Connect to 1.8V
26	VDD	Power		Connect to 1.8V
27	VDD	Power		Connect to 1.8V
28	OUT2B	Output		Complementary Output Clock 2. Please refer to the Output Drivers section for more details.
29	OUT2	Output		Output Clock 2. Please refer to the Output Drivers section for more details.
30	VDDO2	Power		Connect to 1.8V to 3.3V. VDD supply for OUT2.
31	OUT1B	Output		Complementary Output Clock 1. Please refer to the Output Drivers section for more details.
32	OUT1	Output		Output Clock 1. Please refer to the Output Drivers section for more details.
33	VDDO1	Power		Connect to 1.8V to 3.3V. VDD supply for OUT1.
34	OEB _{6,7}	Input	Internal Pull-down	Active low Output Enable pin for Outputs 6 and 7. 1=disable outputs, 0=enable outputs. This pin has internal pull-down.
35	NC	—		Do not connect

Pin Descriptions (cont.)

Number	Name	Type		Description
36	VDDO	Power		Connect to 1.8V. Power pin for outputs 3, 5-7
37	VDD	Power		Connect to 1.8V.
38	OE_buffer		Internal Pull-up	Active High Output enable for outputs 3, 5-7. 0=disable outputs. 1=enable outputs. This pin has internal pull-up.
39	VDDO0	Power		Power supply pin for OUT0_SEL_I2CB. Connect to 1.8 to 3.3V. Sets output voltage levels for OUT0.
40	OUT0_SEL_I2CB	Output	Internal Pull-down	Latched input/LVCMOS Output. At power up, the voltage at the pin OUT0_SEL_I2CB is latched by the part and used to select the state of pins 11 and 12. If a weak pull up (10Kohms) is placed on OUT0_SEL_I2CB, pins 11 and 12 will be configured as hardware select pins, SEL1 and SEL0. If a weak pull down (10Kohms) is placed on OUT0_SEL_I2CB or it is left floating, pins 11 and 12 will act as the SDA and SCL pins of an I2C interface. After power up, the pin acts as a LVCMOS reference output.
ePAD	GND	GND		Connect to ground pad

PLL Features and Descriptions

Spread Spectrum

To help reduce electromagnetic interference (EMI), the 5P49V5907 supports spread spectrum modulation. The output clock frequencies can be modulated to spread energy across a broader range of frequencies, lowering system EMI. The 5P49V5907 implements spread spectrum using the Fractional-N output divide, to achieve controllable modulation rate and spreading magnitude. The Spread spectrum can be applied to any output divider and any spread amount from $\pm 0.25\%$ to $\pm 2.5\%$ center spread and -0.5% to -5% down spread.

Table 2: Loop Filter

PLL loop bandwidth range depends on the input reference frequency (Fref) and can be set between the loop bandwidth range as shown in the table below.

Input Reference Frequency—Fref (MHz)	Loop Bandwidth Min (kHz)	Loop Bandwidth Max (kHz)
5	40	126
350	300	1000

Table 3: Configuration Table

This table shows the SEL1, SEL0 settings to select the configuration stored in OTP. Four configurations can be stored in OTP. These can be factory programmed or user programmed.

OUT0_SEL_I2CB @ POR	SEL1	SEL0	I ² C Access	REG0:7	Config
1	0	0	No	0	0
1	0	1	No	0	1
1	1	0	No	0	2
1	1	1	No	0	3
0	X	X	Yes	1	I2C defaults
0	X	X	Yes	0	0

At power up time, the SEL0 and SEL1 pins must be tied to either the VDDA power supply so that they ramp with that supply or are tied low (this is the same as floating the pins). This will cause the register configuration to be loaded that is selected according to Table 3 above. Providing that OUT0_SEL_I2CB was 1 at POR and OTP register 0:7=0, after the first 10mS of operation the levels of the SELx pins can be changed, either to low or to the same level as VDDA. The SELx pins must be driven with a digital signal of < 300ns Rise/Fall time and only a single pin can be changed at a time. After a pin level change, the device must not be interrupted for at least 1ms so that the new values have time to load and take effect.

If OUT0_SEL_I2CB was 0 at POR, alternate configurations can only be loaded via the I2C interface.

Crystal Input (XIN/REF)

The crystal used should be a fundamental mode quartz crystal; overtone crystals should not be used.

A crystal manufacturer will calibrate its crystals to the nominal frequency with a certain load capacitance value. When the oscillator load capacitance matches the crystal load capacitance, the oscillation frequency will be accurate. When the oscillator load capacitance is lower than the crystal load capacitance, the oscillation frequency will be higher than nominal and vice versa so for an accurate oscillation frequency you need to make sure to match the oscillator load capacitance with the crystal load capacitance.

To set the oscillator load capacitance there are two tuning capacitors in the IC, one at XIN and one at XOUT. They can be adjusted independently but commonly the same value is used for both capacitors. The value of each capacitor is composed of a fixed capacitance amount plus a variable capacitance amount set with the XTAL[5:0] register. Adjustment of the crystal tuning capacitors allows for maximum flexibility to accommodate crystals from various manufacturers. The range of tuning capacitor values available are in accordance with the following table.

XTAL[5:0] Tuning Capacitor Characteristics

Parameter	Bits	Step (pF)	Min (pF)	Max (pF)
XTAL	6	0.5	9	25

The capacitance at each crystal pin inside the chip starts at 9pF with setting 000000b and can be increased up to 25pF with setting 111111b. The step per bit is 0.5pF.

You can write the following equation for this capacitance:

$$C_i = 9\text{pF} + 0.5\text{pF} \times \text{XTAL}[5:0]$$

The PCB where the IC and the crystal will be assembled adds some stray capacitance to each crystal pin and more capacitance can be added to each crystal pin with additional external capacitors.

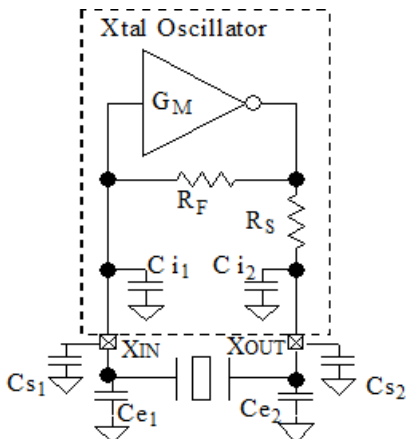

You can write the following equations for the total capacitance at each crystal pin:

$$C_{XIN} = C_{i1} + C_{s1} + C_{e1}$$

$$C_{XOUT} = C_{i2} + C_{s2} + C_{e2}$$

C_{i1} and C_{i2} are the internal, tunable capacitors. C_{s1} and C_{s2} are stray capacitances at each crystal pin and typical values are between 1pF and 3pF.

C_{e1} and C_{e2} are additional external capacitors that can be added to increase the crystal load capacitance beyond the tuning range of the internal capacitors. However, increasing the load capacitance reduces the oscillator gain so please consult the factory when adding C_{e1} and/or C_{e2} to avoid crystal startup issues. C_{e1} and C_{e2} can also be used to adjust for unpredictable stray capacitance in the PCB.

The final load capacitance of the crystal:

$$C_L = C_{XIN} \times C_{XOUT} / (C_{XIN} + C_{XOUT})$$

For most cases it is recommended to set the value for capacitors the same at each crystal pin:

$$C_{XIN} = C_{XOUT} = C_x \rightarrow C_L = C_x / 2$$

The complete formula when the capacitance at both crystal pins is the same:

$$C_L = (9\text{pF} + 0.5\text{pF} \times \text{XTAL}[5:0] + C_s + C_e) / 2$$

Example 1: The crystal load capacitance is specified as 8pF and the stray capacitance at each crystal pin is $C_s=1.5\text{pF}$. Assuming equal capacitance value at XIN and XOUT, the equation is as follows:

$$8\text{pF} = (9\text{pF} + 0.5\text{pF} \times \text{XTAL}[5:0] + 1.5\text{pF}) / 2 \rightarrow$$

$$0.5\text{pF} \times \text{XTAL}[5:0] = 5.5\text{pF} \rightarrow \text{XTAL}[5:0] = 11 \text{ (decimal)}$$

Example 2: The crystal load capacitance is specified as 12pF and the stray capacitance C_s is unknown. Footprints for external capacitors C_e are added and a worst case C_s of 5pF is used. For now we use $C_s + C_e = 5\text{pF}$ and the right value for C_e can be determined later to make 5pF together with C_s .

$$12\text{pF} = (9\text{pF} + 0.5\text{pF} \times \text{XTAL}[5:0] + 5\text{pF}) / 2 \rightarrow$$

$$\text{XTAL}[5:0] = 20 \text{ (decimal)}$$

OTP Interface

The 5P49V5907 can also store its configuration in an internal OTP. The contents of the device's internal programming registers can be saved to the OTP by setting burn_start (W114[3]) to high and can be loaded back to the internal programming registers by setting usr_rd_start(W114[0]) to high.

To initiate a save or restore using I²C, only two bytes are transferred. The Device Address is issued with the read/write bit set to “0”, followed by the appropriate command code. The save or restore instruction executes after the STOP condition is issued by the Master, during which time the 5P49V5907 will not generate Acknowledge bits. The 5P49V5907 will acknowledge the instructions after it has completed execution of them. During that time, the I²C bus should be interpreted as busy by all other users of the bus.

On power-up of the 5P49V5907, an automatic restore is performed to load the OTP contents into the internal programming registers. The 5P49V5907 will be ready to accept a programming instruction once it acknowledges its 7-bit I²C address.

Availability of Primary and Secondary I²C addresses to allow programming for multiple devices in a system. The I²C slave address can be changed from the default 0xD4 to 0xD0 by programming the I2C_ADDR bit D0. *VersaClock 5 Programming Guide* provides detailed I²C programming guidelines and register map.

SD/OE Pin Function

The polarity of the SD/OE signal pin can be programmed to be either active HIGH or LOW with the SP bit (W16[1]). When SP is “0” (default), the pin becomes active LOW and when SP is “1”, the pin becomes active HIGH. The SD/OE pin can be configured as either to shutdown the PLL or to enable/disable the outputs. The SH bit controls the configuration of the SD/OE pin. The SH bit needs to be high for SD/OE pin to be configured as SD.

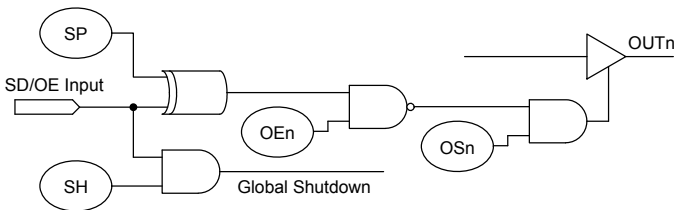

When configured as SD, device is shut down, differential outputs are driven High/low, and the single-ended LVCMOS outputs are driven low. When configured as OE, and outputs are disabled, the outputs are driven high/low.

Table 4: SD/OE Pin Function Truth Table

SH bit	SP bit	OSn bit	OEn bit	SD/OE	OUTn
0	0	0	x	x	Tri-state ²
0	0	1	0	x	Output active
0	0	1	1	0	Output active
0	0	1	1	1	Output driven High Low
0	1	0	x	x	Tri-state ²
0	1	1	0	x	Output active
0	1	1	1	0	Output driven High Low
0	1	1	1	1	Output active
1	0	0	x	0	Tri-state ²
1	0	1	0	0	Output active
1	0	1	1	0	Output active
1	1	0	x	0	Tri-state ²
1	1	1	0	0	Output active
1	1	1	1	0	Output driven High Low
1	x	x	x	1	Output driven High Low ¹

Note 1 : Global Shutdown

Note 2 : Tri-state regardless of OEn bits

Output Alignment

Each output divider block has a synchronizing POR pulse to provide startup alignment between outputs. This allows alignment of outputs for low skew performance. The phase alignment works both for integer output divider values and for fractional output divider values.

Besides the POR at power up, the same synchronization reset is also triggered when switching between configurations with the SEL0/1 pins. This ensures that the outputs remain aligned in every configuration. This reset causes the outputs to suspend for a few hundred microseconds so the switchover is not glitch-less. The reset can be disabled for applications where glitch-less switch over is required and alignment is not critical.

When using I²C to reprogram an output divider during operation, alignment can be lost. Alignment can be restored by manually triggering the reset through I²C.

When alignment is required for outputs with different frequencies, the outputs are actually aligned on the falling edges of each output by default. Rising edge alignment can also be achieved by utilizing the programmable skew feature to delay the faster clock by 180 degrees. The programmable skew feature also allows for fine tuning of the alignment.

For details of register programming, please see [VersaClock 5 Family Register Descriptions and Programming Guide](#) for details.

Output Divides

Each of the four output divides are comprised of a 12-bit integer counter, and a 24-bit fractional counter. The output divide can operate in integer divide only mode for improved performance, or utilize the fractional counters to generate any frequency with a synthesis accuracy better than 50ppb.

The Output Divide also has the capability to apply a spread modulation to the output frequency. Independent of output frequency, a triangle wave modulation between 30 and 63kHz may be generated.

Output Skew

For outputs that share a common output divide value, there will be the ability to skew outputs by quadrature values to minimize interaction on the PCB. The skew on each output can be adjusted from 0 to 360 degrees. Skew is adjusted in units equal to 1/32 of the VCO period. So, for 100 MHz output and a 2800 MHz VCO, you can select how many 11.161pS units you want added to your skew (resulting in units of 0.402 degrees). For example, 0, 0.402, 0.804, 1.206, 1.408, and so on. The granularity of the skew adjustment is always dependent on the VCO period and the output period.

Output Drivers

The OUT1 to OUT4 clock outputs are provided with register-controlled output drivers. By selecting the output drive type in the appropriate register, any of these outputs can support LVCMOS, LVPECL, HCSL or LVDS logic levels

The operating voltage ranges of each output is determined by its independent output power pin (V_{DDO}) and thus each can have different output voltage levels. Output voltage levels of 2.5V or 3.3V are supported for differential HCSL, LVPECL operation, and 1.8V, 2.5V, or 3.3V are supported for LVCMOS and differential LVDS operation.

Each output may be enabled or disabled by register bits. When disabled an output will be in a logic 0 state as determined by the programming bit table shown on page 6.

LVCMOS Operation

When a given output is configured to provide LVCMOS levels, then both the OUTx and OUTxB outputs will toggle at the selected output frequency. All the previously described configuration and control apply equally to both outputs. Frequency, phase alignment, voltage levels and enable / disable status apply to both the OUTx and OUTxB pins. The OUTx and OUTxB outputs can be selected to be phase-aligned with each other or inverted relative to one another by register programming bits. Selection of phase-alignment may have negative effects on the phase noise performance of any part of the device due to increased simultaneous switching noise within the device.

Device Start-up & Reset Behavior

The 5P49V5907 has an internal power-up reset (POR) circuit. The POR circuit will remain active for a maximum of 10ms after device power-up.

Upon internal POR circuit expiring, the device will exit reset and begin self-configuration.

The device will load internal registers using the configuration stored in the internal One-Time Programmable (OTP) memory.

Once the full configuration has been loaded, the device will respond to accesses on the serial port and will attempt to lock the PLL to the selected source and begin operation.

Power Up Ramp Sequence

VDDA and VDD must ramp up together. VDD0-1, VDDO4, VDD_CORE and VDDO must ramp up before, or concurrently with, VDDA and VDD. All power supply pins must be connected to a power rail even if the output is unused. All power supplies must ramp in a linear fashion and ramp monotonically.

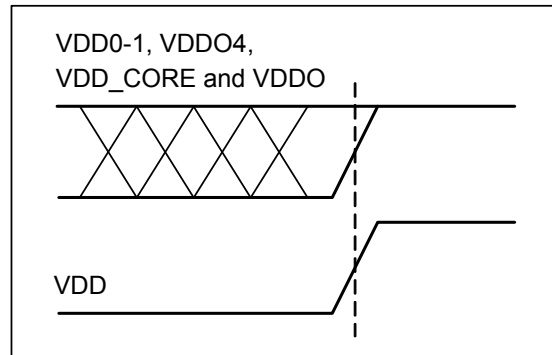

I²C Mode Operation

The device acts as a slave device on the I²C bus using one of the two I²C addresses (0xD0 or 0xD4) to allow multiple devices to be used in the system. The interface accepts byte-oriented block write and block read operations. Two address bytes specify the register address of the byte position of the first register to write or read. Data bytes (registers) are accessed in sequential order from the lowest to the highest byte (most significant bit first). Read and write block transfers can be stopped after any complete byte transfer. During a write operation, data will not be moved into the registers until the STOP bit is received, at which point, all data received in the block write will be written simultaneously.

For full electrical I²C compliance, it is recommended to use external pull-up resistors for SDATA and SCLK. The internal pull-down resistors have a size of 100kΩ typical.

Current Read

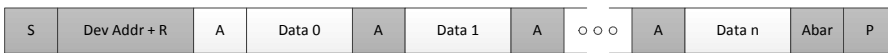

Sequential Read



Sequential Write



- from master to slave
- from slave to master
- S = start
- Sr = repeated start
- A = acknowledge
- Abar = none acknowledge
- P = stop

I²C Slave Read and Write Cycle Sequencing

Table 5: I²C Bus DC Characteristics

Symbol	Parameter	Conditions	Min	Typ	Max	Unit
V _{IH}	Input HIGH Level	For SEL1/SDA pin and SEL0/SCL pin.	0.7xV _{DDD}		5.5 ²	V
V _{IL}	Input LOW Level	For SEL1/SDA pin and SEL0/SCL pin.	GND-0.3		0.3xV _{DDD}	V
V _{HYS}	Hysteresis of Inputs		0.05xV _{DDD}			V
I _{IN}	Input Leakage Current		-1		30	μA
V _{OL}	Output LOW Voltage	I _{OL} = 3 mA			0.4	V

Table 6: I²C Bus AC Characteristics

Symbol	Parameter	Min	Typ	Max	Unit
F _{SCLK}	Serial Clock Frequency (SCL)	10		400	kHz
t _{BUF}	Bus free time between STOP and START	1.3			μs
t _{SU:START}	Setup Time, START	0.6			μs
t _{HD:START}	Hold Time, START	0.6			μs
t _{SU:DATA}	Setup Time, data input (SDA)	100			ns
t _{HD:DATA}	Hold Time, data input (SDA) ¹	0			μs
t _{OVD}	Output data valid from clock			0.9	μs
C _B	Capacitive Load for Each Bus Line			400	pF
t _R	Rise Time, data and clock (SDA, SCL)	20 + 0.1xC _B		300	ns
t _F	Fall Time, data and clock (SDA, SCL)	20 + 0.1xC _B		300	ns
t _{HIGH}	HIGH Time, clock (SCL)	0.6			μs
t _{LOW}	LOW Time, clock (SCL)	1.3			μs
t _{SU:STOP}	Setup Time, STOP	0.6			μs

Note 1: A device must internally provide a hold time of at least 300 ns for the SDA signal (referred to the V_{IH}(MIN) of the SCL signal) to bridge the undefined region of the falling edge of SCL.

Note 2: I²C inputs are 5V tolerant.

Table 7: Absolute Maximum Ratings

Stresses above the ratings listed below can cause permanent damage to the 5P49V5907. These ratings, which are standard values for IDT commercially rated parts, are stress ratings only. Functional operation of the device at these or any other conditions above those indicated in the operational sections of the specifications is not implied. Exposure to absolute maximum rating conditions for extended periods can affect product reliability. Electrical parameters are guaranteed only over the recommended operating temperature range.

Item	Rating
Supply Voltage, V_{DDA} , V_{DDO}	3.465V
Inputs XIN/REF	0V to 1.2V voltage swing
Outputs, V_{DDO} (LVCMOS)	-0.5V to $V_{DDO} + 0.5V$
Outputs, I_O (SDA)	10mA
Package Thermal Impedance, θ_{JA}	42°C/W (0 mps)
Package Thermal Impedance, θ_{JC}	41.8°C/W (0 mps)
Storage Temperature, T_{STG}	-65°C to 150°C
ESD Human Body Model	2000V
Junction Temperature	125°C

Table 8: Recommended Operation Conditions

Symbol	Parameter	Min	Typ	Max	Unit
V_{DDx}	Power supply voltage for supporting 1.8V outputs	1.71	1.8	1.89	V
V_{DDA}	Analog power supply voltage. Use filtered analog power supply if available.	1.71		1.89	V
T_A	Operating temperature, ambient	-40		85	°C
C_{LOAD_OUT}	Maximum load capacitance (3.3V LVCMOS only)			15	pF
F_{IN}	External reference crystal	8		40	MHz
t_{PU}	Power up time for all VDDs to reach minimum specified voltage (power ramps must be monotonic)	0.05		5	ms

Table 9: Input Capacitance, LVCMOS Output Impedance, and Internal Pull-down Resistance ($T_A = +25^\circ\text{C}$)

Symbol	Parameter	Min	Typ	Max	Unit
C_{IN}	Input Capacitance (SD/OE, SEL1/SDA, SEL0/SCL)		3	7	pF
Pull-down Resistor		100		300	k Ω
R_{OUT}	LVCMOS Output Driver Impedance ($V_{DDO} = 1.8V, 2.5V, 3.3V$)		17		Ω
XIN/REF	Programmable capacitance at XIN/REF	9		25	pF
XOUT	Programmable capacitance at XOUT	9		25	pF

Table 10: Crystal Characteristics

Parameter	Test Conditions	Minimum	Typical	Maximum	Units
Mode of Oscillation		Fundamental			
Frequency		8	25	40	MHz
Equivalent Series Resistance (ESR)			10	100	Ω
Shunt Capacitance				7	pF
Load Capacitance (CL) @ ≤ 25 MHz		6	8	12	pF
Load Capacitance (CL) > 25 to 40M		6		8	pF
Maximum Crystal Drive Level				100	μ W

Note: Typical crystal used is [FOX 603-25-150](#). For different reference crystal options please go to [www.foxonline.com](#).

Table 11: DC Electrical Characteristics

Symbol	Parameter	Test Conditions	Min	Typ	Max	Unit
Iddcore ³	Core Supply Current	100 MHz on all outputs, 25 MHz REFCLK		43		mA
Iddox	Output Buffer Supply Current	LVPECL, 350 MHz, 3.3V VDDOx		42	47	mA
		LVPECL, 350 MHz, 2.5V VDDOx		37	42	mA
		LVDS, 350 MHz, 3.3V VDDOx		18	21	mA
		LVDS, 350 MHz, 2.5V VDDOx		17	20	mA
		LVDS, 350 MHz, 1.8V VDDOx		16	19	mA
		HCSL, 250 MHz, 3.3V VDDOx, 2 pF load		29	33	mA
		HCSL, 250 MHz, 2.5V VDDOx, 2 pF load		28	33	mA
		LVC MOS, 50 MHz, 3.3V, VDDOx ^{1,2}		16	18	mA
		LVC MOS, 50 MHz, 2.5V, VDDOx ^{1,2}		14	16	mA
		LVC MOS, 50 MHz, 1.8V, VDDOx ^{1,2}		12	14	mA
		LVC MOS, 200 MHz, 3.3V VDDOx ¹		36	42	mA
		LVC MOS, 200 MHz, 2.5V VDDOx ^{1,2}		27	32	mA
LVC MOS, 200 MHz, 1.8V VDDOx ^{1,2}		16	19	mA		
Iddpd	Power Down Current	SD asserted, I2C Programming		10	14	mA

1. Single CMOS driver active.

2. Measured into a 5" 50 Ohm trace with 2 pF load.

3. Iddcore = IddA+ IddD, no loads.

Output Features and Descriptions

OUT1/OUT1B, OUT2/OUT2B, and OUT4/OUT4B can form three output pairs. Each output pair has individually programmable frequencies and can be configured as one differential pair (LVDS, LVPECL, regular HCSL) or two LVC MOS outputs. VDDO is individually selectable from 1.8V to 3.3V for LVDS and LVC MOS, and 2.5V to 3.3V for LVPECL and regular current-mode HCSL outputs. OUT3, 5-7 are four Low-Power HCSL(LP-HCSL) differential output pairs. They are the same frequency which can be individually programmed. They utilize the 1.8V LP-HCSL technology which can reduce supply current and termination resistor count. LP-HCSL outputs are from 1MHz to 200MHz and other differential outputs are from 1MHz to 350MHz.

Table 12: DC Electrical Characteristics for 3.3V LVCMOS ($V_{DDO} = 3.3V \pm 5\%$, $T_A = -40^\circ\text{C}$ to $+85^\circ\text{C}$)¹

Symbol	Parameter	Test Conditions	Min	Typ	Max	Unit
VOH	Output HIGH Voltage	IOH = -15mA	2.4		VDDO	V
VOL	Output LOW Voltage	IOL = 15mA			0.4	V
IOZDD	Output Leakage Current (OUT1,2,4)	Tri-state outputs, VDDO = 3.465V			5	μA
IOZDD	Output Leakage Current (OUT0)	Tri-state outputs, VDDO = 3.465V			30	μA
VIH	Input HIGH Voltage	Single-ended inputs - SD/OE	0.7xVDDD		VDDD + 0.3	V
VIL	Input LOW Voltage	Single-ended inputs - SD/OE	GND - 0.3		0.3xVDDD	V
VIH	Input HIGH Voltage	Single-ended input OUT0_SEL_I2CB	2		VDDO0 + 0.3	V
VIL	Input LOW Voltage	Single-ended input OUT0_SEL_I2CB	GND - 0.3		0.4	V
VIH	Input HIGH Voltage	Single-ended input - XIN/REF	0.8		1.2	V
VIL	Input LOW Voltage	Single-ended input - XIN/REF	GND - 0.3		0.4	V
TR/Tf	Input Rise/Fall Time	SD/OE, SEL1/SDA, SEL0/SCL			300	ns

1. See "Recommended Operating Conditions" table.

Table 13: DC Electrical Characteristics for 2.5V LVCMOS ($V_{DDO} = 2.5V \pm 5\%$, $T_A = -40^\circ\text{C}$ to $+85^\circ\text{C}$)

Symbol	Parameter	Test Conditions	Min	Typ	Max	Unit
VOH	Output HIGH Voltage	IOH = -12mA	0.7xVDDO			V
VOL	Output LOW Voltage	IOL = 12mA			0.4	V
IOZDD	Output Leakage Current (OUT1,2,4)	Tri-state outputs, VDDO = 2.625V			5	μA
IOZDD	Output Leakage Current (OUT0)	Tri-state outputs, VDDO = 2.625V			30	μA
VIH	Input HIGH Voltage	Single-ended inputs - SD/OE	0.7xVDDD		VDDD + 0.3	V
VIL	Input LOW Voltage	Single-ended inputs - SD/OE	GND - 0.3		0.3xVDDD	V
VIH	Input HIGH Voltage	Single-ended input OUT0_SEL_I2CB	1.7		VDDO0 + 0.3	V
VIL	Input LOW Voltage	Single-ended input OUT0_SEL_I2CB	GND - 0.3		0.4	V
VIH	Input HIGH Voltage	Single-ended input - XIN/REF	0.8		1.2	V
VIL	Input LOW Voltage	Single-ended input - XIN/REF	GND - 0.3		0.4	V
TR/Tf	Input Rise/Fall Time	SD/OE, SEL1/SDA, SEL0/SCL			300	ns

Table 14: DC Electrical Characteristics for 1.8V LVCMOS ($V_{DDO} = 1.8V \pm 5\%$, $T_A = -40^\circ\text{C}$ to $+85^\circ\text{C}$)

Symbol	Parameter	Test Conditions	Min	Typ	Max	Unit
V _{OH}	Output HIGH Voltage	IOH = -8mA	0.7 x V _{DDO}		V _{DDO}	V
V _{OL}	Output LOW Voltage	IOL = 8mA			0.25 x V _{DDO}	V
I _{ozDD}	Output Leakage Current (OUT1,2,4)	Tri-state outputs, VDDO = 3.465V			5	μA
	Output Leakage Current (OUT0)	Tri-state outputs, VDDO = 3.465V			30	
V _{IH}	Input HIGH Voltage	Single-ended inputs - SD/OE	0.7 * V _{DDD}		V _{DDD} + 0.3	V
V _{IL}	Input LOW Voltage	Single-ended inputs - SD/OE	GND - 0.3		0.3 * V _{DDD}	V
V _{IH}	Input HIGH Voltage	Single-ended input OUT0_SEL_I2CB	0.65 * V _{DDO0}		V _{DDO0} + 0.3	V
V _{IL}	Input LOW Voltage	Single-ended input OUT0_SEL_I2CB	GND - 0.3		0.4	V
V _{IH}	Input HIGH Voltage	Single-ended input - XIN/REF	0.8		1.2	V
V _{IL}	Input LOW Voltage	Single-ended input - XIN/REF	GND - 0.3		0.4	V
TR/Tf	Input Rise/Fall Time	SEL0/SCL			300	ns

Table 15: DC Electrical Characteristics for LVDS ($V_{DDO} = 3.3V \pm 5\%$ or $2.5V \pm 5\%$, $T_A = -40^\circ\text{C}$ to $+85^\circ\text{C}$)

Symbol	Parameter	Min	Typ	Max	Unit
$V_{OT}(+)$	Differential Output Voltage for the TRUE binary state	247		454	mV
$V_{OT}(-)$	Differential Output Voltage for the FALSE binary state	-247		-454	mV
ΔV_{OT}	Change in V_{OT} between Complimentary Output States			50	mV
V_{OS}	Output Common Mode Voltage (Offset Voltage)	1.125	1.25	1.375	V
ΔV_{OS}	Change in V_{OS} between Complimentary Output States			50	mV
I_{OS}	Outputs Short Circuit Current, V_{OUT+} or $V_{OUT-} = 0V$ or V_{DDO}		9	24	mA
I_{OSD}	Differential Outputs Short Circuit Current, $V_{OUT+} = V_{OUT-}$		6	12	mA

Table 16: DC Electrical Characteristics for LVDS ($V_{DDO} = 1.8V \pm 5\%$, $T_A = -40^\circ\text{C}$ to $+85^\circ\text{C}$)

Symbol	Parameter	Min	Typ	Max	Unit
$V_{OT}(+)$	Differential Output Voltage for the TRUE binary state	247		454	mV
$V_{OT}(-)$	Differential Output Voltage for the FALSE binary state	-247		-454	mV
ΔV_{OT}	Change in V_{OT} between Complimentary Output States			50	mV
V_{OS}	Output Common Mode Voltage (Offset Voltage)	0.8	0.875	0.95	V
ΔV_{OS}	Change in V_{OS} between Complimentary Output States			50	mV
I_{OS}	Outputs Short Circuit Current, V_{OUT+} or $V_{OUT-} = 0V$ or V_{DD}		9	24	mA
I_{OSD}	Differential Outputs Short Circuit Current, $V_{OUT+} = V_{OUT-}$		6	12	mA

Table 17: DC Electrical Characteristics for LVPECL ($V_{DDO} = 3.3V \pm 5\%$ or $2.5V \pm 5\%$, $T_A = -40^\circ\text{C}$ to $+85^\circ\text{C}$)

Symbol	Parameter	Min	Typ	Max	Unit
V_{OH}	Output Voltage HIGH, terminated through 50Ω tied to $V_{DD} - 2V$	$V_{DDO} - 1.19$		$V_{DDO} - 0.69$	V
V_{OL}	Output Voltage LOW, terminated through 50Ω tied to $V_{DD} - 2V$	$V_{DDO} - 1.94$		$V_{DDO} - 1.4$	V
V_{SWING}	Peak-to-Peak Output Voltage Swing	0.55		0.993	V

Table 18: Electrical Characteristics – DIF 0.7V Regular HCSL Outputs (TA = -40°C to +85°C)
 (For OUT1, OUT2 and OUT4 programmable differential output pairs when configured as HCSL outputs)

TA = T_{COM} or T_{IND}, Supply Voltage per VDD of normal operation conditions, See Test Loads for Loading Conditions

PARAMETER	SYMBOL	CONDITIONS	MIN	TYP	MAX	UNITS	NOTES
Slew rate	T _{rf}	Scope averaging on	1		4	V/ns	1, 2, 3
Slew rate matching	ΔT _{rf}	Slew rate matching, Scope averaging on			20	%	1, 2, 4
Voltage High	V _{HIGH}	Statistical measurement on single-ended signal using oscilloscope math function. (Scope averaging on)	660		850	mV	1,7
Voltage Low	V _{LOW}		-150		150		1,7
Max Voltage	V _{max}	Measurement on single ended signal using absolute value. (Scope averaging off)			1150	mV	1
Min Voltage	V _{min}		-300				1
Vswing	V _{swing}	Scope averaging off	300			mV	1,2,7
Crossing Voltage (abs)	V _{cross_abs}	Scope averaging off	250		550	mV	1,5,7
Crossing Voltage (var)	Δ-V _{cross}	Scope averaging off			140	mV	1, 6

¹Guaranteed by design and characterization, not 100% tested in production.

² Measured from differential waveform

³ Slew rate is measured through the V_{swing} voltage range centered around differential 0V. This results in a +/-150mV window around differential 0V.

⁴ Matching applies to rising edge rate for Clock and falling edge rate for Clock#. It is measured using a +/-75mV window centered on the average cross point where Clock rising meets Clock# falling. The median cross point is used to calculate the voltage thresholds the oscilloscope is to use for the edge rate calculations.

⁵ V_{cross} is defined as voltage where Clock = Clock# measured on a component test board and only applies to the differential rising edge (i.e. Clock rising and Clock# falling).

⁶ The total variation of all V_{cross} measurements in any particular system. Note that this is a subset of V_{cross_min/max} (V_{cross} absolute) allowed. The intent is to limit V_{cross} induced modulation by setting Δ-V_{cross} to be smaller than V_{cross} absolute.

⁷ At default SMBus settings.

Table 19: Electrical Characteristics—Low Power HCSL (LP-HCSL) Outputs

(For OUT3 and OUT5–7 LP-HCSL differential output pairs.)

TA = TAMB; Supply Voltage per VDD, VDDIO of normal operation conditions, See Test Loads for Loading Conditions

PARAMETER	SYMBOL	CONDITIONS	MIN	TYP	MAX	UNITS	NOTES
Slew rate	t_{RF}	Scope averaging on	1	2.5	4	V/ns	1,2,3
Slew rate matching	dV/dt	Slew rate matching, Scope averaging on		7	20	%	1,2,4
Voltage High	V_{HIGH}	Statistical measurement on single-ended signal using oscilloscope math function. (Scope averaging on)	660	0	850	mV	7
Voltage Low	V_{LOW}		-150	0	150		7
Max Voltage	Vmax	Measurement on single ended signal using absolute value. (Scope averaging off)		0	1150	mV	7
Min Voltage	Vmin		-300	0			7
Vswing	Vswing	Scope averaging off	300	0		mV	1,2
Crossing Voltage (abs)	Vcross_abs	Scope averaging off	250	0	550	mV	1,5
Crossing Voltage (var)	Δ -Vcross	Scope averaging off		0	140	mV	1,6

¹Guaranteed by design and characterization, not 100% tested in production.

² Measured from differential waveform

³ Slew rate is measured through the Vswing voltage range centered around differential 0V. This results in a +/-150mV window around differential 0V.

⁴ Matching applies to rising edge rate for Clock and falling edge rate for Clock#. It is measured using a +/-75mV window centered on the average cross point where Clock rising meets Clock# falling. The median cross point is used to calculate the voltage thresholds the oscilloscope is to use for the edge rate calculations.

⁵ Vcross is defined as voltage where Clock = Clock# measured on a component test board and only applies to the differential rising edge (i.e. Clock rising and Clock# falling).

⁶ The total variation of all Vcross measurements in any particular system. Note that this is a subset of Vcross_min/max (Vcross absolute) allowed. The intent is to limit Vcross induced modulation by setting Δ -Vcross to be smaller than Vcross absolute.

⁷ At default SMBus settings.

Table 20: AC Timing Electrical Characteristics ($V_{DDO} = 1.8V \pm 5\%$, $T_A = -40^{\circ}C$ to $+85^{\circ}C$)

(Spread Spectrum Generation = OFF)

Symbol	Parameter	Test Conditions	Min.	Typ.	Max.	Units
f_{IN}^1	Input Frequency	Input frequency limit (XIN)	8		40	MHz
		Input frequency limit (REF)	1		200	MHz
f_{OUT}	Output Frequency	Single ended clock output limit (LVCMOS)	1		200	MHz
		Differential clock output limit	1		350	
f_{VCO}	VCO Frequency	VCO operating frequency range	2500		2900	MHz
f_{PFD}	PFD Frequency	PFD operating frequency range	1 ¹		150	MHz
f_{BW}	Loop Bandwidth	Input frequency = 25MHz	0.06		0.9	MHz
t2	Input Duty Cycle	Duty Cycle	45		55	%
t3 ⁵	Output Duty Cycle	Measured at VDD/2, all outputs except Reference output OUT0, VDDOX= 2.5V or 3.3V	45	50	55	%
		Measured at VDD/2, all outputs except Reference output OUT0, VDDOX=1.8V	40	50	60	%
		Measured at VDD/2, Reference output OUT0 (5MHz - 120MHz) with 50% duty cycle input	40	50	60	%
		Measured at VDD/2, Reference output OUT0 (150.1MHz - 200MHz) with 50% duty cycle input	30	50	70	%
t4 ²	Slew Rate, SLEW[1:0] = 00	Single-ended 3.3V LVCMOS output clock rise and fall time, 20% to 80% of VDDO (Output Load = 5 pF) VDDOX=3.3V	1.0	2.2		V/ns
	Slew Rate, SLEW[1:0] = 01		1.2	2.3		
	Slew Rate, SLEW[1:0] = 10		1.3	2.4		
	Slew Rate, SLEW[1:0] = 11		1.7	2.7		
	Slew Rate, SLEW[1:0] = 00	Single-ended 2.5V LVCMOS output clock rise and fall time, 20% to 80% of VDDO (Output Load = 5 pF) VDDOX=2.5V	0.6	1.3		
	Slew Rate, SLEW[1:0] = 01		0.7	1.4		
	Slew Rate, SLEW[1:0] = 10		0.6	1.4		
	Slew Rate, SLEW[1:0] = 11		1.0	1.7		
	Slew Rate, SLEW[1:0] = 00	Single-ended 1.8V LVCMOS output clock rise and fall time, 20% to 80% of VDDO (Output Load = 5 pF) VDDOX=1.8V	0.3	0.7		
	Slew Rate, SLEW[1:0] = 01		0.4	0.8		
	Slew Rate, SLEW[1:0] = 10		0.4	0.9		
	Slew Rate, SLEW[1:0] = 11		0.7	1.2		
t5	Rise Times	LVDS, 20% to 80%		300		ps
	Fall Times	LVDS, 80% to 20%		300		
	Rise Times	LVPECL, 20% to 80%		400		
	Fall Times	LVPECL, 80% to 20%		400		

t6	Clock Jitter	Cycle-to-Cycle jitter (Peak-to-Peak), multiple output frequencies switching, differential outputs		46		ps
		Cycle-to-Cycle jitter (Peak-to-Peak), multiple output frequencies switching, LVCMOS outputs		74		ps
		RMS Phase Jitter (12kHz to 5MHz integration range) reference clock (OUT0), 25 MHz LVCMOS outputs		0.5		ps
		RMS Phase Jitter (12kHz to 20MHz integration range) differential output, 25MHz crystal, 156.25MHz output frequency		0.75	1.5	ps
t7	Output Skew between OUT1, OUT2, OUT4	Skew between the same frequencies , with outputs using the same driver format and phase delay set to 0 ns.		75		ps
	Output Skew between OUT3 and OUT5-11	Skew between outputs at same frequency and conditions	49.5		84	ps
t8 ³	Startup Time	PLL lock time from power-up, measured after all VDD's have raised above 90% of their target value.			10	ms
t9 ⁴	Startup Time	PLL lock time from shutdown mode			2	ms

1. Practical lower frequency is determined by loop filter settings.
2. A slew rate of 2.75V/ns or greater should be selected for output frequencies of 100MHz or higher.
3. Includes loading the configuration bits from EPROM to PLL registers. It does not include EPROM programming/w rite time.
4. Actual PLL lock time depends on the loop configuration.
5. Duty Cycle is only guaranteed at max slew rate settings.

Table 21: PCI Express Jitter Specifications ($V_{DDO} = 3.3V \pm 5\%$ or $2.5V \pm 5\%$, $T_A = -40^\circ C$ to $+85^\circ C$)

(For regular HCSL (OUT1, OUT2 and OUT4) outputs)

Symbol	Parameter	Conditions	Min	Typ	Max	PCIe Industry Specification	Units	Notes
t _J (PCIe Gen1)	Phase Jitter Peak-to-Peak	f = 100MHz, 25MHz Crystal Input Evaluation Band: 0Hz - Nyquist (clock frequency/2)		30		86	ps	1,4
t _{REFCLK_HF_RMS} (PCIe Gen2)	Phase Jitter RMS	f = 100MHz, 25MHz Crystal Input High Band: 1.5MHz - Nyquist (clock frequency/2)		2.56		3.10	ps	2,4
t _{REFCLK_LF_RMS} (PCIe Gen2)	Phase Jitter RMS	f = 100MHz, 25MHz Crystal Input Low Band: 10kHz - 1.5MHz		0.27		3.0	ps	2,4
t _{REFCLK_RMS} (PCIe Gen3)	Phase Jitter RMS	f = 100MHz, 25MHz Crystal Input Evaluation Band: 0Hz - Nyquist (clock frequency/2)		0.8		1.0	ps	3,4

Note: Electrical parameters are guaranteed over the specified ambient operating temperature range, which is established when the device is mounted in a test socket with maintained transverse airflow greater than 500 lfpm. The device will meet specifications after thermal equilibrium has been reached under these conditions.

1. Peak-to-Peak jitter after applying system transfer function for the Common Clock Architecture. Maximum limit for PCI Express Gen 1.
2. RMS jitter after applying the two evaluation bands to the two transfer functions defined in the Common Clock Architecture and reporting the worst case results for each evaluation band. Maximum limit for PCI Express Generation 2 is 3.1ps RMS for t_{REFCLK_HF_RMS} (High Band) and 3.0ps RMS for t_{REFCLK_LF_RMS} (Low Band).
3. RMS jitter after applying system transfer function for the common clock architecture. This specification is based on the PCI_Express_Base_r3.0 10 Nov, 2010 specification, and is subject to change pending the final release version of the specification.
4. This parameter is guaranteed by characterization. Not tested in production.

Table 22: PCI Express Jitter Specifications ($V_{DDO} = 1.8V \pm 5\%$, $T_A = -40^\circ C$ to $+85^\circ C$)
(For LP-HCSL (OUT3, OUT5-7) outputs.)

Symbol	Parameter	Conditions	Min	Typ	Max	PCIe Industry Specification	Units	Notes
t_j (PCIe Gen1)	Phase Jitter Peak-to-Peak	$f = 100MHz$, 25MHz Crystal Input Evaluation Band: 0Hz - Nyquist (clock frequency/2)		23.85		86	ps	1,4
$t_{REFCLK_HF_RMS}$ (PCIe Gen2)	Phase Jitter RMS	$f = 100MHz$, 25MHz Crystal Input High Band: 1.5MHz - Nyquist (clock frequency/2)		1.83		3.1	ps	2,4
$t_{REFCLK_LF_RMS}$ (PCIe Gen2)	Phase Jitter RMS	$f = 100MHz$, 25MHz Crystal Input Low Band: 10kHz - 1.5MHz		0.54		3	ps	2,4
t_{REFCLK_RMS} (PCIe Gen3)	Phase Jitter RMS	$f = 100MHz$, 25MHz Crystal Input Evaluation Band: 0Hz - Nyquist (clock frequency/2)		0.51		1	ps	3,4

Note: Electrical parameters are guaranteed over the specified ambient operating temperature range, which is established when the device is mounted in a test socket with maintained transverse airflow greater than 500 lfm. The device will meet specifications after thermal equilibrium has been reached under these conditions.

1. Peak-to-Peak jitter after applying system transfer function for the Common Clock Architecture. Maximum limit for PCI Express Gen 1.
2. RMS jitter after applying the two evaluation bands to the two transfer functions defined in the Common Clock Architecture and reporting the worst case results for each evaluation band. Maximum limit for PCI Express Generation 2 is 3.1ps RMS for $t_{REFCLK_HF_RMS}$ (High Band) and 3.0ps RMS for $t_{REFCLK_LF_RMS}$ (Low Band).
3. RMS jitter after applying system transfer function for the common clock architecture. This specification is based on the PCI_Express_Base_r3.0 10 Nov, 2010 specification, and is subject to change pending the final release version of the specification.
4. This parameter is guaranteed by characterization. Not tested in production.

Table 23: Spread Spectrum Generation Specifications

Symbol	Parameter	Description	Min	Typ	Max	Unit
f_{OUT}	Output Frequency	Output Frequency Range	1		300	MHz
f_{MOD}	Mod Frequency	Modulation Frequency	30 to 63			kHz
f_{SPREAD}	Spread Value	Amount of Spread Value (programmable) - Center Spread	$\pm 0.25\%$ to $\pm 2.5\%$			$\%f_{OUT}$
		Amount of Spread Value (programmable) - Down Spread	-0.5% to -5%			

5P49V5907 Reference Schematic

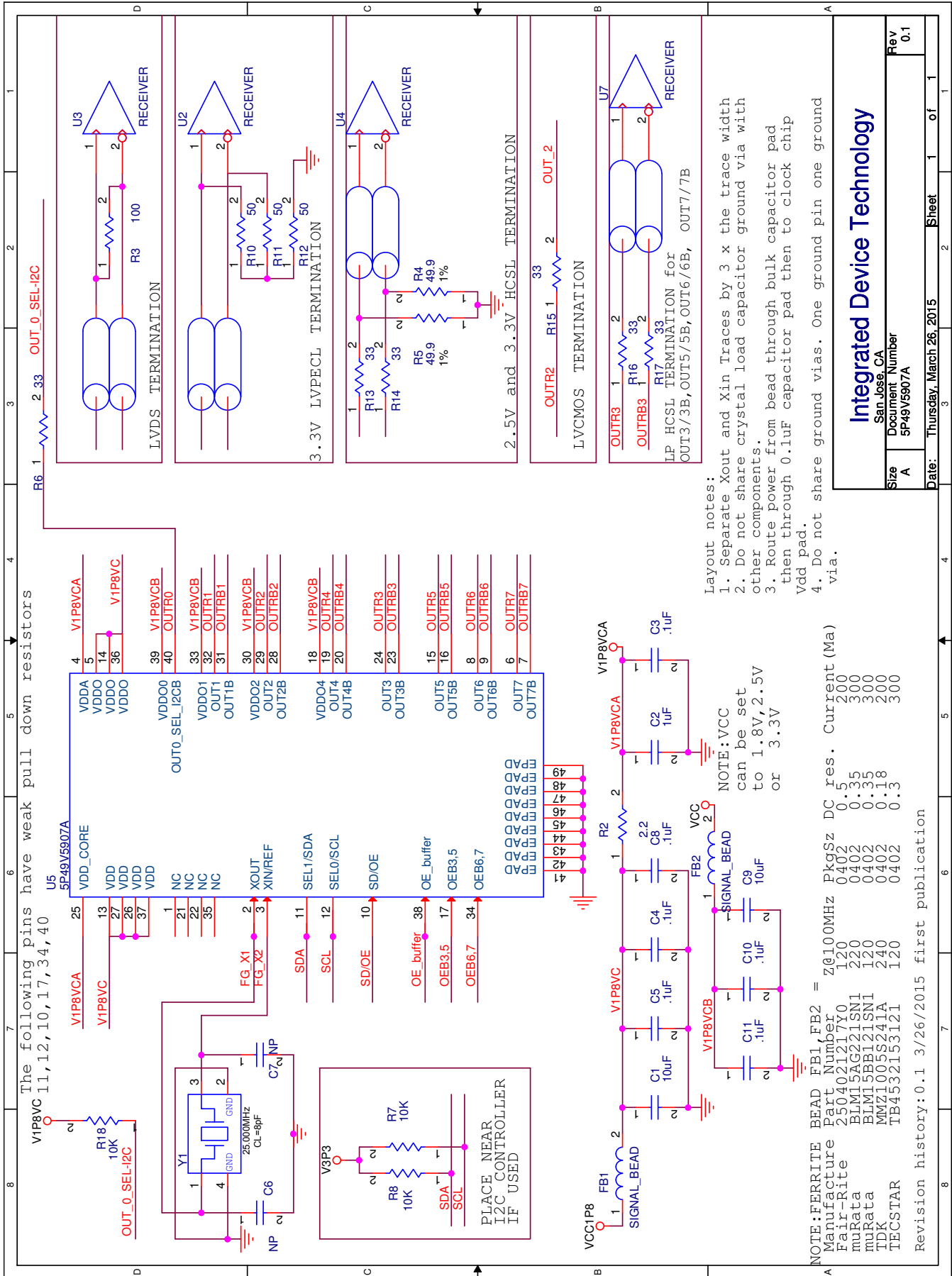

Layout notes:
 1. Separate Xout and Xin Traces by 3 x the trace width
 2. Do not share crystal load capacitor ground via with other components.
 3. Route power from bead through bulk capacitor pad then through 0.1uF capacitor pad then to clock chip Vdd pad.
 4. Do not share ground vias. One ground pin one ground via.

Integrated Device Technology	
San Jose, CA	
Document Number	5P49V5907A
Size	Rev
A	0.1

Test Circuits and Loads

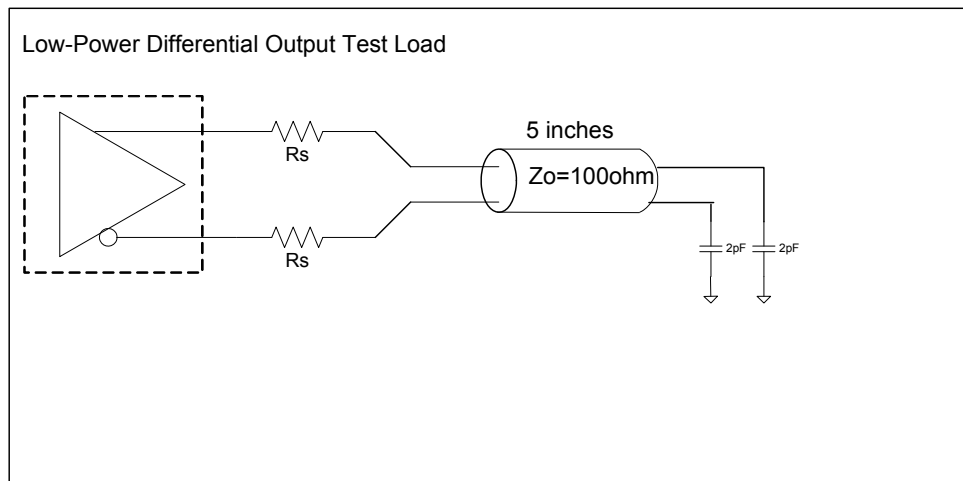
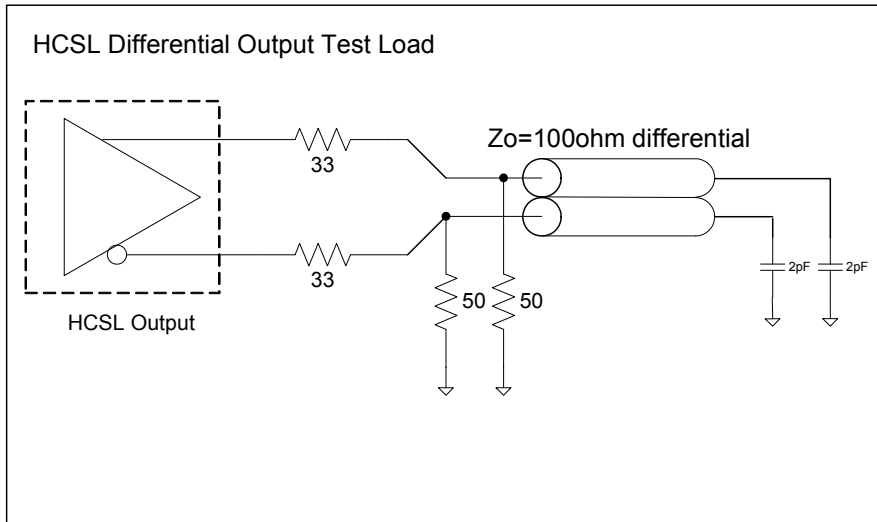
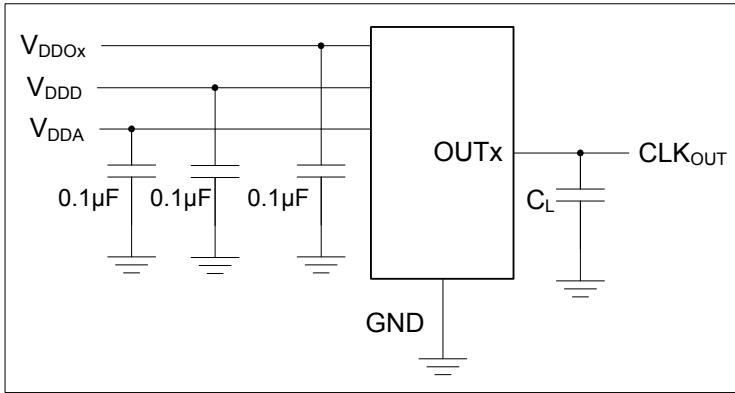

Alternate Differential Output Terminations

Rs	Zo	Units
33	100	Ohms
27	85	

Test Circuits and Loads for Outputs

Typical Phase Noise at 100MHz (3.3V, 25°C)

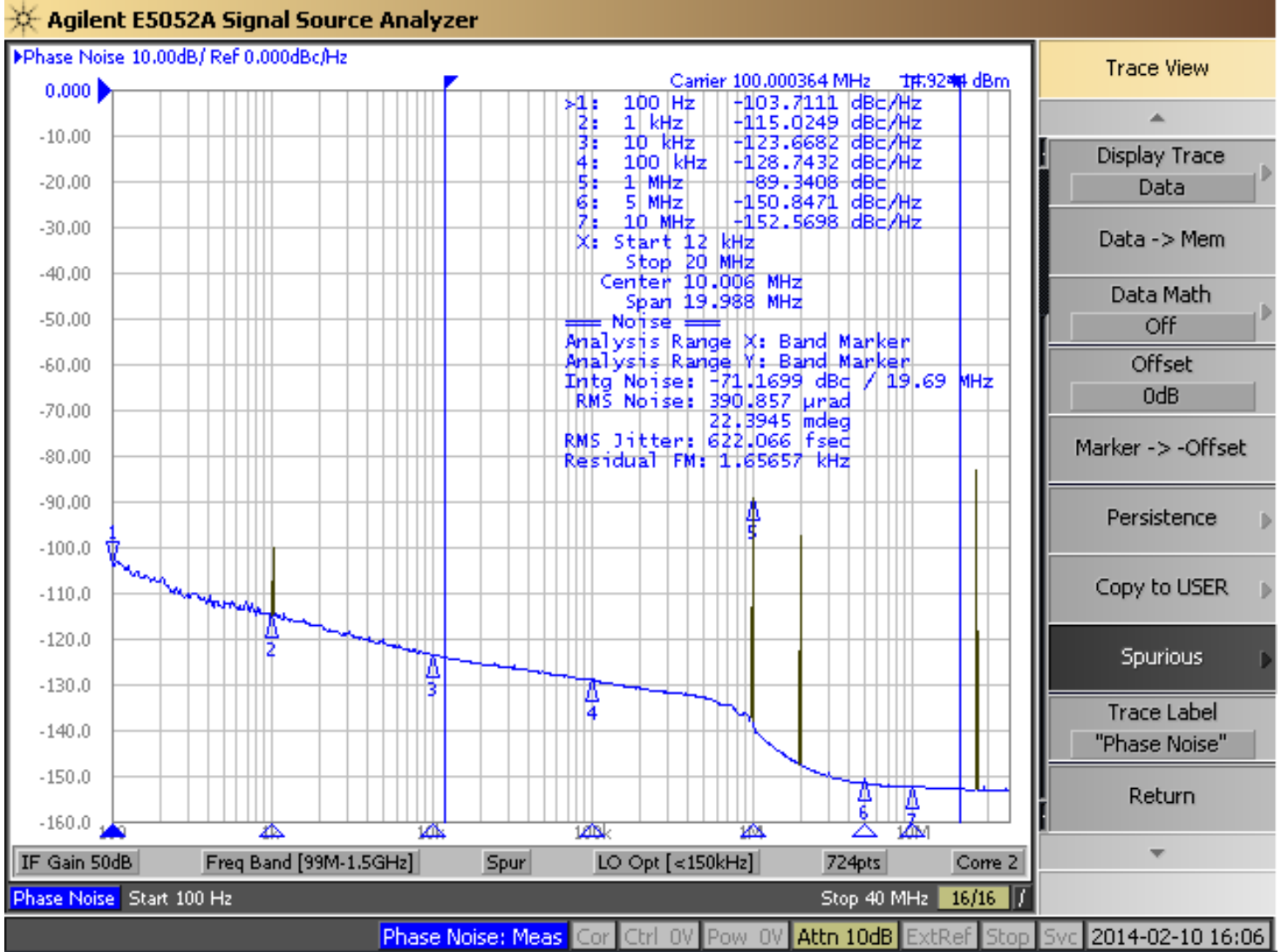

NOTE: All outputs operational at 100MHz, Phase Noise Plot with Spurs On.

Overdriving the XIN/REF Interface

LVC MOS Driver

The XIN/REF input can be overdriven by an LVC MOS driver or by one side of a differential driver through an AC coupling capacitor. The XOUT pin can be left floating. The amplitude of the input signal should be between 500mV and 1.2V and the slew rate should not be less than 0.2V/ns. Figure General Diagram for LVC MOS Driver to XTAL Input Interface shows an example of the interface diagram for a LVC MOS driver.

This configuration has three properties; the total output impedance of R_o and R_s matches the 50 ohm transmission line impedance, the V_{rx} voltage is generated at the CLKIN inputs which maintains the LVC MOS driver voltage level across the transmission line for best S/N and the R_1 - R_2 voltage divider values ensure that the clock level at XIN is less than the maximum value of 1.2V.

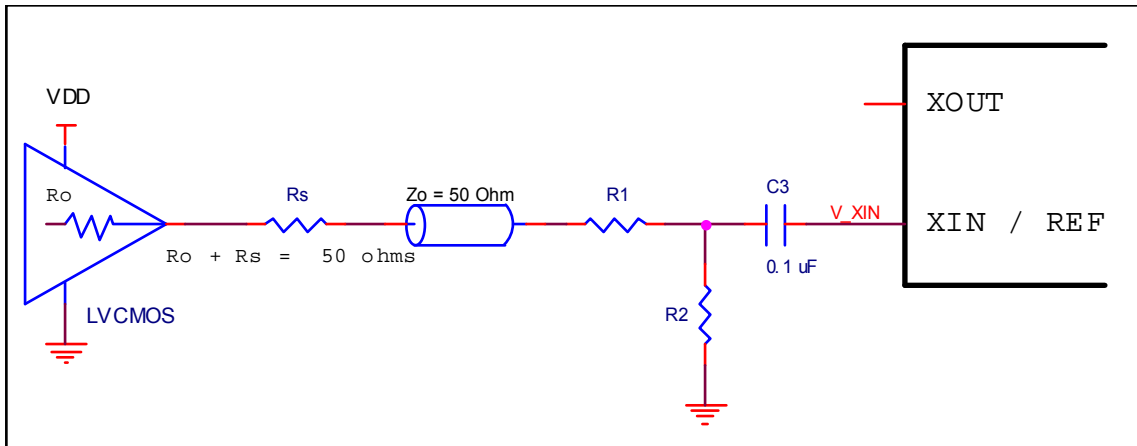

General Diagram for LVC MOS Driver to XTAL Input Interface

Table 24 Nominal Voltage Divider Values vs LVC MOS VDD for XIN shows resistor values that ensure the maximum drive level for the XIN/REF port is not exceeded for all combinations of 5% tolerance on the driver VDD, the VersaClock VDDA and 5% resistor tolerances. The values of the resistors can be

adjusted to reduce the loading for slower and weaker LVC MOS driver by increasing the voltage divider attenuation as long as the minimum drive level is maintained over all tolerances. To assist this assessment, the total load on the driver is included in the table.

Table 24: Nominal Voltage Divider Values vs LVC MOS VDD for XIN

LVC MOS Driver VDD	R_o+R_s	R1	R2	V_XIN (peak)	$R_o+R_s+R_1+R_2$
3.3	50.0	130	75	0.97	255
2.5	50.0	100	100	1.00	250
1.8	50.0	62	130	0.97	242

LVPECL Driver

Figure General Diagram for LVPECL Driver to XTAL Input Interface shows an example of the interface diagram for a +3.3V LVPECL driver. This is a standard LVPECL termination with one side of the driver feeding the XIN/REF input. It is recommended that all components in the schematics be placed in the layout; though some components might not be

used, they can be utilized for debugging purposes. The datasheet specifications are characterized and guaranteed by using a quartz crystal as the input. If the driver is 2.5V LVPECL, the only change necessary is to use the appropriate value of R3.

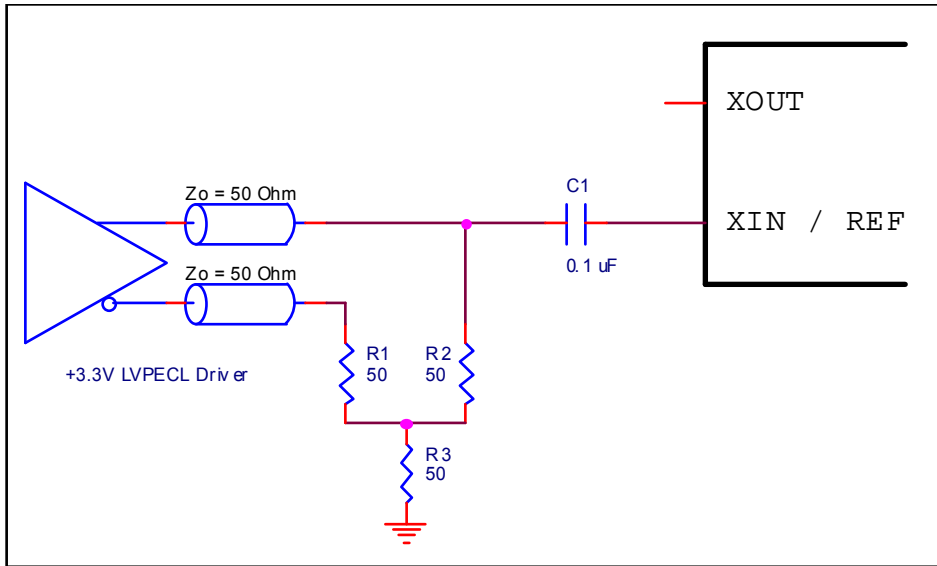

Table 25 Nominal Voltage Divider Values vs Driver VDD shows resistor values that ensure the maximum drive level for the CLKIN port is not exceeded for all combinations of 5% tolerance on the driver VDD, the VersaClock Vddo_0 and 5% resistor tolerances. The values of the resistors can be

adjusted to reduce the loading for slower and weaker LVCMOS driver by increasing the impedance of the R1-R2 divider. To assist this assessment, the total load on the driver is included in the table.

Table 25: Nominal Voltage Divider Values vs Driver VDD

LVCMOS Driver VDD	Ro+Rs	R1	R2	Vrx (peak)	Ro+Rs+R1+R2
3.3	50.0	130	75	0.97	255
2.5	50.0	100	100	1.00	250
1.8	50.0	62	130	0.97	242

LVDS Driver Termination

For a general LVDS interface, the recommended value for the termination impedance (Z_T) is between 90Ω and 132Ω . The actual value should be selected to match the differential impedance (Z_0) of your transmission line. A typical point-to-point LVDS design uses a 100Ω parallel resistor at the receiver and a 100Ω differential transmission-line environment. In order to avoid any transmission-line reflection issues, the components should be surface mounted and must be placed as close to the receiver as possible. The standard termination schematic as shown in figure *Standard Termination* or the termination of figure *Optional Termination* can be used, which uses a center tap capacitance to help filter

common mode noise. The capacitor value should be approximately 50pF . In addition, since these outputs are LVDS compatible, the input receiver's amplitude and common-mode input range should be verified for compatibility with the IDT LVDS output. If using a non-standard termination, it is recommended to contact IDT and confirm that the termination will function as intended. For example, the LVDS outputs cannot be AC coupled by placing capacitors between the LVDS outputs and the 100 ohm shunt load. If AC coupling is required, the coupling caps must be placed between the 100 ohm shunt termination and the receiver. In this manner the termination of the LVDS output remains DC coupled

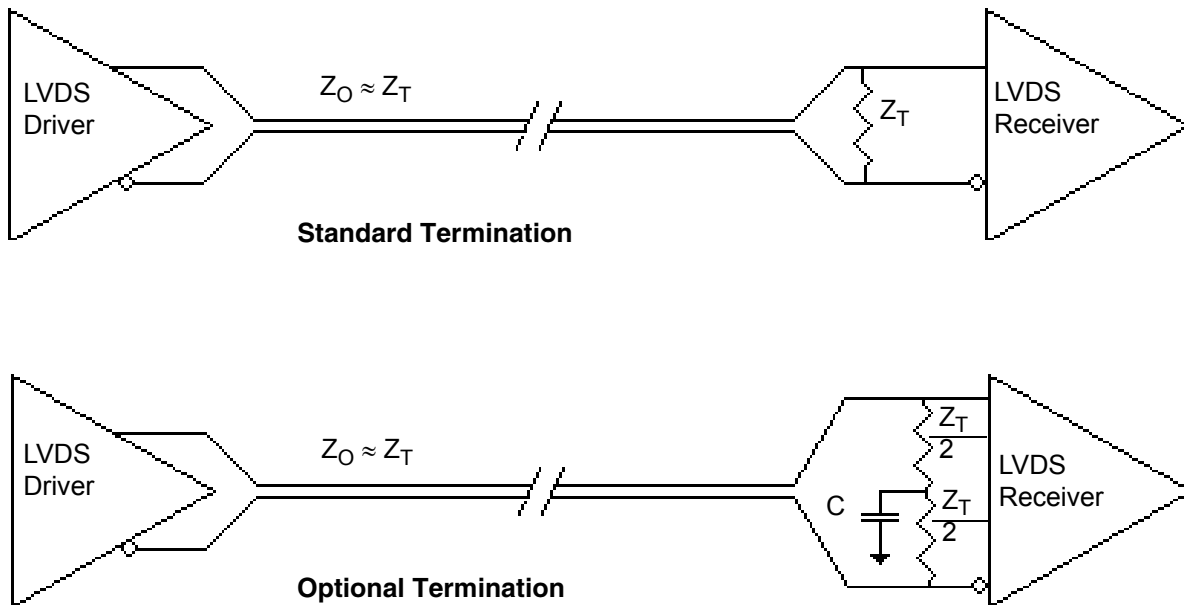

PCI Express Application Note

PCI Express jitter analysis methodology models the system response to reference clock jitter. The block diagram below shows the most frequently used Common Clock Architecture in which a copy of the reference clock is provided to both ends of the PCI Express Link. In the jitter analysis, the transmit (Tx) and receive (Rx) serdes PLLs are modeled as well as the phase interpolator in the receiver. These transfer functions are called H1, H2, and H3 respectively. The overall system transfer function at the receiver is:

$$H_t(s) = H_3(s) \times [H_1(s) - H_2(s)]$$

The jitter spectrum seen by the receiver is the result of applying this system transfer function to the clock spectrum X(s) and is:

$$Y(s) = X(s) \times H_3(s) \times [H_1(s) - H_2(s)]$$

In order to generate time domain jitter numbers, an inverse Fourier Transform is performed on $X(s) \cdot H_3(s) \cdot [H_1(s) - H_2(s)]$.

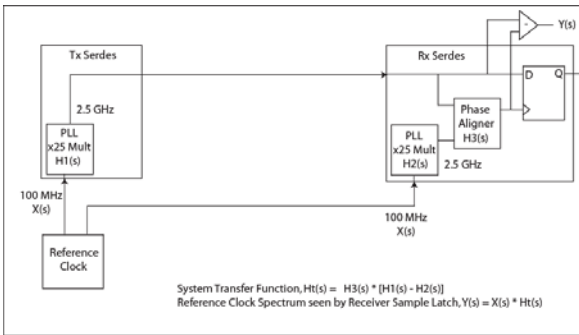

PCI Express Common Clock Architecture

For PCI Express Gen 1, one transfer function is defined and the evaluation is performed over the entire spectrum: DC to Nyquist (e.g. for a 100MHz reference clock: 0Hz – 50MHz) and the jitter result is reported in peak-peak.

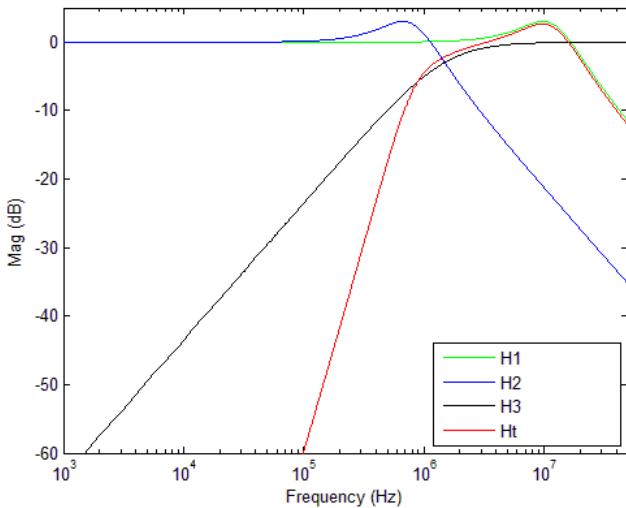

PCI Express Gen1 Magnitude of Transfer Function

For PCI Express Gen2, two transfer functions are defined with 2 evaluation ranges and the final jitter number is reported in

RMS. The two evaluation ranges for PCI Express Gen 2 are 10kHz – 1.5MHz (Low Band) and 1.5MHz – Nyquist (High Band). The plots show the individual transfer functions as well as the overall transfer function Ht.

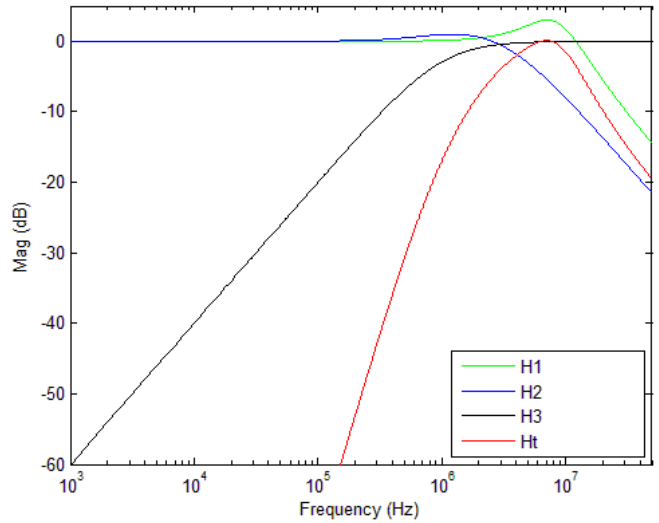

PCIe Gen2A Magnitude of Transfer Function

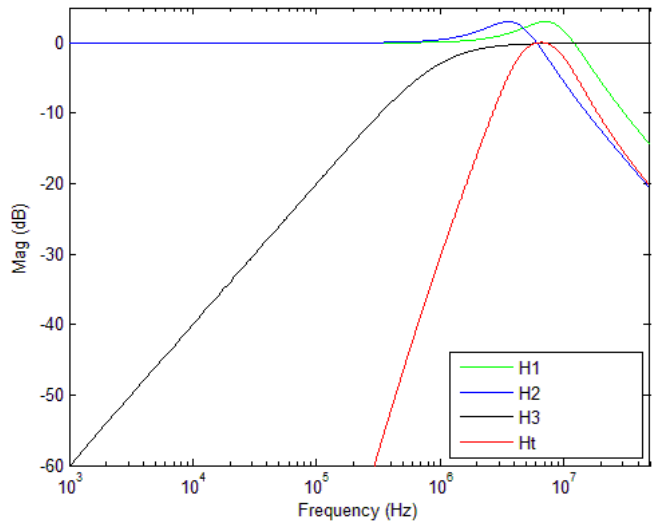

PCIe Gen2B Magnitude of Transfer Function

For PCI Express Gen 3, one transfer function is defined and the evaluation is performed over the entire spectrum. The transfer function parameters are different from Gen 1 and the jitter result is reported in RMS.

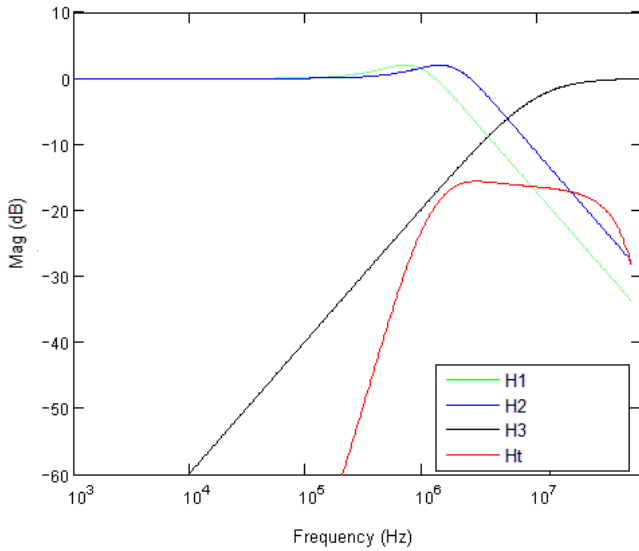

PCIe Gen3 Magnitude of Transfer Function

For a more thorough overview of PCI Express jitter analysis methodology, please refer to IDT Application Note PCI Express Reference Clock Requirements.

Marking Diagram

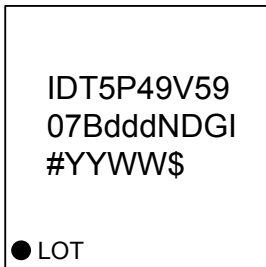

1. “ddd” denotes the dash code.
2. “G” denotes RoHS compliance.
3. “I” denotes industrial temperature.
4. “#” denotes the stepping code.
5. “YYWW” is the two last digits of the year and week that the part was assembled.
6. “\$” denotes mark code.
7. “LOT” denotes lot number.

Package Outline and Dimensions NDG40 (40-pin 5 x 5mm VFQFPN)

REVISIONS			
REV	DESCRIPTION	DATE	APPROVED
00	INITIAL RELEASE	5/17/16	JH

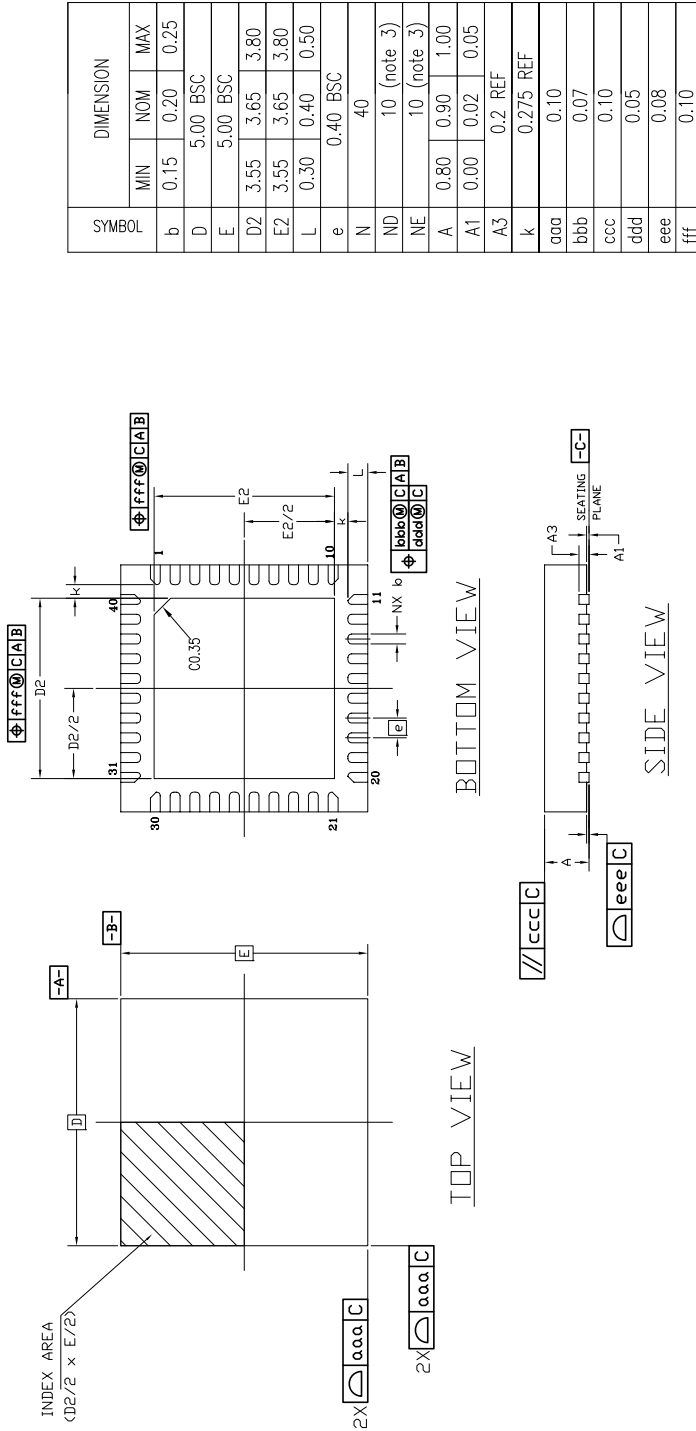

- NOTES:
1. ALL DIMENSIONING AND TOLERANCING CONFORM TO ANSI Y14.5M-1982
 2. ALL DIMENSIONS ARE IN MILLIMETERS.
 3. ND AND NE REFER TO THE NUMBER OF TERMINALS ON EACH D AND E SIDE RESPECTIVELY.

TOLERANCES UNLESS SPECIFIED	DECIMAL	ANGULAR	±1°
APPROVALS	DATE	TITLEND/NDG40 PACKAGE OUTLINE	
DRAWN	05/31/10	5.0 x 5.0 mm BODY, EPAD 3.65mm SQ.	
CHECKED		0.40 mm PITCH QFN	
SIZE	DRAWING No.	REV	
	C	PSC-4292-01	00
DO NOT SCALE DRAWING			SHEET 1 OF 2



Package Outline and Dimensions NDG40 (40-pin 5 x 5mm VFQFPN), cont.

REVISIONS		
REV	DESCRIPTION	DATE
00	INITIAL RELEASE	5/17/16
		JH

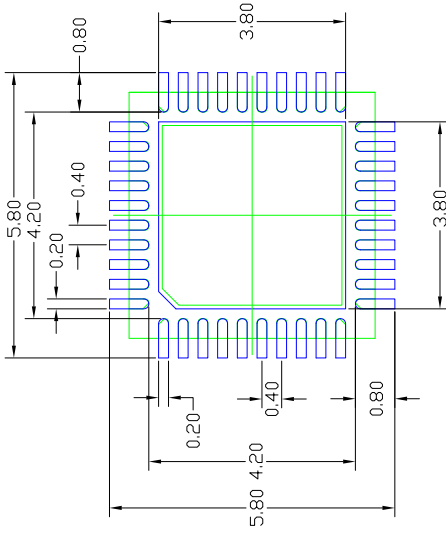

RECOMMENDED LAND PATTERN

NOTES:

1. ALL DIMENSIONS ARE IN mm. ANGLES IN DEGREES.
2. TOP DOWN VIEW AS VIEWED ON PCB.
3. COMPONENT OUTLINE SHOWS FOR REFERENCE IN GREEN.
4. LAND PATTERN IN BLUE. NSMD PATTERN ASSUMED.
5. LAND PATTERN RECOMMENDATION PER IPC-7351B GENERIC REQUIREMENT FOR SURFACE MOUNT DESIGN AND LAND PATTERN.

TOLERANCES UNLESS SPECIFIED	6024 SILVER CREEK VALLEY ROAD, SAN JOSE, CA 95138 PHONE: (408) 284-8200 FAX: (408) 284-3572
DECIMAL ±1°	IDT™ www.IDT.com
XX±.05	TITLE/NDG40 PACKAGE OUTLINE
XXX±.030	5.0 x 5.0 mm BODY, EPAD 3.65mm SQ. 0.40 mm PITCH QFN
APPROVALS	DATE
DRAWN 7/10	05/31/10
CHECKED	
SIZE	DRAWING No.
C	PSC-4292-01
REV	00
DO NOT SCALE DRAWING	
SHEET 2 OF 2	

Ordering Information

Part / Order Number	Marking	Shipping Packaging	Package	Temperature
5P49V5907BdddNDGI	see page 26	Trays	40-pin VFQFPN	-40° to +85°C
5P49V5907BdddNDGI8		Tape and Reel	40-pin VFQFPN	-40° to +85°C

“ddd” denotes the dash code.

“G” after the two-letter package code denotes Pb-Free configuration, RoHS compliant.

Revision History

Date	Description of Change
March 3, 2017	Updated POD drawings.
February 24, 2017	1. Added “Output Alignment” section. 2. Update “Output Divides” section

IMPORTANT NOTICE AND DISCLAIMER

RENESAS ELECTRONICS CORPORATION AND ITS SUBSIDIARIES (“RENESAS”) PROVIDES TECHNICAL SPECIFICATIONS AND RELIABILITY DATA (INCLUDING DATASHEETS), DESIGN RESOURCES (INCLUDING REFERENCE DESIGNS), APPLICATION OR OTHER DESIGN ADVICE, WEB TOOLS, SAFETY INFORMATION, AND OTHER RESOURCES “AS IS” AND WITH ALL FAULTS, AND DISCLAIMS ALL WARRANTIES, EXPRESS OR IMPLIED, INCLUDING, WITHOUT LIMITATION, ANY IMPLIED WARRANTIES OF MERCHANTABILITY, FITNESS FOR A PARTICULAR PURPOSE, OR NON-INFRINGEMENT OF THIRD-PARTY INTELLECTUAL PROPERTY RIGHTS.

These resources are intended for developers who are designing with Renesas products. You are solely responsible for (1) selecting the appropriate products for your application, (2) designing, validating, and testing your application, and (3) ensuring your application meets applicable standards, and any other safety, security, or other requirements. These resources are subject to change without notice. Renesas grants you permission to use these resources only to develop an application that uses Renesas products. Other reproduction or use of these resources is strictly prohibited. No license is granted to any other Renesas intellectual property or to any third-party intellectual property. Renesas disclaims responsibility for, and you will fully indemnify Renesas and its representatives against, any claims, damages, costs, losses, or liabilities arising from your use of these resources. Renesas' products are provided only subject to Renesas' Terms and Conditions of Sale or other applicable terms agreed to in writing. No use of any Renesas resources expands or otherwise alters any applicable warranties or warranty disclaimers for these products.

(Disclaimer Rev.1.01)

Corporate Headquarters

TOYOSU FORESIA, 3-2-24 Toyosu,
Koto-ku, Tokyo 135-0061, Japan
www.renesas.com

Trademarks

Renesas and the Renesas logo are trademarks of Renesas Electronics Corporation. All trademarks and registered trademarks are the property of their respective owners.

Contact Information

For further information on a product, technology, the most up-to-date version of a document, or your nearest sales office, please visit www.renesas.com/contact-us/.