

Description

The 5P49V6913 is a programmable clock generator intended for high performance consumer, networking, industrial, computing, and data-communications applications. Configurations may be stored in on-chip One-Time Programmable (OTP) memory or changed using I²C interface. This is IDTs fifth generation of programmable clock technology (VersaClock[®] 6).

The frequencies are generated from a single reference clock. The reference clock can come from one of the two redundant clock inputs. A glitchless manual switchover function allows one of the redundant clocks to be selected during normal operation.

Two select pins allow up to 4 different configurations to be programmed and accessible using processor GPIOs or bootstrapping. The different selections may be used for different operating modes (full function, partial function, partial power-down), regional standards (US, Japan, Europe) or system production margin testing.

The device may be configured to use one of two I²C addresses to allow multiple devices to be used in a system.

Pin Assignment

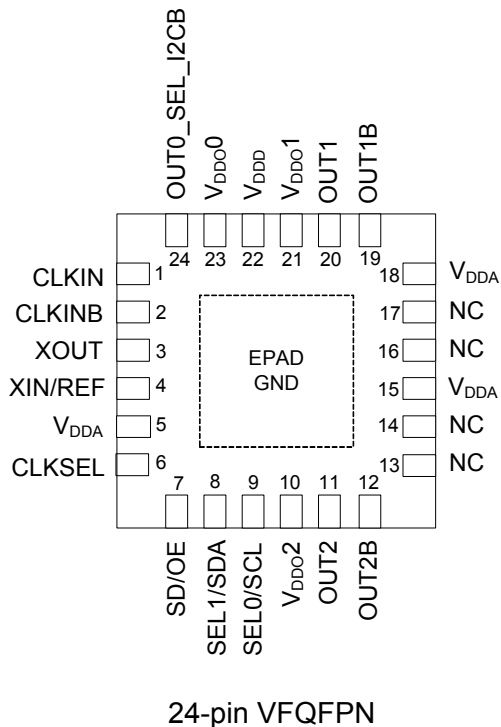

Features

- Generates up to two independent output frequencies
- High performance, low phase noise PLL, < 0.5ps RMS typical phase jitter on outputs:
 - PCIe Gen1, 2, 3 compliant clock capability
 - USB 3.0 compliant clock capability
 - 1GbE and 10GbE
- Two fractional output dividers (FODs)
- Independent Spread Spectrum capability on each output pair
- Four banks of internal non-volatile in-system programmable or factory programmable OTP memory
- I²C serial programming interface
- One reference LVCMOS output clock
- Two universal output pairs:
 - Each configurable as one differential output pair or two LVCMOS outputs
- I/O Standards:
 - Single-ended I/Os: 1.8V to 3.3V LVCMOS
 - Differential I/Os: LVPECL, LVDS and HCSL
- Input frequency ranges:
 - LVCMOS Reference Clock Input (XIN/REF) – 1MHz to 200MHz
 - LVDS, LVPECL, HCSL Differential Clock Input (CLKIN, CLKINB) – 1MHz to 350MHz
 - Crystal frequency range: 8MHz to 40MHz
- Output frequency ranges:
 - LVCMOS Clock Outputs – 1MHz to 200MHz
 - LVDS, LVPECL, HCSL Differential Clock Outputs – 1MHz to 350MHz
- Individually selectable output voltage (1.8V, 2.5V, 3.3V) for each output pair
- Redundant clock inputs with manual switchover
- Programmable loop bandwidth
- Programmable slew rate control
- Programmable crystal load capacitance
- Individual output enable/disable
- Power-down mode
- 1.8V, 2.5V or 3.3V core V_{DDO}, V_{DDA}
- Available in 24-VFQFPN 4 x 4 mm package
- -40° to +85°C industrial temperature operation

Functional Block Diagram

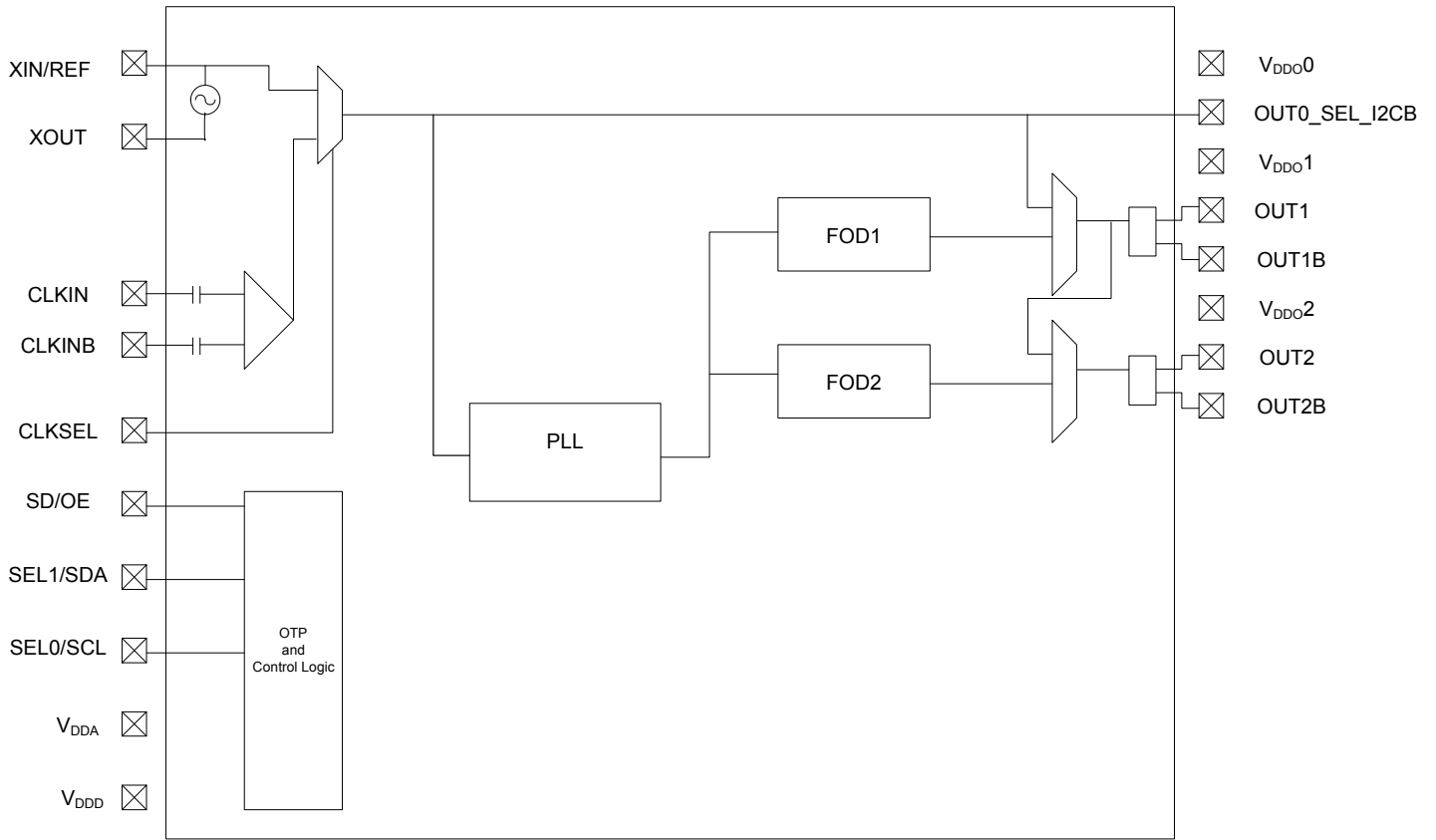

Applications

- Ethernet switch/router
- PCI Express 1.0/2.0/3.0
- Broadcast video/audio timing
- Multi-function printer
- Processor and FPGA clocking
- Any-frequency clock conversion
- MSAN/DSLAM/PON
- Fiber Channel, SAN
- Telecom line cards
- 1 GbE and 10 GbE

Table 1: Pin Descriptions

Number	Name	Type	Description
1	CLKIN	Input	Differential clock input. Weak 100kohms internal pull-down.
2	CLKINB	Input	Complementary differential clock input. Weak 100kohms internal pull-down.
3	XOUT	Input	Crystal Oscillator interface output.
4	XIN/REF	Input	Crystal Oscillator interface input, or single-ended LVCMOS clock input. Ensure that the input voltage is 1.2V max. Refer to the section "Overdriving the XIN/REF Interface".
5	VDDA	Power	Analog functions power supply pin. Connect to 1.8V to 3.3V. VDDA and VDDD should have the same voltage applied.
6	CLKSEL	Input	Pull-down Input clock select. Selects the active input reference source, when in Manual switchover mode. 0 = XIN/REF, XOUT (default) 1 = CLKIN, CLKINB CLKSEL Polarity can be changed by I2C programming as shown in Table 4.
7	SD/OE	Input	Enables/disables the outputs (OE) or powers down the chip (SD). The SH bit controls the configuration of the SD/OE pin. The SH bit needs to be high for SD/OE pin to be configured as SD. The SP bit (0x02) controls the polarity of the signal to be either active HIGH or LOW only when pin is configured as OE (Default is active LOW.) Weak internal pull down resistor. When configured as SD, device is shut down, differential outputs are driven high/low, and the single-ended LVCMOS outputs are driven low. When configured as OE, and outputs are disabled, the outputs can be selected to be tri-stated or driven high/low, depending on the programming bits as shown in the SD/OE Pin Function Truth table.
8	SEL1/SDA	Input	Configuration select pin, or I2C SDA input as selected by OUT0_SEL_I2CB. Weak internal pull down resistor.
9	SEL0/SCL	Input	Configuration select pin, or I2C SCL input as selected by OUT0_SEL_I2CB. Weak internal pull down resistor.
10	VDDO2	Power	Output power supply. Connect to 1.8 to 3.3V. Sets output voltage levels for OUT2/OUT2B.
11	OUT2	Output	Output Clock 2. Please refer to the Output Drivers section for more details.
12	OUT2B	Output	Complementary Output Clock 2. Please refer to the Output Drivers section for more details.
13	NC	—	No connect
14	NC	—	No connect
15	VDDA	Power	Analog functions power supply pin. Connect to 1.8V to 3.3V. VDDA and VDDD should have the same voltage applied.
16	NC	—	No connect
17	NC	—	No connect
18	VDDA	Power	Analog functions power supply pin. Connect to 1.8V to 3.3V. VDDA and VDDD should have the same voltage applied.
19	OUT1B	Output	Complementary Output Clock 1. Please refer to the Output Drivers section for more details.
20	OUT1	Output	Output Clock 1. Please refer to the Output Drivers section for more details.
21	VDDO1	Power	Output power supply. Connect to 1.8 to 3.3V. Sets output voltage levels for OUT1/OUT1B.
22	VDDD	Power	Digital functions power supply pin. Connect to 1.8 to 3.3V. VDDA and VDDB should have the same voltage applied.
23	VDDO0	Power	Power supply pin for OUT0_SEL_I2CB. Connect to 1.8 to 3.3V. Sets output voltage levels for OUT0.
24	OUT0_SELB_I2C	Input/Output	Latched input/LVCMOS Output. At power up, the voltage at the pin OUT0_SEL_I2CB is latched by the part and used to select the state of pins 8 and 9. If a weak pull up (10Kohms) is placed on OUT0_SEL_I2CB, pins 8 and 9 will be configured as hardware select pins, SEL1 and SEL0. If a weak pull down (10Kohms) is placed on OUT0_SEL_I2CB or it is left floating, pins 8 and 9 will act as the SDA and SCL pins of an I2C interface. After power up, the pin acts as a LVCMOS reference output.
ePAD	VEE	Power	Connect to ground pad.

PLL Features and Descriptions

Spread Spectrum

To help reduce electromagnetic interference (EMI), the 5P49V6913 supports spread spectrum modulation. The output clock frequencies can be modulated to spread energy across a broader range of frequencies, lowering system EMI. The 5P49V6913 implements spread spectrum using the Fractional-N output divide, to achieve controllable modulation rate and spreading magnitude. The Spread spectrum can be applied to any output clock, any clock frequency, and any spread amount from $\pm 0.25\%$ to $\pm 2.5\%$ center spread and -0.5% to -5% down spread.

Table 2: Loop Filter

PLL loop bandwidth range depends on the input reference frequency (Fref) and can be set between the loop bandwidth range as shown in the table below.

Input Reference Frequency—Fref (MHz)	Loop Bandwidth Min (kHz)	Loop Bandwidth Max (kHz)
5	40	126
350	300	1000

Table 3: Configuration Table

This table shows the SEL1, SEL0 settings to select the configuration stored in OTP. Four configurations can be stored in OTP. These can be factory programmed or user programmed.

OUT0_SEL_I2CB @ POR	SEL1	SEL0	I ² C Access	REG0:7	Config
1	0	0	No	0	0
1	0	1	No	0	1
1	1	0	No	0	2
1	1	1	No	0	3
0	X	X	Yes	1	I2C defaults
0	X	X	Yes	0	0

At power up time, the SEL0 and SEL1 pins must be tied to either the VDDD/VDDA power supply so that they ramp with that supply or are tied low (this is the same as floating the pins). This will cause the register configuration to be loaded that is selected according to Table 3 above. Providing that OUT0_SEL_I2CB was 1 at POR and OTP register 0:7=0, after the first 10mS of operation the levels of the SELx pins can be changed, either to low or to the same level as VDDD/VDDA. The SELx pins must be driven with a digital signal of < 300nS Rise/Fall time and only a single pin can be changed at a time. After a pin level change, the device must not be interrupted for at least 1ms so that the new values have time to load and take effect.

If OUT0_SEL_I2CB was 0 at POR, alternate configurations can only be loaded via the I2C interface.

Table 4: Input Clock Select

Input clock select. Selects the active input reference source in manual switchover mode.

0 = XIN/REF, XOUT (default)

1 = CLKIN, CLKINB

CLKSEL Polarity can be changed by I²C programming as shown in Table 4.

PRIMSRC	CLKSEL	Source
0	0	XIN/REF
0	1	CLKIN, CLKINB
1	0	CLKIN, CLKINB
1	1	XIN/REF

PRIMSRC is bit 1 of Register 0x13.

Reference Clock Input Pins and Selection

The 5P49V6913 supports up to two clock inputs. One input supports a crystal between XIN and XOUT. XIN can also be driven from a single ended reference clock. XIN can accept small amplitude signals like from TCXO or one channel of a differential clock.

The second clock input (CLKIN, CLKINB) is a fully differential input that only accepts a reference clock. The differential input accepts differential clocks from all the differential logic types and can also be driven from a single ended clock on one of the input pins.

The CLKSEL pin selects the input clock between either XTAL/REF or (CLKIN, CLKINB).

Either clock input can be set as the primary clock. The primary clock designation is to establish which is the main reference clock to the PLL. The non-primary clock is designated as the secondary clock in case the primary clock goes absent and a backup is needed. See the previous page for more details about primary versus secondary clock operation.

The two external reference clocks can be manually selected using the CLKSEL pin. The SM bits must be set to "0x" for manual switchover which is detailed in Manual Switchover Mode section.

Crystal Input (XIN/REF)

The crystal used should be a fundamental mode quartz crystal; overtone crystals should not be used.

A crystal manufacturer will calibrate its crystals to the nominal frequency with a certain load capacitance value. When the oscillator load capacitance matches the crystal load capacitance, the oscillation frequency will be accurate. When the oscillator load capacitance is lower than the crystal load capacitance, the oscillation frequency will be higher than nominal and vice versa so for an accurate oscillation frequency you need to make sure to match the oscillator load capacitance with the crystal load capacitance.

To set the oscillator load capacitance there are two tuning capacitors in the IC, one at XIN and one at XOUT. They can be adjusted independently but commonly the same value is used for both capacitors. The value of each capacitor is composed of a fixed capacitance amount plus a variable capacitance amount set with the XTAL[5:0] register. Adjustment of the crystal tuning capacitors allows for maximum flexibility to accommodate crystals from various manufacturers. The range of tuning capacitor values available are in accordance with the following table.

XTAL[5:0] Tuning Capacitor Characteristics

Parameter	Bits	Step (pF)	Min (pF)	Max (pF)
XTAL	6	0.5	9	25

The capacitance at each crystal pin inside the chip starts at 9pF with setting 000000b and can be increased up to 25pF with setting 111111b. The step per bit is 0.5pF.

You can write the following equation for this capacitance:

$$C_i = 9\text{pF} + 0.5\text{pF} \times \text{XTAL}[5:0]$$

The PCB where the IC and the crystal will be assembled adds some stray capacitance to each crystal pin and more capacitance can be added to each crystal pin with additional external capacitors.

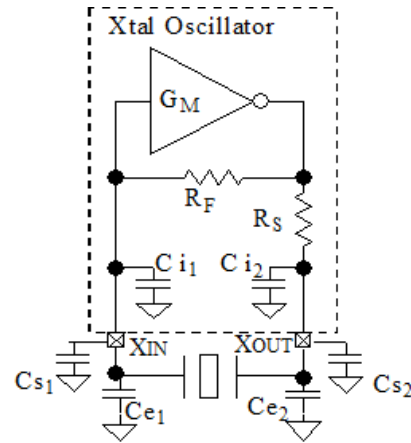

You can write the following equations for the total capacitance at each crystal pin:

$$C_{XIN} = C_{i1} + C_{s1} + C_{e1}$$

$$C_{XOUT} = C_{i2} + C_{s2} + C_{e2}$$

C_{i1} and C_{i2} are the internal, tunable capacitors. C_{s1} and C_{s2} are stray capacitances at each crystal pin and typical values are between 1pF and 3pF.

C_{e1} and C_{e2} are additional external capacitors that can be added to increase the crystal load capacitance beyond the tuning range of the internal capacitors. However, increasing the load capacitance reduces the oscillator gain so please consult the factory when adding C_{e1} and/or C_{e2} to avoid crystal startup issues. C_{e1} and C_{e2} can also be used to adjust for unpredictable stray capacitance in the PCB.

The final load capacitance of the crystal:

$$CL = C_{XIN} \times C_{XOUT} / (C_{XIN} + C_{XOUT})$$

For most cases it is recommended to set the value for capacitors the same at each crystal pin:

$$C_{XIN} = C_{XOUT} = C_x \rightarrow CL = C_x / 2$$

The complete formula when the capacitance at both crystal pins is the same:

$$CL = (9\text{pF} + 0.5\text{pF} \times \text{XTAL}[5:0] + C_s + C_e) / 2$$

Example 1: The crystal load capacitance is specified as 8pF and the stray capacitance at each crystal pin is $C_s=1.5\text{pF}$. Assuming equal capacitance value at XIN and XOUT, the equation is as follows:

$$8\text{pF} = (9\text{pF} + 0.5\text{pF} \times \text{XTAL}[5:0] + 1.5\text{pF}) / 2 \rightarrow$$

$$0.5\text{pF} \times \text{XTAL}[5:0] = 5.5\text{pF} \rightarrow \text{XTAL}[5:0] = 11 \text{ (decimal)}$$

Example 2: The crystal load capacitance is specified as 12pF and the stray capacitance C_s is unknown. Footprints for external capacitors C_e are added and a worst case C_s of 5pF is used. For now we use $C_s + C_e = 5\text{pF}$ and the right value for C_e can be determined later to make 5pF together with C_s .

$$12\text{pF} = (9\text{pF} + 0.5\text{pF} \times \text{XTAL}[5:0] + 5\text{pF}) / 2 \rightarrow$$

$$\text{XTAL}[5:0] = 20 \text{ (decimal)}$$

Manual Switchover Mode

When SM[1:0] is “0x”, the redundant inputs are in manual switchover mode. In this mode, CLKSEL pin is used to switch between the primary and secondary clock sources. The primary and secondary clock source setting is determined by the PRIMSRC bit. During the switchover, no glitches will occur at the output of the device, although there may be frequency and phase drift, depending on the exact phase and frequency relationship between the primary and secondary clocks.

OTP Interface

The 5P49V6913 can also store its configuration in an internal OTP. The contents of the device's internal programming registers can be saved to the OTP by setting burn_start (W114[3]) to high and can be loaded back to the internal programming registers by setting usr_rd_start(W114[0]) to high.

To initiate a save or restore using I²C, only two bytes are transferred. The Device Address is issued with the read/write bit set to “0”, followed by the appropriate command code. The save or restore instruction executes after the STOP condition is issued by the Master, during which time the 5P49V6913 will not generate Acknowledge bits. The 5P49V6913 will acknowledge the instructions after it has completed execution of them. During that time, the I²C bus should be interpreted as busy by all other users of the bus.

On power-up of the 5P49V6913, an automatic restore is performed to load the OTP contents into the internal programming registers. The 5P49V6913 will be ready to accept a programming instruction once it acknowledges its 7-bit I²C address.

Availability of Primary and Secondary I²C addresses to allow programming for multiple devices in a system. The I²C slave address can be changed from the default 0xD4 to 0xD0 by programming the I2C_ADDR bit D0. *VersaClock 6 Programming Guide* provides detailed I²C programming guidelines and register map.

SD/OE Pin Function

The polarity of the SD/OE signal pin can be programmed to be either active HIGH or LOW with the SP bit (W16[1]). When SP is “0” (default), the pin becomes active LOW and when SP is “1”, the pin becomes active HIGH. The SD/OE pin can be configured as either to shutdown the PLL or to enable/disable the outputs. The SH bit controls the configuration of the SD/OE pin. The SH bit needs to be high for SD/OE pin to be configured as SD.

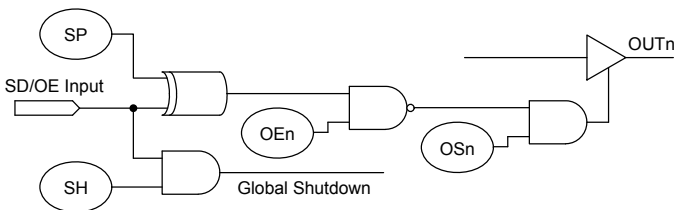

When configured as SD, device is shut down, differential outputs are driven High/Low, and the single-ended LVCMOS outputs are driven low. When configured as OE, and outputs are disabled, the outputs are driven high/low.

Table 5: SD/OE Pin Function Truth Table

SH bit	SP bit	OSn bit	OEn bit	SD/OE	OUTn
0	0	0	x	x	Tri-state ²
0	0	1	0	x	Output active
0	0	1	1	0	Output active
0	0	1	1	1	Output driven High Low
0	1	0	x	x	Tri-state ²
0	1	1	0	x	Output active
0	1	1	1	0	Output driven High Low
0	1	1	1	1	Output active
1	0	0	x	0	Tri-state ²
1	0	1	0	0	Output active
1	0	1	1	0	Output active
1	1	0	x	0	Tri-state ²
1	1	1	0	0	Output active
1	1	1	1	0	Output driven High Low
1	x	x	x	1	Output driven High Low ¹

Note 1 : Global Shutdown

Note 2 : Tri-state regardless of OEn bits

Output Divides

Each output divide block has a synchronizing POR pulse to provide startup alignment between outputs divides. This allows alignment of outputs for low skew performance. This low skew would also be realized between outputs that are both integer divides from the VCO frequency. This phase alignment works when using configuration with SEL1, SEL0. For I²C programming, I²C reset is required.

An output divide bypass mode (divide by 1) will also be provided, to allow multiple buffered reference outputs.

Each of the two output divides are comprised of a 12 bit integer counter, and a 24 bit fractional counter. The output divide can operate in integer divide only mode for improved performance, or utilize the fractional counters to generate a clock frequency accurate to 50 ppb.

Each of the output divides also have structures capable of independently generating spread spectrum modulation on the frequency output.

The Output Divide also has the capability to apply a spread modulation to the output frequency. Independent of output frequency, a triangle wave modulation between 30 and 63kHz may be generated.

For all outputs, there is a bypass mode, to allow the output to behave as a buffered copy of the input.

Output Skew

For outputs that share a common output divide value, there will be the ability to skew outputs by quadrature values to minimize interaction on the PCB. The skew on each output can be adjusted from 0 to 360 degrees. Skew is adjusted in units equal to 1/32 of the VCO period. So, for 100 MHz output and a 2800 MHz VCO, you can select how many 11.161pS units you want added to your skew (resulting in units of 0.402 degrees). For example, 0, 0.402, 0.804, 1.206, 1.408, and so on. The granularity of the skew adjustment is always dependent on the VCO period and the output period.

Output Drivers

The OUT1 and OUT2 clock outputs are provided with register-controlled output drivers. By selecting the output drive type in the appropriate register, any of these outputs can support LVCMOS, LVPECL, HCSL or LVDS logic levels

The operating voltage ranges of each output is determined by its independent output power pin (V_{DDO}) and thus each can have different output voltage levels. Output voltage levels of 2.5V or 3.3V are supported for differential HCSL, LVPECL operation, and 1.8V, 2.5V, or 3.3V are supported for LVCMOS and differential LVDS operation.

Each output may be enabled or disabled by register bits. When disabled an output will be in a logic 0 state as determined by the programming bit table shown on page 6.

LVCMOS Operation

When a given output is configured to provide LVCMOS levels, then both the OUTx and OUTxB outputs will toggle at the selected output frequency. All the previously described configuration and control apply equally to both outputs. Frequency, phase alignment, voltage levels and enable / disable status apply to both the OUTx and OUTxB pins. The OUTx and OUTxB outputs can be selected to be phase-aligned with each other or inverted relative to one another by register programming bits. Selection of phase-alignment may have negative effects on the phase noise performance of any part of the device due to increased simultaneous switching noise within the device.

Device Hardware Configuration

The 5P49V6913 supports an internal One-Time Programmable (OTP) memory that can be pre-programmed at the factory with up to 4 complete device configurations.

These configurations can be over-written using the serial interface once reset is complete. Any configuration written via the programming interface needs to be re-written after any power cycle or reset. Please contact IDT if a specific factory-programmed configuration is desired.

Device Start-up & Reset Behavior

The 5P49V6913 has an internal power-up reset (POR) circuit. The POR circuit will remain active for a maximum of 10ms after device power-up.

Upon internal POR circuit expiring, the device will exit reset and begin self-configuration.

The device will load internal registers according to [Table 3](#).

Once the full configuration has been loaded, the device will respond to accesses on the serial port and will attempt to lock the PLL to the selected source and begin operation.

I²C Mode Operation

The device acts as a slave device on the I²C bus using one of the two I²C addresses (0xD0 or 0xD4) to allow multiple devices to be used in the system. The interface accepts byte-oriented block write and block read operations. Two address bytes specify the register address of the byte position of the first register to write or read. Data bytes (registers) are accessed in sequential order from the lowest to the highest byte (most significant bit first). Read and write block transfers can be stopped after any complete byte transfer. During a write operation, data will not be moved into the registers until the STOP bit is received, at which point, all data received in the block write will be written simultaneously.

For full electrical I²C compliance, it is recommended to use external pull-up resistors for SDATA and SCLK. The internal pull-down resistors have a size of 100kΩ typical.

Current Read

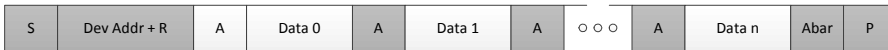

Sequential Read

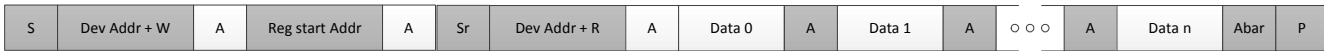

Sequential Write



- from master to slave
- from slave to master
- S = start
- Sr = repeated start
- A = acknowledge
- Abar = none acknowledge
- P = stop

I²C Slave Read and Write Cycle Sequencing

Table 6: I²C Bus DC Characteristics

Symbol	Parameter	Conditions	Min	Typ	Max	Unit
V _{IH}	Input HIGH Level	For SEL1/SDA pin and SEL0/SCL pin.	0.7xV _{DDD}		5.5 ²	V
V _{IL}	Input LOW Level	For SEL1/SDA pin and SEL0/SCL pin.	GND-0.3		0.3xV _{DDD}	V
V _{HYS}	Hysteresis of Inputs		0.05xV _{DDD}			V
I _{IN}	Input Leakage Current		-1		30	μA
V _{OL}	Output LOW Voltage	I _{OL} = 3 mA			0.4	V

Table 7: I²C Bus AC Characteristics

Symbol	Parameter	Min	Typ	Max	Unit
F _{SCLK}	Serial Clock Frequency (SCL)	10		400	kHz
t _{BUF}	Bus free time between STOP and START	1.3			μs
t _{SU:START}	Setup Time, START	0.6			μs
t _{HD:START}	Hold Time, START	0.6			μs
t _{SU:DATA}	Setup Time, data input (SDA)	0.1			μs
t _{HD:DATA}	Hold Time, data input (SDA) ¹	0			μs
t _{OVD}	Output data valid from clock			0.9	μs
C _B	Capacitive Load for Each Bus Line			400	pF
t _R	Rise Time, data and clock (SDA, SCL)	20 + 0.1xC _B		300	ns
t _F	Fall Time, data and clock (SDA, SCL)	20 + 0.1xC _B		300	ns
t _{HIGH}	HIGH Time, clock (SCL)	0.6			μs
t _{LOW}	LOW Time, clock (SCL)	1.3			μs
t _{SU:STOP}	Setup Time, STOP	0.6			μs

Note 1: A device must internally provide a hold time of at least 300 ns for the SDA signal (referred to the V_{IH}(MIN) of the SCL signal) to bridge the undefined region of the falling edge of SCL.

Note 2: I2C inputs are 5V tolerant.

Table 8: Absolute Maximum Ratings

Stresses above the ratings listed below can cause permanent damage to the 5P49V6913. These ratings, which are standard values for IDT commercially rated parts, are stress ratings only. Functional operation of the device at these or any other conditions above those indicated in the operational sections of the specifications is not implied. Exposure to absolute maximum rating conditions for extended periods can affect product reliability. Electrical parameters are guaranteed only over the recommended operating temperature range.

Item	Rating
Supply Voltage, V_{DDA} , V_{DDD} , V_{DDO}	3.465V
Inputs XIN/REF CLKIN, CLKINB Other inputs	0V to 1.2V voltage swing 0V to 1.2V voltage swing single-ended -0.5V to V_{DDD}
Outputs, V_{DDO} (LVCMOS)	-0.5V to $V_{DDO} + 0.5V$
Outputs, I_O (SDA)	10mA
Package Thermal Impedance, θ_{JA}	42°C/W (0 mps)
Package Thermal Impedance, θ_{JC}	41.8°C/W (0 mps)
Storage Temperature, T_{STG}	-65°C to 150°C
ESD Human Body Model	2000V
Junction Temperature	125°C

Table 9: Recommended Operation Conditions

Symbol	Parameter	Min	Typ	Max	Unit
V_{DDOX}	Power supply voltage for supporting 1.8V outputs	1.71	1.8	1.89	V
V_{DDOX}	Power supply voltage for supporting 2.5V outputs	2.375	2.5	2.625	V
V_{DDOX}	Power supply voltage for supporting 3.3V outputs	3.135	3.3	3.465	V
V_{DDD}	Power supply voltage for core logic functions	1.71		3.465	V
V_{DDA}	Analog power supply voltage. Use filtered analog power supply.	1.71		3.465	V
T_A	Operating temperature, ambient	-40		+85	°C
C_{LOAD_OUT}	Maximum load capacitance (3.3V LVCMOS only)			15	pF
F_{IN}	External reference crystal	1		40	MHz
	External reference clock CLKIN, CLKINB	5		350	
t_{PU}	Power up time for all V_{DDs} to reach minimum specified voltage (power ramps must be monotonic)	0.05		5	ms

Table 10: Input Capacitance, LVCMOS Output Impedance, and Internal Pull-down Resistance ($T_A = +25\text{ }^\circ\text{C}$)

Symbol	Parameter	Min	Typ	Max	Unit
C_{IN}	Input Capacitance (CLKIN, CLKINB, CLKSEL, SD/OE, SEL1/SDA, SEL0/SCL)		3	7	pF
Pull-down Resistor	CLKSEL, SD/OE, SEL1/SDA, SEL0/SCL, CLKIN, CLKINB, OUT0_SEL_I2CB	100		300	k Ω
R_{OUT}	LVCMOS Output Driver Impedance ($V_{DDO} = 1.8\text{V}, 2.5\text{V}, 3.3\text{V}$)		17		Ω
XIN/REF	Programmable input capacitance at XIN/REF	0		8	pF
XOUT	Programmable input capacitance at XOUT	0		8	pF

Table 11: Crystal Characteristics

Parameter	Test Conditions	Minimum	Typical	Maximum	Units
Mode of Oscillation		Fundamental			
Frequency		8	25	40	MHz
Equivalent Series Resistance (ESR)			10	100	Ω
Shunt Capacitance				7	pF
Load Capacitance (CL) @ ≤ 25 MHz		6	8	12	pF
Load Capacitance (CL) > 25 MHz to 40 MHz		6		8	pF
Maximum Crystal Drive Level				100	μW

Note: Typical crystal used is [FOX 603-25-150](#). For different reference crystal options please go to [www.foxonline.com](#).

Table 12: DC Electrical Characteristics

Symbol	Parameter	Test Conditions	Min	Typ	Max	Unit
I_{ddcore}^3	Core Supply Current	100 MHz on all outputs, 25 MHz REFCLK		30	34	mA
I_{ddox}	Output Buffer Supply Current	LVPECL, 350 MHz, 3.3V VDDOx		42	47	mA
		LVPECL, 350 MHz, 2.5V VDDOx		37	42	mA
		LVDS, 350 MHz, 3.3V VDDOx		18	21	mA
		LVDS, 350 MHz, 2.5V VDDOx		17	20	mA
		LVDS, 350 MHz, 1.8V VDDOx		16	19	mA
		HCSL, 250 MHz, 3.3V VDDOx, 2 pF load		29	33	mA
		HCSL, 250 MHz, 2.5V VDDOx, 2 pF load		28	33	mA
		LVCMOS, 50 MHz, 3.3V, VDDOx ^{1,2}		16	18	mA
		LVCMOS, 50 MHz, 2.5V, VDDOx ^{1,2}		14	16	mA
		LVCMOS, 50 MHz, 1.8V, VDDOx ^{1,2}		12	14	mA
		LVCMOS, 200 MHz, 3.3V VDDOx ¹		36	42	mA
LVCMOS, 200 MHz, 2.5V VDDOx ^{1,2}		27	32	mA		
LVCMOS, 200 MHz, 1.8V VDDOx ^{1,2}		16	19	mA		
I_{ddpd}	Power Down Current	SD asserted, I2C Programming		10	14	mA

1. Single CMOS driver active.

2. Measured into a 5" 50 Ohm trace with 2 pF load.

3. $I_{ddcore} = I_{ddA} + I_{ddD}$, no loads.

Table 13:Electrical Characteristics – Differential Clock Input Parameters^{1,2} (Supply Voltage V_{DDA} , V_{DDD} , V_{DDO0} = 3.3V \pm 5%, 2.5V \pm 5%, 1.8V \pm 5%, T_A = -40°C to +85°C)

Symbol	Parameter	Test Conditions	Min	Typ	Max	Unit
V_{IH}	Input HIGH Voltage–CLKIN, CLKINB	Single-ended input	0.55		1.7	V
V_{IL}	Input LOW Voltage–CLKIN, CLKINB	Single-ended input	GND - 0.3		0.4	V
V_{SWING}	Input Amplitude - CLKIN, CLKINB	Peak to Peak value, single-ended	200		1200	mV
dv/dt	Input Slew Rate - CLKIN, CLKINB	Measured differentially	0.4		8	V/ns
I_{IL}	Input Leakage Low Current	V_{IN} = GND	-5		5	μ A
I_{IH}	Input Leakage High Current	V_{IN} = 1.7V			20	μ A
d_{TIN}	Input Duty Cycle	Measurement from differential waveform	45		55	%

1. Guaranteed by design and characterization, not 100% tested in production.
2. Slew rate measured through \pm 75mV window centered around differential zero.

Table 14:DC Electrical Characteristics for 3.3V LVCMOS (V_{DDO} = 3.3V \pm 5%, T_A = -40°C to +85°C)¹

Symbol	Parameter	Test Conditions	Min	Typ	Max	Unit
V_{OH}	Output HIGH Voltage	I_{OH} = -15mA	2.4		V_{DDO}	V
V_{OL}	Output LOW Voltage	I_{OL} = 15mA			0.4	V
I_{OZDD}	Output Leakage Current (OUT1~2)	Tri-state outputs, V_{DDO} = 3.465V			5	μ A
I_{OZDD}	Output Leakage Current (OUT0)	Tri-state outputs, V_{DDO} = 3.465V			30	μ A
V_{IH}	Input HIGH Voltage	Single-ended inputs - CLKSEL, SD/OE	0.7xVDDD		$V_{DDD} + 0.3$	V
V_{IL}	Input LOW Voltage	Single-ended inputs - CLKSEL, SD/OE	GND - 0.3		0.3xVDDD	V
V_{IH}	Input HIGH Voltage	Single-ended input OUT0_SEL_I2CB	2		$V_{DDO0} + 0.3$	V
V_{IL}	Input LOW Voltage	Single-ended input OUT0_SEL_I2CB	GND - 0.3		0.4	V
V_{IH}	Input HIGH Voltage	Single-ended input - XIN/REF	0.8		1.2	V
V_{IL}	Input LOW Voltage	Single-ended input - XIN/REF	GND - 0.3		0.4	V
TR/TF	Input Rise/Fall Time	CLKSEL, SD/OE, SEL1SDA, SEL0/SCL			300	ns

1. See “Recommended Operating Conditions” table.

Table 15:DC Electrical Characteristics for 2.5V LVCMOS ($V_{DDO} = 2.5V \pm 5\%$, $T_A = -40^\circ\text{C}$ to $+85^\circ\text{C}$)

Symbol	Parameter	Test Conditions	Min	Typ	Max	Unit
VOH	Output HIGH Voltage	IOH = -12mA	0.7xVDDO			V
VOL	Output LOW Voltage	IOL = 12mA			0.4	V
IOZDD	Output Leakage Current (OUT1~2)	Tri-state outputs, VDDO = 2.625V			5	μA
IOZDD	Output Leakage Current (OUT0)	Tri-state outputs, VDDO = 3.465V			30	μA
VIH	Input HIGH Voltage	Single-ended inputs - CLKSEL, SD/OE	0.7xVDDD		VDDD + 0.3	V
VIL	Input LOW Voltage	Single-ended inputs - CLKSEL, SD/OE	GND - 0.3		0.3xVDDD	V
VIH	Input HIGH Voltage	Single-ended input OUT0_SEL_I2CB	1.7		VDDO0 + 0.3	V
VIL	Input LOW Voltage	Single-ended input OUT0_SEL_I2CB	GND - 0.3		0.4	V
VIH	Input HIGH Voltage	Single-ended input - XIN/REF	0.8		1.2	V
VIL	Input LOW Voltage	Single-ended input - XIN/REF	GND - 0.3		0.4	V
TR/TF	Input Rise/Fall Time	CLKSEL, SD/OE, SEL1SDA, SEL0/SCL			300	ns

Table 16:DC Electrical Characteristics for 1.8V LVCMOS ($V_{DDO} = 1.8V \pm 5\%$, $T_A = -40^\circ\text{C}$ to $+85^\circ\text{C}$)

Symbol	Parameter	Test Conditions	Min	Typ	Max	Unit
VOH	Output HIGH Voltage	IOH = -8mA	0.7 xVDDO		VDDO	V
VOL	Output LOW Voltage	IOL = 8mA			0.25 x VDDO	V
IOZDD	Output Leakage Current (OUT1~2)	Tri-state outputs, VDDO = 3.465V			5	μA
IOZDD	Output Leakage Current (OUT0)	Tri-state outputs, VDDO = 3.465V			30	μA
VIH	Input HIGH Voltage	Single-ended inputs - CLKSEL, SD/OE	0.7 * VDDD		VDDD + 0.3	V
VIL	Input LOW Voltage	Single-ended inputs - CLKSEL, SD/OE	GND - 0.3		0.3* VDDD	V
VIH	Input HIGH Voltage	Single-ended input OUT0_SEL_I2CB	0.65 * VDDO0		VDDO0 + 0.3	V
VIL	Input LOW Voltage	Single-ended input OUT0_SEL_I2CB	GND - 0.3		0.4	V
VIH	Input HIGH Voltage	Single-ended input - XIN/REF	0.8		1.2	V
VIL	Input LOW Voltage	Single-ended input - XIN/REF	GND - 0.3		0.4	V
TR/TF	Input Rise/Fall Time	CLKSEL, SD/OE, SEL1SDA, SEL0/SCL			300	ns

Table 17:DC Electrical Characteristics for LVDS ($V_{DDO} = 3.3V \pm 5\%$ or $2.5V \pm 5\%$, $T_A = -40^\circ\text{C}$ to $+85^\circ\text{C}$)

Symbol	Parameter	Min	Typ	Max	Unit
$V_{OT}(+)$	Differential Output Voltage for the TRUE binary state	247		454	mV
$V_{OT}(-)$	Differential Output Voltage for the FALSE binary state	-247		-454	mV
ΔV_{OT}	Change in V_{OT} between Complimentary Output States			50	mV
V_{OS}	Output Common Mode Voltage (Offset Voltage)	1.125	1.25	1.375	V
ΔV_{OS}	Change in V_{OS} between Complimentary Output States			50	mV
I_{OS}	Outputs Short Circuit Current, V_{OUT+} or $V_{OUT-} = 0V$ or V_{DDO}		9	24	mA
I_{OSD}	Differential Outputs Short Circuit Current, $V_{OUT+} = V_{OUT-}$		6	12	mA

Table 18:DC Electrical Characteristics for LVDS ($V_{DDO} = 1.8V \pm 5\%$, $T_A = -40^\circ\text{C}$ to $+85^\circ\text{C}$)

Symbol	Parameter	Min	Typ	Max	Unit
$V_{OT}(+)$	Differential Output Voltage for the TRUE binary state	247		454	mV
$V_{OT}(-)$	Differential Output Voltage for the FALSE binary state	-247		-454	mV
ΔV_{OT}	Change in V_{OT} between Complimentary Output States			50	mV
V_{OS}	Output Common Mode Voltage (Offset Voltage)	0.8	0.875	0.95	V
ΔV_{OS}	Change in V_{OS} between Complimentary Output States			50	mV
I_{OS}	Outputs Short Circuit Current, V_{OUT+} or $V_{OUT-} = 0V$ or V_{DDO}		9	24	mA
I_{OSD}	Differential Outputs Short Circuit Current, $V_{OUT+} = V_{OUT-}$		6	12	mA

Table 19:DC Electrical Characteristics for LVPECL ($V_{DDO} = 3.3V \pm 5\%$ or $2.5V \pm 5\%$, $T_A = -40^\circ\text{C}$ to $+85^\circ\text{C}$)

Symbol	Parameter	Min	Typ	Max	Unit
V_{OH}	Output Voltage HIGH, terminated through 50Ω tied to $V_{DD} - 2V$	$V_{DDO} - 1.19$		$V_{DDO} - 0.69$	V
V_{OL}	Output Voltage LOW, terminated through 50Ω tied to $V_{DD} - 2V$	$V_{DDO} - 1.94$		$V_{DDO} - 1.4$	V
V_{SWING}	Peak-to-Peak Output Voltage Swing	0.55		0.993	V

Table 20: Electrical Characteristics – DIF 0.7V HCSL Differential Outputs ($V_{DDO} = 3.3V \pm 5\%$, $2.5V \pm 5\%$, $T_A = -40^\circ\text{C}$ to $+85^\circ\text{C}$)

Symbol	Parameter	Conditions	Min	Typ	Max	Units	Notes
dV/dt	Slew Rate	Scope averaging on	1		4	V/ns	1,2,3
Δ dV/dt	Slew Rate	Scope averaging on			20	%	1,2,3
VHIGH	Voltage High	Statistical measurement on single-ended signal using oscilloscope math function (Scope averaging ON)	660		850	mV	1,6,7
VLOW	Voltage Low		-150		150	mV	1,6
VMAX	Maximum Voltage	Measurement on single-ended signal using absolute value (Scope averaging off)			1150	mV	1
VMIN	Minimum Voltage		-300			mV	1
VSWING	Voltage Swing	Scope averaging off	300			mV	1,2,6
VCROSS	Crossing Voltage Value	Scope averaging off	250		550	mV	1,4,6
Δ VCROSS	Crossing Voltage variation	Scope averaging off			140	mV	1,5

Note 1: Guaranteed by design and characterization. Not 100% tested in production

Note 2: Measured from differential waveform.

Note 3: Slew rate is measured through the VSWING voltage range centered around differential 0V. This results in a +/-150mV window around differential 0V.

Note 4: VCROSS is defined as voltage where Clock = Clock# measured on a component test board and only applies to the differential rising edge (i.e. Clock rising and Clock# falling).

Note 5: the total variation of all VCROSS measurements in any particular system. Note that this is a subset of VCROSS min/max (VCROSS absolute) allowed. The intent is to limit VCROSS induced modulation by setting Δ VCROSS to be smaller than VCROSS absolute.

Note 6: Measured from single-ended waveform.

Note 7: Measured with scope averaging off, using statistics function. Variation is difference between min. and max.

Table 21: AC Timing Electrical Characteristics
 $(V_{DDO} = 3.3V+5\% \text{ or } 2.5V+5\% \text{ or } 1.8V \pm 5\%, TA = -40^{\circ}C \text{ to } +85^{\circ}C)$

(Spread Spectrum Generation = OFF)

Symbol	Parameter	Test Conditions	Min.	Typ.	Max.	Units
f _{IN} ¹	Input Frequency	Input frequency limit (XIN)	8		40	MHz
		Input frequency limit (CLKIN, CLKINB)	1		350	MHz
		Input frequency limit (REF)	1		200	
f _{OUT}	Output Frequency	Single ended clock output limit (LVCMOS)	1		200	MHz
		Differential clock output limit (LVPECL/LVDS/HCSL)	1		350	
f _{VCO}	VCO Frequency	VCO operating frequency range	2500		3000	MHz
f _{PFD}	PFD Frequency	PFD operating frequency range	1 ¹		150	MHz
f _{BW}	Loop Bandwidth	Input frequency = 25MHz	0.06		0.9	MHz
t ₂	Input Duty Cycle	Duty Cycle	45	50	55	%
t ₃ ⁵	Output Duty Cycle	Measured at VDD/2, all outputs except Reference output OUT0, VDDOX= 2.5V or 3.3V	45	50	55	%
		Measured at VDD/2, all outputs except Reference output OUT0, VDDOX= 1.8V	40	50	60	%
		Measured at VDD/2, Reference output OUT0 (5MHz - 120MHz) with 50% duty	40	50	60	%
		Measured at VDD/2, Reference output OUT0 (150.1MHz - 200MHz) with 50% duty	30	50	70	%
t ₄ ²	Slew Rate, SLEW[1:0] = 00	Single-ended 3.3V LVCMOS output clock rise and fall time, 20% to 80% of VDDO (Output Load = 5 pF) VDDOX=3.3V	1.0	2.2		V/ns
	Slew Rate, SLEW[1:0] = 01		1.2	2.3		
	Slew Rate, SLEW[1:0] = 10		1.3	2.4		
	Slew Rate, SLEW[1:0] = 11		1.7	2.7		
	Slew Rate, SLEW[1:0] = 00	Single-ended 2.5V LVCMOS output clock rise and fall time, 20% to 80% of VDDO (Output Load = 5 pF) VDDOX=2.5V	0.6	1.3		
	Slew Rate, SLEW[1:0] = 01		0.7	1.4		
	Slew Rate, SLEW[1:0] = 10		0.6	1.4		
	Slew Rate, SLEW[1:0] = 11		1.0	1.7		
	Slew Rate, SLEW[1:0] = 00	Single-ended 1.8V LVCMOS output clock rise and fall time, 20% to 80% of VDDO (Output Load = 5 pF) VDDOX=1.8V	0.3	0.7		
	Slew Rate, SLEW[1:0] = 01		0.4	0.8		
	Slew Rate, SLEW[1:0] = 10		0.4	0.9		
	Slew Rate, SLEW[1:0] = 11		0.7	1.2		
t ₅	Rise Times	LVDS, 20% to 80%		300		ps
	Fall Times	LVDS, 80% to 20%		300		
	Rise Times	LVPECL, 20% to 80%		400		
	Fall Times	LVPECL, 80% to 20%		400		

t6	Output Clock Jitter with multiple output frequencies switching 25 MHz Crystal Input OUT0=25MHz - LVCMOS OUT1=100MHz - HCSL OUT2=125MHz - LVDS	Crystal Reference Output, Cycle-to-Cycle Jitter (Absolute Value), LVCMOS 3.3V±5%, -40°C ~ +90°C	5	30	ps
		PLL Output Cycle-to-Cycle Jitter (Absolute Value), all differential outputs 3.3V±5%, -40°C ~ +90°C	20	35	ps
		Crystal Reference Output, Period Jitter, LVCMOS - 3.3V±5%, -40°C ~ +90°C	28	40	ps
		PLL Output Period Jitter, all differential outputs, 3.3V±5%, -40°C ~ +90°C	4	30	ps
		RMS Phase Jitter (12kHz to 5MHz integration range) reference clock (OUT0), 25 MHz LVCMOS outputs (1.8 to 3.3V nominal output voltage).	0.3		ps
		RMS Phase Jitter (12kHz to 20MHz integration range) differential output, VDDO = 3.465V, 25MHz crystal, 125MHz output frequency	0.5	0.8	ps
t7	Output Skew	Skew between the same frequencies, with outputs using the same driver format and phase delay set to 0 ns.	75		ps
t8 ³	Startup Time	PLL lock time from power-up, measured after all VDD's have raised above 90% of their target value.		10	ms
t9 ⁴	Startup Time	PLL lock time from shutdown mode	3	4	ms

1. Practical lower frequency is determined by loop filter settings.
2. A slew rate of 2.75V/ns or greater should be selected for output frequencies of 100MHz or higher.
3. Includes loading the configuration bits from EPROM to PLL registers. It does not include EPROM programming/write time.
4. Actual PLL lock time depends on the loop configuration.

Table 22:PCI Express Jitter Specifications ($V_{DDO} = 3.3V \pm 5\%$ or $2.5V \pm 5\%$, $T_A = -40^\circ C$ to $+85^\circ C$)

Symbol	Parameter	Conditions	Min	Typ	Max	PCIe Industry Specification	Units	Notes
t_j (PCIe Gen1)	Phase Jitter Peak-to-Peak	$f = 100MHz$, 25MHz Crystal Input Evaluation Band: 0Hz - Nyquist (clock frequency/2)		30		86	ps	1,4
$t_{REFCLK_HF_RMS}$ (PCIe Gen2)	Phase Jitter RMS	$f = 100MHz$, 25MHz Crystal Input High Band: 1.5MHz - Nyquist (clock frequency/2)		2.56		3.10	ps	2,4
$t_{REFCLK_LF_RMS}$ (PCIe Gen2)	Phase Jitter RMS	$f = 100MHz$, 25MHz Crystal Input Low Band: 10kHz - 1.5MHz		0.27		3.0	ps	2,4
t_{REFCLK_RMS} (PCIe Gen3)	Phase Jitter RMS	$f = 100MHz$, 25MHz Crystal Input Evaluation Band: 0Hz - Nyquist (clock frequency/2)		0.8		1.0	ps	3,4

Note: Electrical parameters are guaranteed over the specified ambient operating temperature range, which is established when the device is mounted in a test socket with maintained transverse airflow greater than 500 lfm. The device will meet specifications after thermal equilibrium has been reached under these conditions.

1. Peak-to-Peak jitter after applying system transfer function for the Common Clock Architecture. Maximum limit for PCI Express Gen 1.
2. RMS jitter after applying the two evaluation bands to the two transfer functions defined in the Common Clock Architecture and reporting the worst case results for each evaluation band. Maximum limit for PCI Express Generation 2 is 3.1ps RMS for $t_{REFCLK_HF_RMS}$ (High Band) and 3.0ps RMS for $t_{REFCLK_LF_RMS}$ (Low Band).
3. RMS jitter after applying system transfer function for the common clock architecture. This specification is based on the PCI_Express_Base_r3.0 10 Nov, 2010 specification, and is subject to change pending the final release version of the specification.
4. This parameter is guaranteed by characterization. Not tested in production.

Table 23:Jitter Specifications ^{1,2,3}

($V_{DDx} = 3.3V \pm 5\%$ or $2.5V \pm 5\%$, $T_A = -40^\circ C$ to $+85^\circ C$)

Parameter	Symbol	Test Condition	Min	Typ	Max	Unit
GbE Random Jitter (12 kHz–20 MHz) ⁴	J_{GbE}	Crystal in = 25 MHz, All CLK _n at 125 MHz ⁵	-	0.79	0.95	ps
GbE Random Jitter (1.875–20 MHz)	$R_{J_{GbE}}$	Crystal in = 25 MHz, All CLK _n at 125 MHz ⁵	-	0.32	0.5	ps
OC-12 Random Jitter (12 kHz–5 MHz)	J_{OC12}	CLKIN = 19.44 MHz, All CLK _n at 155.52 MHz ⁵	-	0.69	0.95	ps
PCI Express 1.1 Common Clocked		Total Jitter ⁶	-	9.1	12	ps
PCI Express 2.1 Common Clocked		RMS Jitter ⁶ , 10 kHz to 1.5MHz	-	0.1	0.3	ps
		RMS Jitter ⁶ , 1.5MHz to 50MHz	-	0.9	1.1	ps
PCI Express 3.0 Common Clocked		RMS Jitter ⁶	-	0.2	0.4	ps

Notes:

¹ All measurements with Spread Spectrum Off.

² For best jitter performance, keep the single ended clock input slew rates at more than 1.0 V/ns and the differential clock input slew rates more than 0.3 V/ns.

³ All jitter data in this table is based upon all output formats being differential. When single-ended outputs are used, there is the potential that the output jitter may increase due to the nature of single-ended outputs. If your configuration implements any single-ended output and any output is required to have jitter less than 3 ps rms, contact IDT for support to validate your configuration and ensure the best jitter performance. In many configurations, CMOS outputs have little to no effect upon jitter.

⁴ DJ for PCI and GbE is < 5 ps pp.

⁵ Output FOD in Integer mode.

⁶ All output clocks 100 MHz HCSL format. Jitter is from the PCIe jitter filter combination that produces the highest jitter. Jitter is measured with the Intel Clock Jitter Tool, Ver. 1.6.6.

Table 24: Spread Spectrum Generation Specifications

Symbol	Parameter	Description	Min	Typ	Max	Unit
f_{OUT}	Output Frequency	Output Frequency Range	5		300	MHz
f_{MOD}	Mod Frequency	Modulation Frequency	30 to 63			kHz
f_{SPREAD}	Spread Value	Amount of Spread Value (programmable) - Center Spread	$\pm 0.25\%$ to $\pm 2.5\%$			$\%f_{OUT}$
		Amount of Spread Value (programmable) - Down Spread	-0.5% to -5%			

Test Circuits and Loads

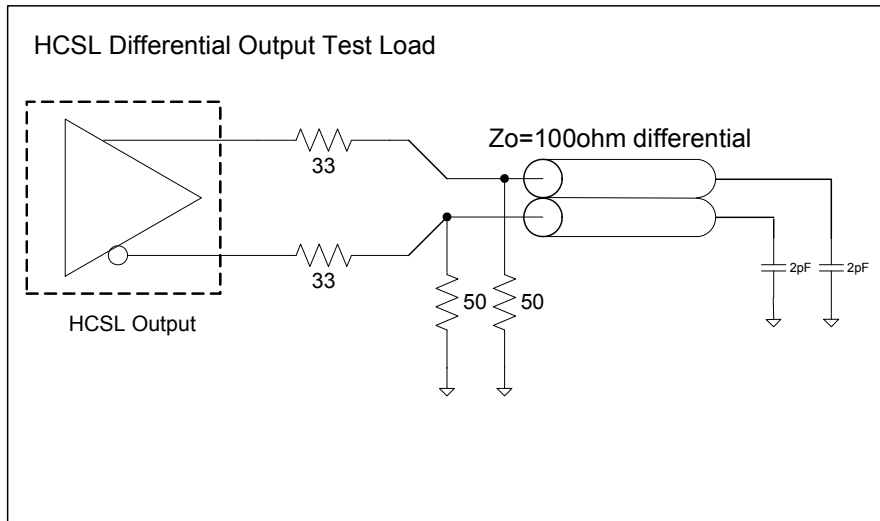
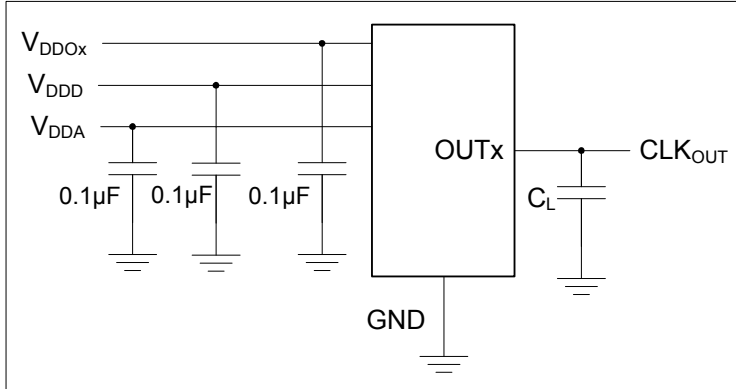

Test Circuits and Loads for Outputs

Typical Phase Noise at 100MHz (3.3V, 25°C)

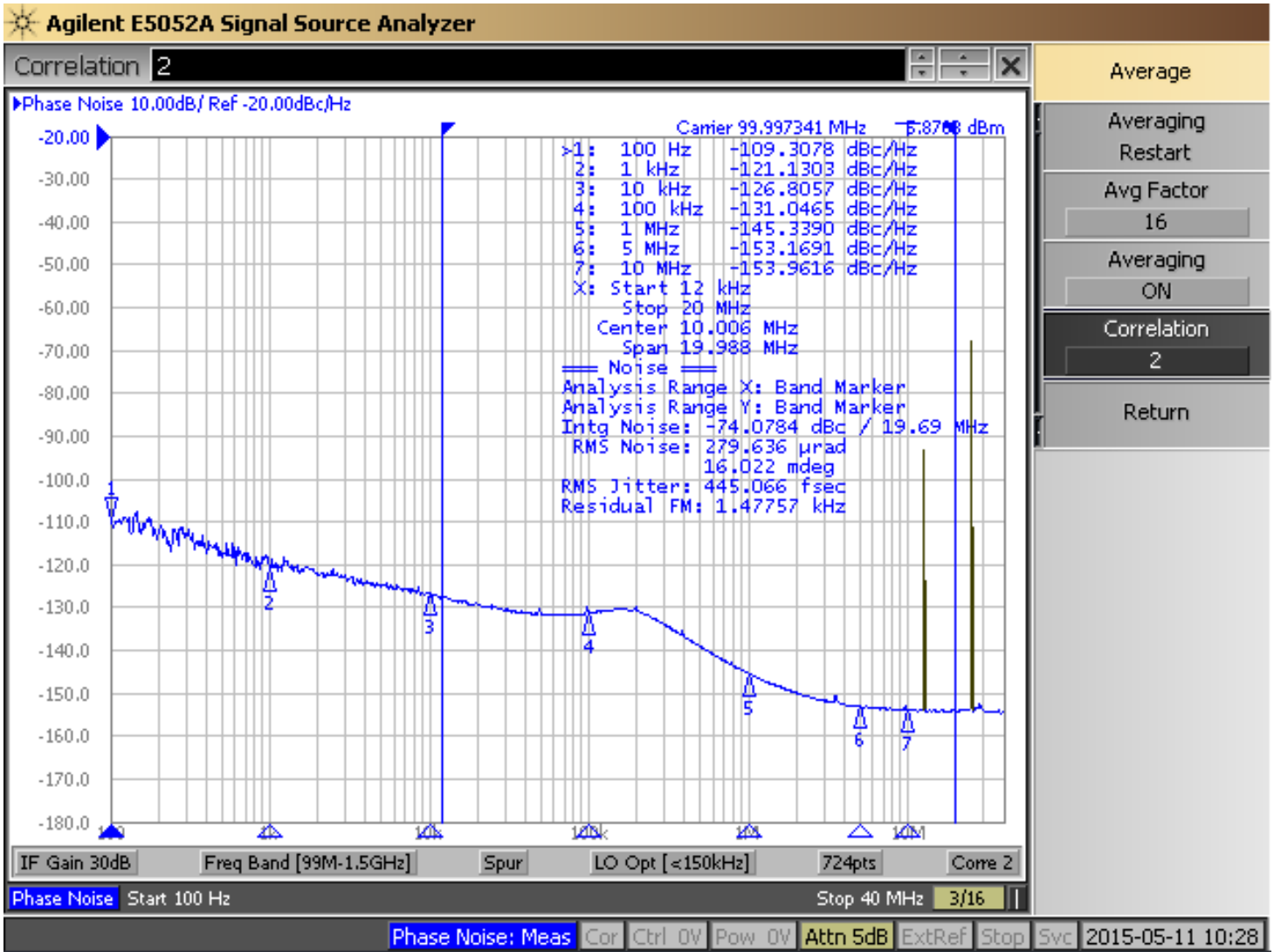

NOTE: Phase Noise Plot taken from the configuration in Table 21, spec t6. Spurs on.

5P49V6913 Applications Schematic

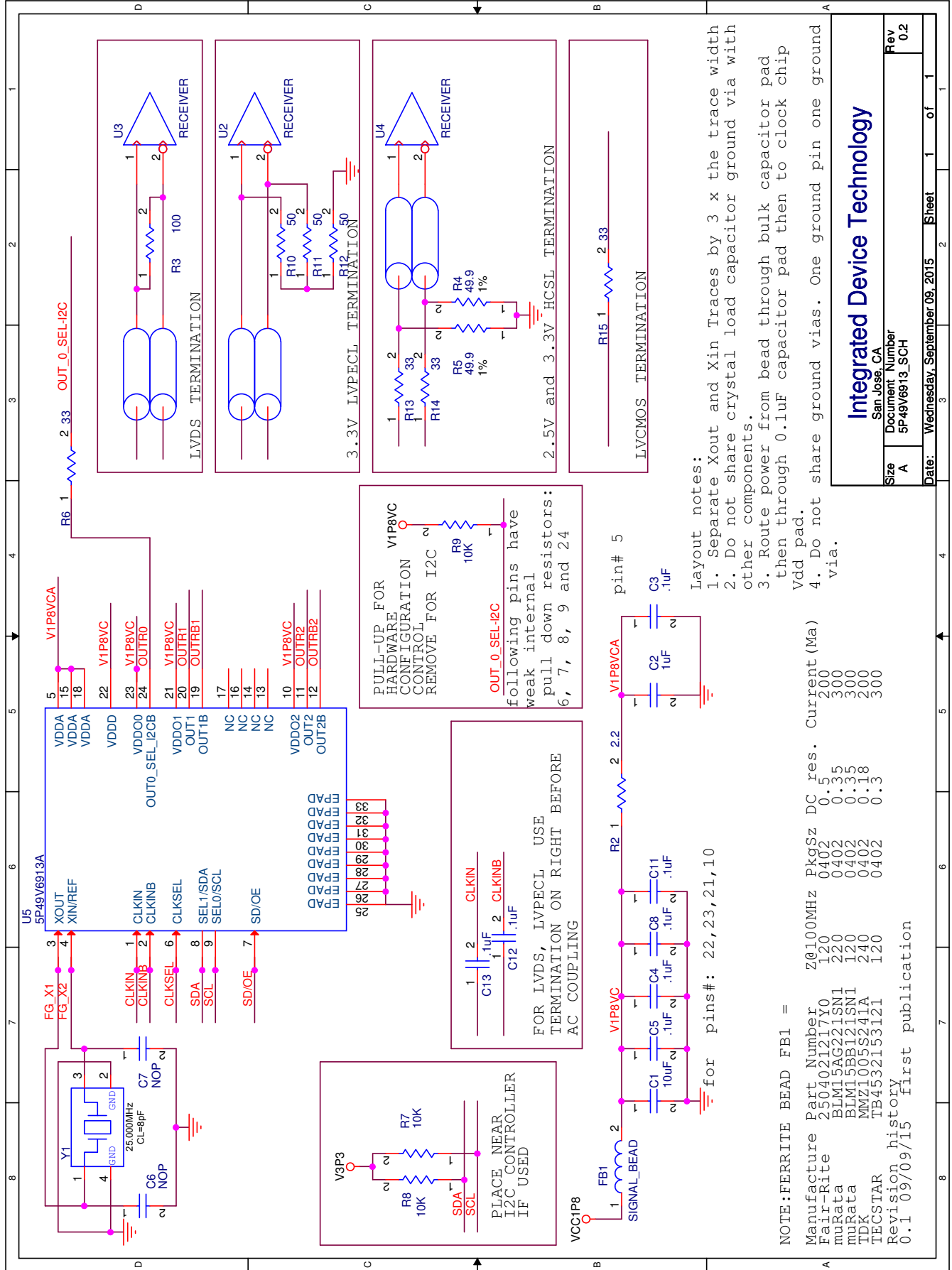

Integrated Device Technology
San Jose, CA

Size	Document Number	Rev
A	5P49V6913_SCH	0.2

Date: Wednesday, September 09, 2015 Sheet 1 of 1

Overdriving the XIN/REF Interface

LVC MOS Driver

The XIN/REF input can be overdriven by an LVC MOS driver or by one side of a differential driver through an AC coupling capacitor. The XOUT pin can be left floating. The amplitude of the input signal should be between 500mV and 1.2V and the slew rate should not be less than 0.2V/ns. Figure General Diagram for LVC MOS Driver to XTAL Input Interface shows an example of the interface diagram for a LVC MOS driver.

This configuration has three properties; the total output impedance of R_o and R_s matches the 50 ohm transmission line impedance, the V_{rx} voltage is generated at the CLKIN inputs which maintains the LVC MOS driver voltage level across the transmission line for best S/N and the R_1 - R_2 voltage divider values ensure that the clock level at XIN is less than the maximum value of 1.2V.

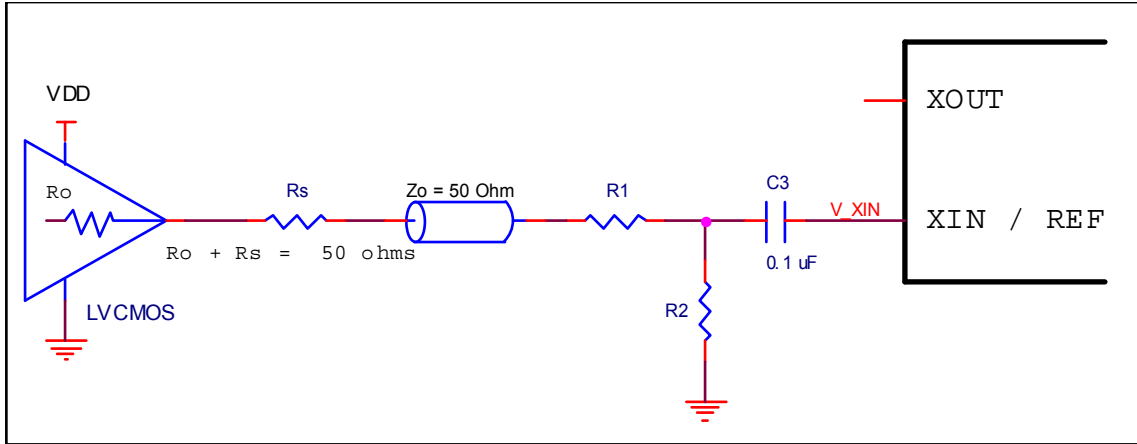

General Diagram for LVC MOS Driver to XTAL Input Interface

Table 25 Nominal Voltage Divider Values vs LVC MOS VDD for XIN shows resistor values that ensure the maximum drive level for the XIN/REF port is not exceeded for all combinations of 5% tolerance on the driver VDD, the VersaClock VDDA and 5% resistor tolerances. The values of the resistors can be

adjusted to reduce the loading for slower and weaker LVC MOS driver by increasing the voltage divider attenuation as long as the minimum drive level is maintained over all tolerances. To assist this assessment, the total load on the driver is included in the table.

Table 25: Nominal Voltage Divider Values vs LVC MOS VDD for XIN

LVC MOS Driver VDD	R_o+R_s	R_1	R_2	V_{XIN} (peak)	$R_o+R_s+R_1+R_2$
3.3	50.0	130	75	0.97	255
2.5	50.0	100	100	1.00	250
1.8	50.0	62	130	0.97	242

LVPECL Driver

Figure General Diagram for LVPECL Driver to XTAL Input Interface shows an example of the interface diagram for a +3.3V LVPECL driver. This is a standard LVPECL termination with one side of the driver feeding the XIN/REF input. It is recommended that all components in the schematics be placed in the layout; though some components might not be

used, they can be utilized for debugging purposes. The datasheet specifications are characterized and guaranteed by using a quartz crystal as the input. If the driver is 2.5V LVPECL, the only change necessary is to use the appropriate value of R3.

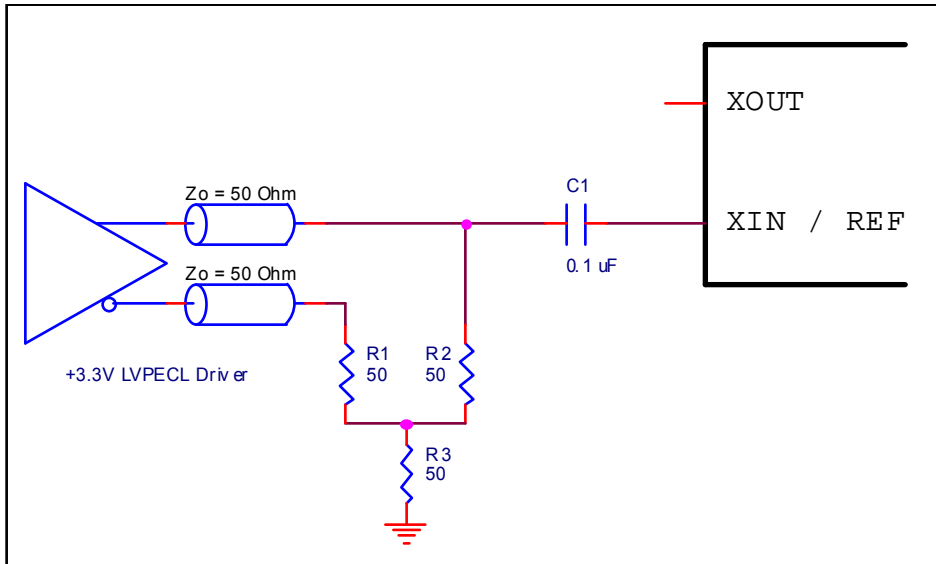

General Diagram for +3.3V LVPECL Driver to XTAL Input Interface

CLKIN Equivalent Schematic

Figure *CLKIN Equivalent Schematic* below shows the basis of the requirements on VIH max, VIL min and the 1200 mV p-p single ended Vswing maximum.

- The CLKIN and CLKINB Vih max spec comes from the cathode voltage on the input ESD diodes D2 and D4, which are referenced to the internal 1.2V supply. CLKIN or CLKINB voltages greater than $1.2V + 0.5V = 1.7V$ will be clamped by these diodes. CLKIN and CLKINB input voltages less than $-0.3V$ will be clamped by diodes D1 and D3.
- The 1.2V p-p maximum Vswing input requirement is determined by the internally regulated 1.2V supply for the actual clock receiver. This is the basis of the Vswing spec in Table 13.

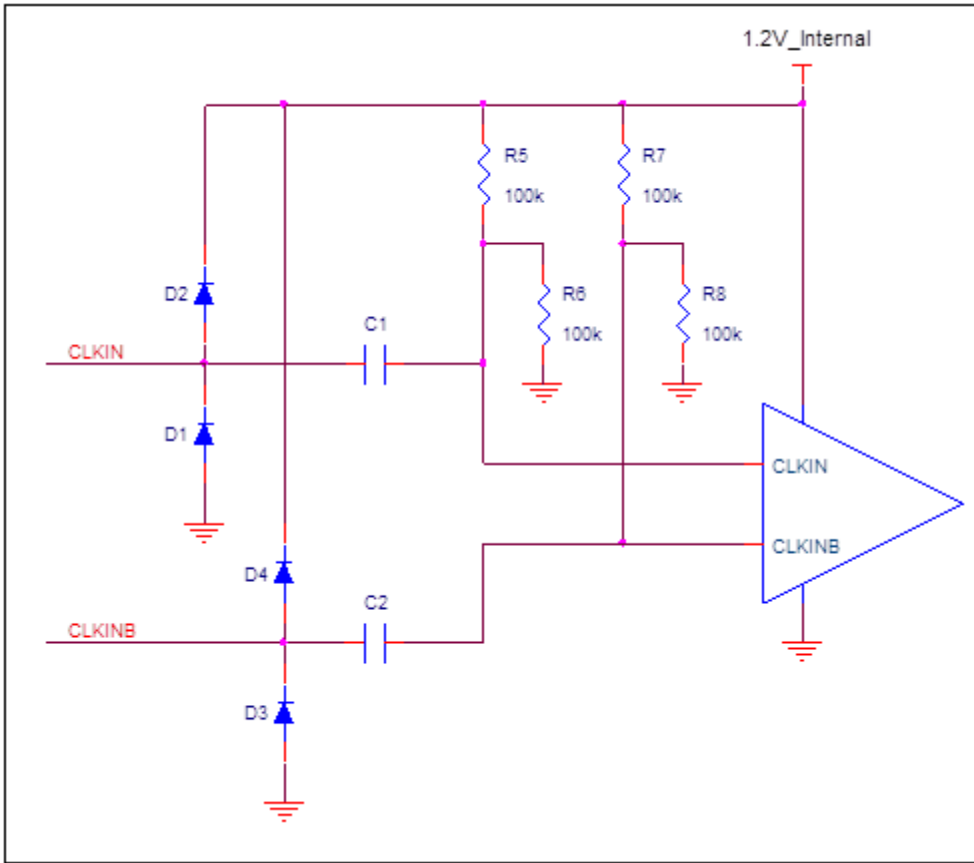

CLKIN Equivalent Schematic

Wiring the Differential Input to Accept Single-Ended Levels

Figure *Recommended Schematic for Wiring a Differential Input to Accept Single-ended Levels* shows how a differential input can be wired to accept single ended levels. This configuration has three properties; the total output impedance of R_o and R_s matches the 50 ohm transmission line

impedance, the V_{rx} voltage is generated at the CLKIN inputs which maintains the LVCMOS driver voltage level across the transmission line for best S/N and the R1-R2 voltage divider values ensure that V_{rx} p-p at CLKIN is less than the maximum value of 1.2V.

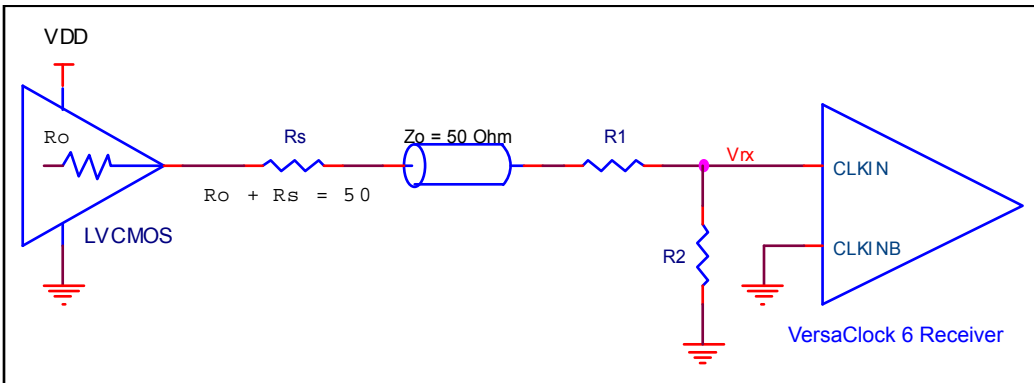

Recommended Schematic for Wiring a Differential Input to Accept Single-ended Levels

Table 26 Nominal Voltage Divider Values vs Driver VDD shows resistor values that ensure the maximum drive level for the CLKIN port is not exceeded for all combinations of 5% tolerance on the driver VDD, the VersaClock Vddo_0 and 5% resistor tolerances. The values of the resistors can be

adjusted to reduce the loading for slower and weaker LVCMOS driver by increasing the impedance of the R1-R2 divider. To assist this assessment, the total load on the driver is included in the table.

Table 26: Nominal Voltage Divider Values vs Driver VDD

LVCMOS Driver VDD	Ro+Rs	R1	R2	Vrx (peak)	Ro+Rs+R1+R2
3.3	50.0	130	75	0.97	255
2.5	50.0	100	100	1.00	250
1.8	50.0	62	130	0.97	242

HCSL Differential Clock Input Interface

CLKIN/CLKINB will accept DC coupled HCSL signals.

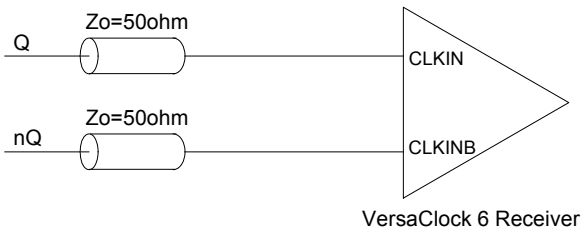

CLKIN, CLKINB Input Driven by an HCSL Driver

3.3V LVPECL Clock Input Interface

The logic levels of 3.3V LVPECL and LVDS can exceed VIH max for the CLKIN/B pins. Therefore the LVPECL levels must be AC coupled to the VersaClock differential input and the DC bias restored with external voltage dividers. A single table of

bias resistor values is provided below for both for 3.3V LVPECL and LVDS. Vbias can be VDDD, VDDOX or any other available voltage at the VersaClock receiver that is most conveniently accessible in layout.

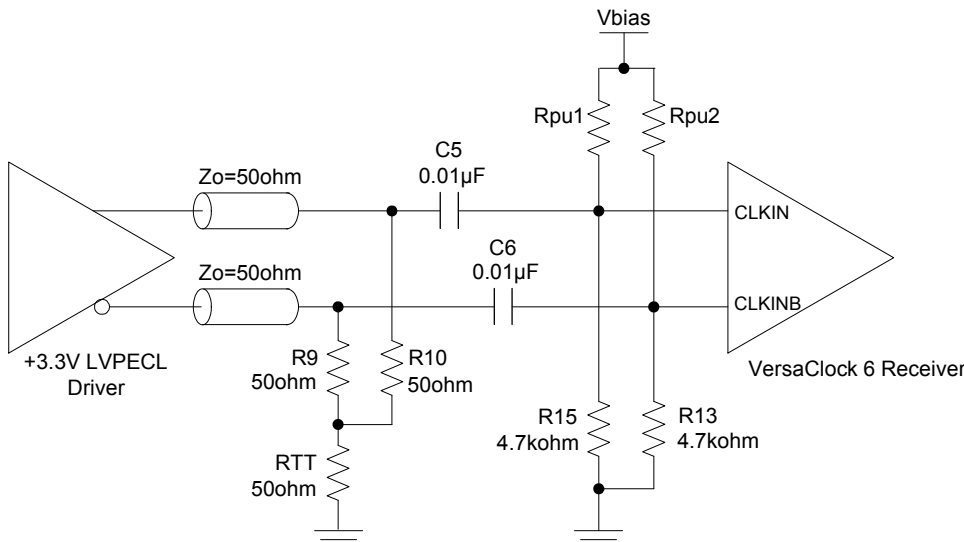

CLKIN, CLKINB Input Driven by a 3.3V LVPECL Driver

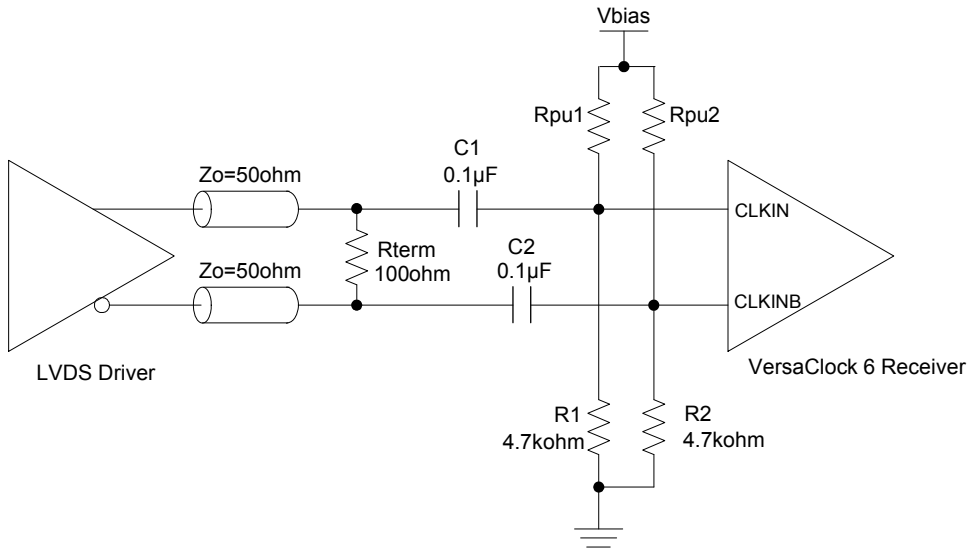

CLKIN, CLKINB Input Driven by an LVDS Driver

Table 27: Bias Resistors for 3.3V LVPECL and LVDS Drive to CLKIN/B

Vbias (V)	Rpu1/2 (kohm)	CLKIN/B Bias Voltage (V)
3.3	22	0.58
2.5	15	0.60
1.8	10	0.58

2.5V Differential LVPECL Clock Input Interface

The maximum DC 2.5V LVPECL voltage meets the VIH max CLKIN requirement. Therefore 2.5V LVPECL can be connected directly to the CLKIN terminals without AC coupling

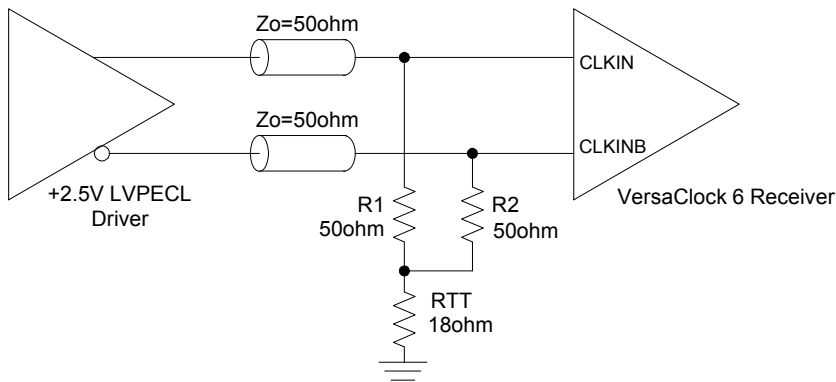

CLKIN, CLKINB Input Driven by a 2.5V LVPECL Driver

LVDS Driver Termination

For a general LVDS interface, the recommended value for the termination impedance (Z_T) is between 90Ω and 132Ω . The actual value should be selected to match the differential impedance (Z_0) of your transmission line. A typical point-to-point LVDS design uses a 100Ω parallel resistor at the receiver and a 100Ω differential transmission-line environment. In order to avoid any transmission-line reflection issues, the components should be surface mounted and must be placed as close to the receiver as possible. The standard termination schematic as shown in figure *Standard Termination* or the termination of figure *Optional Termination* can be used, which uses a center tap capacitance to help filter

common mode noise. The capacitor value should be approximately 50pF . In addition, since these outputs are LVDS compatible, the input receiver's amplitude and common-mode input range should be verified for compatibility with the IDT LVDS output. If using a non-standard termination, it is recommended to contact IDT and confirm that the termination will function as intended. For example, the LVDS outputs cannot be AC coupled by placing capacitors between the LVDS outputs and the 100 ohm shunt load. If AC coupling is required, the coupling caps must be placed between the 100 ohm shunt termination and the receiver. In this manner the termination of the LVDS output remains DC coupled.

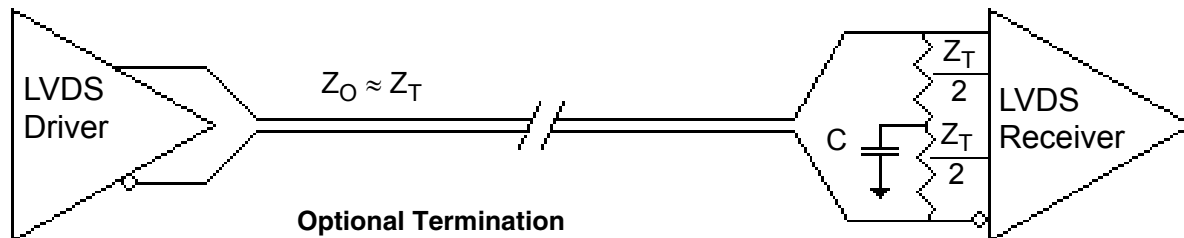
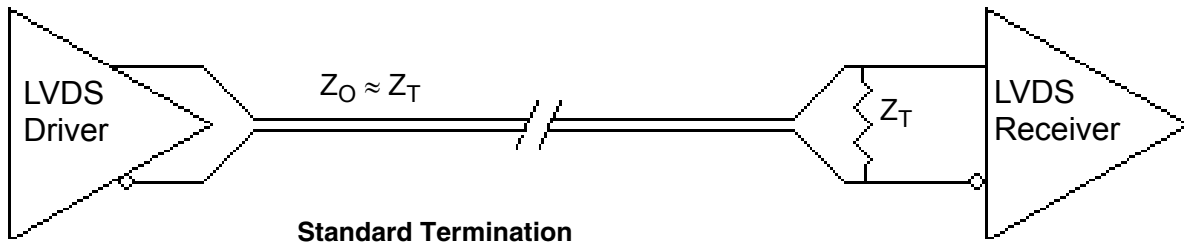

Termination for 3.3V LVPECL Outputs

The clock layout topology shown below is a typical termination for LVPECL outputs. The two different layouts mentioned are recommended only as guidelines.

The differential outputs generate ECL/LVPECL compatible outputs. Therefore, terminating resistors (DC current path to ground) or current sources must be used for functionality. These outputs are designed to drive 50Ω transmission lines. Matched impedance techniques should be used to maximize operating frequency and minimize signal distortion. The figure below show two different layouts which are recommended only as guidelines. Other suitable clock layouts may exist and it would be recommended that the board designers simulate to guarantee compatibility across all printed circuit and clock component process variations.

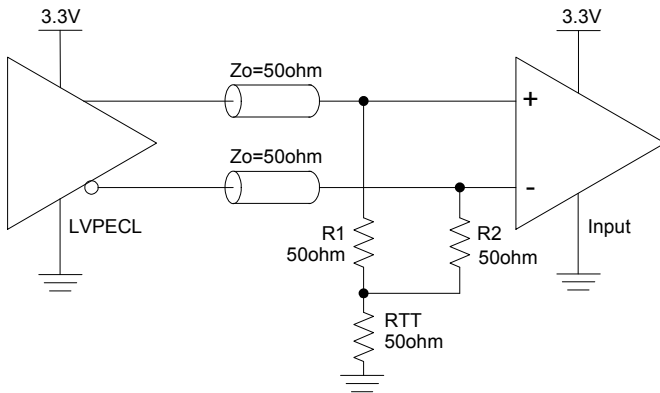

3.3V LVPECL Output Termination (1)

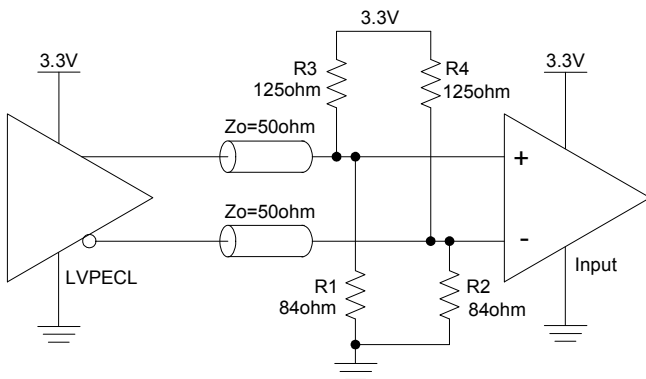

3.3V LVPECL Output Termination (2)

Termination for 2.5V LVPECL Outputs

Figures 2.5V LVPECL Driver Termination Example (1) and (2) show examples of termination for 2.5V LVPECL driver. These terminations are equivalent to terminating 50Ω to $V_{DDO} - 2V$. For $V_{DDO} = 2.5V$, the $V_{DDO} - 2V$ is very close to ground level. The R3 in Figure 2.5V LVPECL Driver Termination Example (3) can be eliminated and the termination is shown in example (2).

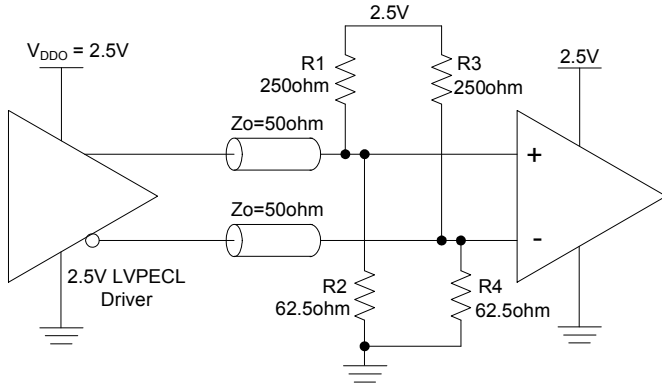

2.5V LVPECL Driver Termination Example (1)

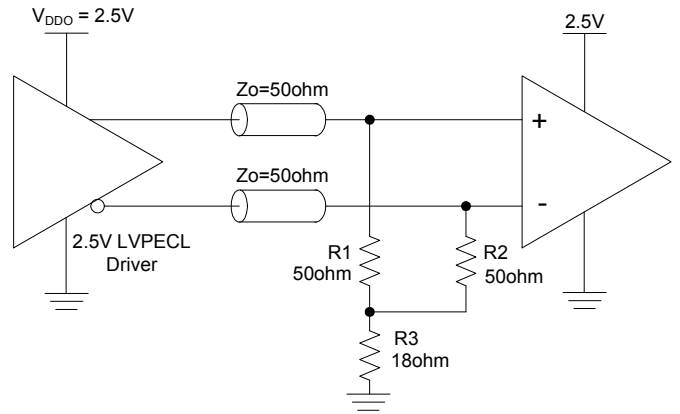

2.5V LVPECL Driver Termination Example (3)

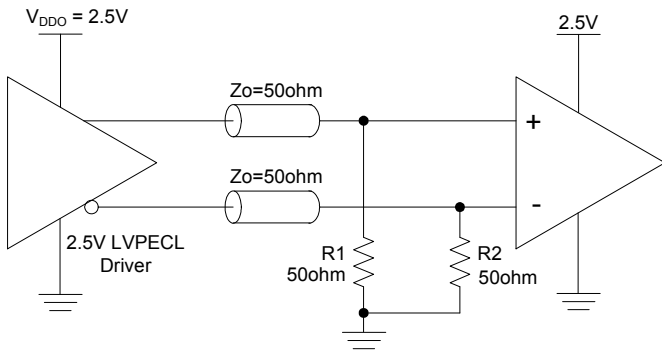

2.5V LVPECL Driver Termination Example (2)

PCI Express Application Note

PCI Express jitter analysis methodology models the system response to reference clock jitter. The block diagram below shows the most frequently used Common Clock Architecture in which a copy of the reference clock is provided to both ends of the PCI Express Link.

In the jitter analysis, the transmit (Tx) and receive (Rx) serdes PLLs are modeled as well as the phase interpolator in the receiver. These transfer functions are called H1, H2, and H3 respectively. The overall system transfer function at the receiver is:

$$H_t(s) = H_3(s) \times [H_1(s) - H_2(s)]$$

The jitter spectrum seen by the receiver is the result of applying this system transfer function to the clock spectrum X(s) and is:

$$Y(s) = X(s) \times H_3(s) \times [H_1(s) - H_2(s)]$$

In order to generate time domain jitter numbers, an inverse Fourier Transform is performed on $X(s) \times H_3(s) \times [H_1(s) - H_2(s)]$.

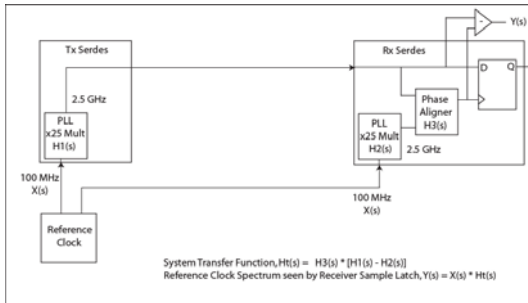

PCI Express Common Clock Architecture

For PCI Express Gen 1, one transfer function is defined and the evaluation is performed over the entire spectrum: DC to Nyquist (e.g for a 100MHz reference clock: 0Hz – 50MHz) and the jitter result is reported in peak-peak.

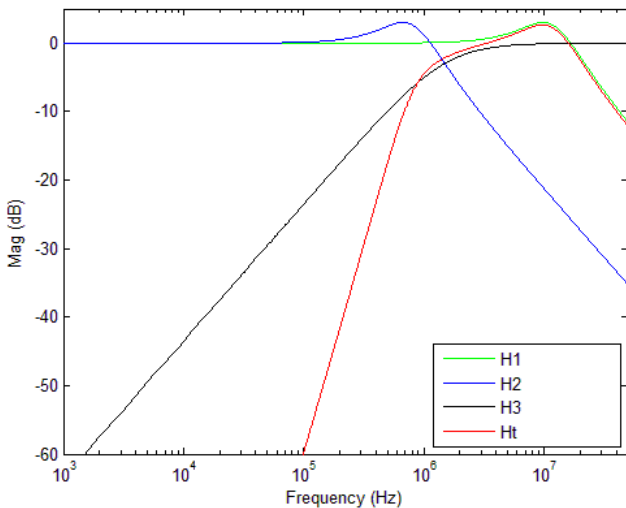

PCI Express Gen1 Magnitude of Transfer Function

For PCI Express Gen2, two transfer functions are defined with 2 evaluation ranges and the final jitter number is reported in RMS. The

two evaluation ranges for PCI Express Gen 2 are 10kHz – 1.5MHz (Low Band) and 1.5MHz – Nyquist (High Band). The plots show the individual transfer functions as well as the overall transfer function Ht.

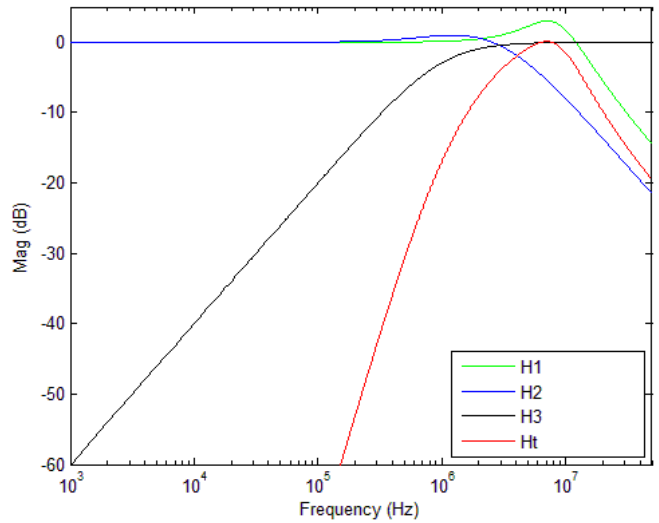

PCI Express Gen2A Magnitude of Transfer Function

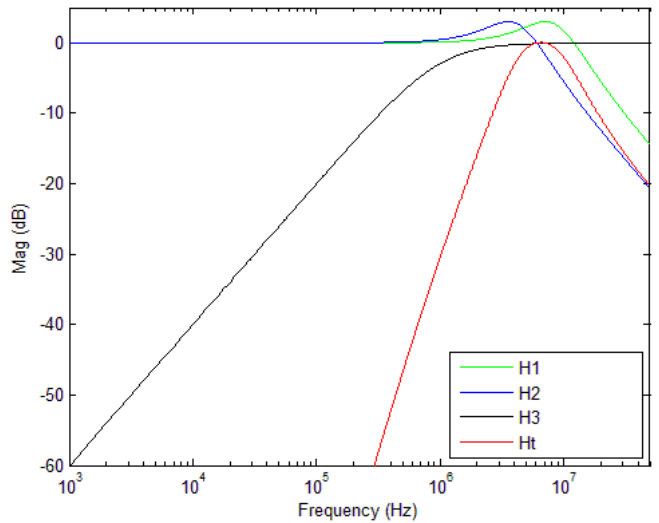

PCI Express Gen2B Magnitude of Transfer Function

For PCI Express Gen 3, one transfer function is defined and the evaluation is performed over the entire spectrum. The transfer function parameters are different from Gen 1 and the jitter result is reported in RMS.

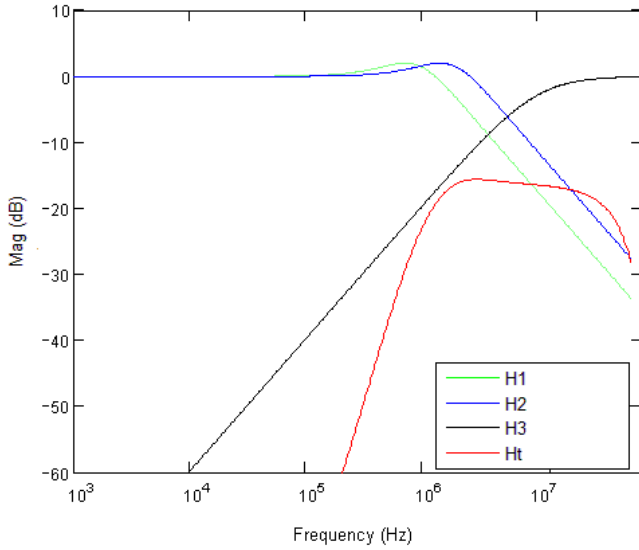

PCIe Gen3 Magnitude of Transfer Function

For a more thorough overview of PCI Express jitter analysis methodology, please refer to IDT Application Note PCI Express Reference Clock Requirements.

Marking Diagram

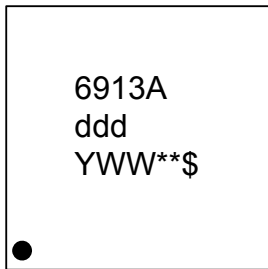

1. Line 1 is the truncated part number.
2. “ddd” denotes dash code.
3. “YWW” is the last digit of the year and week that the part was assembled.
4. “**” denotes lot number.
5. “\$” denotes mark code.

Package Outline Drawings

The package outline drawings are appended at the end of this document and are accessible from the link below. The package information is the most current data available.

www.idt.com/document/psc/nlnlg24-package-outline-40-x-40-mm-body-05-mm-pitch-qfn-epad-size-280-x-280-mm

Ordering Information

Part / Order Number	Shipping Packaging	Package	Temperature
5P49V6913AdddNLGI	Trays	24-VFQFPN	-40° to +85°C
5P49V6913AdddNLGI8	Tape and Reel	24-VFQFPN	-40° to +85°C

“G” after the two-letter package code denotes Pb-Free configuration, RoHS compliant.

Revision History

Date	Description of Change
September 15, 2015	Initial release.
October 22, 2015	Updated ordering information and marking diagram to replace "000" dash code designator with "ddd".
November 12, 2015	Updated AC Characteristics table (fIN ~ t4).
September 19, 2016	Corrected typo [Ci1 to Cs1] on page 5.
October 12, 2016	Updated POD with latest version of PSC-4192.
October 19, 2016	Removed IDT crystal part number
November 11, 2016	Corrected typo for the order of t4 Slew Rates
September 12, 2018	Corrected typo for Power Down Current units from μ A to mA.

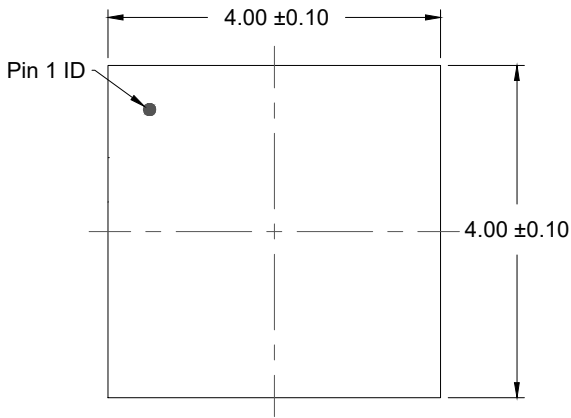

TOP VIEW

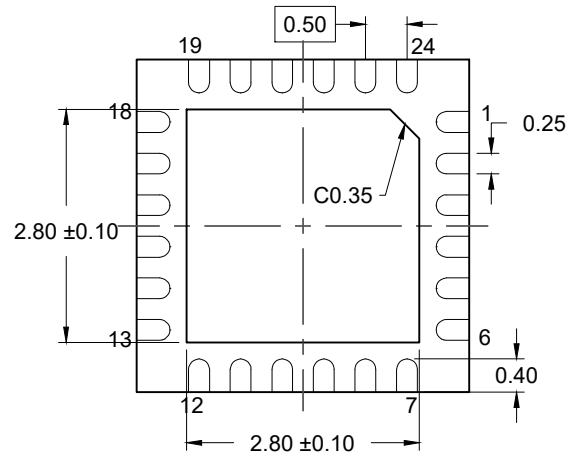

BOTTOM VIEW

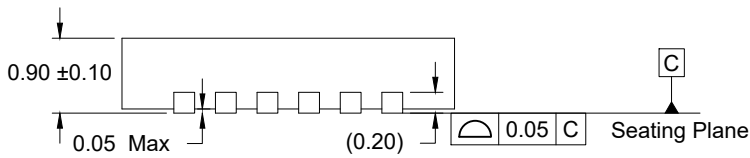

SIDE VIEW

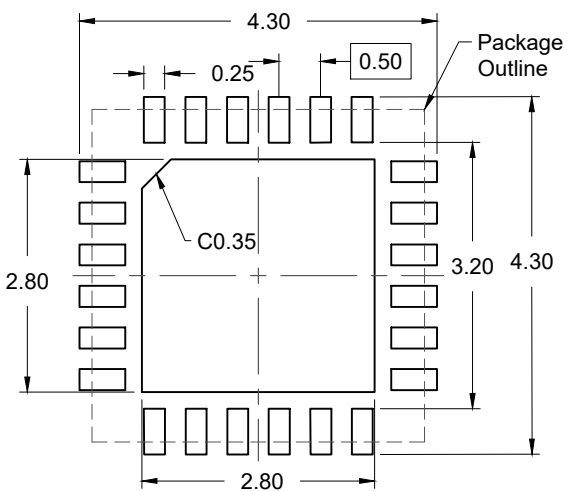

RECOMMENDED LAND PATTERN
(PCB Top View, NSMD Design)

NOTES:

1. JEDEC compatible.
2. All dimensions are in mm and angles are in degrees.
3. Use ± 0.05 mm for the non-toleranced dimensions.
4. Numbers in () are for references only.

IMPORTANT NOTICE AND DISCLAIMER

RENESAS ELECTRONICS CORPORATION AND ITS SUBSIDIARIES (“RENESAS”) PROVIDES TECHNICAL SPECIFICATIONS AND RELIABILITY DATA (INCLUDING DATASHEETS), DESIGN RESOURCES (INCLUDING REFERENCE DESIGNS), APPLICATION OR OTHER DESIGN ADVICE, WEB TOOLS, SAFETY INFORMATION, AND OTHER RESOURCES “AS IS” AND WITH ALL FAULTS, AND DISCLAIMS ALL WARRANTIES, EXPRESS OR IMPLIED, INCLUDING, WITHOUT LIMITATION, ANY IMPLIED WARRANTIES OF MERCHANTABILITY, FITNESS FOR A PARTICULAR PURPOSE, OR NON-INFRINGEMENT OF THIRD-PARTY INTELLECTUAL PROPERTY RIGHTS.

These resources are intended for developers who are designing with Renesas products. You are solely responsible for (1) selecting the appropriate products for your application, (2) designing, validating, and testing your application, and (3) ensuring your application meets applicable standards, and any other safety, security, or other requirements. These resources are subject to change without notice. Renesas grants you permission to use these resources only to develop an application that uses Renesas products. Other reproduction or use of these resources is strictly prohibited. No license is granted to any other Renesas intellectual property or to any third-party intellectual property. Renesas disclaims responsibility for, and you will fully indemnify Renesas and its representatives against, any claims, damages, costs, losses, or liabilities arising from your use of these resources. Renesas' products are provided only subject to Renesas' Terms and Conditions of Sale or other applicable terms agreed to in writing. No use of any Renesas resources expands or otherwise alters any applicable warranties or warranty disclaimers for these products.

(Disclaimer Rev.1.01)

Corporate Headquarters

TOYOSU FORESIA, 3-2-24 Toyosu,
Koto-ku, Tokyo 135-0061, Japan
www.renesas.com

Trademarks

Renesas and the Renesas logo are trademarks of Renesas Electronics Corporation. All trademarks and registered trademarks are the property of their respective owners.

Contact Information

For further information on a product, technology, the most up-to-date version of a document, or your nearest sales office, please visit www.renesas.com/contact-us/.