

## Description

The ICS650-27 is a low cost, low jitter, high performance clock synthesizer for networking applications. Using analog Phase-Locked Loop (PLL) techniques, the device accepts a 12.5 MHz or 25 MHz clock or fundamental mode crystal input to produce multiple output clocks for networking chips, PCI devices, SDRAM, and ASICs. The ICS650-27 outputs all have zero ppm synthesis error.

**The ICS650-27 is pin compatible and functionally equivalent to the ICS650-07. It is a performance upgrade and is recommended for all new 3.3V designs.**

See the MK74CB214, ICS551, and ICS552-01 for non-PLL buffer devices which produce multiple low-skew copies of these output clocks.

See the ICS570, ICS9112-16/17/18 for zero delay buffers that can synchronize outputs and other needed clocks.

## Features

- Packaged in 20-pin (150 mil) SSOP (QSOP)
- Pb (lead) free package, RoHS compliant
- 12.5 MHz or 25 MHz fundamental crystal or clock input
- Six output clocks with selectable frequencies
- SDRAM frequencies of 67, 83, 100, and 133 MHz
- Buffered crystal reference output
- Zero ppm synthesis error in all clocks
- Ideal for PMC-Sierra's ATM switch chips
- Full CMOS output swing with 25 mA output drive capability at TTL levels
- Advanced, low-power, sub-micron CMOS process
- Operating voltage of 3.3 V
- Industrial temperature only

## Block Diagram

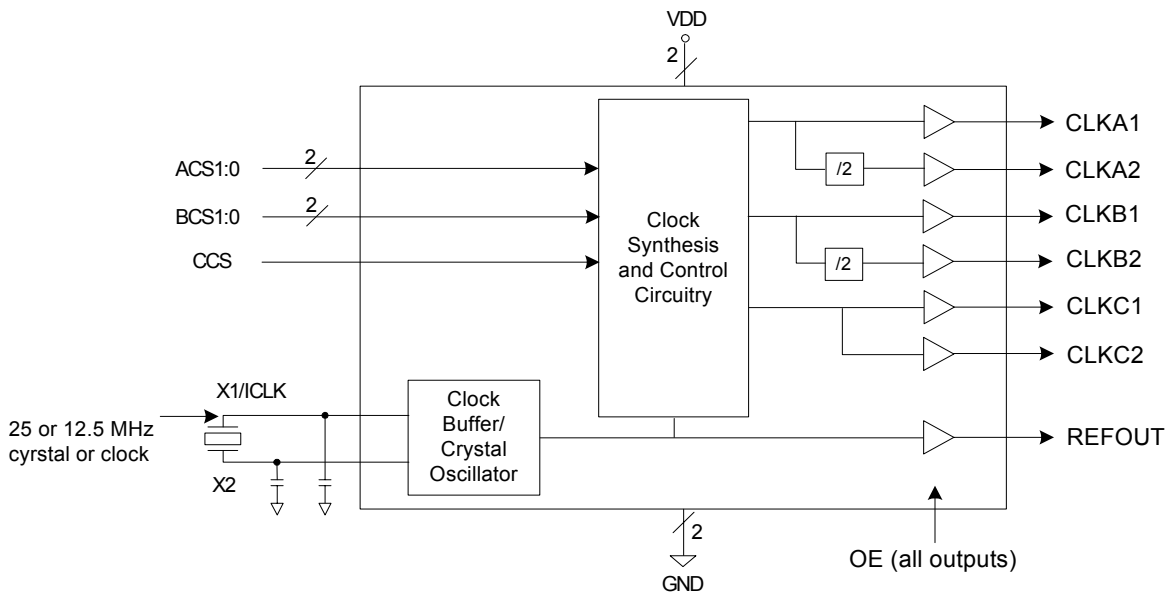

## Pin Assignment

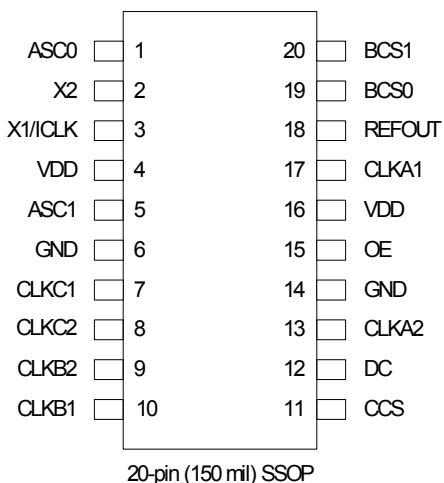

## Pin Descriptions

Pin Number	Pin Name	Pin Type	Pin Description
1	ACS0	Input	A clock select 0. Selects outputs on CLKA1 and CLKA2 per table on page 3.
2	X2	Input	Crystal connection. Connect to a fundamental crystal or leave unconnected for a clock input.
3	X1/ICLK	Input	Crystal connection. Connect to a fundamental crystal or clock input.
4	VDD	Power	Connect to +3.3 V or 5 V. Must be the same as pin 16.
5	ACS1	Input	A clock select 1. Selects outputs on CLKA1 and CLKA2 per table on page 3. Internal pull-up.
6	GND	Power	Connect to ground.
7	CLKC1	Output	Output Clock C1. Depends on setting of CCS per table on page 3.
8	CLKC2	Output	Output Clock C2. Depends on setting of CCS per table on page 3. Same as CLKC1.
9	CLKB2	Output	Output Clock B2. Depends on setting of BCS1, 0 per table on page 3.
10	CLKB1	Output	Output Clock B1. Depends on setting of BCS1, 0 per table on page 3.
11	CCS	Input	Clock C select pin. Selects outputs on CLKC1 and CLKC2 per table on page 3.
12	DC	-	Don't connect. Do not connect anything to this pin.
13	CLKA2	Output	Output Clock A2. Depends on setting of ACS1, 0 per table on page 3.
14	GND	Power	Connect to ground.
15	OE	Input	Output enable. Tri-states all outputs when low. Internal pull-up.
16	VDD	Power	Connect to +3.3 V or 5 V. Must be the same as pin 4.
17	CLKA1	Output	Output Clock A1. Depends on setting of ACS1, 0 per table on page 3.
18	REFOUT	Output	Buffered reference clock output. Same frequency as crystal or clock input.
19	BCS0	Input	B clock select 0. Selects outputs on CLKB1 and CLKB2 per table on page 3.
20	BCS1	Input	B clock select 1. Selects outputs on CLKB1 and CLKB2 per table on page 3. Internal pull-up.

For a 25 MHz fundamental crystal or clock input, the following four tables apply:

**A Clocks Select Table (outputs in MHz)**

ASC1	ASC0	CLKA1	CLKA2
0	0	100	off (low)
0	M	Test	Test
0	1	75	off (low)
1	0	33.3333	16.6667
1	M	Test	Test
1	1	66.6667	33.3333

**B Clocks Select Table (outputs in MHz)**

BSC1	BSC0	CLKB1	CLKB2
0	0	Test	Test
0	M	66.6667	33.3333
0	1	100	50
1	0	83.3333	41.6667
1	M	Test	Test
1	1	133.3333	66.6667

**C Clocks Select Table (outputs in MHz)**

CCS	CLKC1	CLKC2
0	125	125
M	Test	Test
1	75	75

**Reference Output Clock Frequency (in MHz)**

REFOUT
25

For a 12.5 MHz fundamental crystal or clock input, the following four tables apply:

**A Clocks Select Table (outputs in MHz)**

ASC1	ASC0	CLKA1	CLKA2
0	0	50	off (low)
0	M	Test	Test
0	1	37.5	off (low)
1	0	16.6667	8.3333
1	M	Test	Test
1	1	33.3333	16.6667

**B Clocks Select Table (outputs in MHz)**

BSC1	BSC0	CLKB1	CLKB2
0	0	Test	Test
0	M	33.3333	16.6667
0	1	50	25
1	0	41.6667	20.8333
1	M	Test	Test
1	1	66.6667	33.3333

**C Clocks Select Table (outputs in MHz)**

CCS	CLKC1	CLKC2
0	62.5	62.5
M	Test	Test
1	37.5	37.5

**Reference Output Clock Frequency (in MHz)**

REFOUT
12.5

0 = connect directly to GND

M = leave unconnected (automatically self biases to VDD/2)

1 = connect directly to VDD

## External Components

The ICS650-27 requires a minimum number of external components for proper operation.

### Decoupling Capacitor

Decoupling capacitors of 0.01 $\mu$ F must be connected between each VDD and GND (pins 4 and 6, pins 16 and 14), as close to the device as possible. For optimum device performance, the decoupling capacitor should be mounted on the component side of the PCB. Avoid the use of vias in the decoupling circuit.

### Series Termination Resistor

When the PCB trace between the clock outputs and the loads are over 1 inch, series termination should be used. To series terminate a 50 $\Omega$  trace (a commonly used trace impedance), place a 33 $\Omega$  resistor in series with the clock line as close to the clock output pin as possible. The nominal impedance of the clock output is 20 $\Omega$ .

### Crystal Information

The crystal used should be a fundamental mode (do not use third overtone), parallel resonant. Crystal capacitors should be connected from pins X1 to ground and X2 to ground to optimize the initial accuracy. The value of these capacitors is given by the following equation:

$$\text{Crystal caps (pF)} = (C_L - 6) \times 2$$

In the equation,  $C_L$  is the crystal load capacitance. So, for a crystal with a 16pF load capacitance, two 20 pF [(16-6) x 2] capacitors should be used.

## Absolute Maximum Ratings

Stresses above the ratings listed below can cause permanent damage to the ICS650-27. These ratings, which are standard values for IDT commercially rated parts, are stress ratings only. Functional operation of the device at these or any other conditions above those indicated in the operational sections of the specifications is not implied. Exposure to absolute maximum rating conditions for extended periods can affect product reliability. Electrical parameters are guaranteed only over the recommended operating temperature range.

Item	Rating
Supply Voltage, VDD	7 V
All Inputs and Outputs	-0.5 V to VDD+0.5 V
Ambient Operating Temperature	-40 to +85° C
Storage Temperature	-65 to +150° C
Junction Temperature	175° C
Soldering Temperature	260° C

## Recommended Operation Conditions

Parameter	Min.	Typ.	Max.	Units
Ambient Operating Temperature	-40		+85	°C
Power Supply Voltage (measured in respect to GND)	+3.0	+3.3	+3.6	V

## DC Electrical Characteristics

Unless stated otherwise,  $V_{DD} = 3.3\text{ V} \pm 10\%$ , Ambient Temperature  $-40$  to  $+85^\circ\text{C}$

Parameter	Symbol	Conditions	Min.	Typ.	Max.	Units
Operating Voltage	$V_{DD}$		3.0	3.3	3.6	V
Input High Voltage	$V_{IH}$	X1 pin only, CLK input	$V_{DD}/2+1$	$V_{DD}/2$		V
Input Low Voltage	$V_{IL}$	X1 pin only, CLK input		$V_{DD}/2$	$V_{DD}/2-1$	V
Input High Voltage	$V_{IH}$	all tri-level type inputs	$V_{DD}-0.5$			V
Input Low Voltage	$V_{IL}$	all tri-level type inputs			0.5	V
Input High Voltage	$V_{IH}$	all other inputs	2			V
Input Low Voltage	$V_{IL}$	all other inputs			0.8	V
Output High Voltage	$V_{OH}$	$I_{OH} = -25\text{ mA}$	2.4			V
Output Low Voltage	$V_{OL}$	$I_{OL} = 25\text{ mA}$			0.8	V
Output High Voltage, CMOS level	$V_{OH}$	$I_{OH} = -8\text{ mA}$	$V_{DD}-0.4$			V
Operating Supply Current	$I_{DD}$	No Load		50		mA
Short Circuit Current	$I_{OS}$	Each output		$\pm 50$		mA
Internal pull-up resistor	$R_{PU}$	BCS1, OE pins		510		$k\Omega$
		ACSI pin		120		$k\Omega$
Nominal output impedance	$Z_{OUT}$			20		$\Omega$

## AC Electrical Characteristics

Unless stated otherwise,  $V_{DD} = 3.3\text{ V} \pm 10\%$ , Ambient Temperature  $-40$  to  $+85^\circ\text{C}$

Parameter	Symbol	Conditions	Min.	Typ.	Max.	Units
Input Frequency			10	12.5 or 25	27	MHz
Output Rise Time	$t_{OR}$	0.8 to 2.0 V, Note 1			1.5	ns
Output Fall Time	$t_{OF}$	2.0 to 0.8 V, Note 1			1.5	ns
Output Clock Duty Cycle		At $V_{DD}/2$ , Note 1	40	50	60	%
Frequency Error		All clocks			0	ppm
Absolute Jitter, short term		Variation from mean, Note 1		$\pm 150$		ps

Note 1: Measured with 15 pF load

## Thermal Characteristics

Parameter	Symbol	Conditions	Min.	Typ.	Max.	Units
Thermal Resistance Junction to Ambient	$\theta_{JA}$	Still air		135		$^\circ\text{C/W}$
	$\theta_{JA}$	1 m/s air flow		93		$^\circ\text{C/W}$
	$\theta_{JA}$	3 m/s air flow		78		$^\circ\text{C/W}$
Thermal Resistance Junction to Case	$\theta_{JC}$			60		$^\circ\text{C/W}$

## Package Outline and Package Dimensions (20-pin SSOP, 150 Mil. Body)

Package dimensions are kept current with JEDEC Publication No. 95

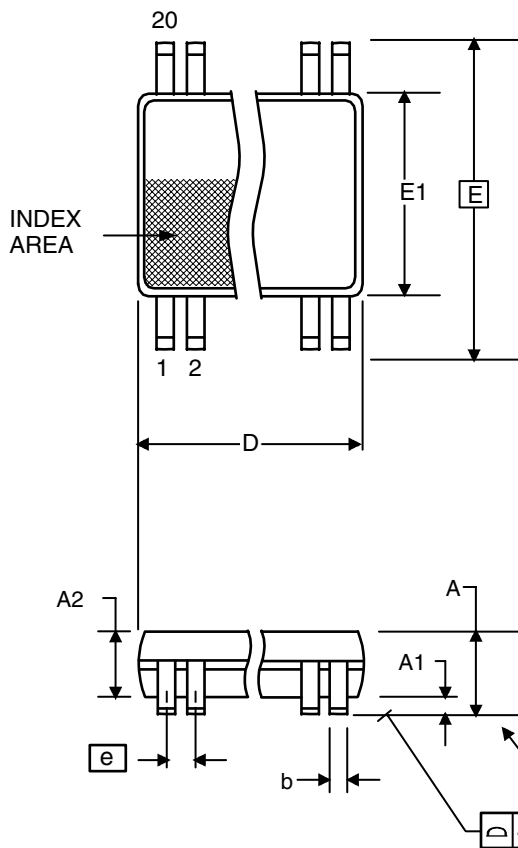

Symbol	Millimeters		Inches	
	Min	Max	Min	Max
A	1.35	1.75	.053	.069
A1	0.10	0.25	.0040	.010
A2	--	1.50	--	.059
b	0.20	0.30	0.008	0.012
C	0.18	0.25	.007	.010
D	8.55	8.75	.337	.344
E	5.80	6.20	.228	.244
E1	3.80	4.00	.150	.157
e	0.635 Basic		0.025 Basic	
L	0.40	1.27	.016	.050
$\alpha$	0°	8°	0°	8°

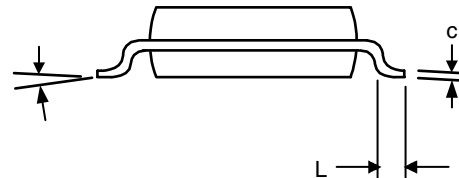

## Ordering Information

Part / Order Number	Marking	Shipping Packaging	Package	Temperature
650R-27ILF	650R-27ILF	Tubes	20-pin SSOP	-40 to +85° C
650R-27ILFT	650R-27ILF	Tape and Reel	20-pin SSOP	-40 to +85° C

"LF" suffix to the part number are the Pb-Free configuration and are RoHS compliant.

While the information presented herein has been checked for both accuracy and reliability, Integrated Device Technology (IDT) assumes no responsibility for either its use or for the infringement of any patents or other rights of third parties, which would result from its use. No other circuits, patents, or licenses are implied. This product is intended for use in normal commercial applications. Any other applications such as those requiring extended temperature range, high reliability, or other extraordinary environmental requirements are not recommended without additional processing by IDT. IDT reserves the right to change any circuitry or specifications without notice. IDT does not authorize or warrant any IDT product for use in life support devices or critical medical instruments.



## IMPORTANT NOTICE AND DISCLAIMER

RENESAS ELECTRONICS CORPORATION AND ITS SUBSIDIARIES (“RENESAS”) PROVIDES TECHNICAL SPECIFICATIONS AND RELIABILITY DATA (INCLUDING DATASHEETS), DESIGN RESOURCES (INCLUDING REFERENCE DESIGNS), APPLICATION OR OTHER DESIGN ADVICE, WEB TOOLS, SAFETY INFORMATION, AND OTHER RESOURCES “AS IS” AND WITH ALL FAULTS, AND DISCLAIMS ALL WARRANTIES, EXPRESS OR IMPLIED, INCLUDING, WITHOUT LIMITATION, ANY IMPLIED WARRANTIES OF MERCHANTABILITY, FITNESS FOR A PARTICULAR PURPOSE, OR NON-INFRINGEMENT OF THIRD-PARTY INTELLECTUAL PROPERTY RIGHTS.

These resources are intended for developers who are designing with Renesas products. You are solely responsible for (1) selecting the appropriate products for your application, (2) designing, validating, and testing your application, and (3) ensuring your application meets applicable standards, and any other safety, security, or other requirements. These resources are subject to change without notice. Renesas grants you permission to use these resources only to develop an application that uses Renesas products. Other reproduction or use of these resources is strictly prohibited. No license is granted to any other Renesas intellectual property or to any third-party intellectual property. Renesas disclaims responsibility for, and you will fully indemnify Renesas and its representatives against, any claims, damages, costs, losses, or liabilities arising from your use of these resources. Renesas' products are provided only subject to Renesas' Terms and Conditions of Sale or other applicable terms agreed to in writing. No use of any Renesas resources expands or otherwise alters any applicable warranties or warranty disclaimers for these products.

(Disclaimer Rev.1.01 Jan 2024)

### Corporate Headquarters

TOYOSU FORESIA, 3-2-24 Toyosu,  
Koto-ku, Tokyo 135-0061, Japan  
[www.renesas.com](http://www.renesas.com)

### Trademarks

Renesas and the Renesas logo are trademarks of Renesas Electronics Corporation. All trademarks and registered trademarks are the property of their respective owners.

### Contact Information

For further information on a product, technology, the most up-to-date version of a document, or your nearest sales office, please visit [www.renesas.com/contact-us/](http://www.renesas.com/contact-us/).