

General Description

The 810001-21 is a PLL based synchronous clock generator that is optimized for digital video clock jitter attenuation and frequency translation. The device contains two internal frequency multiplication stages that are cascaded in series. The first stage is a VCXO PLL that is optimized to provide reference clock jitter attenuation, and to support the complex PLL multiplication ratios needed for video rate conversion. The second stage is a FemtoClock™ frequency multiplier that provides the low jitter, high frequency video output clock.

Preset multiplication ratios are selected from internal lookup tables using device input selection pins. The multiplication ratios are optimized to support most common video rates used in professional video system applications. The VCXO requires the use of an external, inexpensive pullable crystal. Two crystal connections are provided (pin selectable) so that both 60 and 59.94 base frame rates can be supported. The VCXO requires external passive loop filter components which are used to set the PLL loop bandwidth and damping characteristics.

Features

- Jitter attenuation and frequency translation of video clock signals
- Supports SMPTE 292M, ITU-R Rec. 601/656 and MPEG-transport clocks
- Support of High-Definition (HD) and Standard-Definition (SD) pixel rates
- Dual VCXO-PLL supports both 60 and 59.94Hz base frame rates in one device
- Supports both 1000/1001 and 1001/1000 rate conversions
- Dual PLL mode for high-frequency clock generation (36MHz to 148.5MHz)
- VCXO-PLL mode for low-frequency clock generation (27MHz and 26.973MHz)
- One LVCMOS/LVTTL clock output
- Two selectable LVCMOS/LVTTL clock inputs
- LVCMOS/LVTTL compatible control signals
- RMS phase jitter @ 148.3516MHz, (12kHz - 20MHz): 1.089ps (typical)
- 3.3V supply voltage
- 0°C to 70°C ambient operating temperature
- Available in lead-free (RoHS 6) packages

Supported Input Frequencies

| $f_{VCXO} = 27\text{MHz}$ | $f_{VCXO} = 26.973\text{MHz}$ |
|---------------------------|-------------------------------|
| 27.0000MHz | 26.9730MHz |
| 27.0270MHz | 27.0000MHz |
| 74.1758MHz | 74.1016MHz |
| 74.3243MHz | 74.2499MHz |
| 74.2500MHz | 74.1758MHz |
| 27.0270MHz | 27.0000MHz |
| 26.9730MHz | 26.9461MHz |
| 74.1758MHz | 74.1016kHz |
| 45.0000kHz | 44.9550kHz |
| 33.7500kHz | 33.7163kHz |
| 15.6250kHz | 15.6094kHz |
| 15.7343kHz | 15.7185kHz |
| 28.1250kHz | 28.0969kHz |

Supported Output Frequencies

| $f_{VCXO} = 27\text{MHz}$ | $f_{VCXO} = 26.973\text{MHz}$ |
|---------------------------|-------------------------------|
| 148.5000MHz | 148.3515MHz |
| 74.2500MHz | 74.1758MHz |
| 49.5000MHz | 49.4505MHz |
| 33.0000MHz | 32.9670MHz |
| 162.0000MHz | 161.8380MHz |
| 81.0000MHz | 80.9190MHz |
| 54.0000MHz | 53.9460MHz |
| 36.0000MHz | 35.9640MHz |
| 27.0000MHz | 26.9730MHz |

Block Diagram

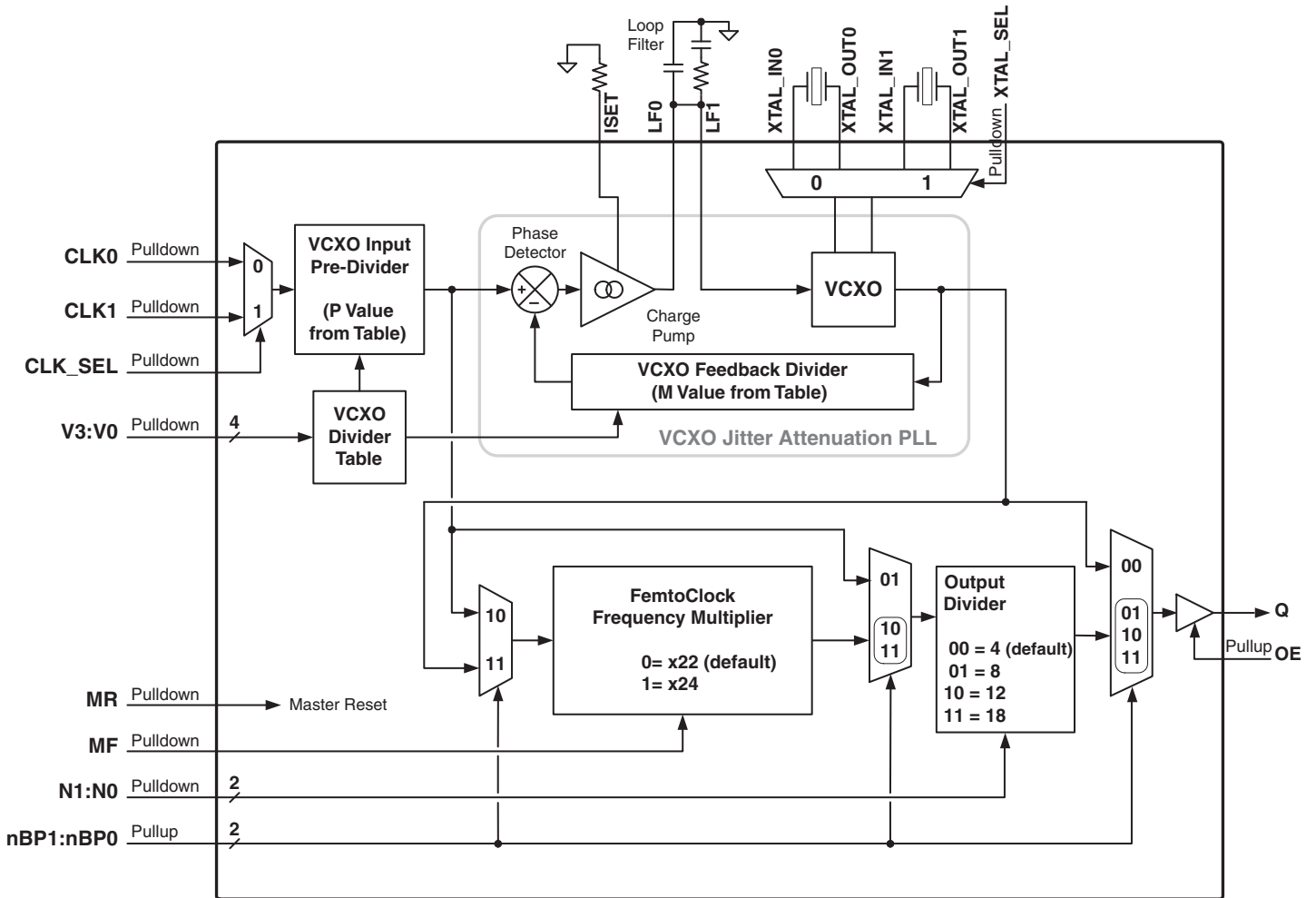

Pin Assignment

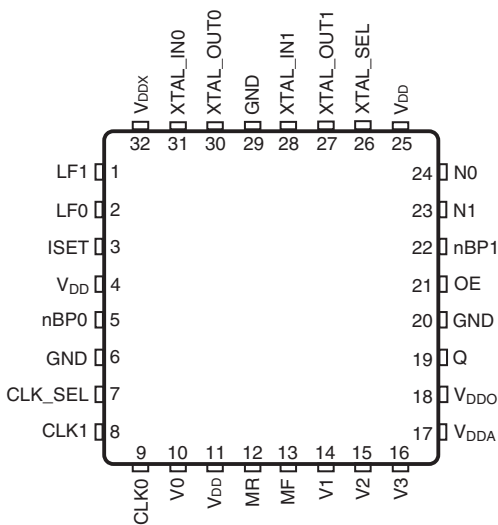

810001-21
32 Lead VFQFN
5mm x 5mm x 0.925mm
package body
K Package
Top View

Table 1. Pin Descriptions

| Number | Name | Type | | Description |
|----------------|---------------------|---------------------|----------|---|
| 1, 2 | LF1, LF0 | Analog Input/Output | | Loop filter connection node pins. |
| 3 | ISET | Analog Input/Output | | Charge pump current setting pin. |
| 4, 11, 25 | V _{DD} | Power | | Core supply pins. |
| 5, 22 | nBP0, nBP1 | Input | Pullup | PLL Bypass control pins. See block diagram. |
| 6, 20, 29 | GND | Power | | Power supply ground. |
| 7 | CLK_SEL | Input | Pulldown | Input clock select. When HIGH selects CLK1. When LOW, selects CLK0. LVCMOS / LVTTTL interface levels. |
| 8, 9 | CLK1, CLK0 | Input | Pulldown | Single-ended clock inputs. LVCMOS/LVTTTL interface levels. |
| 10, 14, 15, 16 | V0, V1, V2, V3 | Input | Pulldown | VCXO PLL divider selection pins. LVCMOS/LVTTTL interface levels. |
| 12 | MR | Input | Pulldown | Active HIGH Master Reset. When logic HIGH, the internal dividers are reset causing the output to go low. When logic LOW, the internal dividers and the output is enabled. LVCMOS/LVTTTL interface levels. |
| 13 | MF | Input | Pulldown | FemtoClock multiplication factor select pin. LVCMOS/LVTTTL interface levels. |
| 17 | V _{DDA} | Power | | Analog supply pin. |
| 18 | V _{DDO} | Power | | Output supply pin. |
| 19 | Q | Output | | Single-ended VCXO PLL clock output. LVCMOS/LVTTTL interface levels. |
| 21 | OE | Input | Pullup | Output enable. When logic LOW, the clock output is in high-impedance. When logic HIGH, the output is enabled. LVCMOS/LVTTTL interface levels. |
| 23, 24 | N1, N0 | Input | Pulldown | FemtoClock output divide select pins. LVCMOS/LVTTTL interface levels. |
| 26 | XTAL_SEL | Input | Pulldown | Crystal select. When HIGH, selects XTAL1. When LOW, selects XTAL0. LVCMOS/LVTTTL interface levels. |
| 27, 28 | XTAL_OUT1, XTAL_IN1 | Input | | Crystal oscillator interface. XTAL_IN1 is the input. XTAL_OUT1 is the output. |
| 30, 31 | XTAL_OUT0, XTAL_IN0 | Input | | Crystal oscillator interface. XTAL_IN0 is the input. XTAL_OUT0 is the output. |
| 32 | V _{DDX} | Power | | Power supply pin for VCXO charge pump. |

NOTE: *Pullup* and *Pulldown* refer to internal input resistors. See Table 2, *Pin Characteristics*, for typical values.

Table 2. Pin Characteristics

| Symbol | Parameter | Test Conditions | Minimum | Typical | Maximum | Units |
|-----------------------|--|---|---------|---------|---------|-------|
| C _{IN} | Input Capacitance | | | 4 | | pF |
| C _{PD} | Power Dissipation Capacitance (per output) | V _{DD} = V _{DDO} = 3.465V | | 8.5 | | pF |
| R _{PULLUP} | Input Pullup Resistor | | | 51 | | kΩ |
| R _{PULLDOWN} | Input Pulldown Resistor | | | 51 | | kΩ |
| R _{OUT} | Output Impedance | | | 22.5 | | Ω |

Function Tables

Table 3A. VCXO PLL Pre- and Feedback Divider Function Table

| Input | | | | VCXO PLL Configuration | |
|-------------|-------------|-------------|-------------|------------------------|---------------------|
| V3 | V2 | V1 | V0 | Pre-Divider P | Feedback- Divider M |
| 0 (default) | 0 (default) | 0 (default) | 0 (default) | 1000 | 1000 |
| 0 | 0 | 0 | 1 | 1001 | 1000 |
| 0 | 0 | 1 | 0 | 11000 | 4004 |
| 0 | 0 | 1 | 1 | 11011 | 4000 |
| 0 | 1 | 0 | 0 | 11000 | 4000 |
| 0 | 1 | 0 | 1 | 4004 | 4004 |
| 0 | 1 | 1 | 0 | 4004 | 4000 |
| 0 | 1 | 1 | 1 | 1000 | 1001 |
| 1 | 0 | 0 | 0 | 250 | 91 |
| 1 | 0 | 0 | 1 | 253 | 92 |
| 1 | 0 | 1 | 0 | 92 | 92 |
| 1 | 0 | 1 | 1 | 1 | 600 |
| 1 | 1 | 0 | 0 | 1 | 800 |
| 1 | 1 | 0 | 1 | 1 | 1728 |
| 1 | 1 | 1 | 0 | 1 | 1716 |
| 1 | 1 | 1 | 1 | 1 | 960 |

Table 3B. Input Frequency Table

| Input | | | | Crystal Frequency (f_{VCXO}) | |
|-------------|-------------|-------------|-------------|----------------------------------|------------|
| V3 | V2 | V1 | V0 | 27MHz | 26.973MHz |
| 0 (default) | 0 (default) | 0 (default) | 0 (default) | 27.0000MHz | 26.9730MHz |
| 0 | 0 | 0 | 1 | 27.0270MHz | 27.0000MHz |
| 0 | 0 | 1 | 0 | 74.1758MHz | 74.1016MHz |
| 0 | 0 | 1 | 1 | 74.3243MHz | 74.2499MHz |
| 0 | 1 | 0 | 0 | 74.2500MHz | 74.1758MHz |
| 0 | 1 | 0 | 1 | 27.0000MHz | 26.9730MHz |
| 0 | 1 | 1 | 0 | 27.0270MHz | 27.0000MHz |
| 0 | 1 | 1 | 1 | 26.9730MHz | 26.9461MHz |
| 1 | 0 | 0 | 0 | 74.1758MHz | 74.1016MHz |
| 1 | 0 | 0 | 1 | 74.2500MHz | 74.1758MHz |
| 1 | 0 | 1 | 0 | 27.0000MHz | 26.9730MHz |
| 1 | 0 | 1 | 1 | 45.0000kHz | 44.9550kHz |
| 1 | 1 | 0 | 0 | 33.7500kHz | 33.7163kHz |
| 1 | 1 | 0 | 1 | 15.6250kHz | 15.6094kHz |
| 1 | 1 | 1 | 0 | 15.7343kHz | 15.7185kHz |
| 1 | 1 | 1 | 1 | 28.1250kHz | 28.0969kHz |

Table 3C. Output Frequency Table (dual PLL Mode)

| f_{VCXO} | FemtoClock Look-up Table | | | Output Frequency f_Q (MHz) |
|------------|--------------------------|----|----|------------------------------|
| | MF | N1 | N0 | |
| 27MHz | 0 | 0 | 0 | 148.5000 |
| | 0 | 0 | 1 | 74.2500 |
| | 0 | 1 | 0 | 49.5000 |
| | 0 | 1 | 1 | 33.0000 |
| | 1 | 0 | 0 | 162.0000 |
| | 1 | 0 | 1 | 81.0000 |
| | 1 | 1 | 0 | 54.0000 |
| | 1 | 1 | 1 | 36.0000 |
| 26.973MHz | 0 | 0 | 0 | 148.3515 |
| | 0 | 0 | 1 | 74.1758 |
| | 0 | 1 | 0 | 49.4505 |
| | 0 | 1 | 1 | 32.9670 |
| | 1 | 0 | 0 | 161.8380 |
| | 1 | 0 | 1 | 80.9190 |
| | 1 | 1 | 0 | 53.9460 |
| | 1 | 1 | 1 | 35.9640 |

NOTE: Use the VCXO-PLL mode to achieve output Frequencies of 27MHz or 26.973MHz. See Table 3H.

Table 3D. CLK_SEL Function Table

| Input | Operation |
|-------------|--------------------------------------|
| CLK_SEL | |
| 0 (default) | Selects CLK0 as PLL reference input. |
| 1 | Selects CLK1 as PLL reference input. |

Table 3E. MR Master Reset Function Table

| Input | Operation |
|-------------|--|
| MR | |
| 0 (default) | Normal operation, internal dividers and the output Q are enabled. |
| 1 | Internal dividers are reset. Q output is in logic low state (with OE = 1). |

Table 3F. FemtoClock PLL Feedback Divider Function Table

| Input | Operation |
|-------------|--|
| MF | |
| 0 (default) | Selects MF = 22. The 2nd stage PLL (FemtoClock, multiplies the output frequency of the VCXO-PLL by 22. |
| 1 | Selects MF = 24. The 2nd stage PLL (FemtoClock, multiplies the output frequency of the VCXO-PLL by 24. |

Table 3G. PLL Output Divider Function Table

| Input | | Operation |
|-------------|-------------|------------------------|
| N1 | N0 | |
| 0 (default) | 0 (default) | Output divider N = 4. |
| 0 | 1 | Output divider N = 8. |
| 1 | 0 | Output divider N = 12. |
| 1 | 1 | Output divider N = 18. |

Table 3H. PLL BYPASS Logic Function Table

| Input | | Operation |
|-------------|-------------|---|
| nBP1 | nBP0 | |
| 0 | 0 | VCXO-PLL mode: The input reference frequency is divided by the pre-divider P and is multiplied by the VCXO-PLL. $f_{OUT} = (f_{REF} \div P) * M$. |
| 0 | 1 | Test mode: The input reference frequency is divided by the pre-divider P and the output divider N and bypasses both PLLs. $f_{OUT} = f_{REF} \div (P * N)$. |
| 1 | 0 | FemtoClock Mode: The input reference frequency is divided by the pre-divider P multiplied by the 2 nd PLL (FemtoClock, MF). The 1 st PLL (VCXO-PLL, M) is bypassed. This mode does not support jitter attenuation. $f_{OUT} = (f_{REF} \div P) * MF \div N$. |
| 1 (default) | 1 (default) | Dual PLL Mode: both PLLs are cascaded for jitter attenuation and frequency multiplication. $f_{OUT} = (f_{REF} \div P) * M * MF \div N$. |

Absolute Maximum Ratings

NOTE: Stresses beyond those listed under *Absolute Maximum Ratings* may cause permanent damage to the device. These ratings are stress specifications only. Functional operation of product at these conditions or any conditions beyond those listed in the *DC Characteristics* or *AC Characteristics* is not implied. Exposure to absolute maximum rating conditions for extended periods may affect product reliability.

| Item | Rating |
|--|--|
| Supply Voltage, V_{DD} | 4.6V |
| Inputs, V_I XTAL_IN Other Inputs | 0V to V_{DD} -0.5V to $V_{DD} + 0.5V$ |
| Outputs, V_O | -0.5V to $V_{DDO} + 0.5V$ |
| Package Thermal Impedance, θ_{JA} | 37°C/W (0 mps) |
| Storage Temperature, T_{STG} | -65°C to 150°C |

DC Electrical Characteristics

Table 4A. Power Supply DC Characteristics, $V_{DD} = V_{DDO} = V_{DDX} = 3.3V \pm 5\%$, $T_A = 0^\circ\text{C}$ to 70°C

| Symbol | Parameter | Test Conditions | Minimum | Typical | Maximum | Units |
|-----------|----------------------------|-----------------|-----------------|---------|----------|-------|
| V_{DD} | Core Supply Voltage | | 3.135 | 3.3 | 3.465 | V |
| V_{DDA} | Analog Supply Voltage | | $V_{DD} - 0.15$ | 3.3 | V_{DD} | V |
| V_{DDO} | Output Supply Voltage | | 3.135 | 3.3 | 3.465 | V |
| V_{DDX} | Charge Pump Supply Voltage | | $V_{DD} - 0.04$ | 3.3 | 3.465 | V |
| I_{DD} | Power Supply Current | | | | 290 | mA |
| I_{DDA} | Analog Supply Current | | | | 15 | mA |
| I_{DDO} | Output Supply Current | No Load | | | 4 | mA |
| I_{DDX} | Charge Pump Supply Current | | | | 4 | mA |

Table 4B. LVCMOS/LVTTL DC Characteristics, $V_{DD} = V_{DDO} = V_{DDX} = 3.3V \pm 5\%$, $T_A = 0^\circ C$ to $70^\circ C$

| Symbol | Parameter | Test Conditions | Minimum | Typical | Maximum | Units |
|----------|---------------------|---|--------------------------------|---------|----------------|---------|
| V_{IH} | Input High Voltage | | 2.0 | | $V_{DD} + 0.3$ | V |
| V_{IL} | Input Low Voltage | | -0.3 | | 0.8 | V |
| I_{IH} | Input High Current | CLK[0:1], CLK_SEL, P[1:0], V[3:0], N[1:0], MR, MF, XTAL_SEL | $V_{DD} = V_{IN} = 3.465V$ | | 150 | μA |
| | | OE, nBP0, nBP1 | $V_{DD} = V_{IN} = 3.465V$ | | 5 | μA |
| I_{IL} | Input Low Current | CLK[0:1], CLK_SEL, P[1:0], V[3:0], N[1:0], MR, MF, XTAL_SEL | $V_{DD} = 3.465V, V_{IN} = 0V$ | | -5 | μA |
| | | OE, nBP0, nBP1 | $V_{DD} = 3.465, V_{IN} = 0V$ | | -150 | μA |
| V_{OH} | Output High Voltage | $I_{OH} = -24mA$ | 2.6 | | | V |
| V_{OL} | Output Low Voltage | $I_{OL} = 24mA$ | | | 0.5 | V |

AC Electrical Characteristics

Table 5. AC Characteristics, $V_{DD} = V_{DDO} = V_{DDX} = 3.3V \pm 5\%$, $T_A = 0^\circ C$ to $70^\circ C$

| Symbol | Parameter | Test Conditions | Minimum | Typical | Maximum | Units |
|----------------------|---|---|---------|---------|---------|-------|
| f_{OUT} | Output Frequency | nBP0, nBP1 = 00 | 14 | | 35 | MHz |
| | | nBP1 = 1 | 31 | | 175 | MHz |
| $f_{jit}(\emptyset)$ | RMS Phase Jitter, (Random), NOTE 1 | 148.3516MHz, Integration Range: 12kHz – 20MHz | | 1.089 | | ps |
| t_R / t_F | Output Rise/Fall Time | 20% to 80% | 250 | | 750 | ps |
| odc | Output Duty Cycle | | 48 | | 52 | % |
| t_{LOCK} | VCXO & FemtoClock PLL Lock Time; NOTE 2 | M = 92, Bandwidth = 475Hz | | 100 | | ms |
| | | M = 4004, Bandwidth = 6Hz | | 25 | | s |

NOTE: Electrical parameters are guaranteed over the specified ambient operating temperature range, which is established when the device is mounted in a test socket with maintained transverse airflow greater than 500 lfm. The device will meet specifications after thermal equilibrium has been reached under these conditions.

See Parameter Measurement Information Section.

NOTE 1: Refer to the Phase Noise Plot.

NOTE 2: Lock Time measured from power-up to stable output frequency.

Typical Phase Noise at 148.3516MHz

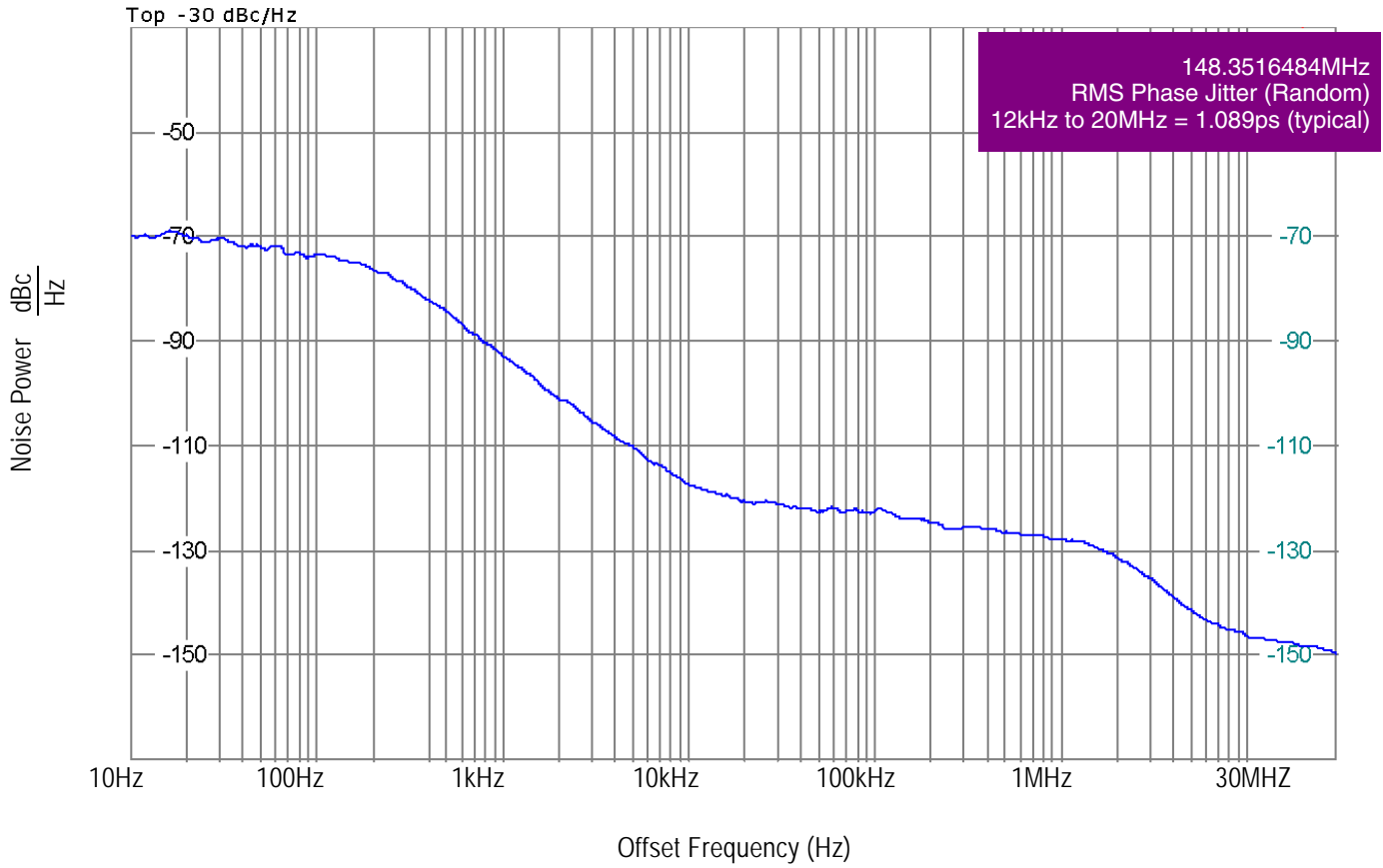

Parameter Measurement Information

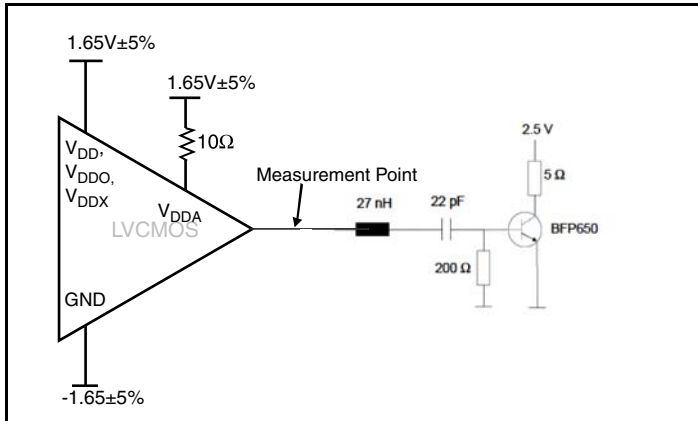

3.3V Output Load AC Test Circuit

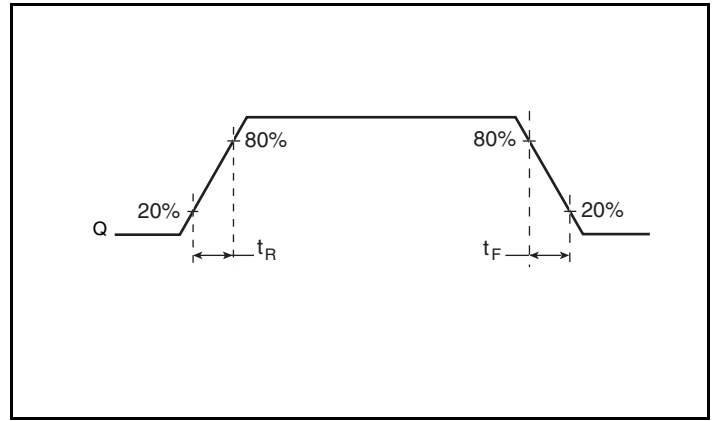

Output Rise/Fall Time

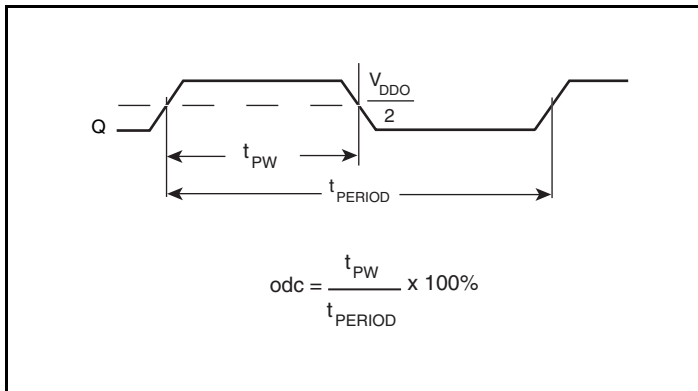

Output Duty Cycle/Pulse Width/Period

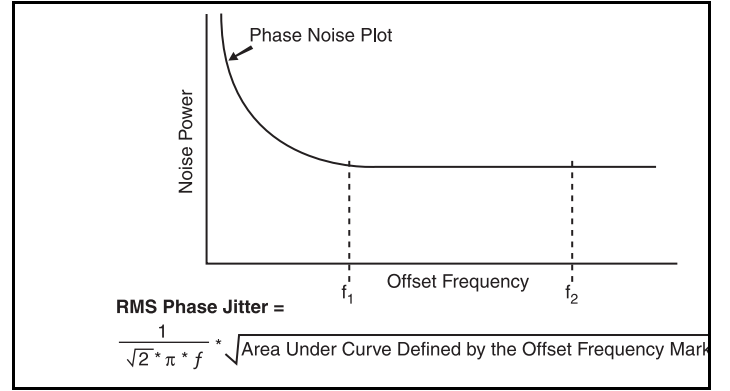

Phase Jitter

Applications Information

Recommendations for Unused Input Pins

Inputs:

CLK Inputs

For applications not requiring the use of a clock input, it can be left floating. Though not required, but for additional protection, a $1k\Omega$ resistor can be tied from the CLK input to ground.

LVC MOS Control Pins

All control pins have internal pullups or pulldowns; additional resistance is not required but can be added for additional protection. A $1k\Omega$ resistor can be used.

Power Supply Filtering Technique

As in any high speed analog circuitry, the power supply pins are vulnerable to random noise. To achieve optimum jitter performance, power supply isolation is required. The 810001-21 provides separate power supplies to isolate any high switching noise from the outputs to the internal PLL. V_{DD} , V_{DDA} , V_{DDO} and V_{DDX} should be individually connected to the power supply plane through vias, and $0.01\mu\text{F}$ bypass capacitors should be used for each pin. *Figure 1* illustrates this for a generic V_{DD} pin and also shows that V_{DDA} requires that an additional 10Ω resistor along with a $10\mu\text{F}$ bypass capacitor be connected to the V_{DDA} pin.

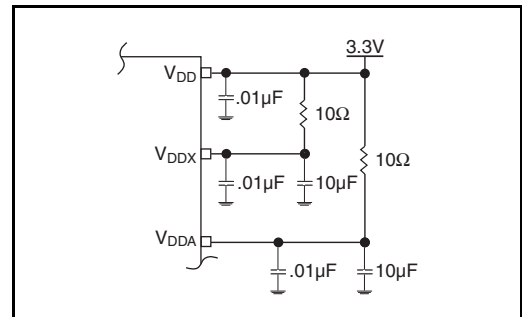

Figure 1. Power Supply Filtering

VFQFN EPAD Thermal Release Path

In order to maximize both the removal of heat from the package and the electrical performance, a land pattern must be incorporated on the Printed Circuit Board (PCB) within the footprint of the package corresponding to the exposed metal pad or exposed heat slug on the package, as shown in *Figure 2*. The solderable area on the PCB, as defined by the solder mask, should be at least the same size/shape as the exposed pad/slug area on the package to maximize the thermal/electrical performance. Sufficient clearance should be designed on the PCB between the outer edges of the land pattern and the inner edges of pad pattern for the leads to avoid any shorts.

While the land pattern on the PCB provides a means of heat transfer and electrical grounding from the package to the board through a solder joint, thermal vias are necessary to effectively conduct from the surface of the PCB to the ground plane(s). The land pattern must be connected to ground through these vias. The vias act as “heat pipes”. The number of vias (i.e. “heat pipes”) are application specific and dependent upon the package power dissipation as well as

electrical conductivity requirements. Thus, thermal and electrical analysis and/or testing are recommended to determine the minimum number needed. Maximum thermal and electrical performance is achieved when an array of vias is incorporated in the land pattern. It is recommended to use as many vias connected to ground as possible. It is also recommended that the via diameter should be 12 to 13mils (0.30 to 0.33mm) with 1oz copper via barrel plating. This is desirable to avoid any solder wicking inside the via during the soldering process which may result in voids in solder between the exposed pad/slug and the thermal land. Precautions should be taken to eliminate any solder voids between the exposed heat slug and the land pattern. Note: These recommendations are to be used as a guideline only. For further information, please refer to the Application Note on the Surface Mount Assembly of Amkor’s Thermally/Electrically Enhance Leadframe Base Package, Amkor Technology.

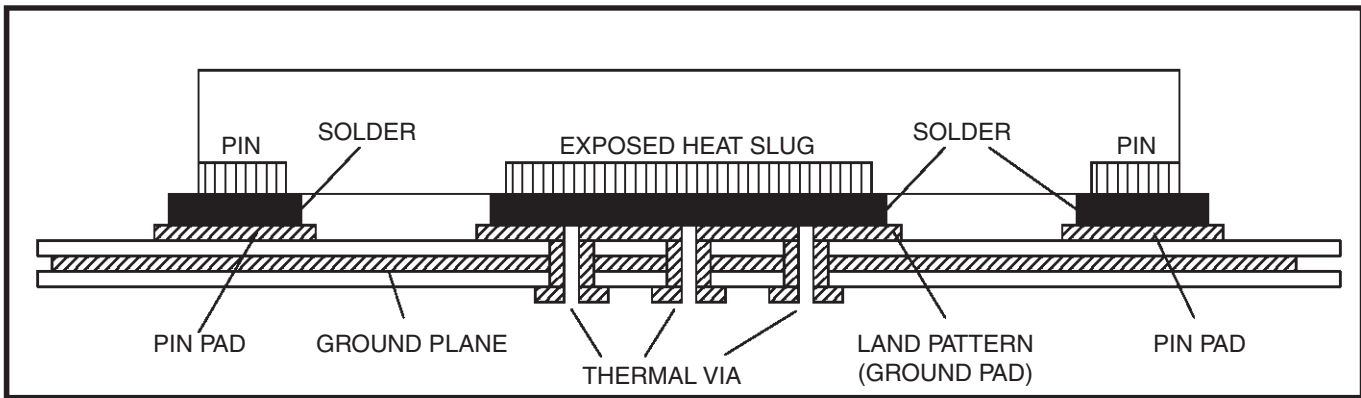

Figure 2. P.C. Assembly for Exposed Pad Thermal Release Path – Side View (drawing not to scale)

Schematic Example

Figure 3 shows an example of the 810001-21 application schematic. In this example, the device is operated at $V_{DD} = V_{DDX} = V_{DDO} = V_{DDA} = 3.3V$. The decoupling capacitors should be located as close as possible to the power pin. The input is driven by a 3.3V 17Ω LVC MOS driver. An optional 3-pole filter can also be used for additional spur reduction. It is recommended that the loop filter

components be laid out for the 3-pole option. This will also allow the 2-pole filter to be used. For the LVC MOS output, a termination example is shown in this schematic. For more termination approaches, please refer to the LVC MOS Termination Application Note.

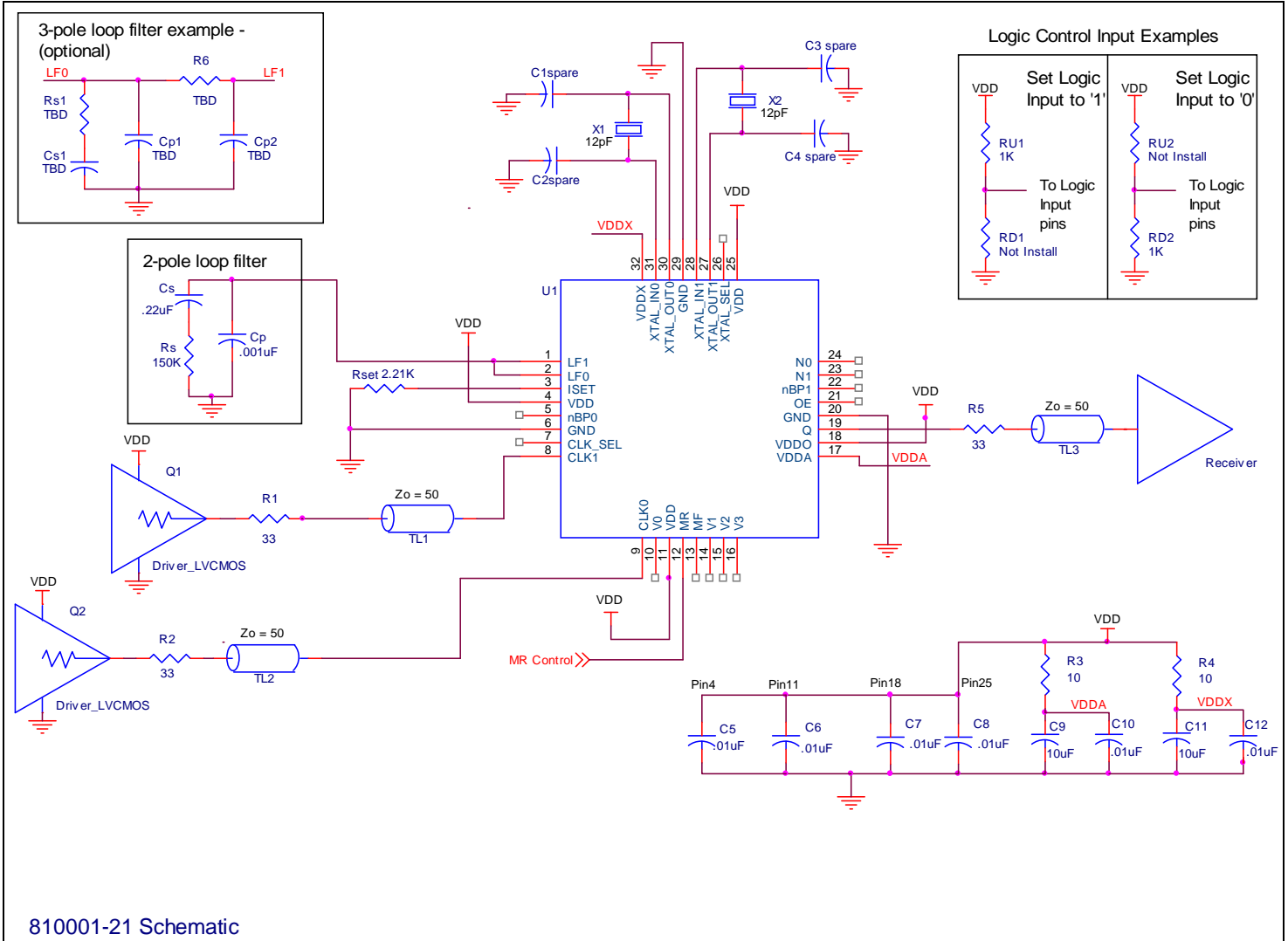

Figure 3. 810001-21 Schematic Example

VCXO-PLL EXTERNAL COMPONENTS

Choosing the correct external components and having a proper printed circuit board (PCB) layout is a key task for quality operation of the VCXO-PLL. In choosing a crystal, special precaution must be taken with the package and load capacitance (C_L). In addition, frequency, accuracy and temperature range must also be considered. Since the pulling range of a crystal also varies with the package, it is recommended that a metal-canned package like HC49 be used. Generally, a metal-canned package has a larger pulling range than a surface mounted device (SMD). For crystal selection information, refer to the *VCXO Crystal Selection Application Note*.

The crystal's load capacitance C_L characteristic determines its resonating frequency and is closely related to the VCXO tuning range. The total external capacitance seen by the crystal when installed on a board is the sum of the stray board capacitance, IC package lead capacitance, internal varactor capacitance and any installed tuning capacitors (C_{TUNE}).

If the crystal C_L is greater than the total external capacitance, the VCXO will oscillate at a higher frequency than the crystal specification. If the crystal C_L is lower than the total external capacitance, the VCXO will oscillate at a lower frequency than the crystal specification. In either case, the absolute tuning range is reduced. The correct value of C_L is dependent on the characteristics of the VCXO. The recommended C_L in the Crystal Parameter Table balances the tuning range by centering the tuning curve.

The frequency of oscillation in the third overtone mode is not necessarily at exactly three times the fundamental frequency. The mechanical properties of the quartz element dictate the position of the overtones relative to the fundamental. The oscillator circuit may excite both the fundamental and overtone modes simultaneously. This will cause a nonlinearity in the tuning curve.

This potential problem is why VCXO crystals are required to be tested for absence of any activity inside a ± 200 ppm window at three times the fundamental frequency. Refer to F_{L_3OVT} and $F_{L_3OVT_spurs}$ in the crystal Characteristics table.

The crystal and external loop filter components should be kept as close as possible to the device. Loop filter and crystal traces should be kept short and separated from each other. Other signal traces should be kept separate and not run underneath the device, loop filter or crystal components.

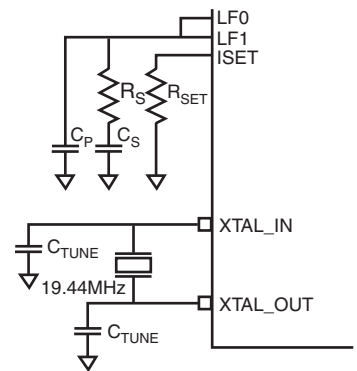

VCXO Characteristics Table

| Symbol | Parameter | Typical | Units |
|---------------|---------------------------|---------|-------|
| k_{VCXO} | VCXO Gain | 6.6 | kHz/V |
| C_{V_LOW} | Low Varactor Capacitance | 15 | pF |
| C_{V_HIGH} | High Varactor Capacitance | 29 | pF |

VCXO-PLL Loop Bandwidth Selection Table

| Bandwidth | Crystal Frequency (MHz) | M | R_S (k Ω) | C_S (μ F) | C_P (μ F) | R_{SET} (k Ω) |
|--------------|-------------------------|------|---------------------|------------------|------------------|-------------------------|
| 6Hz (Low) | 27 | 4004 | 175 | 4.7 | 0.01 | 8.0 |
| 80Hz (Mid) | 27 | 1000 | 150 | 0.22 | 0.001 | 2.21 |
| 475Hz (High) | 27 | 92 | 125 | 0.1 | 0.0001 | 3.3 |

Crystal Characteristics

| Symbol | Parameter | Test Conditions | Minimum | Typical | Maximum | Units |
|---------------------------------|---|-----------------|-------------|---------|-------------|-------|
| | Mode of Oscillation | | Fundamental | | | |
| f _N | Frequency | | | 27 | | MHz |
| | | | | 26.973 | | MHz |
| f _T | Frequency Tolerance | | | | ±20 | ppm |
| f _S | Frequency Stability | | | | ±20 | ppm |
| | Operating Temperature Range | | 0 | | 70 | °C |
| C _L | Load Capacitance | | | 12 | | pF |
| C _O | Shunt Capacitance | | | 4 | | pF |
| C _O / C ₁ | Pullability Ratio | | | 220 | 240 | |
| F _{L_3OVT} | 3 RD Overtone F _L | | 200 | | | ppm |
| F _{L_3OVT_spurs} | 3 RD Overtone F _L Spurs | | 200 | | | ppm |
| ESR | Equivalent Series Resistance | | | | 20 | Ω |
| | Drive Level | | | | 1 | mW |
| | Aging @ 25 °C | | | | ±3 per year | ppm |

Reliability Information

Table 6. θ_{JA} vs. Air Flow Table for a 32 Lead VFQFN

| θ_{JA} vs. Air Flow | | | |
|---|----------|----------|--------|
| Meters per Second | 0 | 1 | 2.5 |
| Multi-Layer PCB, JEDEC Standard Test Boards | 37.0°C/W | 32.4°C/W | 29°C/W |

Transistor Count

The transistor count for 810001-21 is: 9365

Package Outline and Package Dimensions

Package Outline - K Suffix for 32 Lead VFQFN

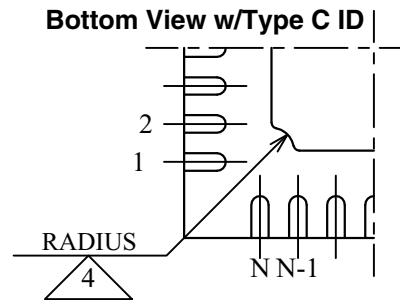
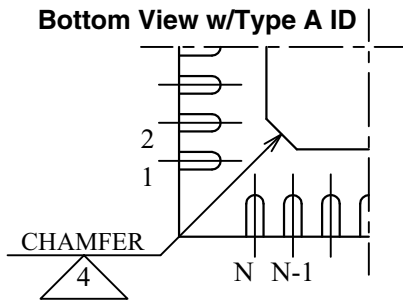
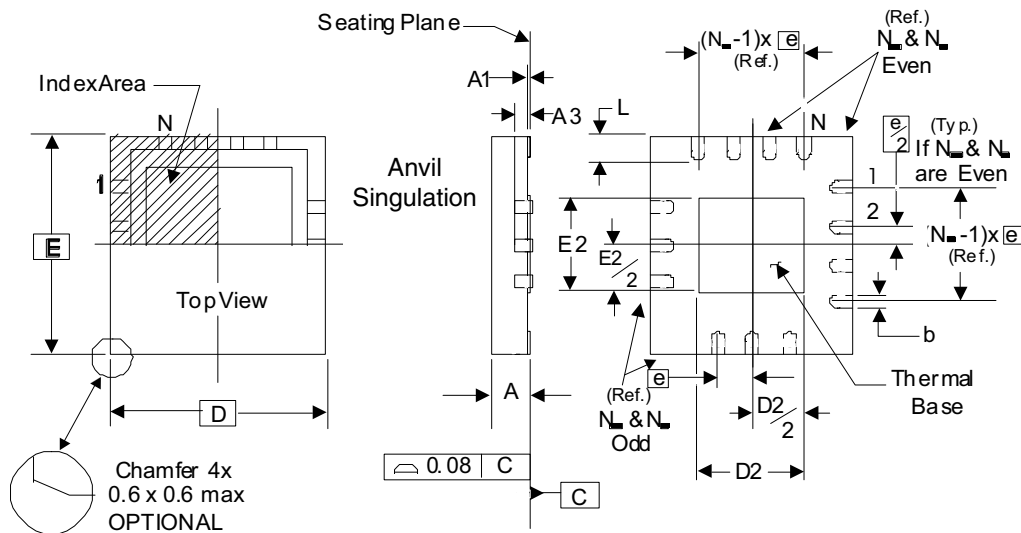

There are 2 methods of indicating pin 1 corner at the back of the VFQFN package:

1. Type A: Chamfer on the paddle (near pin 1)
2. Type C: Mouse bite on the paddle (near pin 1)

Table 7. Package Dimensions

| JEDEC Variation: VHHD-2/-4 | | | |
|-------------------------------|------------|---------|---------|
| All Dimensions in Millimeters | | | |
| Symbol | Minimum | Nominal | Maximum |
| N | 32 | | |
| A | 0.80 | | 1.00 |
| A1 | 0 | | 0.05 |
| A3 | 0.25 Ref. | | |
| b | 0.18 | 0.25 | 0.30 |
| $N_D \& N_E$ | | | 8 |
| D & E | 5.00 Basic | | |
| D2 & E2 | 3.0 | | 3.3 |
| e | 0.50 Basic | | |
| L | 0.30 | 0.40 | 0.50 |

Reference Document: JEDEC Publication 95, MO-220

NOTE: The following package mechanical drawing is a generic drawing that applies to any pin count VFQFN package. This drawing is not intended to convey the actual pin count or pin layout of this device. The pin count and pinout are shown on the front page. The package dimensions are in Table 7.

Ordering Information

Table 8. Ordering Information

| Part/Order Number | Marking | Package | Shipping Packaging | Temperature |
|-------------------|-------------|---------------------------|--------------------|-------------|
| 810001DK-21LF | ICS0001D21L | "Lead-Free" 32 Lead VFQFN | Tray | 0°C to 70°C |
| 810001DK-21LFT | ICS0001D21L | "Lead-Free" 32 Lead VFQFN | Tape & Reel | 0°C to 70°C |

Revision History Sheet

| Rev | Table | Page | Description of Change | Date |
|-----|-------|---------------------------|--|---------|
| B | T4B | 8 10 14 15 16 | LVMOS DC Characteristics Table - corrected typo in V_{IH} row from 3V min. to 2V min. Parameter Measurement Information - updated 3.3V Load AC Test Circuit Diagram. Replaced 4th paragraph in <i>VCXO-PLL External Components</i> section. Crystal Characteristics Table - added 3rd Overtone specs. Updated VFQFN Package Outline. Updated datasheet Header/Footer. | 4/13/10 |
| B | T8 | 17 | Ordering Information - Removed leaded devices. Updated data sheet format | 4/23/15 |
| B | T8 | 17 | Ordering Information - Deleted LF note below table. Removed quantity from tape and reel. Updated data sheet header and footer. | 3/3/16 |

IMPORTANT NOTICE AND DISCLAIMER

RENESAS ELECTRONICS CORPORATION AND ITS SUBSIDIARIES (“RENESAS”) PROVIDES TECHNICAL SPECIFICATIONS AND RELIABILITY DATA (INCLUDING DATASHEETS), DESIGN RESOURCES (INCLUDING REFERENCE DESIGNS), APPLICATION OR OTHER DESIGN ADVICE, WEB TOOLS, SAFETY INFORMATION, AND OTHER RESOURCES “AS IS” AND WITH ALL FAULTS, AND DISCLAIMS ALL WARRANTIES, EXPRESS OR IMPLIED, INCLUDING, WITHOUT LIMITATION, ANY IMPLIED WARRANTIES OF MERCHANTABILITY, FITNESS FOR A PARTICULAR PURPOSE, OR NON-INFRINGEMENT OF THIRD-PARTY INTELLECTUAL PROPERTY RIGHTS.

These resources are intended for developers who are designing with Renesas products. You are solely responsible for (1) selecting the appropriate products for your application, (2) designing, validating, and testing your application, and (3) ensuring your application meets applicable standards, and any other safety, security, or other requirements. These resources are subject to change without notice. Renesas grants you permission to use these resources only to develop an application that uses Renesas products. Other reproduction or use of these resources is strictly prohibited. No license is granted to any other Renesas intellectual property or to any third-party intellectual property. Renesas disclaims responsibility for, and you will fully indemnify Renesas and its representatives against, any claims, damages, costs, losses, or liabilities arising from your use of these resources. Renesas' products are provided only subject to Renesas' Terms and Conditions of Sale or other applicable terms agreed to in writing. No use of any Renesas resources expands or otherwise alters any applicable warranties or warranty disclaimers for these products.

(Disclaimer Rev.1.01)

Corporate Headquarters

TOYOSU FORESIA, 3-2-24 Toyosu,
Koto-ku, Tokyo 135-0061, Japan
www.renesas.com

Trademarks

Renesas and the Renesas logo are trademarks of Renesas Electronics Corporation. All trademarks and registered trademarks are the property of their respective owners.

Contact Information

For further information on a product, technology, the most up-to-date version of a document, or your nearest sales office, please visit www.renesas.com/contact-us/.