



**16-Channel  
Short Haul E1  
Line Interface Unit  
IDT82P20516**

**Version -  
December 17, 2009**

6024 Silver Creek Valley Road, San Jose, California 95138  
Telephone: 1-800-345-7015 or 408-284-8200 • TWX: 910-338-2070 • FAX: 408-284-2775  
Printed in U.S.A.  
© 2009 Integrated Device Technology, Inc.

#### DISCLAIMER

Integrated Device Technology, Inc. reserves the right to make changes to its products or specifications at any time, without notice, in order to improve design or performance and to supply the best possible product. IDT does not assume any responsibility for use of any circuitry described other than the circuitry embodied in an IDT product. The Company makes no representations that circuitry described herein is free from patent infringement or other rights of third parties which may result from its use. No license is granted by implication or otherwise under any patent, patent rights or other rights, of Integrated Device Technology, Inc.

#### LIFE SUPPORT POLICY

Integrated Device Technology's products are not authorized for use as critical components in life support devices or systems unless a specific written agreement pertaining to such intended use is executed between the manufacturer and an officer of IDT.

1. Life support devices or systems are devices or systems which (a) are intended for surgical implant into the body or (b) support or sustain life and whose failure to perform, when properly used in accordance with instructions for use provided in the labeling, can be reasonably expected to result in a significant injury to the user.
2. A critical component is any components of a life support device or system whose failure to perform can be reasonably expected to cause the failure of the life support device or system, or to affect its safety or effectiveness.



# Table of Contents

TABLE OF CONTENTS .....	3
LIST OF TABLES .....	6
LIST OF FIGURES .....	7
FEATURES .....	8
APPLICATIONS.....	9
DESCRIPTION.....	9
BLOCK DIAGRAM .....	10
1 PIN ASSIGNMENT .....	11
2 PIN DESCRIPTION .....	12
3 FUNCTIONAL DESCRIPTION .....	19
3.1 E1 MODE SELECTION .....	19
3.2 RECEIVE PATH .....	19
3.2.1 Rx Termination .....	19
3.2.1.1 Receive Differential Mode .....	19
3.2.2 Equalizer .....	20
3.2.2.1 Line Monitor .....	21
3.2.2.2 Receive Sensitivity .....	21
3.2.3 Slicer .....	22
3.2.4 Rx Clock & Data Recovery .....	22
3.2.5 Decoder .....	22
3.2.6 Receive System Interface .....	22
3.2.7 Receiver Power Down .....	23
3.3 TRANSMIT PATH .....	23
3.3.1 Transmit System Interface .....	23
3.3.2 Tx Clock Recovery .....	24
3.3.3 Encoder .....	24
3.3.4 Waveform Shaper .....	24
3.3.4.1 Preset Waveform Template .....	24
3.3.4.2 User-Programmable Arbitrary Waveform .....	25
3.3.5 Line Driver .....	27
3.3.5.1 Transmit Over Current Protection .....	27
3.3.6 Tx Termination .....	27
3.3.6.1 Transmit Differential Mode .....	27
3.3.7 Transmitter Power Down .....	29
3.3.8 Output High-Z on TTIP and TRING .....	29
3.4 JITTER ATTENUATOR (RJA & TJA) .....	30
3.5 DIAGNOSTIC FACILITIES .....	31
3.5.1 Bipolar Violation (BPV) / Code Violation (CV) Detection and BPV Insertion .....	31

3.5.1.1	Bipolar Violation (BPV) / Code Violation (CV) Detection .....	31
3.5.1.2	Bipolar Violation (BPV) Insertion .....	31
3.5.2	Excessive Zeroes (EXZ) Detection .....	31
3.5.3	Loss of Signal (LOS) Detection .....	32
3.5.3.1	Line LOS (LLOS) .....	32
3.5.3.2	System LOS (SLOS) .....	33
3.5.3.3	Transmit LOS (TLOS) .....	34
3.5.4	Alarm Indication Signal (AIS) Detection and Generation .....	35
3.5.4.1	Alarm Indication Signal (AIS) Detection .....	35
3.5.4.2	(Alarm Indication Signal) AIS Generation .....	35
3.5.5	PRBS, QRSS, ARB and IB Pattern Generation and Detection .....	36
3.5.5.1	Pattern Generation .....	36
3.5.5.2	Pattern Detection .....	37
3.5.6	Error Counter .....	38
3.5.6.1	Automatic Error Counter Updating .....	38
3.5.6.2	Manual Error Counter Updating .....	39
3.5.7	Loopback .....	40
3.5.7.1	Analog Loopback .....	40
3.5.7.2	Remote Loopback .....	41
3.5.7.3	Digital Loopback .....	42
3.5.8	Channel 0 Monitoring .....	43
3.5.8.1	G.772 Monitoring .....	43
3.5.8.2	Jitter Measurement (JM) .....	44
3.6	CLOCK INPUTS AND OUTPUTS .....	45
3.6.1	Free Running Clock Outputs on CLKE1 .....	45
3.6.2	MCLK, Master Clock Input .....	46
3.6.3	XCLK, Internal Reference Clock Input .....	46
3.7	INTERRUPT SUMMARY .....	47
<b>4</b>	<b>MISCELLANEOUS .....</b>	<b>49</b>
4.1	RESET .....	49
4.1.1	Power-On Reset .....	50
4.1.2	Hardware Reset .....	50
4.1.3	Global Software Reset .....	50
4.1.4	Per-Channel Software Reset .....	50
4.2	MICROPROCESSOR INTERFACE .....	50
4.3	POWER UP .....	51
4.4	HITLESS PROTECTION SWITCHING (HPS) SUMMARY .....	51
<b>5</b>	<b>PROGRAMMING INFORMATION .....</b>	<b>54</b>
5.1	REGISTER MAP .....	54
5.1.1	Global Register .....	54
5.1.2	Per-Channel Register .....	55
5.2	REGISTER DESCRIPTION .....	58
5.2.1	Global Register .....	58
5.2.2	Per-Channel Register .....	62

**6 JTAG ..... 92**

6.1 JTAG INSTRUCTION REGISTER (IR) ..... 92

6.2 JTAG DATA REGISTER ..... 92

    6.2.1 Device Identification Register (IDR) ..... 92

    6.2.2 Bypass Register (BYP) ..... 92

    6.2.3 Boundary Scan Register (BSR) ..... 92

6.3 TEST ACCESS PORT (TAP) CONTROLLER ..... 92

**7 THERMAL MANAGEMENT ..... 94**

7.1 JUNCTION TEMPERATURE ..... 94

7.2 EXAMPLE OF JUNCTION TEMPERATURE CALCULATION ..... 94

7.3 HEATSINK EVALUATION ..... 94

**8 PHYSICAL AND ELECTRICAL SPECIFICATIONS ..... 95**

8.1 ABSOLUTE MAXIMUM RATINGS ..... 95

8.2 RECOMMENDED OPERATING CONDITIONS ..... 96

8.3 DEVICE POWER CONSUMPTION AND DISSIPATION (TYPICAL) 1 ..... 97

8.4 DEVICE POWER CONSUMPTION AND DISSIPATION (MAXIMUM) 1 ..... 98

8.5 D.C. CHARACTERISTICS ..... 99

8.6 E1 RECEIVER ELECTRICAL CHARACTERISTICS ..... 100

8.7 E1 TRANSMITTER ELECTRICAL CHARACTERISTICS ..... 102

8.8 TRANSMITTER AND RECEIVER TIMING CHARACTERISTICS ..... 103

8.9 CLKE1 TIMING CHARACTERISTICS ..... 105

8.10 JITTER ATTENUATION CHARACTERISTICS ..... 106

8.11 MICROPROCESSOR INTERFACE TIMING ..... 108

    8.11.1 Serial Microprocessor Interface ..... 108

8.12 JTAG TIMING CHARACTERISTICS ..... 110

**GLOSSARY ..... 111**

**INDEX ..... 113**

**ORDERING INFORMATION ..... 115**



# List of Tables

---

Table-1	Operation Mode Selection .....	19
Table-2	Impedance Matching Value in Receive Differential Mode .....	20
Table-3	Multiplex Pin Used in Receive System Interface .....	22
Table-4	Multiplex Pin Used in Transmit System Interface .....	24
Table-5	PULS[3:0] Setting in E1 Mode .....	25
Table-6	Transmit Waveform Value for E1 75 ohm .....	26
Table-7	Transmit Waveform Value for E1 120 ohm .....	26
Table-8	Impedance Matching Value in Transmit Differential Mode .....	27
Table-9	EXZ Definition .....	31
Table-10	LLOS Criteria .....	32
Table-11	SLOS Criteria .....	33
Table-12	TLOS Detection Between Two Channels .....	34
Table-13	AIS Criteria .....	35
Table-14	Clock Output on CLKE1 .....	45
Table-15	Interrupt Summary .....	47
Table-16	After Reset Effect Summary .....	49



# List of Figures

Figure-1	Functional Block Diagram	10
Figure-2	484-Pin Fine Pitch BGA (Top View)	11
Figure-3	Switch between Impedance Matching Modes	19
Figure-4	Receive Differential Line Interface with Twisted Pair Cable (with transformer)	20
Figure-5	Receive Differential Line Interface with Coaxial Cable (with transformer)	20
Figure-6	Receive Differential Line Interface with Twisted Pair Cable (transformer-less, non standard compliant)	20
Figure-7	Receive Path Monitoring	21
Figure-8	Transmit Path Monitoring	21
Figure-9	E1 Waveform Template	24
Figure-10	E1 Waveform Template Measurement Circuit	24
Figure-11	Transmit Differential Line Interface with Twisted Pair Cable (with Transformer)	28
Figure-12	Transmit Differential Line Interface with Coaxial Cable (with transformer)	28
Figure-13	Transmit Differential Line Interface with Twisted Pair Cable (transformer-less, non standard compliant)	28
Figure-14	Jitter Attenuator	30
Figure-15	LLOS Indication on Pins	32
Figure-16	TLOS Detection Between Two Channels	34
Figure-17	Pattern Generation (1)	36
Figure-18	Pattern Generation (2)	36
Figure-19	PRBS / ARB Detection	37
Figure-20	IB Detection	38
Figure-21	Automatic Error Counter Updating	39
Figure-22	Manual Error Counter Updating	39
Figure-23	Priority Of Diagnostic Facilities During Analog Loopback	40
Figure-24	Priority Of Diagnostic Facilities During Manual Remote Loopback	41
Figure-25	Priority Of Diagnostic Facilities During Digital Loopback	42
Figure-26	G.772 Monitoring	43
Figure-27	Automatic JM Updating	44
Figure-28	Manual JM Updating	44
Figure-29	Interrupt Service Process	48
Figure-30	Reset	49
Figure-31	1+1 HPS Scheme, Differential Interface (Shared Common Transformer)	51
Figure-32	1:1 HPS Scheme, Differential Interface (Individual Transformer)	52
Figure-33	1+1 HPS Scheme, E1 75 ohm Single-Ended Interface (Shared Common Transformer)	53
Figure-34	JTAG Architecture	92
Figure-35	JTAG State Diagram	93
Figure-36	Transmit Clock Timing Diagram	104
Figure-37	Receive Clock Timing Diagram	104
Figure-38	CLKE1 Clock Timing Diagram	105
Figure-39	E1 Jitter Tolerance Performance	106
Figure-40	E1 Jitter Transfer Performance	107
Figure-41	Read Operation in Serial Microprocessor Interface	108
Figure-42	Write Operation in Serial Microprocessor Interface	108
Figure-43	Timing Diagram	109
Figure-44	JTAG Timing	110



## 16-Channel Short Haul E1 Line Inter- face Unit

**IDT82P20516**

### FEATURES

- ◆ **Integrates 16 channels E1 short haul line interface units for 120  $\Omega$  E1 twisted pair cable and 75  $\Omega$  E1 coaxial cable applications**
- ◆ **Per-channel configurable Line Interface options**
  - Fully integrated and software selectable receive and transmit termination
    - Option 1: Fully Internal Impedance Matching with integrated receive termination resistor
    - Option 2: Partially Internal Impedance Matching with common external resistor for improved device power dissipation
    - Option 3: External impedance Matching termination
  - Supports global configuration and per-channel configuration to E1 mode
- ◆ **Per-channel programmable features**
  - Provides E1 short haul waveform templates and user-programmable arbitrary waveform templates
  - Provides two JAs (Jitter Attenuator) for each channel of receiver and transmitter
  - Supports AMI/HDB3 (for E1) encoding and decoding
- ◆ **Per-channel System Interface options**
  - Supports Single Rail, Dual Rail with clock or without clock and sliced system interface
  - Integrated Clock Recovery for the transmit interface to recover transmit clock from system transmit data
- ◆ **Per-channel system and diagnostic functions**
  - Provides transmit driver over-current detection and protection with optional automatic high impedance of transmit interface
  - Detects and generates PRBS (Pseudo Random Bit Sequence), ARB (Arbitrary Pattern) and IB (Inband Loopback) in either receive or transmit direction
  - Provides defect and alarm detection in both receive and transmit directions.
    - Defects include BPV (Bipolar Violation) /CV (Code Violation) and EXZ (Excessive Zeroes)
    - Alarms include LLOS (Line LOS), SLOS (System LOS), TLOS (Transmit LOS) and AIS (Alarm Indication Signal)
  - Programmable LLOS detection /clear levels. Compliant with ITU and ANSI specifications
- Various pattern, defect and alarm reporting options
  - Serial hardware LLOS reporting (LLOS, LLOS0) for all 16 channels
  - Register access to individual registers or 16-bit error counters
- Supports Analog Loopback, Digital Loopback and Remote Loopback
- Supports line monitor
- ◆ **Hitless Protection Switching (HPS) without external Relays**
  - Supports 1+1 and 1:1 hitless protection switching
  - Asynchronous hardware control (OE, RIM) for fast global high impedance of receiver and transmitter (hot switching between working and backup board)
  - High impedance transmitter and receiver while powered down
  - Per-channel register control for high impedance, independent for receiver and transmitter
- ◆ **Clock Inputs and Outputs**
  - Flexible master clock ( $N \times 1.544$  MHz or  $N \times 2.048$  MHz) ( $1 \leq N \leq 8$ , N is an integer number)
  - Integrated clock synthesizer can multiply or divide the reference clock to a wide range of frequencies: 8 KHz, 64 KHz, 2.048 MHz, 4.096 MHz, 8.192 MHz, 19.44 MHz and 32.768 MHz
- ◆ **Microprocessor Interface**
  - Supports Serial microprocessor interface
- ◆ **Other Key Features**
  - IEEE1149.1 JTAG boundary scan
  - Two general purpose I/O pins
  - 3.3 V I/O with 5 V tolerant inputs
  - 3.3 V and 1.8 V power supply
  - Package: 484-pin Fine Pitch BGA (19 mm X 19 mm)
- ◆ **Applicable Standards**
  - Bellcore TR-TSY-000009, GR-253-CORE and GR-499-CORE
  - ETSI CTR12/13
  - ETS 300166 and ETS 300 233
  - G.703, G.735, G.736, G.742, G.772, G.775, G.783 and G.823
  - O.161



## APPLICATIONS

- ◆ SDH/SONET multiplexers
- ◆ Central office or PBX (Private Branch Exchange)
- ◆ Digital access cross connects
- ◆ Remote wireless modules
- ◆ Microwave transmission systems

## DESCRIPTION

The IDT82P20516 is a 16-channel high-density E1 short haul Line Interface Unit. Each channel of the IDT82P20516 can be independently configured. The configuration is performed through a Serial microprocessor interface.

In the receive path, through a Single Ended or Differential line interface, the received signal is processed by an adaptive Equalizer and then sent to a Slicer. Clock and data are recovered from the digital pulses output from the Slicer. After passing through an enabled or disabled Receive Jitter Attenuator, the recovered data is decoded using B8ZS/

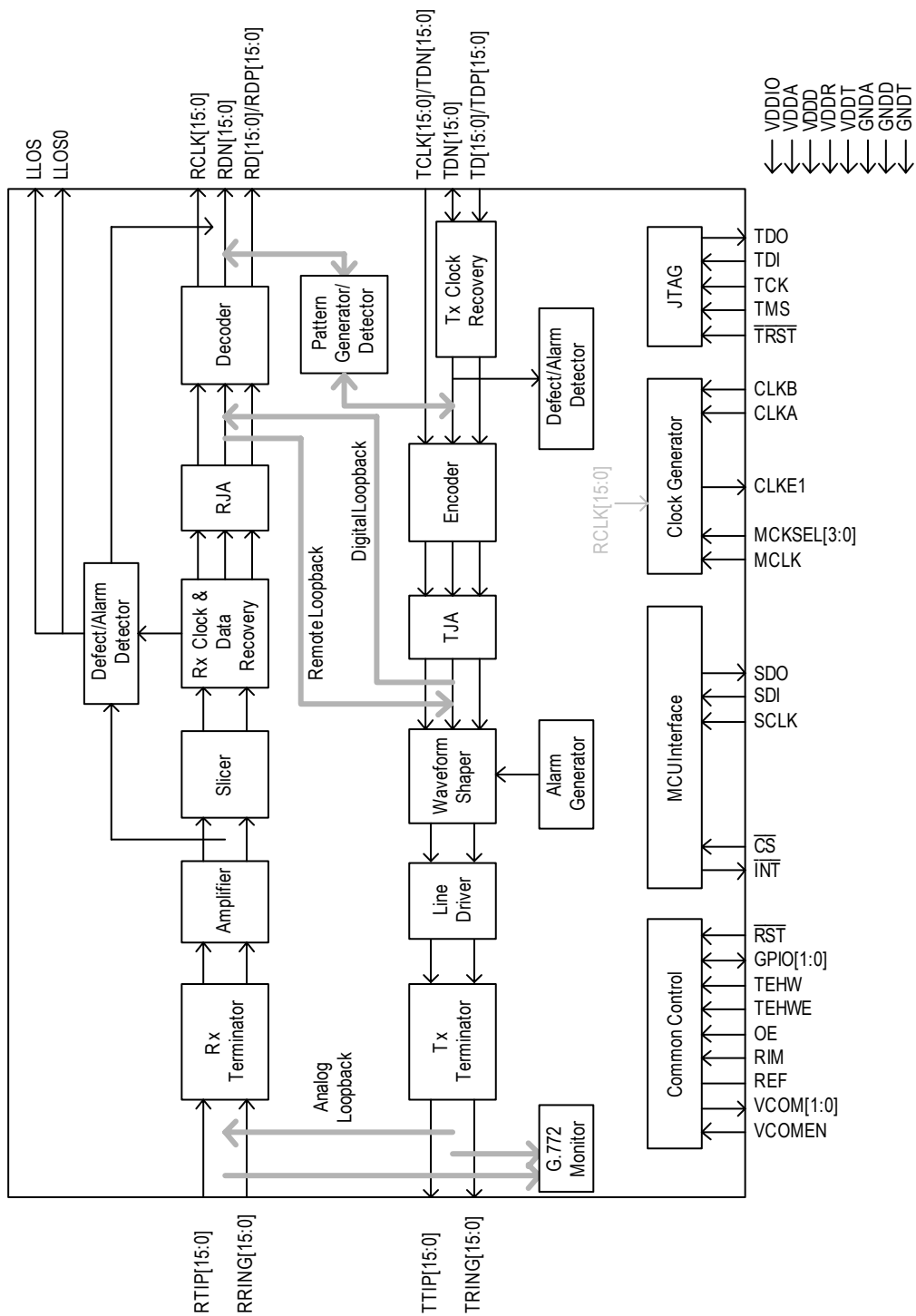
AMI/HDB3 line code rule in Single Rail NRZ Format mode and output to the system, or output to the system without decoding in Dual Rail NRZ Format mode and Dual Rail RZ Format mode.

In the transmit path, the data to be transmitted is input on TDn in Single Rail NRZ Format mode or TDPn/TDNn in Dual Rail NRZ Format mode and Dual Rail RZ Format mode, and is sampled by a transmit reference clock. The clock can be supplied externally from TCLKn or recovered from the input transmit data by an internal Clock Recovery. A selectable JA in Tx path is used to de-jitter gapped clocks. To meet E1 waveform standards, two E1 templates and one J1 template, as well as an arbitrary waveform generator are provided. The data through the Waveform Shaper, the Line Driver and the Tx Transmitter is output on TTIPn and TRINGn.

Alarms (including LOS, AIS) and defects (including BPV, EXZ) are detected in both receive line side and transmit system side. AIS alarm, PRBS, ARB and IB patterns can be generated /detected in receive / transmit direction for testing purpose. Analog Loopback, Digital Loopback and Remote Loopback are all integrated for diagnostics.

JTAG per IEEE 1149.1 is also supported by the IDT82P20516.

**BLOCK DIAGRAM**



**Figure-1 Functional Block Diagram**

# 1 PIN ASSIGNMENT

	1	2	3	4	5	6	7	8	9	10	11	12	13	14	15	16	17	18	19	20	21	22		
A	NC	NC	NC	NC	RD15/ RDP15	TDN14	RCLK1 4	TDN13	RCLK1 3	TDN12	RCLK1 2	RCLK1 1	TDN11	RCLK1 0	TDN10	RCLK9	TDN9	RCLK8	NC	NC	NC	NC	A	
B	NC	NC	NC	NC	TCLK15/ TDP15	TD14/ TDP14	RDN14	TD13/ TDP13	RDN13	TD12/ TDP12	RDN12	RDN11	TD11/ TDP11	RDN10	TD10/ TDP10	RDN9	TD9/ TDP9	RD8/ RDP8	NC	NC	NC	NC	B	
C	TRING 12	NC	NC	NC	TD15/ TDP15	GNDD	GNDD	GNDD	GNDD	GNDD	GNDD	GNDD	GNDD	GNDD	GNDD	GNDD	GNDD	TDN8	NC	NC	NC	NC	C	
D	TTIP12	NC	NC	NC	TDN15	RDN15	TCLK14/ TDN14	VDDIO	TCLK13/ TDN13	GNDD	TCLK12/ TDN12	TCLK11/ TDN11	VDDIO	TCLK10/ TDN10	VDDIO	TCLK9/ TDN9	VDDIO	TD8/ TDP8	NC	NC	NC	NC	D	
E	TRING 13	GND A	GND A	GND A	NC	RCLK1 5	RD14/ RDP14	GNDD	RD13/ RDP13	VDDIO	RD12/ RDP12	RD11/ RDP11	GNDD	RD10/ RDP10	GNDD	RD9/ RDP9	RDN8	TCLK8/ TDN8	GND A	GND A	NC	TRING 11	E	
F	TTIP13	NC	GND A	GND A	VDDD	GNDD	GNDD	VDDD	NC	VDDD	GNDD	VDDIO	VDDD	VDDD	VDDD	VDDD	VDDD	VDDD	VDDD	GND A	GND A	NC	TTIP11	F
G	TRING 14	NC	RTIP12	RRING 12	VDDD	VDDD	GNDD	GNDD	GNDD	GNDD	VDDD	GNDD	GNDD	GNDD	GNDD	GNDD	GNDD	NC	RRING 11	RTIP11	NC	TRING 10	G	
H	TTIP14	NC	RTIP13	RRING 13	NC	VDDR1 2	GNDD	GNDD	GNDD	GNDD	GNDD	GNDD	GNDD	GNDD	GNDD	GNDD	GNDD	NC	RRING 10	RTIP10	NC	TTIP10	H	
J	TRING 15	NC	RTIP14	RRING 14	VDDT	VDDT	GNDT	GNDT	GNDT	GNDT	GNDT	GNDT	GNDT	GNDT	GNDT	VDDR1 1	VDDT	VDDT	RRING 9	RTIP9	NC	TRING 9	J	
K	TTIP15	NC	RTIP15	RRING 15	VDDT	VDDT	GNDT	VDDR1 3	VDDR1 4	GNDT	GNDT	GNDT	VDDR9	GNDT	VDDR1 0	GNDT	VDDT	VDDT	RRING 8	RTIP8	NC	TTIP9	K	
L	TRING 0	NC	RTIP0	RRING 0	VDDR0	VDDR1 5	VDDT	GNDT	VDDT	GNDT	GNDT	GNDT	VDDT	GNDT	GNDT	VDDT	VDDR8	NC	VCOM EN	REF	NC	TRING 8	L	
M	TTIP0	NC	RTIP1	RRING 1	VDDT	VDDT	VDDR2	GNDT	VDDR1	VDDT	GNDT	VDDA	GND A	GNDT	GNDT	VDDR7	VDDT	VDDA	VCOM1	VCOM0	GND A	TTIP8	M	
N	TRING 1	NC	RTIP2	RRING 2	VDDT	VDDT	VDDR3	GNDT	GNDT	GNDT	GNDT	VDDA	VDDT	NC	VDDT	VDDR6	VDDT	VDDT	RRING 7	RTIP7	VDDA	TRING 7	N	
P	TTIP1	NC	RTIP3	RRING 3	VDDT	VDDT	GNDT	VDDR4	GNDD	GNDD	NC	GNDD	VDDIO	NC	GNDD	GNDT	VDDR5	NC	RRING 6	RTIP6	NC	TTIP7	P	
R	TRING 2	NC	RTIP4	RRING 4	VDDT	VDDT	NC	NC	GNDD	VDDIO	VDDIO	VDDD	GNDD	VDDD	VDDD	VDDIO	GNDD	NC	RRING 5	RTIP5	NC	TRING 6	R	
T	TTIP2	NC	GND A	GND A	NC	NC	VDDIO	VDDD	VDDD	GNDD	GNDD	GNDD	GNDD	GNDD	GNDD	RDN6	VDDD	GNDD	VDDT	VDDT	GND A	NC	TTIP6	T
U	TRING 3	NC	GND A	GND A	NC	NC	NC	VDDD	VDDD	GNDD	GNDD	GNDD	GNDD	GNDD	GNDD	GNDD	GNDD	NC	GND A	GND A	NC	TRING 5	U	
V	TTIP3	NC	GND A	TD1/ TDP1	RDN1	TCLK2/ TDN2	TCLK3/ TDN3	TCLK4/ TDN4	RDN0	GPIO0	OE	TEHWE	CS	CLKB	MCK SEL3	TCLK6/ TDN6	TD7/ TDP7	RDN7	TD6/ TDP6	GND A	GND A	TTIP5	V	
W	TRING 4	NC	TCLK1/ TDN1	RCLK1	TDN2	TD2/ TDP2	RDN2	RDN3	RDN4	TCLK0/ TDN0	TMS	TCK	SDI	NC	NC	MCKSE L1	TCLK5/ TDN5	RCLK7	RDN5	IC	NC	NC	W	
Y	TTIP4	RD1/ RDP1	TDN1	NC	NC	NC	NC	NC	NC	NC	NC	NC	NC	NC	NC	NC	NC	NC	NC	NC	GNDD	NC	NC	Y
AA	NC	RD2/ RDP2	RCLK2	TD3/ TDP3	RD3/ RDP3	TD4/ TDP4	RCLK4	RD0/ RDP0	TDI	GPIO1	RST	SDO	LLOS0	CLKA	MCKSE L2	TD5/ TDP5	RCLK5	RD6/ RDP6	TDN7	TCLK7/ TDN7	RD7/ RDP7	NC	AA	
AB	TDN3	RCLK3	TDN4	RD4/ RDP4	TD0/ TDP0	TDN0	RCLK0	TRST	TDO	TEHW	RIM	SCLK	INT	LLOS	NC	CLKE1	MCKSE L0	MCLK	TDN5	RD5/ RDP5	TDN6	RCLK6	AB	

Figure-2 484-Pin Fine Pitch BGA (Top View)

## 2 PIN DESCRIPTION

Name	I/O	Pin No. <sup>1</sup>	Description
<b>Line Interface</b>			
RTIPn RRINGn (n=0~15)	Input	L3, M3, N3, P3, R3, R20, P20, N20, K20, J20, H20, G20, G3, H3, J3, K3  L4, M4, N4, P4, R4, R19, P19, N19, K19, J19, H19, G19, G4, H4, J4, K4	<p><b>RTIPn / RRINGn: Receive Bipolar Tip/Ring for Channel 0 ~ 15</b></p> <p>The receive line interface supports both Receive Differential mode and Receive Single Ended mode.</p> <p>In Receive Differential mode, the received signal is coupled into RTIPn and RRINGn via a 1:1 transformer or without a transformer (transformer-less).</p> <p>In Receive Single Ended mode, RRINGn should be left open. The received signal is input on RTIPn via a 2:1 (step down) transformer or without a transformer (transformer-less).</p> <p>These pins will become High-Z globally or channel specific in the following conditions:</p> <ul style="list-style-type: none"> <li>• Global High-Z: <ul style="list-style-type: none"> <li>- Connecting the RIM pin to low;</li> <li>- Loss of MCLK</li> <li>- During and after power-on reset, hardware reset or global software reset;</li> </ul> </li> <li>• Per-channel High-Z <ul style="list-style-type: none"> <li>- Receiver power down by writing '1' to the R_OFF bit (b5, RCF0,...)</li> </ul> </li> </ul>
TTIPn TRINGn (n=0~15)	Output	M1, P1, T1, V1, Y1, V22, T22, P22, M22, K22, H22, F22, D1, F1, H1, K1  L1, N1, R1, U1, W1, U22, R22, N22, L22, J22, G22, E22, C1, E1, G1, J1	<p><b>TTIPn / TRINGn: Transmit Bipolar Tip /Ring for Channel 0 ~ 15</b></p> <p>The transmit line interface supports both Transmit Differential mode and Transmit Single Ended mode.</p> <p>In Transmit Differential mode, TTIPn outputs a positive differential pulse while TRINGn outputs a negative differential pulse. The pulses are coupled to the line side via a 1:2 (step up) transformer or without a transformer (transformer-less).</p> <p>In Transmit Single Ended mode, TRINGn should be left open (it is shorted to ground internally). The signal presented at TTIPn is output to the line side via a 1:2 (step up) transformer.</p> <p>These pins will become High-Z globally or channel specific in the following conditions:</p> <ul style="list-style-type: none"> <li>• Global High-Z: <ul style="list-style-type: none"> <li>- Connecting the OE pin to low;</li> <li>- Loss of MCLK;</li> <li>- During and after power-on reset, hardware reset or global software reset;</li> </ul> </li> <li>• Per-channel High-Z <ul style="list-style-type: none"> <li>- Writing '0' to the OE bit (b6, TCF0,...) <sup>2</sup>;</li> <li>- Loss of TCLKn in Transmit Single Rail NRZ Format mode or Transmit Dual Rail NRZ Format mode, except that the channel is in Remote Loopback or transmit internal pattern with XCLK <sup>3</sup>;</li> <li>- Transmitter power down by writing '1' to the T_OFF bit (b5, TCF0,...);</li> <li>- Per-channel software reset;</li> <li>- The THZ_OC bit (b4, TCF0,...) is set to '1' and the transmit driver over-current is detected.</li> </ul> </li> </ul> <p>Refer to Section 3.3.8 Output High-Z on TTIP and TRING for details.</p>

**Note:**

1. The pin number of the pins with the footnote 'n' is listed in order of channel (CH0 ~ CH15).
2. The content in the brackets indicates the position and the register name of the preceding bit. After the register name, if the punctuation '...' is followed, this bit is in a per-channel register. The addresses and details are included in Chapter 5 Programming Information.
3. XCLK is derived from MCLK. It is 2.048 MHz in E1 mode.

Name	I / O	Pin No.	Description
<b>System Interface</b>			
RDn / RDPn (n=0~15)	Output	AA8, Y2, AA2, AA5, AB4, AB20, AA18, AA21, B18, E16, E14, E12, E11, E9, E7, A5	<p><b>RDn: Receive Data for Channel 0 ~ 15</b> When the receive system interface is configured to Single Rail NRZ Format mode, this multiplex pin is used as RDn. The decoded NRZ data is updated on the active edge of RCLKn. The active level on RDn is selected by the RD_INV bit (b3, RCF1,...). When the receiver is powered down, RDn will be in High-Z state or low, as selected by the RHZ bit (b6, RCF0,...).</p> <p><b>RDPn: Positive Receive Data for Channel 0 ~ 15</b> When the receive system interface is configured to Dual Rail NRZ Format mode, Dual Rail RZ Format mode or Dual Rail Sliced mode, this multiplex pin is used as RDPn. In Receive Dual Rail NRZ Format mode, the un-decoded NRZ data is output on RDPn and RDNn and updated on the active edge of RCLKn. In Receive Dual Rail RZ Format mode, the un-decoded RZ data is output on RDPn and RDNn and updated on the active edge of RCLKn. In Receive Dual Rail Sliced mode, the raw RZ sliced data is output on RDPn and RDNn. For Receive Differential line interface, an active level on RDPn indicates the receipt of a positive pulse on RTIPn and a negative pulse on RRINGn; while an active level on RDNn indicates the receipt of a negative pulse on RTIPn and a positive pulse on RRINGn. For Receive Single Ended line interface, an active level on RDPn indicates the receipt of a positive pulse on RTIPn; while an active level on RDNn indicates the receipt of a negative pulse on RTIPn. The active level on RDPn and RDNn is selected by the RD_INV bit (b3, RCF1,...). When the receiver is powered down, RDPn and RDNn will be in High-Z state or low, as selected by the RHZ bit (b6, RCF0,...).</p>
RDNn (n=0~15)	Output	V9, V5, W7, W8, W9, W19, T15, V18, E17, B16, B14, B12, B11, B9, B7, D6	<p><b>RDNn: Negative Receive Data for Channel 0 ~ 15</b> When the receive system interface is configured to Dual Rail NRZ Format mode, Dual Rail RZ Format mode or Dual Rail Sliced mode, this multiplex pin is used as RDNn. (Refer to the description of RDPn for details).</p>
RCLKn (n=0~15)	Output	AB7, W4, AA3, AB2, AA7, AA17, AB22, W18, A18, A16, A14, A12, A11, A9, A7, E6	<p><b>RCLKn: Receive Clock for Channel 0 ~ 15</b> When the receive system interface is configured to Single Rail NRZ Format mode, Dual Rail NRZ Format mode or Dual Rail RZ Format mode, this multiplex pin is used as RCLKn. RCLKn outputs a 2.048 MHz (in E1 mode) clock which is recovered from the received signal. The data output on RDPn/RDNn (in Receive Dual Rail NRZ Format mode, Receive Dual Rail RZ Format mode and Receive Dual Rail Sliced) is updated on the active edge of RCLKn. The active edge is selected by the RCK_ES bit (b4, RCF1,...). In LLOS condition, RCLKn output high or XCLK, as selected by the RCKH bit (b7, RCF0,...) (refer to Section 3.5.3.1 Line LOS (LLOS) for details). When the receiver is powered down, RCLKn will be in High-Z state or low, as selected by the RHZ bit (b6, RCF0,...).</p>
LLOS	Output	AB14	<p><b>LLOS: Receive Line Loss Of Signal</b> LLOS synchronizes with the output of CLKE1 and can indicate the LLOS (Line LOS) status of all 16 channels in a serial format. When the clock output on CLKE1 is enabled, LLOS indicates the LLOS status of the 16 channels in a serial format and repeats every seventeen cycles. The start filler is positioned by LLOS0. Refer to the description of LLOS0 below for details. LLOS is updated on the rising edge of CLKE1 and is always active high. When the clock output of CLKE1 is disabled, LLOS will be held in High-Z state. (Refer to Section 3.5.3.1 Line LOS (LLOS) for details.)</p>

Name	I / O	Pin No.	Description																				
LLOS0	Output	AA13	<p><b>LLOS0: Receive Line Loss Of Signal for Start Position</b>                      LLOS0 can indicate the start position on the LLOS pin.                      When the clock output on CLKE1 is enabled, LLOS0 pulses high for one CLKE1 clock cycle to indicate the start position on the LLOS pin. When CLKE1 outputs 8 KHz clock, LLOS0 pulses high for one 8 KHz clock cycle (125 μs) every seventeen 8 KHz clock cycles; when CLKE1 outputs 2.048 MHz clock, LLOS0 pulses high for one 2.048 MHz clock cycle (488 ns) every seventeen 2.048 MHz clock cycles. LLOS0 is updated on the rising edge of CLKE1.                      When the clock output on CLKE1 is disabled, LLOS0 will be held in High-Z state.                      (Refer to Section 3.5.3.1 Line LOS (LLOS) for details.)</p>																				
TDn / TDPn (n=0~15)	Input	AB5, V4, W6, AA4, AA6, AA16, V19, V17, D18, B17, B15, B13, B10, B8, B16, C5	<p><b>TDn: Transmit Data for Channel 0 ~ 15</b>                      When the transmit system interface is configured to Single Rail NRZ Format mode, this multiplex pin is used as TDn.                      TDn accepts Single Rail NRZ data. The data is sampled into the device on the active edge of TCLKn.                      The active level on TDn is selected by the TD_INV bit (b3, TCF1,...).</p> <p><b>TDPn: Positive Transmit Data for Channel 0 ~ 15</b>                      When the transmit system interface is configured to Dual Rail NRZ Format mode or Dual Rail RZ Format mode, this multiplex pin is used as TDPn.                      In Transmit Dual Rail NRZ Format mode, the pre-encoded NRZ data is input on TDPn and TDNn and sampled on the active edge of TCLKn.                      In Transmit Dual Rail RZ Format mode, the pre-encoded RZ data is input on TDPn and TDNn. The line code is as follows (when the TD_INV bit (b3, TCF1,...) is '0'):</p> <table border="1" style="width: 100%; border-collapse: collapse;"> <thead> <tr> <th>TDPn</th> <th>TDNn</th> <th>Output Pulse on TTIPn</th> <th>Output Pulse on TRINGn *</th> </tr> </thead> <tbody> <tr> <td>0</td> <td>0</td> <td>Space</td> <td>Space</td> </tr> <tr> <td>0</td> <td>1</td> <td>Negative Pulse</td> <td>Positive Pulse</td> </tr> <tr> <td>1</td> <td>0</td> <td>Positive Pulse</td> <td>Negative Pulse</td> </tr> <tr> <td>1</td> <td>1</td> <td>Space</td> <td>Space</td> </tr> </tbody> </table> <p><b>Note:</b>                      * For Transmit Single Ended line interface, TRINGn should be open.</p> <p>The active level on TDPn and TDNn is selected by the TD_INV bit (b3, TCF1,...).</p>	TDPn	TDNn	Output Pulse on TTIPn	Output Pulse on TRINGn *	0	0	Space	Space	0	1	Negative Pulse	Positive Pulse	1	0	Positive Pulse	Negative Pulse	1	1	Space	Space
TDPn	TDNn	Output Pulse on TTIPn	Output Pulse on TRINGn *																				
0	0	Space	Space																				
0	1	Negative Pulse	Positive Pulse																				
1	0	Positive Pulse	Negative Pulse																				
1	1	Space	Space																				
TDNn (n=0~15)	Input / Output	AB6, Y3, W5, AB1, AB3, AB19, AB21, AA19, C18, A17, A15, A13, A10, A8, A6, D5	<p><b>TDNn: Negative Transmit Data for Channel 0 ~ 15</b>                      When the transmit system interface is configured to Dual Rail NRZ Format mode, this multiplex pin is used as TDNn.                      (Refer to the description of TDPn for details).</p>																				
TCLKn / TDNn (n=0~15)	Input	W10, W3, V6, V7, V8, W17, V16, AA20, E18, D16, D14, D12, D11, D9, D7, B5	<p><b>TCLKn: Transmit Clock for Channel 0 ~ 15</b>                      When the transmit system interface is configured to Single Rail NRZ Format mode or Dual Rail NRZ Format mode, this multiplex pin is used as TCLKn.                      TCLKn inputs a 2.048 MHz (in E1 mode) clock.                      The data input on TDn (in Transmit Single Rail NRZ Format mode) or TDPn/TDNn (in Transmit Dual Rail NRZ Format mode) is sampled on the active edge of TCLKn.</p> <p><b>TDNn: Negative Transmit Data for Channel 0 ~ 15</b>                      When the transmit system interface is configured to Dual Rail RZ Format mode, this multiplex pin is used as TDNn.                      (Refer to the description of TDPn for details).</p>																				

Name	I/O	Pin No.	Description																																		
<b>Clock</b>																																					
MCLK	Input	AB18	<p><b>MCLK: Master Clock Input</b>                      MCLK provides a stable reference timing for the IDT82P20516. MCLK should be a clock with +/-50 ppm (in E1 mode) accuracy. The clock frequency of MCLK is informed to the device by MCKSEL[3:0].                      If MCLK misses (duty cycle is less than 30% for 10 μs) and then recovers, the device will be reset automatically.</p>																																		
MCKSEL[0] MCKSEL[1] MCKSEL[2] MCKSEL[3]	Input	AB17 W16 AA15 V15	<p><b>MCKSEL[3:0]: Master Clock Selection</b>                      These four pins inform the device of the clock frequency input on MCLK:</p> <table border="1" style="margin-left: 40px;"> <thead> <tr> <th>MCKSEL[3:0]*</th> <th>Frequency (MHz)</th> </tr> </thead> <tbody> <tr><td>0000</td><td>1.544</td></tr> <tr><td>0001</td><td>1.544 X 2</td></tr> <tr><td>0010</td><td>1.544 X 3</td></tr> <tr><td>0011</td><td>1.544 X 4</td></tr> <tr><td>0100</td><td>1.544 X 5</td></tr> <tr><td>0101</td><td>1.544 X 6</td></tr> <tr><td>0110</td><td>1.544 X 7</td></tr> <tr><td>0111</td><td>1.544 X 8</td></tr> <tr><td>1000</td><td>2.048</td></tr> <tr><td>1001</td><td>2.048 X 2</td></tr> <tr><td>1010</td><td>2.048 X 3</td></tr> <tr><td>1011</td><td>2.048 X 4</td></tr> <tr><td>1100</td><td>2.048 X 5</td></tr> <tr><td>1101</td><td>2.048 X 6</td></tr> <tr><td>1110</td><td>2.048 X 7</td></tr> <tr><td>1111</td><td>2.048 X 8</td></tr> </tbody> </table> <p><b>Note:</b>                      0: GNDD                      1: VDDIO</p>	MCKSEL[3:0]*	Frequency (MHz)	0000	1.544	0001	1.544 X 2	0010	1.544 X 3	0011	1.544 X 4	0100	1.544 X 5	0101	1.544 X 6	0110	1.544 X 7	0111	1.544 X 8	1000	2.048	1001	2.048 X 2	1010	2.048 X 3	1011	2.048 X 4	1100	2.048 X 5	1101	2.048 X 6	1110	2.048 X 7	1111	2.048 X 8
MCKSEL[3:0]*	Frequency (MHz)																																				
0000	1.544																																				
0001	1.544 X 2																																				
0010	1.544 X 3																																				
0011	1.544 X 4																																				
0100	1.544 X 5																																				
0101	1.544 X 6																																				
0110	1.544 X 7																																				
0111	1.544 X 8																																				
1000	2.048																																				
1001	2.048 X 2																																				
1010	2.048 X 3																																				
1011	2.048 X 4																																				
1100	2.048 X 5																																				
1101	2.048 X 6																																				
1110	2.048 X 7																																				
1111	2.048 X 8																																				
CLKE1	Output	AB16	<p><b>CLKE1: 8 KHz / E1 Clock Output</b>                      The output on CLKE1 can be enabled or disabled, as determined by the CLKE1_EN bit (b3, CLKG).                      When the output is enabled, CLKE1 outputs an 8 KHz or 2.048 MHz clock, as selected by the CLKE1 bit (b2, CLKG). The output is locked to MCLK.                      When the output is disabled, CLKE1 is in High-Z state.</p>																																		
CLKA	Input	AA14	<p><b>CLKA: External E1 Clock Input A</b>                      External E1 (2.048 MHz) clock is input on this pin.                      When not used, this pin should be connected to GNDD.</p>																																		
CLKB	Input	V14	<p><b>CLKB: External E1 Clock Input B</b>                      External E1 (2.048 MHz) clock is input on this pin.                      When not used, this pin should be connected to GNDD.</p>																																		



Name	I / O	Pin No.	Description
<b>Common Control</b>			
VCOM[0] VCOM[1]	Output	M20 M19	<b>VCOM: Voltage Common Mode [1:0]</b> These pins are used only when the receive line interface is in Receive Differential mode and connected without a transformer (transformer-less). To enable these pins, the VCOMEN pin must be connected high. Refer to Figure-6 for the connection. When these pins are not used, they should be left open.
VCOMEN	Input (Pull-Down)	L19	<b>VCOMEN: Voltage Common Mode Enable</b> This pin should be connected high only when the receive line interface is in Receive Differential mode and connected without a transformer (transformer-less). When not used, this pin should be left open.
REF	-	L20	<b>REF: Reference Resistor</b> An external resistor (10 K $\Omega$ , $\pm 1\%$ ) is used to connect this pin to ground to provide a standard reference current for internal circuit. This resistor is required to ensure correct device operation.
RIM	Input (Pull-Down)	AB11	<b>RIM: Receive Impedance Matching</b> In Receive Differential mode, when RIM is low, all 16 receivers become High-Z and only external impedance matching is supported. In this case, the per-channel impedance matching configuration bits - the R_TERM[2:0] bits (b2~0, RCF0,...) and the R120IN bit (b4, RCF0,...) - are ignored. In Receive Differential mode, when RIM is high, impedance matching is configured on a per-channel basis by the R_TERM[2:0] bits (b2~0, RCF0,...) and the R120IN bit (b4, RCF0,...). This pin can be used to control the receive impedance state for Hitless Protection applications. Refer to Section 4.4 Hitless Protection Switching (HPS) Summary for details. In Receive Single Ended mode, this pin should be left open.
OE	Input	V11	<b>OE: Output Enable</b> OE enables or disables all Line Drivers globally. A high level on this pin enables all Line Drivers while a low level on this pin places all Line Drivers in High-Z state and independent from related register settings. Note that the functionality of the internal circuit is not affected by OE. If this pin is not used, it should be tied to VDDIO. This pin can be used to control the transmit impedance state for Hitless protection applications. Refer to Section 4.4 Hitless Protection Switching (HPS) Summary for details.
TEHWE	Input (Pull-Up)	V12	<b>TEHWE: Hardware E1 Mode Selection Enable</b> When this pin is open, the E1 operation mode is selected by TEHW globally. When this pin is low, the E1 operation mode is selected by the E1 bit (b0, CHCF,...) on a per-channel basis.
TEHW	Input (Pull-Up)	AB10	<b>TEHW: Hardware E1 Mode Selection</b> When TEHWE is open, this pin selects the E1 operation mode globally: Low - E1 mode; When TEHWE is low, the input on this pin is ignored.
GPIO[0] GPIO[1]	Output / Input	V10 AA10	<b>GPIO: General Purpose I/O [1:0]</b> These two pins can be defined as input pins or output pins by the DIR[1:0] bits (b1~0, GPIO) respectively. When the pins are input, their polarities are indicated by the LEVEL[1:0] bits (b3~2, GPIO) respectively. When the pins are output, their polarities are controlled by the LEVEL[1:0] bits (b3~2, GPIO) respectively.
$\overline{\text{RST}}$	Input	AA11	<b><math>\overline{\text{RST}}</math>: Reset (Active Low)</b> A low pulse on this pin resets the device. This hardware reset process completes in 2 $\mu\text{s}$ maximum. Refer to Section 4.1 Reset for an overview on reset options.



Name	I / O	Pin No.	Description
<b>MCU Interface</b>			
$\overline{\text{INT}}$	Output	AB13	<b><math>\overline{\text{INT}}</math>: Interrupt Request</b> This pin indicates interrupt requests for all unmasked interrupt sources. The output characteristics (open drain or push-pull internally) and the active level are determined by the INT_PIN[1:0] bits (b3~2, GCF).
$\overline{\text{CS}}$	Input	V13	<b><math>\overline{\text{CS}}</math>: Chip Select (Active Low)</b> This pin must be asserted low to enable the microprocessor interface. A transition from high to low must occur on this pin for each Read/Write operation and $\overline{\text{CS}}$ should remain low until the operation is over.
SCLK	Input	AB12	<b>SCLK: Shift Clock</b> In Serial microprocessor interface, this multiplex pin is used as SCLK. SCLK inputs the shift clock for the Serial microprocessor interface. Data on SDI is sampled by the device on the rising edge of SCLK. Data on SDO is updated on the falling edge of SCLK.
SDI	Input	W13	<b>SDI: Serial Data Input</b> In Serial microprocessor interface, this multiplex pin is used as SDI. Address and data on this pin are serially clocked into the device on the rising edge of SCLK.
SDO	Output	AA12	<b>SDO: Serial Data Output</b> In Serial microprocessor interface, this multiplex pin is used as SDO. Data on this pin is serially clocked out of the device on the falling edge of SCLK.
<b>JTAG (per IEEE 1149.1)</b>			
$\overline{\text{TRST}}$	Input Pull-Down	AB8	<b><math>\overline{\text{TRST}}</math>: JTAG Test Reset (Active Low)</b> A low signal on this pin resets the JTAG test port. To ensure deterministic operation of the test logic, TMS should be held high when the signal on $\overline{\text{TRST}}$ changes from low to high. This pin may be left unconnected when JTAG is not used. This pin has an internal pull-down resistor.
TMS	Input Pull-up	W11	<b>TMS: JTAG Test Mode Select</b> The signal on this pin controls the JTAG test performance and is sampled on the rising edge of TCK. To ensure deterministic operation of the test logic, TMS should be held high when the signal on $\overline{\text{TRST}}$ changes from low to high. This pin may be left unconnected when JTAG is not used. This pin has an internal pull-up resistor.
TCK	Input	W12	<b>TCK: JTAG Test Clock</b> The clock for the JTAG test is input on this pin. TDI and TMS are sampled on the rising edge of TCK and TDO is updated on the falling edge of TCK. When TCK is idle at low state, all stored-state devices contained in the test logic shall retain their state indefinitely. This pin should be connected to GNDD when JTAG is not used.
TDI	Input Pull-up	AA9	<b>TDI: JTAG Test Data Input</b> The test data is input on this pin. It is clocked into the device on the rising edge of TCK. This pin has an internal pull-up resistor. This pin may be left unconnected when JTAG is not used.
TDO	Output	AB9	<b>TDO: JTAG Test Data Output</b> The test data is output on this pin. It is clocked out of the device on the falling edge of TCK. TDO is a High-Z output signal except during the process of data scanning.
<b>Power &amp; Ground</b>			
VDDIO		D8, D13, D15, D17, E10, F12, P13, R10, R11, R16, T7	<b>VDDIO: 3.3 V I/O Power Supply</b>
VDDA		N21, M12, N12, M18	<b>VDDA: 3.3 V Analog Core Power Supply</b>

Name	I / O	Pin No.	Description
VDDD		F5, F8, F10, F13, F14, F15, F16, F17, F18, G5, G6, G11, R12, R14, R15, T8, T9, T16, U8, U9	<b>VDDD: 1.8 V Digital Core Power Supply</b>
VDDRn (N=0~15)		H6, J16, K8, K9, K13, K15, L5, L6, L17, M7, M9, M16, N7, N16, P8, P17	<b>VDDRn: 3.3 V Power Supply for Receiver</b>
VDDT		J5, J6, J17, J18, K5, K6, K17, K18, L7, L9, L13, L16, M5, M6, M10, M17, N5, N6, N13, N15, N17, N18, P5, P6, R5, R6, T18, T19	<b>VDDT: 3.3 V Power Supply for Transmitter Driver</b>
GNDA		E2, E3, E4, E19, E20, F3, F4, F19, F20, M13, M21, T3, T4, T20, U3, U4, U19, U20, V3, V20, V21	<b>GNDA: GND for Analog Core / Receiver</b>
GNDD		C6, C7, C8, C9, C10, C11, C12, C13, C14, C15, C16, C17, D10, E8, E13, E15, F6, F7, F11, G7, G8, G9, G10, G12, G13, G14, G15, G16, G17, H7, H8, H9, H10, H11, H12, H13, H14, H15, H16, H17, P9, P10, P12, P15, R9, R13, R17, T10, T11, T12, T13, T14, T17, U10, U11, U12, U13, U14, U15, U16, U17, Y20	<b>GNDD: Digital GND</b>
GNDT		J7, J8, J9, J10, J11, J12, J13, J14, J15, K7, K10, K11, K12, K14, K16, L8, L10, L11, L12, L14, L15, M8, M11, M14, M15, N8, N9, N10, N11, P7, P16	<b>GNDT: Analog GND for Transmitter Driver</b>
<b>TEST</b>			
NC	-	A1, A2, A3, A4, A19, A20, A21, A22, B1, B2, B3, B4, B19, B20, B21, B22, C2, C3, C4, C19, C20, C21, C22, D2, D3, D4, D19, D20, D21, D22, E5, E21, F2, F9, F21, G2, G18, G21, H2, H5, H18, H21, J2, J21, K2, K21, L2, L18, L21, M2, N2, N14, P2, P11, P14, P18, P21, R2, R7, R8, R18, R21, T2, T5, T6, T21, U2, U5, U6, U7, U18, U21, V2, W2, W21, W22, Y4, Y5, Y6, Y7, Y8, Y9, Y10, Y11, Y12, Y13, Y14, Y15, Y16, Y17, Y18, Y19, Y21, Y22, AA1, AA22, AB15, W14, W15	<b>NC: No Connected</b> These pins should be left open.
<b>Others</b>			
IC		W20	<b>IC: Internal Connected</b> This pin is for IDT use only and should be connected to GNDD.

### 3 FUNCTIONAL DESCRIPTION

#### 3.1 E1 MODE SELECTION

The IDT82P20516 can be configured to E1 mode globally or on a per-channel basis. The configuration is determined by the TEHWE pin, the TEHW pin and the E1 bit (b0, CHCF,...). Refer to Table-1 for details of the operation mode selection.

Table-1 Operation Mode Selection

	Global Programming		Per-Channel Programming	
TEHWE Pin	Open		Low	
TEHW Pin	Open	Low	(The configuration of this pin is ignored)	
E1 Bit	(The configuration of this bit is ignored).		0	1
Operation Mode		E1		E1

#### 3.2 RECEIVE PATH

##### 3.2.1 R<sub>x</sub> TERMINATION

The receive line interface supports Receive Differential mode. In Receive Differential mode, both RTIP<sub>n</sub> and RRING<sub>n</sub> are used to receive signal from the line side.

In Receive Differential mode, the line interface can be connected with E1 120 Ω twisted pair cable or E1 75 Ω coaxial cable.

The receive impedance matching is realized by using internal impedance matching or external impedance matching for each channel in different applications.

##### 3.2.1.1 Receive Differential Mode

In Receive Differential mode, three kinds of impedance matching are supported: Fully Internal Impedance Matching, Partially Internal Impedance Matching and External Impedance Matching. Figure-3 shows an overview of how these Impedance Matching modes are switched.

Fully Internal Impedance Matching circuit uses an internal programmable resistor (IM) only and does not use an external resistor. This configuration saves external components and supports 1:1 Hitless Protection Switching (HPS) applications without relays. Refer to Section 4.4 Hitless Protection Switching (HPS) Summary.

Partially Internal Impedance Matching circuit consists of an internal programmable resistor (IM) and a value-fixed 120 Ω external resistor (R<sub>r</sub>). Compared with Fully Internal Impedance Matching, this configuration provides considerable savings in power dissipation of the device. For example, In E1 120 Ω PRBS mode, the power savings would be 0.44 W. For power savings in other modes, please refer to Chapter 8 Physical And Electrical Specifications.

External Impedance Matching circuit uses an external resistor (R<sub>r</sub>) only.

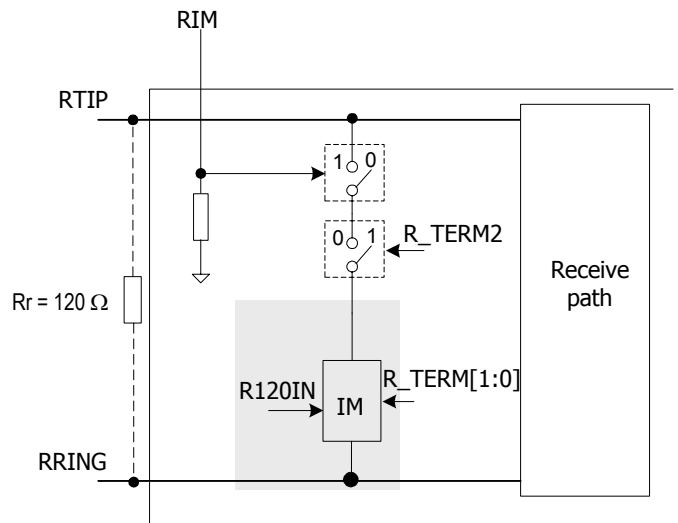


Figure-3 Switch between Impedance Matching Modes

To support some particular applications, such as hot-swap or Hitless Protection Switch (HPS) hot-switchover, RTIP<sub>n</sub>/RRING<sub>n</sub> must be forced to enter high impedance state (i.e., External Impedance Matching). For hot-swap, RTIP<sub>n</sub>/RRING<sub>n</sub> must be always held in high impedance state during /after power up; for HPS hot-switchover, RTIP<sub>n</sub>/RRING<sub>n</sub> must enter high impedance state immediately after switchover. Though each channel can be individually configured to External Impedance Matching through register access, it is too slow for hitless switch. Therefore, a hardware pin - RIM - is provided to globally control the high impedance for all 16 receivers.

When RIM is low, only External Impedance Matching is supported for all 16 receivers and the per-channel impedance matching configuration bits - the R\_TERM[2:0] bits (b2~0, RCF0,...) and the R120IN bit (b4, RCF0,...) - are ignored.

When RIM is high, impedance matching is configured on a per-channel basis. Three kinds of impedance matching are all supported and selected by the R\_TERM[2:0] bits (b2~0, RCF0,...) and the R120IN bit (b4, RCF0,...). The R\_TERM[2] bit (b2, RCF0,...) should be set to match internal or external impedance. If the R\_TERM[2] bit (b2, RCF0,...) is '0', internal impedance matching is enabled. The R120IN bit (b4, RCF0,...) should be set to select Partially Internal Impedance Matching or Fully Internal Impedance Matching. The internal programmable resistor (IM) is determined by the R\_TERM[1:0] bits (b1~0, RCF0,...). If the R\_TERM[2] bit (b2, RCF0,...) is '1', external impedance matching is enabled. The configuration of the R120IN bit (b4, RCF0,...) and the R\_TERM[1:0] bits (b1~0, RCF0,...) is ignored.

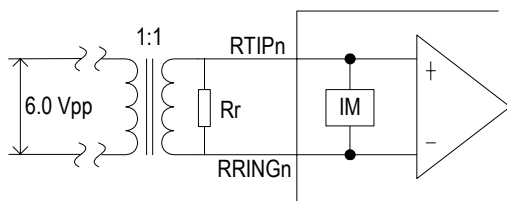
A twisted pair cable can be connected with a 1:1 transformer or without a transformer (transformer-less), while a coaxial cable must be connected with a 1:1 transformer. Table 2 lists the recommended impedance matching value in different applications. Figure-4 to Figure-6 show the connection for one channel.

The transformer-less connection will offer a termination option with reduced cost and board space. However, the waveform amplitude is not standard compliant, and surge protection and common mode depression should be enhanced depending on equipment environment.

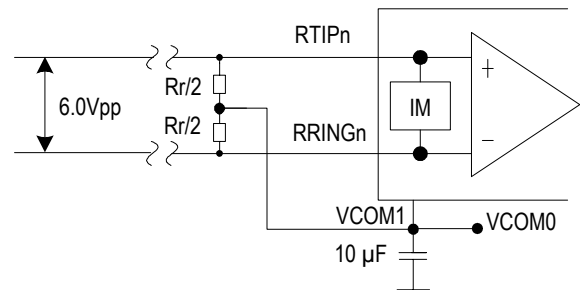
**Table-2 Impedance Matching Value in Receive Differential Mode**

Cable Condition	Partially Internal Impedance Matching (R120IN = 0) <sup>1</sup>		Fully Internal Impedance Matching (R120IN = 1) <sup>1,2</sup>		External Impedance Matching	
	R_TERM[2:0]	Rr	R_TERM[2:0]	Rr	R_TERM[2:0] <sup>3</sup>	Rr
E1 120 Ω twisted pair (with transformer)	010	120 Ω	010	(open)	1XX	120 Ω
E1 75 Ω coaxial (with transformer)	011		011			75 Ω
E1 120 Ω twisted pair (transformer-less)	010		(not supported)	120 Ω		

- Note:**
1. Partially Internal Impedance Matching and Fully Internal Impedance Matching are not supported when RIM is low.
  2. Fully Internal Impedance Matching is not supported in transformer-less applications.
  3. When RIM is low, the setting of the R\_TERM[2:0] bits is ignored.

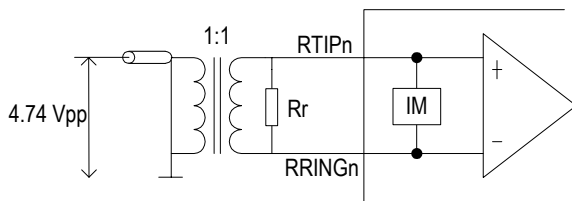


**Figure-4 Receive Differential Line Interface with Twisted Pair Cable (with transformer)**



- Note:**
1. Two Rr/2 resistors should be connected to VCOM[1:0] that are coupled to ground via a 10 μF capacitor, which provide 60 Ω common mode input resistance.
  2. In this mode, lightning protection should be enhanced.
  3. The maximum input dynamic range of RTIP/TRING pin is -0.3 V ~ 3.6 V (in line monitor mode it is -0.3 V ~ 2 V)

**Figure-6 Receive Differential Line Interface with Twisted Pair Cable (transformer-less, non standard compliant)**



**Figure-5 Receive Differential Line Interface with Coaxial Cable (with transformer)**

**3.2.2 EQUALIZER**

The equalizer compensates high frequency attenuation to enhance receive sensitivity.

**3.2.2.1 Line Monitor**

In both E1 short haul applications, the Protected Non-Intrusive Monitoring can be performed between two devices. The monitored channel of one device is in normal operation, and the monitoring channel of the other device taps the monitored one through a high impedance bridging circuit (refer to Figure-7 and Figure-8).

After the high resistance bridging circuit, the signal arriving at RTIPn/RRINGn of the monitoring channel is dramatically attenuated. To compensate this bridge resistive attenuation, Monitor Gain can be used to boost the signal by 20 dB, 26 dB or 32 dB, as selected by the MG[1:0] bits (b1~0, RCF2,...). For normal operation, the Monitor Gain should be set to 0 dB, i.e., the Monitor Gain of the monitored channel should be 0 dB.

The monitoring channel can be configured to any of the External, Partially Internal or Fully Internal Impedance Matching mode. Here the external r or internal IM is used for voltage division, not for impedance matching. That is, the r (IM) and the two R make up of a resistance bridge. The resistive attenuation of this bridge is  $20\lg(r/(2R+r))$  dB.

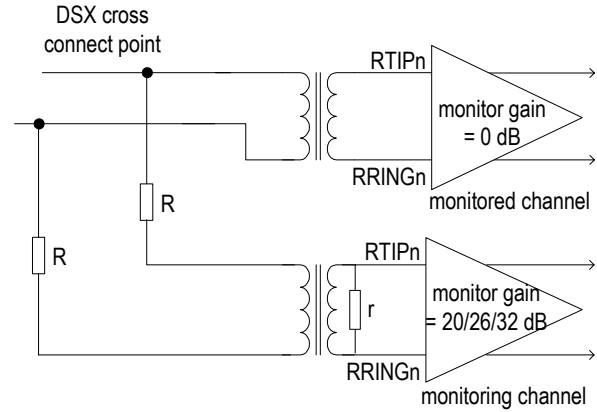
Note that line monitor is only available in differential line interface.

**3.2.2.2 Receive Sensitivity**

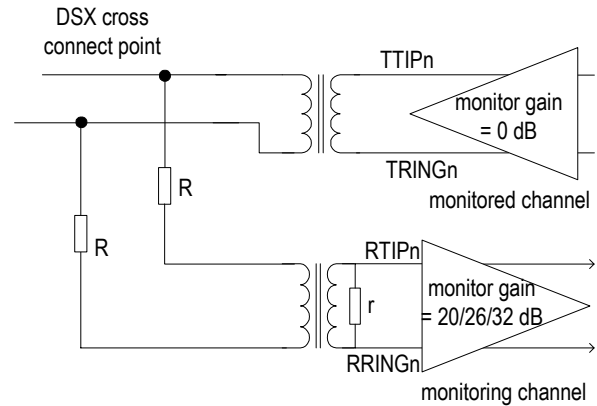
The receive sensitivity is the minimum range of receive signal level for which the receiver recovers data error-free with -18 dB interference signal added.

For Receive Differential line interface, the receive sensitivity is -15 dB.

For Receive Single Ended line interface, the receive sensitivity is -12 dB.



**Figure-7 Receive Path Monitoring**



**Figure-8 Transmit Path Monitoring**

**3.2.3 SLICER**

The Slicer is used to generate a standard amplitude mark or a space according to the amplitude of the input signals. The input signal is sliced at 50% of the peak value.

**3.2.4 R<sub>x</sub> CLOCK & DATA RECOVERY**

The Rx Clock & Data Recovery is used to recover the clock signal from the received data. It is accomplished by an integrated Digital Phase Locked Loop (DPLL). The recovered clock tracks the jitter in the data output from the Slicer and keeps the phase relationship between data and clock during the absence of the incoming pulse.

**3.2.5 DECODER**

The Decoder is used only when the receive system interface is in Single Rail NRZ Format mode. When the receive system interface is in other modes, the Decoder is bypassed automatically. (Refer to Section 3.2.6 Receive System Interface for the description of the receive system interface).

In E1 mode, the received signal is decoded by AMI or HDB3 line code rule. The line code rule is selected by the R\_CODE bit (b2, RCF1,...).

**3.2.6 RECEIVE SYSTEM INTERFACE**

The received data can be output to the system side in four modes: Single Rail NRZ Format mode, Dual Rail NRZ Format mode, Dual Rail RZ Format mode and Dual Rail Sliced mode, as selected by the R\_MD[1:0] bits (b1~0, RCF1).

If data is output on RDn in NRZ format and the recovered clock is output on RCLKn, the receive system interface is in Single Rail NRZ Format mode. In this mode, the data is decoded and updated on the active edge of RCLKn. RCLKn outputs a 2.048 MHz (in E1 mode) clock.

If data is output on RDPn and RDNn in NRZ format and the recovered clock is output on RCLKn, the receive system interface is in Dual Rail NRZ Format mode. In this mode, the data is un-decoded and updated on the active edge of RCLKn. RCLKn outputs a 2.048 MHz (in E1 mode) clock.

If data is output on RDPn and RDNn in RZ format and the recovered clock is output on RCLKn, the receive system interface is in Dual Rail RZ Format mode. In this mode, the data is un-decoded and updated on the active edge of RCLKn. RCLKn outputs a 2.048 MHz (in E1 mode) clock.

If data is output on RDPn and RDNn in RZ format directly after passing through the Slicer, the receive system interface is in Dual Rail Sliced mode. In this mode, the data is raw sliced and un-decoded.

Table-3 summarizes the multiplex pin used in different receive system interface.

**Table-3 Multiplex Pin Used in Receive System Interface**

Receive System Interface	Multiplex Pin Used On Receive System Interface		
	RDn / RDPn	RDNn	RCLKn
Single Rail NRZ Format	RDn <sup>1</sup>		RCLKn <sup>2</sup>
Dual Rail NRZ Format	RDPn <sup>1</sup>	RDNn <sup>1</sup>	RCLKn <sup>2</sup>
Dual Rail RZ Format	RDPn <sup>1</sup>	RDNn <sup>1</sup>	RCLKn <sup>2</sup>
Dual Rail Sliced	RDPn <sup>1</sup>	RDNn <sup>1</sup>	
<b>Note:</b>			
1. The active level on RDn, RDPn and RDNn is selected by the RD_INV bit (b3, RCF1,...).			
2. The active edge of RCLKn is selected by the RCK_ES bit (b4, RCF1,...).			

**3.2.7 RECEIVER POWER DOWN**

Set the R\_OFF bit (b5, RCF0,...) to '1' will power down the corresponding receiver.

In this way, the corresponding receive circuit is turned off and the RTIPn/RRINGn pins are forced to High-Z state. The pins on receive system interface (including RDn/RDPn, RDNn, RCLKn) will be in High-Z state if the RHZ bit (b6, RCF0,...) is '1' or in low level if the RHZ bit (b6, RCF0,...) is '0'.

After clearing the R\_OFF bit (b5, RCF0,...), it will take 1 ms for the receiver to achieve steady state, i.e., to return to the previous configuration and performance.

**3.3 TRANSMIT PATH**

**3.3.1 TRANSMIT SYSTEM INTERFACE**

The data from the system side is input to the device in three modes: Single Rail NRZ Format mode, Dual Rail NRZ Format mode and Dual Rail RZ Format mode, as selected by the T\_MD[1:0] bits (b1~0, TCF1,...).

If data is input on TDn in NRZ format and a 2.048 MHz (in E1 mode) clock is input on TCLKn, the transmit system interface is in Single Rail NRZ Format mode. In this mode, the data is encoded and sampled on the active edge of TCLKn.

If data is input on TDPn and TDNn in NRZ format and a 2.048 MHz (in E1 mode) clock is input on TCLKn, the transmit system interface is in Dual Rail NRZ Format mode. In this mode, the data is pre-encoded and sampled on the active edge of TCLKn.

If data is input on TDPn and TDNn in RZ format and no transmit clock is input, the transmit system interface is in Dual Rail RZ Format mode. In this mode, the data is pre-encoded.

Table-4 summarizes the multiplex pin used in different transmit system interface.

**Table-4 Multiplex Pin Used in Transmit System Interface**

Transmit System Interface	Multiplex Pin Used On Transmit System Interface		
	TDn / TDPn	TDNn	TCLKn / TDNn
Single Rail NRZ Format	TDn <sup>1</sup>		TCLKn <sup>2</sup>
Dual Rail NRZ Format	TDPn <sup>1</sup>	TDNn <sup>1</sup>	TCLKn <sup>2</sup>
Dual Rail RZ Format	TDPn <sup>1</sup>		TDNn <sup>1</sup>

**Note:**  
 1. The active level on TDn, TDPn and TDNn is selected by the TD\_INV bit (b3, TCF1,...).  
 2. The active edge of TCLKn is selected by the TCK\_ES bit (b4, TCF1,...). If TCLKn is missing, i.e., no transition for more than 64 E1 clock cycles, the TCKLOS\_S bit (b3, STAT0,...) will be set. A transition from '0' to '1' on the TCKLOS\_S bit (b3, STAT0,...) or any transition (from '0' to '1' or from '1' to '0') on the TCKLOS\_S bit (b3, STAT0,...) will set the TCKLOS\_IS bit (b3, INTS0,...) to '1', as selected by the TCKLOS\_IES bit (b3, INTES,...). When the TCKLOS\_IS bit (b3, INTS0,...) is '1', an interrupt will be reported by INT if not masked by the TCKLOS\_IM bit (b3, INTM0,...).

**3.3.2 Tx CLOCK RECOVERY**

The Tx Clock Recovery is used only when the transmit system interface is in Dual Rail RZ Format mode. When the transmit system interface is in other modes, the Tx Clock Recovery is bypassed automatically.

The Tx Clock Recovery is used to recover the clock signal from the data input on TDPn and TDNn.

**3.3.3 ENCODER**

The Encoder is used only when the transmit system interface is in Single Rail NRZ Format mode. When the transmit system interface is in other modes, the Encoder is bypassed automatically.

In E1 mode, the data to be transmitted is encoded by AMI or HDB3 line code rule. The line code rule is selected by the T\_CODE bit (b2, TCF1,...).

**3.3.4 WAVEFORM SHAPER**

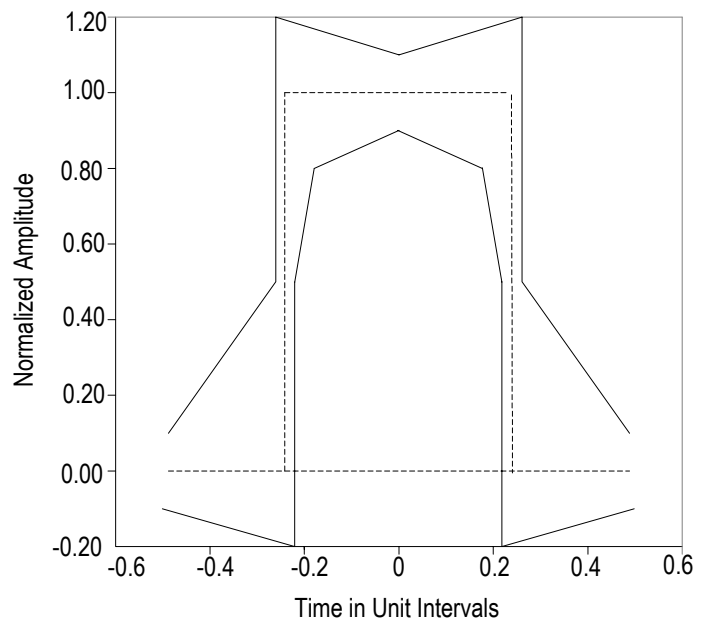
The IDT82P20516 provides two ways to manipulate the pulse shape before data is transmitted:

- Preset Waveform Template;
- User-Programmable Arbitrary Waveform.

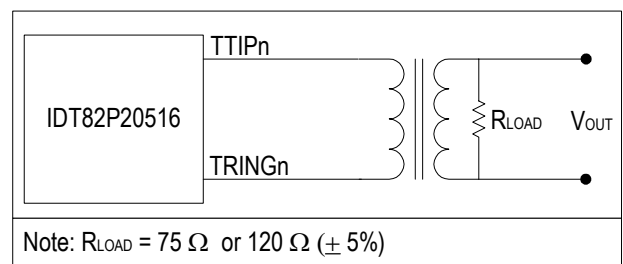
**3.3.4.1 Preset Waveform Template**

In E1 applications, the waveform template meets G.703, as shown in Figure-9. It is measured in the near end line side, as shown in Figure-10.

In E1 applications, the PULS[3:0] should be set to '0000' if differential signals (output from TTIP and TRING) are coupled to a 75 Ω coaxial cable using Internal Impedance matching mode; the PULS[3:0] should be set to '0001' for other E1 interfaces. Refer to Table-5 for details.



**Figure-9 E1 Waveform Template**



**Figure-10 E1 Waveform Template Measurement Circuit**



**Table-5 PULS[3:0] Setting in E1 Mode**

Interface Conditions	PULS[3:0]
E1 75 Ω differential interface, Internal Impedance matching mode	0000
Other E1 interface	0001

After one of the preset waveform templates is selected, the preset waveform amplitude can be adjusted to get the desired waveform.

In E1 mode, the SCAL[5:0] bits (b5~0, SCAL,...) should be set to '100001' to get the standard amplitude. The adjusting is made by increasing or decreasing by '1' from the standard value to scale up or down at a percentage ratio of 3%.

In summary, do the following step by step, the desired waveform will be got based on the preset waveform template:

- Select one preset waveform template by setting the PULS[3:0] bits (b3~0, PULS,...);
- Write '100001' to the SCAL[5:0] bits (b5~0, SCAL,...) if E1 mode is selected.
- Write the scaling value to the SCAL[5:0] bits (b5~0, SCAL,...) to scale the amplitude of the selected preset waveform template (- this step is optional).

**3.3.4.2 User-Programmable Arbitrary Waveform**

When the PULS[3:0] bits (b3~0, PULS,...) are set to '1XXX', user-programmable arbitrary waveform will be used in the corresponding channel.

Each waveform shape can extend up to  $1\frac{1}{4}$  UIs (Unit Interval), and is divided into 20 sub-phases that are addressed by the SAMP[4:0] bits (b4~0, AWG0,...). The waveform amplitude of each phase is represented by a binary byte, within the range from +63 to -63, stored in the WDAT[6:0] bits (b6~0, AWG1,...) in signed magnitude form. The maximum number +63 (D) represents the maximum positive amplitude of the transmit pulse while the most negative number -63 (D) represents the maximum negative amplitude of the transmit pulse. Therefore, up to 20 bytes are used.

There are eight standard templates which are stored in a local ROM. One of them can be selected as reference and made some changes to get the desired waveform.

To do this, the first step is to choose a set of waveform value from the standard templates. The selected waveform value should be the most similar to the desired waveform shape. Table-6 to Table-7 list the sample data of each template.

Then modify the sample data to get the desired transmit waveform shape. By increasing or decreasing by '1' from the standard value in the SCAL[5:0] bits (b5~0, SCAL,...), the waveform amplitude will be scaled up or down.

In summary, do the following for the write operation:

- Modify the sample data in the AWG1 register;
- Write the AWG0 register to implement the write operation, including:
  - Write the sample address to the SAMP[4:0] bits (b4~0, AWG0,...);
  - Write '0' to the RW bit (b5, AWG0,...);
  - Write '1' to the DONE bit (b6, AWG0,...).

Do the following for the read operation:

- Write the AWG0 register, including:
  - Write sample address to the SAMP[4:0] bits (b4~0, AWG0,...);
  - Write '1' to the RW bit (b5, AWG0,...);
  - Write '1' to the DONE bit (b6, AWG0,...);
- Read the AWG1 register to get the sample data.

When the write operation is completed, write the scaling value to the SCAL[5:0] bits (b5~0, SCAL,...) to scale the amplitude of the selected standard waveform (- this step is optional).

When more than one UI is used to compose the waveform template and the waveform amplitude is not set properly, the overlap of the two consecutive waveforms will make the waveform amplitude overflow (i.e., exceed the maximum limitation). This overflow is captured by the DAC\_IS bit (b7, INTS0,...) and will be reported by the INT pin if enabled by the DAC\_IM bit (b7, INTM0,...).

Refer to application note AN-513 'User-Programmable Arbitrary Waveform for DSX1' for more details.

**Table-6 Transmit Waveform Value for E1 75 ohm**

<b>SAMP[4:0]</b>	1	2	3	4	5	6	7	8	9	10	11	12	13	14	15	16	17	18	19	20
<b>WDAT[6:0]</b>	00H	00H	00H	0CH	30H	30H	30H	30H	30H	30H	30H	30H	00H	00H	00H	00H	00H	00H	00H	00H

**Table-7 Transmit Waveform Value for E1 120 ohm**

<b>SAMP[4:0]</b>	1	2	3	4	5	6	7	8	9	10	11	12	13	14	15	16	17	18	19	20
<b>WDAT[6:0]</b>	00H	00H	00H	0FH	3CH	3CH	3CH	3CH	3CH	3CH	3CH	3CH	00H	00H	00H	00H	00H	00H	00H	00H

**3.3.5 LINE DRIVER**

The Line Driver can be set to High-Z for protection or in redundant applications.

The following two ways will set the Line Driver to High-Z:

- Setting the OE pin to low will globally set all the Line Drivers to High-Z;
- Setting the OE bit (b6, TCF0,...) to '0' will set the corresponding Line Driver to High-Z.

By these ways, the functionality of the internal circuit is not affected and TTIPn and TRINGn will enter High-Z state immediately.

**3.3.5.1 Transmit Over Current Protection**

The Line Driver monitors the Transmit Over Current (TOC) on the line interface. When TOC is detected, the driver's output (i.e., output on TTIPn/TRINGn) is determined by the THZ\_OC bit (b4, TCF0,...). If the THZ\_OC bit (b4, TCF0,...) is '0', the driver's output current (peak to peak) is limited to 100 mA; if the THZ\_OC bit (b4, TCF0,...) is '1', the driver's output will enter High-Z. TOC is indicated by the TOC\_S bit (b4, STAT0,...). A transition from '0' to '1' on the TOC\_S bit (b4, STAT0,...) or any transition (from '0' to '1' or from '1' to '0') on the TOC\_S bit (b4, STAT0,...) will set the TOC\_IS bit (b4, INTS0,...) to '1', as selected by the TOC\_IES bit (b4, INTES,...). When the TOC\_IS bit (b4, INTS0,...) is '1', an interrupt will be reported by INT if not masked by the TOC\_IM bit (b4, INTM0,...).

**3.3.6 T<sub>X</sub> TERMINATION**

The transmit line interface supports Transmit Differential mode and Transmit Single Ended mode, as selected by the T\_SING bit (b3, TCF0,...). In Transmit Differential mode, both TTIPn and TRINGn are used to transmit signals to the line side. In Transmit Single Ended mode, only TTIPn is used to transmit signal.

The line interface can be connected with E1 120 Ω twisted pair cable or E1 75 Ω coaxial cable.

The transmit impedance matching is realized by using internal impedance matching or external impedance matching for each channel in different applications.

**3.3.6.1 Transmit Differential Mode**

In Transmit Differential mode, different applications have different impedance matching. For E1 applications, both Internal and External Impedance Matching are supported.

Internal Impedance Matching circuit uses an internal programmable resistor (IM) only.

External Impedance Matching circuit uses an external resistor (Rt) only.

A twisted pair cable can be connected with a 1:2 (step up) transformer or without a transformer (transformer-less), while a coaxial cable must be connected with a 1:2 transformer.

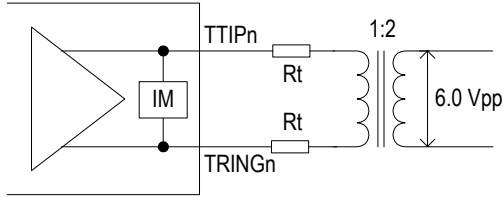
The T\_TERM[2:0] bits (b2~0, TCF0,...) should be set according to different cable conditions, whether a transformer is used, and what kind of Impedance Matching is selected.

Table-8 lists the recommended impedance matching value in different applications. Figure-11 to Figure-13 show the connection for one channel in different applications.

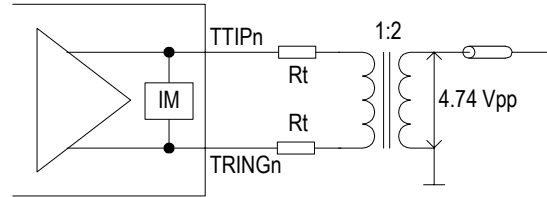
The transformer-less connection will offer a termination option with reduced cost and board space. However, the waveform amplitude is not standard compliant, and surge protection and common mode depression should be enhanced depending on equipment environment.

**Table-8 Impedance Matching Value in Transmit Differential Mode**

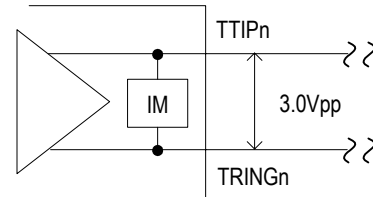
Cable Condition	Internal Impedance Matching			External Impedance Matching		
	T_TERM[2:0]	Rt	PULS[3:0]	T_TERM[2:0]	Rt	PULS[3:0]
E1 120 Ω twisted pair (with transformer)	010	0	0001	111	10 Ω	0000
E1 75 Ω coaxial (with transformer)	011		0000			
E1 120 Ω twisted pair (transformer-less)	110		0001			



**Figure-11 Transmit Differential Line Interface with Twisted Pair Cable (with Transformer)**



**Figure-12 Transmit Differential Line Interface with Coaxial Cable (with transformer)**



**Note:** In this mode, port protection should be enhanced.

**Figure-13 Transmit Differential Line Interface with Twisted Pair Cable (transformer-less, non standard compliant)**

### 3.3.7 TRANSMITTER POWER DOWN

Set the T\_OFF bit (b5, TCF0,...) to '1' will power down the corresponding transmitter.

In this way, the corresponding transmit circuit is turned off. The pins on the transmit line interface (including TTIPn and TRINGn) will be in High-Z state. The input on the transmit system interface (including TDn, TDPn, TDNn and TCLK) is ignored. The output on the transmit system interface will be in High-Z state.

After clearing the T\_OFF bit (b5, TCF0,...), it will take 1 ms for the transmitter to achieve steady state, i.e., return to the previous configuration and performance.

### 3.3.8 OUTPUT HIGH-Z ON TTIP AND TRING

TTIPn and TRINGn can be set to High-Z state globally or on a per-channel basis.

The following three conditions will set TTIPn and TRINGn to High-Z state globally:

- Connecting the OE pin to low;
- Loss of MCLK (i.e., no transition on MCLK for more than 1 ms);
- Power on reset, hardware reset by pulling  $\overline{RST}$  to low for more than 2  $\mu$ s or global software reset by writing the RST register.

The following six conditions will set TTIPn and TRINGn to High-Z state on a per-channel basis:

- Writing '0' to the OE bit (b6, TCF0,...);
- Loss of TCLKn in Transmit Single Rail NRZ Format mode or Transmit Dual Rail NRZ Format mode (i.e., no transition on TCLKn for more than 64 XCLK<sup>1</sup> cycles) except that the channel is in Remote Loopback or transmit internal pattern with XCLK;
- Transmitter power down;
- Per-channel software reset by writing '1' to the CHRST bit (b1, CHCF,...);
- Setting the THZ\_OC bit (b4, TCF0,...) to '1' when transmit driver over-current is detected.

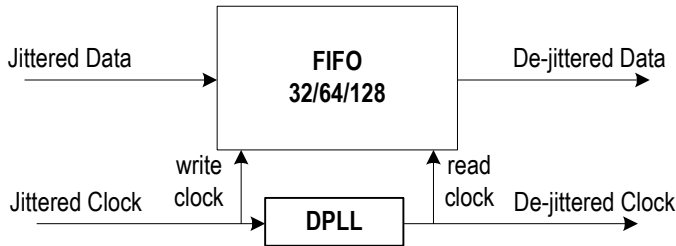
---

1. XCLK is derived from MCLK. It is 2.048 MHz in E1 mode.

### 3.4 JITTER ATTENUATOR (RJA & TJA)

Two Jitter Attenuators are provided for each channel of receiver and transmitter. Each Jitter Attenuator can be enabled or disabled, as determined by the RJA\_EN/TJA\_EN bit (b3, RJA/TJA,...) respectively.

Each Jitter Attenuator consists of a FIFO and a DPLL, as shown in Figure-14.



**Figure-14 Jitter Attenuator**

The FIFO is used as a pool to buffer the jittered input data, then the data is clocked out of the FIFO by a de-jittered clock. The depth of the FIFO can be 32 bits, 64 bits or 128 bits, as selected by the RJA\_DP[1:0]/TJA\_DP[1:0] bits (b2~1, RJA/TJA,...). Accordingly, the typical delay produced by the Jitter Attenuator is 16 bits, 32 bits or 64 bits. The 128-bit FIFO is used when large jitter tolerance is expected, while the 32-bit FIFO is used in delay sensitive applications.

The DPLL is used to generate a de-jittered clock to clock out the data stored in the FIFO. The DPLL can only attenuate the incoming jitter whose frequency is above Corner Frequency (CF) by 20 dB per decade falling off. The jitter whose frequency is lower than the CF passes through the DPLL without any attenuation. In E1 applications, the CF of the DPLL is 6.77 Hz or 0.87 Hz. The CF is selected by the RJA\_BW/TJA\_BW bit (b0, RJA/TJA,...). The lower the CF is, the longer time is needed to achieve synchronization.

If the incoming data moves faster than the outgoing data, the FIFO will overflow. If the incoming data moves slower than the outgoing data, the FIFO will underflow. The overflow and underflow are both captured by the RJA\_IS/TJA\_IS bit (b5/6, INTS0,...). The occurrence of overflow or underflow will be reported by the  $\overline{INT}$  pin if enabled by the RJA\_IM/TJA\_IM bit (b5/6, INTM0,...).

To avoid overflow or underflow, the JA-Limit function can be enabled by setting the RJA\_LIMT/TJA\_LIMT bit (b4, RJA/TJA,...). When the JA-Limit function is enabled, the speed of the outgoing data will be adjusted automatically if the FIFO is 2-bit close to its full or emptiness. Though the JA-Limit function can reduce the possibility of FIFO overflow and underflow, the quality of jitter attenuation is deteriorated.

The performance of the Jitter Attenuator meets ITUT I.431, G.703, G.736-739, G.823, G.824, ETSI 300011, ETSI TBR12/13, AT&T TR62411, TR43802, TR-TSY 009, TR-TSY 253 and TR-TRY 499. Refer to Section 8.10 Jitter Attenuation Characteristics for the jitter performance.

### 3.5 DIAGNOSTIC FACILITIES

The diagnostic facilities include:

- BPV (Bipolar Violation) / CV (Code Violation) detection and BPV insertion;
- EXZ (Excessive Zero) detection;
- LOS (Loss Of Signal) detection;
- AIS (Alarm Indication Signal) detection and generation;
- Pattern generation and detection, including PRBS (Pseudo Random Bit Sequence), ARB (Arbitrary Pattern) and IB (Inband Loop-back).

The above defects, alarms or patterns can be counted by an internal Error Counter, indicated by the respective interrupt bit.

#### 3.5.1 BIPOLAR VIOLATION (BPV) / CODE VIOLATION (CV) DETECTION AND BPV INSERTION

##### 3.5.1.1 Bipolar Violation (BPV) / Code Violation (CV) Detection

BPV/CV is monitored in both the receive path and the transmit path. BPV is detected when the data is AMI coded and CV is detected when the data is B8ZS/HDB3 coded. If the transmit system interface is in Transmit Single Rail NRZ Format mode, the BPV/CV detection is disabled in the transmit path automatically.

A BPV is detected when two consecutive pulses of the same polarity are received.

A CV is detected when two consecutive BPVs of the same polarity that are not a part of the B8ZS/HDB3 zero substitution are received.

When BPV/CV is detected in the receive path, the Line Bipolar Violation LBPV\_IS bit (b4, INTS2,...) will be set and an interrupt will be reported by  $\overline{INT}$  if not masked by the LBPV\_IM bit (b4, INTM2,...).

When BPV/CV is detected in the transmit path, the System Bipolar Violation SBPV\_IS bit (b5, INTS2,...) will be set and an interrupt will be reported by  $\overline{INT}$  if not masked by the SBPV\_IM bit (b5, INTM2,...).

##### 3.5.1.2 Bipolar Violation (BPV) Insertion

The BPV can only be inserted in the transmit path.

A BPV will be inserted on the next available mark in the data stream to be transmitted by writing a '1' to the BPV\_INS bit (b6, ERR,...). This bit will be reset once BPV insertion is done.

#### 3.5.2 EXCESSIVE ZEROES (EXZ) DETECTION

EXZ is monitored in both the receive path and the transmit path.

Different line code has different definition of the EXZ. The IDT82P20516 provides two standards of EXZ definition for each kind of line code rule. The standards are ANSI and FCC, as selected by the EXZ\_DEF bit (b7, ERR,...). Refer to Table-9 for details.

Table-9 EXZ Definition

Line Code Rule	Definition	
	ANSI (EXZ_DEF = 0)	FCC (EXZ_DEF = 1)
AMI	An EXZ is detected when any string of more than 15 consecutive '0's are received.	E1 - An EXZ is detected when any string of more than 15 consecutive '0's are received.
B8ZS	An EXZ is detected when any string of more than 7 consecutive '0's are received.	An EXZ is detected when any string of more than 7 consecutive '0's are received.
HDB3	An EXZ is detected when any string of more than 3 consecutive '0's are received.	An EXZ is detected when any string of more than 3 consecutive '0's are received.
<b>Note:</b> If the transmit system interface is in Transmit Single Rail NRZ Format mode, the EXZ is detected according to the standard of AMI.		

When EXZ is detected in the receive path, the LEXZ\_IS bit (b2, INTS2,...) will be set and an interrupt will be reported by  $\overline{INT}$  if not masked by the LEXZ\_IM bit (b2, INTM2,...).

**3.5.3 LOSS OF SIGNAL (LOS) DETECTION**

The IDT82P20516 detects three kinds of LOS:

- LLOS: Line LOS, detected in the receive path;
- SLOS: System LOS, detected in the transmit system side;
- TLOS: Transmit LOS, detected in the transmit line side.

**3.5.3.1 Line LOS (LLOS)**

The amplitude and density of the data received from the line side are monitored. When the amplitude of the data is less than Q Vpp for N consecutive pulse intervals, LLOS is declared. When the amplitude of the data is more than P Vpp and the average density of marks is at least 12.5% for M consecutive pulse intervals starting with a mark, LLOS is cleared. Here Q is defined by the ALOS[2:0] bits (b6~4, LOS,...). P is the sum of Q and 250 mVpp. N and M are defined by the LAC bit (b7, LOS,...). Refer to Table-10 for details.

In E1 mode, LLOS detection supports G.775 and ETSI 300233/I.431. The criteria are selected by the LAC bit (b7, LOS,...).

When LLOS is detected, the LLOS\_S bit (b0, STAT0,...) will be set. A transition from '0' to '1' on the LLOS\_S bit (b0, STAT0,...) or any transition (from '0' to '1' or from '1' to '0') on the LLOS\_S bit (b0, STAT0,...) will set the LLOS\_IS bit (b0, INTS0,...) to '1', as selected by the LOS\_IES bit (b1, INTES,...). When the LLOS\_IS bit (b0, INTS0,...) is '1', an interrupt will be reported by INT if not masked by the LLOS\_IM bit (b0, INTM0,...).

Two pins (LLOS0 and LLOS) are dedicated to LLOS indication. Whether LLOS is detected in channel 0 or not, LLOS0 is high for a CLKE1 clock cycle to indicate the start position on LLOS. LLOS indicates LLOS status of all 16 channels in a serial format and repeats every 17 cycles. Refer to Figure-15. LLOS0 and LLOS are updated on the rising edge of CLKE1. When the clock output on CLKE1 is disabled, LLOS0 and LLOS will be held in High-Z state. The output on CLKE1 is controlled by the CLKE1\_EN bit (b3, CLKG) and the CLKE1 bit (b2, CLKG). Refer to section 8.9 on page 105 for CLKE1 timing characteristics.

LLOS may be counted by an internal Error Counter. Refer to Section 3.5.6 Error Counter.

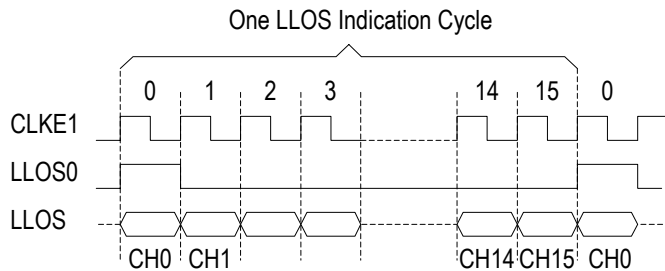
During LLOS, in Receive Single Rail NRZ Format mode, Receive Dual Rail NRZ Format mode and Receive Dual Rail RZ Format mode, RDPn/RDNn output low level. In Receive Dual Rail Sliced mode RDPn/RDNn still output sliced data. RCLKn (if available) outputs high level or XCLK<sup>1</sup>, as selected by the RCKH bit (b7, RCF0,...).

During LLOS, if any of AIS, pattern generation in the receive path or Digital Loopback is enabled or automatic digital loopback happens, RDPn/RDNn and RCLKn output corresponding data and clock, and the setting of the RCKH bit (b7, RCF0,...) is ignored. Refer to the corresponding chapters for details.

1. XCLK is derived from MCLK. It is 2.048 MHz in E1 mode.

**Table-10 LLOS Criteria**

Operation Mode	LAC	Criteria	LLOS Declaring	LLOS Clearing
E1	0	G.775	below Q Vpp, N = 32 bits	above P Vpp, 12.5% mark density with less than 16 consecutive zeros, M = 32 bits
	1	ETSI 300233/ I.431	below Q Vpp, N = 2048 bits	above P Vpp, 12.5% mark density with less than 16 consecutive zeros, M = 32 bits



**Figure-15 LLOS Indication on Pins**



**3.5.3.2 System LOS (SLOS)**

SLOS can only be detected when the transmit system interface is in Dual Rail NRZ Format mode or in Dual Rail RZ Format mode.

The amplitude and density of the data input from the transmit system side are monitored. When the input '0's are equal to or more than N consecutive pulse intervals, SLOS is declared. When the average density of marks is at least 12.5% for M consecutive pulse intervals starting with a mark, SLOS is cleared. Here N and M are defined by the LAC bit (b7, LOS,...). Refer to Table-11 for details.

In E1 mode, SLOS detection supports G.775 and ETSI 300233/ I.431. The criteria are selected by the LAC bit (b7, LOS,...).

When SLOS is detected, the SLOS\_S bit (b1, STAT0,...) will be set. A transition from '0' to '1' on the SLOS\_S bit (b1, STAT0,...) or any transition (from '0' to '1' or from '1' to '0') on the SLOS\_S bit (b1, STAT0,...) will set the SLOS\_IS bit (b1, INTS0,...) to '1', as selected by the LOS\_IES bit (b1, INTES,...). When the SLOS\_IS bit (b1, INTS0,...) is '1', an interrupt will be reported by  $\overline{INT}$  if not masked by the SLOS\_IM bit (b1, INTM0,...).

SLOS may be counted by an internal Error Counter. Refer to Section 3.5.6 Error Counter.

**Table-11 SLOS Criteria**

Operation Mode	LAC	Criteria	SLOS Declaring <sup>1</sup>	SLOS Clearing <sup>1</sup>
E1	0	G.775	no pulse detected for N consecutive pulse intervals, N = 32 bits	12.5% mark density with less than 16 consecutive zeros for M consecutive pulse intervals, M = 32 bits
	1	ETSI 300233/ I.431	no pulse detected for N consecutive pulse intervals, N = 2048 bits	12.5% mark density with less than 16 consecutive zeros for M consecutive pulse intervals, M = 32 bits

**Note:**

1. System input ports are schmitt-trigger inputs)

3.5.3.3 Transmit LOS (TLOS)

The amplitude and density of the data output on the transmit line side are monitored. When the amplitude of the data is less than a certain voltage for a certain period, TLOS is declared. The voltage is defined by the TALOS[1:0] bits (b3~2, LOS,...). The period is defined by the TDLOS[1:0] bits (b1~0, LOS,...). When a valid pulse is detected, i.e., the amplitude is above the setting in the TALOS[1:0] bits (b3~2, LOS,...), TLOS is cleared.

When TLOS is detected, the TLOS\_S bit (b2, STAT0,...) will be set. A transition from '0' to '1' on the TLOS\_S bit (b2, STAT0,...) or any transition (from '0' to '1' or from '1' to '0') on the TLOS\_S bit (b2, STAT0,...) will set the TLOS\_IS bit (b2, INTS0,...) to '1', as selected by the TLOS\_IES bit (b2, INTES,...). When the TLOS\_IS bit (b2, INTS0,...) is '1', an interrupt will be reported by  $\overline{INT}$  if not masked by the TLOS\_IM bit (b2, INTM0,...).

TLOS can be counted by an internal Error Counter. Refer to Section 3.5.6 Error Counter.

TLOS can be used to monitor the LOS in the transmit line side between two channels. The connection between the two channels is shown in Figure-16. The two channels can be of the same device or different devices on the premises that the transmit line interfaces are in the same mode and at least the output of one channel is in High-Z state. Table-12 lists each results in this case. In the left two columns, the OE bit (b6, TCF0,...) of the two channels controls the output status in the transmit line side to ensure that at least one channel is in High-Z state.

The middle two columns list the internal operation status. In the right two columns, the TLOS\_S bit (b2, STAT0,...) of the two channels indicates the TLOS status in the transmit line side.

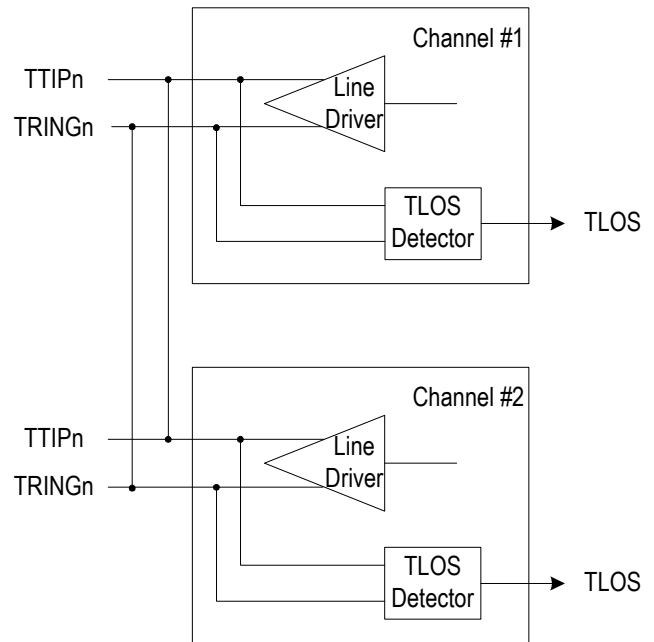


Figure-16 TLOS Detection Between Two Channels

Table-12 TLOS Detection Between Two Channels

Output Status ~ Controlled By the OE Bit		Internal Operation Status		TLOS Status ~ Indicated By the TLOS_S Bit	
Channel #1	Channel #2	Channel #1	Channel #2	Channel #1	Channel #2
Normal ~ 1	High-Z ~ 0	Normal	(don't-care)	No TLOS ~ 0	No TLOS ~ 0
Normal ~ 1	High-Z ~ 0	Failure	Normal	TLOS Detected ~ 1 *	TLOS Detected ~ 1
High-Z ~ 0	Normal ~ 1	(don't-care)	Normal	No TLOS ~ 0	No TLOS ~ 0
High-Z ~ 0	Normal ~ 1	Normal	Failure	TLOS Detected ~ 1	TLOS Detected ~ 1 *
High-Z ~ 0	High-Z ~ 0	(don't-care)	(don't-care)	TLOS Detected ~ 1	TLOS Detected ~ 1

Note:

\* The TLOS\_S bit (b2, STAT0,...) may not be set if there is any catastrophic failure in the channel.

**3.5.4 ALARM INDICATION SIGNAL (AIS) DETECTION AND GENERATION**

**3.5.4.1 Alarm Indication Signal (AIS) Detection**

AIS is monitored in both the receive path and the transmit path.

When the mark density in the received data or in the data input from the transmit system side meets certain criteria, AIS is declared or cleared. In E1 mode, the criteria are in compliance with ITU G.775 or ETSI 300233, as selected by the LAC bit (b7, LOS,...). Refer to Table-13 for details.

**Table-13 AIS Criteria**

	ITU G.775 for E1 (LAC = 0)	ETSI 300233 for E1 (LAC = 1)
<b>AIS Declaring</b>	Less than 3 zeros are received in each of two consecutive 512-bit data streams.	Less than 3 zeros are received in a 512-bit data stream.
<b>AIS Clearing</b>	3 or more zeros are received in each of two consecutive 512-bit data streams.	3 or more zeros are received in a 512-bit data stream.

When AIS is detected in the receive path, the LAIS\_S bit (b6, STAT1,...) will be set. A transition from '0' to '1' on the LAIS\_S bit (b6, STAT1,...) or any transition (from '0' to '1' or from '1' to '0') on the LAIS\_S bit (b6, STAT1,...) will set the LAIS\_IS bit (b6, INTS1,...) to '1', as selected by the AIS\_IES bit (b6, INTES,...). When the LAIS\_IS bit (b6, INTS1,...) is '1', an interrupt will be reported by  $\overline{INT}$  if not masked by the LAIS\_IM bit (b6, INTM1,...).

When AIS is detected in the transmit path, the SAIS\_S bit (b7, STAT1,...) will be set. A transition from '0' to '1' on the SAIS\_S bit (b7, STAT1,...) or any transition (from '0' to '1' or from '1' to '0') on the SAIS\_S bit (b7, STAT1,...) will set the SAIS\_IS bit (b7, INTS1,...) to '1', as selected by the AIS\_IES bit (b6, INTES,...). When the SAIS\_IS bit (b7, INTS1,...) is '1', an interrupt will be reported by  $\overline{INT}$  if not masked by the SAIS\_IM bit (b7, INTM1,...).

AIS may be counted by an internal Error Counter. Refer to Section 3.5.6 Error Counter.

**3.5.4.2 (Alarm Indication Signal) AIS Generation**

AIS can be generated automatically in the receive path and the transmit path.

In the receive path, when the AS AIS\_LLOS bit (b2, AISG,...) is set, AIS will be generated automatically once LLOS is detected. When the AS AIS\_SLOS bit (b3, AISG,...) is set, AIS will be generated automatically once SLOS is detected. When AIS is generated, RDPn/RDNn output all '1's. RCLKn (if available) outputs XCLK.

In the transmit path, when the ALAIS\_LLOS bit (b0, AISG,...) is set, AIS will be generated automatically once LLOS is detected. When the ALAIS\_SLOS bit (b1, AISG,...) is set, AIS will be generated automatically once SLOS is detected. When AIS is generated, TTIPn/TRINGn output all '1's.

In the transmit path, the AIS transmission is controlled by the TXAIS bit (b4, AISG,...). When the TXAIS bit (b4, AISG,...) is set to '1', all '1's pattern is transmitted at TTIPn/TRINGn.

AIS generation uses XCLK<sup>1</sup> as reference clock.

If pattern (including PRBS, ARB and IB) is generated in the same direction, the priority of pattern generation is higher. The generated pattern will overwrite automatic AIS. Refer to Section 3.5.5.1 Pattern Generation for the output data and clock.

1. XCLK is derived from MCLK. It is 2.048 MHz in E1 mode.

**3.5.5 PRBS, QRSS, ARB AND IB PATTERN GENERATION AND DETECTION**

The pattern includes: Pseudo Random Bit Sequence (PRBS), Quasi-Random Signal Source (QRSS), Arbitrary Pattern (ARB) and Inband Loopback (IB).

**3.5.5.1 Pattern Generation**

The pattern can be generated in the receive path or the transmit path, as selected by the PG\_POS bit (b3, PG,...).

The pattern to be generated is selected by the PG\_EN[1:0] bits (b5~4, PG,...).

If PRBS is selected, three kinds of PRBS patterns with maximum zero restriction according to ITU-T O.151 and AT&T TR62411 are provided. They are: (2<sup>20</sup> - 1) QRSS per O.150-4.5, (2<sup>15</sup> - 1) PRBS per O.152 and (2<sup>11</sup> - 1) PRBS per O.150, as selected by the PRBG\_SEL[1:0] bits (b1~0, PG,...).

If ARB is selected, the content is programmed in the ARB[23:0] bits (b7~0, ARBH~ARBM~ARBL,...).

If IB is selected, the length of the IB code can be 3 to 8 bits, as determined by the IBGL[1:0] bits (b5~4, IBL,...). The content is programmed in the IBG[7:0] bits (b7~0, IBG,...).

The selected pattern is transmitted repeatedly until the PG\_EN[1:0] bits (b5~4, PG,...) is set to '00'.

When pattern is generated in the receive path, the reference clock is XCLK or the recovered clock from the received signal, as selected by the PG\_CK bit (b6, PG,...). The selected reference clock is also output on RCLKn (if available).

When pattern is generated in the transmit path, the reference clock is XCLK<sup>1</sup> or the transmit clock, as selected by the PG\_CK bit (b6, PG,...). The transmit clock refers to the clock input on TCLKn (in Transmit Single Rail NRZ Format mode and in Transmit Dual Rail NRZ Format mode) or the clock recovered from the data input on TDPn and TDNn (in Transmit Dual Rail RZ Format mode).

In summary, do the followings step by step to generate pattern:

- Select the generation direction by the PG\_POS bit (b3, PG,...);
- Select the reference clock by the PG\_CK bit (b6, PG,...);
- Select the PRBS pattern by the PRBG\_SEL[1:0] bits (b1~0, PG,...) when PRBS is to be generated; program the ARB pattern in the ARB[23:0] bits (b7~0, ARBH~ARBM~ARBL,...) when ARB is to be generated; or set the length and the content of the IB code in the IBGL[1:0] bits (b5~4, IBL,...) and in the IBG[7:0] bits (b7~0, IBG,...) respectively when IB is to be generated;
- Set the PG\_EN[1:0] bits (b5~4, PG,...) to generate the pattern.

1. XCLK is derived from MCLK. It is 2.048 MHz in E1 mode.

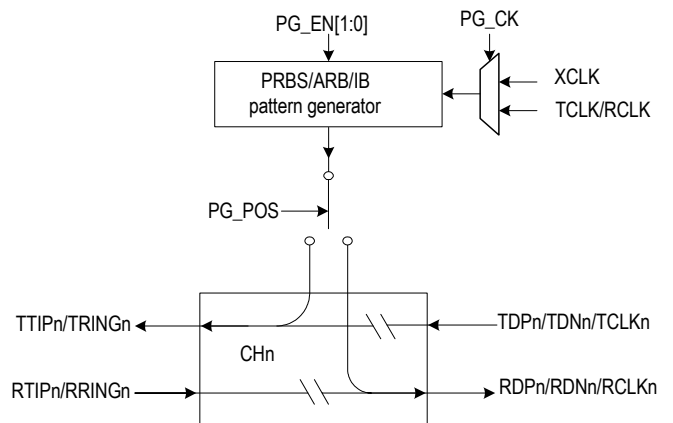
If PRBS or ARB is selected to be generated, the following two steps can be optionally implemented after the pattern is generated:

- Insert a single bit error by writing '1' to the ERR\_INS bit (b5, ERR,...);
- Invert the generated pattern by setting the PAG\_INV bit (b2, PG,...).

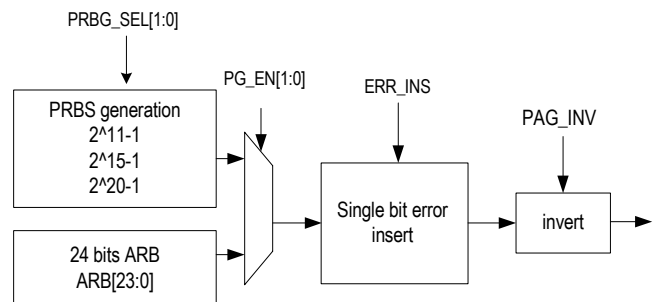
If pattern is generated in the receive path, the generated pattern should be encoded by using AMI or HDB3 (for E1) in Receive Dual Rail NRZ Format mode, Receive Dual Rail RZ Format mode and Receive Dual Rail Sliced mode. The encoding rule is selected by the R\_CODE bit (b2, RCF1,...).

If pattern is generated in the transmit path, the generated pattern should be encoded by using AMI or HDB3 (for E1). The encoding rule is selected by the T\_CODE bit (b2, TCF1,...).

The pattern generation is shown in Figure-17 and Figure-18.



**Figure-17 Pattern Generation (1)**



**Figure-18 Pattern Generation (2)**

The priority of pattern generation is higher than that of AIS generation. If they are generated in the same direction, the generated pattern will overwrite the generated AIS.

**3.5.5.2 Pattern Detection**

Data received from the line side or data input from the transmit system side may be extracted for pattern detection. The direction of data extraction is determined by the PD\_POS bit (b3, PD,...). One of PRBS or ARB pattern is selected for detection and IB detection is always active.

If data is extracted from the receive path, before pattern detection the data should be decoded by using AMI or HDB3 (for E1). The decoding rule is selected by the R\_CODE bit (b2, RCF1,...).

If data is extracted from the transmit path, before pattern detection the data should be decoded by using AMI or HDB3 (for E1) in Transmit Dual Rail NRZ Format mode and Transmit Dual Rail RZ Format mode. The decoding rule is selected by the T\_CODE bit (b2, TCF1,...).

**Pseudo Random Bit Sequence (PRBS) /Arbitrary Pattern (ARB) Detection**

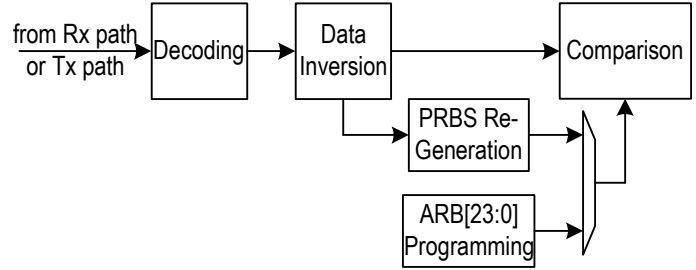
The extracted data can be optionally inverted by the PAD\_INV bit (b2, PD,...) before PRBS/ARB detection.

The extracted data is used to compare with the desired pattern. The desired pattern is re-generated from the extracted data if the desired pattern is (2<sup>20</sup> - 1) QRSS per O.150-4.5, (2<sup>15</sup> - 1) PRBS per O.152 or (2<sup>11</sup> - 1) PRBS per O.150; or the desired pattern is programmed in the ARB[23:0] bits (b7~0, ARBH~ARBM~ARBL,...) if the desired pattern is ARB. The desired pattern is selected by the PAD\_SEL[1:0] bits (b1~0, PD,...).

In summary, do the followings step by step to detect PRBS/ARB:

- Select the detection direction by the PD\_POS bit (b3, PD,...);
- Set the ARB[23:0] bits (b7~0, ARBH~ARBM~ARBL,...) if the ARB pattern is desired - this step is omitted if the PRBS pattern is desired;
- Select the desired PRBS/ARB pattern by the PAD\_SEL[1:0] bits (b1~0, PD,...).

The priority of decoding, data inversion, pattern re-generation, bit programming and pattern comparison is shown in Figure-19.



**Figure-19 PRBS / ARB Detection**

During comparison, if the extracted data coincides with the re-generated PRBS pattern or the programmed ARB pattern for more than 64-bit hopping window, the pattern is synchronized and the PA\_S bit (b5, STAT1,...) will be set.

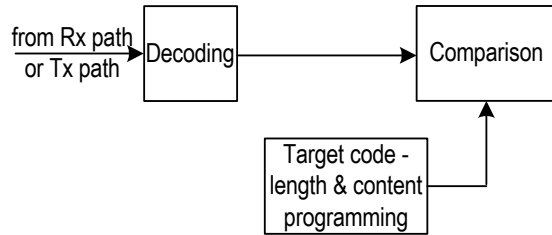
In synchronization state, if more than 6 PRBS/ARB errors are detected in a 64-bit hopping window, the pattern is out of synchronization and the PA\_S bit (b5, STAT1,...) will be cleared.

In synchronization state, each mismatched bit will generate a PRBS/ARB error. When a PRBS/ARB error is detected during the synchronization, the ERR\_IS bit (b1, INTS2,...) will be set and an interrupt will be reported by INT if not masked by the ERR\_IM bit (b1, INTM2,...). The PRBS/ARB error may be counted by an internal Error Counter. Refer to Section 3.5.6 Error Counter.

A transition from '0' to '1' on the PA\_S bit (b5, STAT1,...) or any transition (from '0' to '1' or from '1' to '0') on the PA\_S bit (b5, STAT1,...) will set the PA\_IS bit (b5, INTS1,...) to '1', as selected by the PA\_IES bit (b5, INTES,...). When the PA\_IS bit (b5, INTS1,...) is '1', an interrupt will be reported by INT if not masked by the PA\_IM bit (b5, INTM1,...).

**Inband Loopback (IB) Detection**

The extracted data is used to compare with the target IB code. The length of the target activate/deactivate IB code can be 3 to 8 bits, as determined by the IBAL[1:0]/IBDL[1:0] bits (b3~2/b1~0, IBL,...). The content of the target activate/deactivate IB code is programmed in the IBA[7:0]/IBD[7:0] bits (b7~0, IBDA/IBDD,...). Refer to Figure-20.



**Figure-20 IB Detection**

During comparison, if the extracted data coincides with the target activate/deactivate IB code with no more than 10<sup>-2</sup> bit error rate for a certain period, the IB code is detected. The period depends on the setting of the AUTOLP bit (b3, LOOP,...).

If the AUTOLP bit (b3, LOOP,...) is '0', Automatic Digital/Remote Loopback is disabled. In this case, when the activate IB code is detected for more than 40 ms, the IBA\_S bit (b1, STAT1,...) will be set to indicate the activate IB code detection; when the deactivate IB code is detected for more than 40 ms (T1/J1 mode) / 30 ms (E1 mode), the IBD\_S bit (b0, STAT1,...) will be set to indicate the deactivate IB code detection.

If the AUTOLP bit (b3, LOOP,...) is '1', Automatic Digital/Remote Loopback is enabled. In this case, when the activate IB code is detected for more than 5.1 seconds, the IBA\_S bit (b1, STAT1,...) will be set to indicate the activate IB code detection. The detection of the activate IB code in the receive path will activate Remote Loopback or the detection of the activate IB code in the transmit path will activate Digital Loopback (refer to Section 3.5.7.2 Remote Loopback & Section 3.5.7.3 Digital Loopback). When the deactivate IB code is detected for more than 5.1 seconds, the IBD\_S bit (b0, STAT1,...) will be set to indicate the deactivate IB code detection. The detection of the deactivate IB code in the receive path will deactivate Remote Loopback or the detection of the deactivate IB code in the transmit path will deactivate Digital Loopback (refer to Section 3.5.7.2 Remote Loopback & Section 3.5.7.3 Digital Loopback).

A transition from '0' to '1' on the IBA\_S/IBD\_S bit (b1/b0, STAT1,...) or any transition (from '0' to '1' or from '1' to '0') on the IBA\_S/IBD\_S bit (b1/b0, STAT1,...) will set the IBA\_IS/IBD\_IS bit (b1/b0, INTS1,...) to '1'

respectively, as selected by the IB\_IES bit (b0, INTES,...). When the IBA\_IS/IBD\_IS bit (b1/b0, INTS1,...) is '1', an interrupt will be reported on  $\overline{INT}$  if not masked by the IBA\_IM/IBD\_IM bit (b1/b0, INTM1,...).

**3.5.6 ERROR COUNTER**

An internal 16-bit Error Counter is used to count one of the following errors:

- LBPV: BPV/CV detected in the receive path (line side);
- LEXZ: EXZ detected in the receive path (line side);
- LBPV + LEXZ: BPV/CV and EXZ detected in the receive path (line side);
- SBPV: BPV/CV detected in the transmit path (system side) (disabled in Transmit Single Rail NRZ Format mode);
- SEXZ: EXZ detected in the transmit path (system side);
- SBPV + SEXZ: BPV/CV and EXZ detected in the transmit path (system side) (disabled in Transmit Single Rail NRZ Format mode);
- PRBS/ARB error.

The CNT\_SEL[2:0] bits (b4~2, ERR,...) select one of the above errors to be counted.

The Error Counter is buffered. It is updated automatically or manually, as determined by the CNT\_MD bit (b1, ERR,...).

The Error Counter is accessed by reading the ERRCH and ERRCL registers.

**3.5.6.1 Automatic Error Counter Updating**

When the CNT\_MD bit (b1, ERR,...) is '1', the Error Counter is updated every one second automatically.

The one-second timer uses MCLK as clock reference. The expiration of each one second will set the TMOV\_IS bit (b0, INTTM) and induce an interrupt reported by  $\overline{INT}$  if not masked by the TMOV\_IM bit (b0, GCF).

When each one second expires, the Error Counter transfers the accumulated error numbers to the ERRCH and ERRCL registers and the Error Counter will be cleared to start a new round counting. The ERRCH and ERRCL registers should be read in the next second, otherwise they will be overwritten.

When the ERRCH and ERRCL registers are all '1's and there is still error to be accumulated, the registers will be overflowed. The overflow is indicated by the CNTOV\_IS bit (b0, INTS2,...) and will induce an interrupt reported by  $\overline{INT}$  if not masked by the CNTOV\_IM (b0, INTM2,...).

The process of automatic Error Counter updating is illustrated in Figure-21.

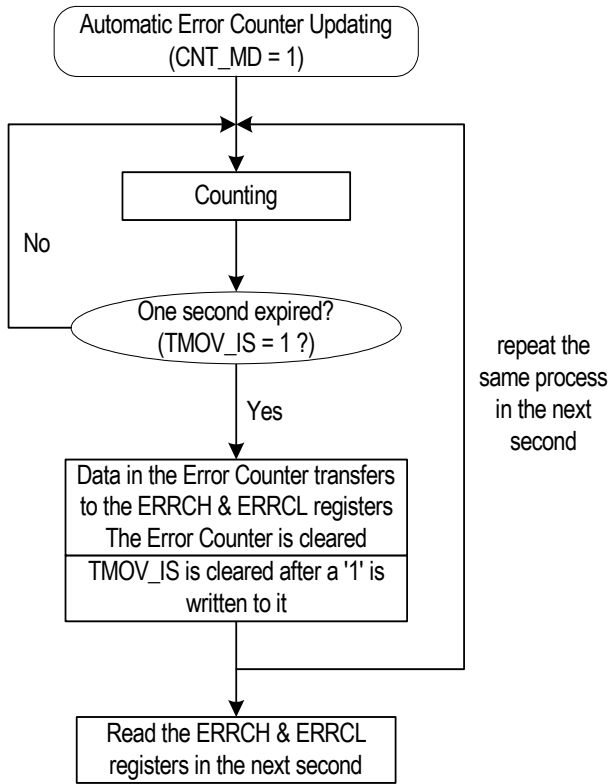


Figure-21 Automatic Error Counter Updating

### 3.5.6.2 Manual Error Counter Updating

When the CNT\_MD bit (b1, ERR,...) is '0', the Error Counter is updated manually.

When there is a transition from '0' to '1' on the CNT\_STOP bit (b0, ERR,...), the Error Counter transfers the accumulated error numbers to the ERRCH and ERRCL registers and the Error Counter will be cleared to start a new round counting. The ERRCH and ERRCL registers should be read in the next round of error counting, otherwise they will be overwritten.

When the ERRCH and ERRCL registers are all '1's and there is still error to be accumulated, the registers will be overflowed. The overflow is indicated by the CNTOV\_IS bit (b0, INTS2,...) and will induce an interrupt reported by INT if not masked by the CNTOV\_IM (b0, INTM2,...).

The process of manual Error Counter updating is illustrated in Figure-22.

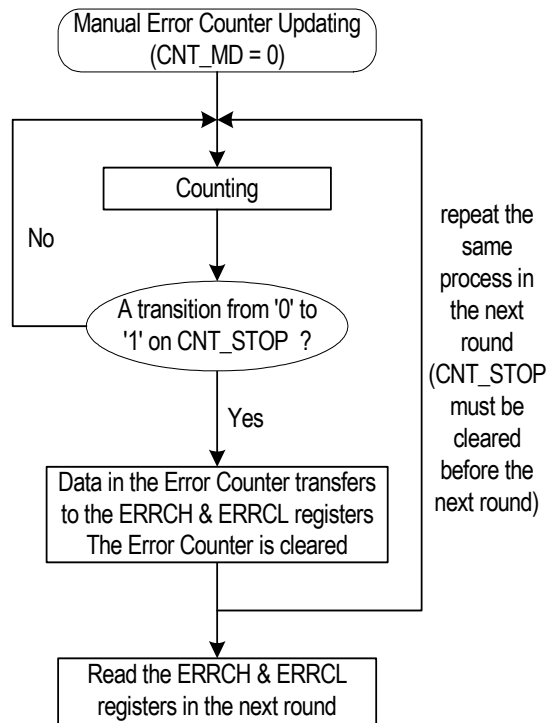


Figure-22 Manual Error Counter Updating



3.5.7 LOOPBACK

There are four kinds of loopback:

- Analog Loopback
- Remote Loopback
- Digital Loopback

Refer to Figure-1 for loopback location.

3.5.7.1 Analog Loopback

Analog Loopback is enabled by the ALP bit (b0, LOOP,...). The data stream to be transmitted on the TTIPn/TRINGn pins is internally looped to the RTIPn/RRINGn pins.

In Analog Loopback mode, the data stream to be transmitted is still output to the line side, while the data stream received from the line side is covered by the Analog Loopback data.

Anytime when Analog Loopback is set, the other loopbacks (i.e., Digital Loopback and Remote Loopback) are disabled.

In Analog Loopback, the priority of the diagnostic facilities in the receive path is: pattern generation > looped data. AIS generation is disabled in both the receive path and the transmit path. Refer to Figure-23.

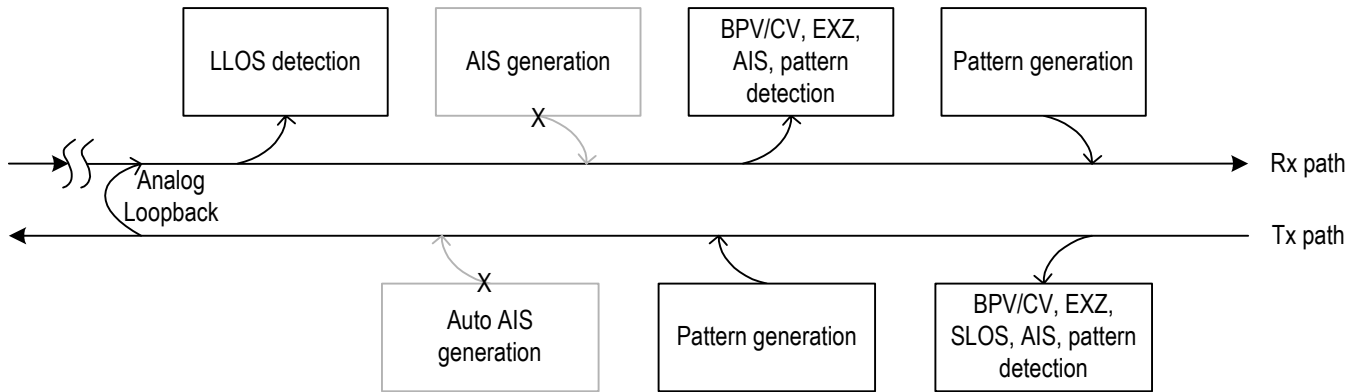


Figure-23 Priority Of Diagnostic Facilities During Analog Loopback



**3.5.7.2 Remote Loopback**

Remote Loopback can be configured manually or automatically. Either manual Remote Loopback configuration or automatic Remote Loopback configuration will enable Remote Loopback.

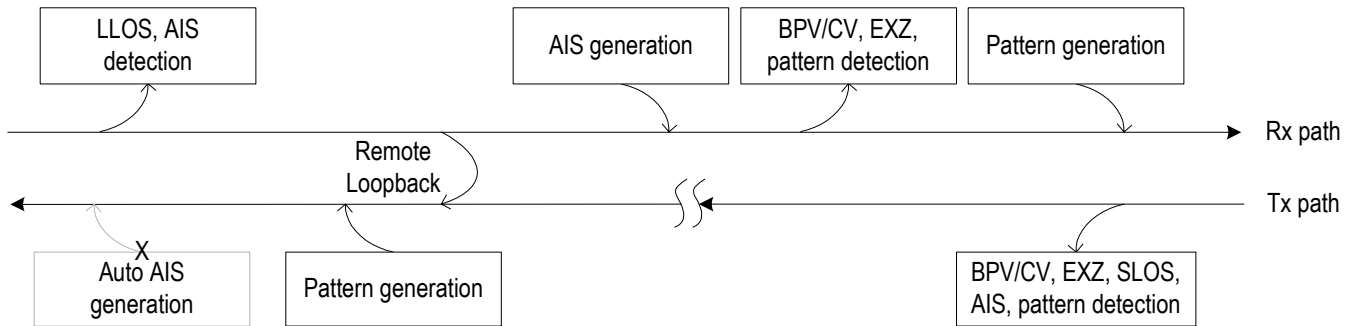
Manual Remote Loopback is enabled by the RLP bit (b1, LOOP,...).

Automatic Remote Loopback is enabled when the pattern detection is assigned in the receive path (i.e., the PD\_POS bit (b3, PD,...) is '0') and the AUTOLP bit (b3, LOOP,...) is '1'. The corresponding channel will enter Remote Loopback when the activate IB code is detected in the receive path for more than 5.1 sec.; and will return from Remote Loopback when the deactivate IB code is detected in the receive path for more than 5.1 sec. Refer to section Inband Loopback (IB) Detection on page 38 for details. When automatic Remote Loopback is active, setting the AUTOLP bit (b3, LOOP,...) back to '0' will also stop automatic

Remote Loopback. The setting of the PD\_POS bit (b3, PD,...) should not be changed during automatic Remote Loopback. The AUTOLP\_S bit (b7, STAT0,...) indicates the automatic Remote Loopback status.

In Remote Loopback mode, the data stream output from the RJA (if enabled) is internally looped to the Waveform Shaper. The data stream received from the line side is still output to the system side, while the data stream input from the system side is covered by the Remote Loopback data and the status on TCLKn does not affect the Remote Loopback. However, the BPV/CV, EXZ, SLOS, AIS and pattern detection in the transmit path still monitors the data stream input from the system side.

In Remote Loopback mode, the priority of the diagnostic facilities in the receive path is: pattern generation > AIS generation; the priority of the diagnostic facilities in the transmit path is: pattern generation > looped data. AIS generation is disabled in the transmit path. Refer to Figure-24.



**Figure-24 Priority Of Diagnostic Facilities During Manual Remote Loopback**

**3.5.7.3 Digital Loopback**

The Digital Loopback can be configured manually or automatically. Either manual Digital Loopback configuration or automatic Digital Loopback configuration will enable Digital Loopback.

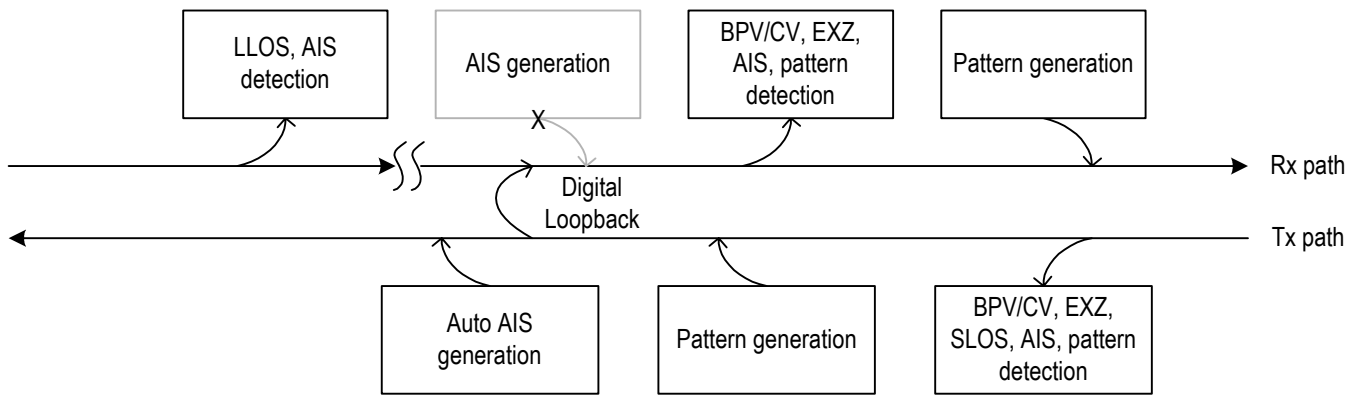
Manual Digital Loopback is enabled by the DLP bit (b2, LOOP,...).

Automatic Digital Loopback is enabled when the pattern detection is assigned in the transmit path (i.e., the PD\_POS bit (b3, PD,...) is '1') and the AUTOLP bit (b3, LOOP,...) is '1'. The corresponding channel will enter Digital Loopback when the activate IB code is detected in the transmit path for more than 5.1 sec.; and will return from Digital Loopback when the deactivate IB code is detected in the transmit path for more than 5.1 sec. Refer to section Inband Loopback (IB) Detection on page 38 for details. When automatic Digital Loopback is active, setting the AUTOLP bit (b3, LOOP,...) back to '0' will also stop automatic Digital

Loopback. The setting of the PD\_POS bit (b3, PD,...) should not be changed during automatic Digital Loopback. The AUTOLP\_S bit (b7, STAT0,...) indicates the automatic Digital Loopback status.

In Digital Loopback mode, the data stream output from the TJA (if enabled) is internally looped to the Decoder (if enabled). The data stream to be transmitted is still output to the line side, while the data stream received from the line side is covered by the Digital Loopback data. However, LLOS and AIS detection in the receive path still monitors the data stream received from the line side.

In Digital Loopback mode, the priority of the diagnostic facilities in the receive path is: pattern generation > looped data; the priority of the diagnostic facilities in the transmit path is: pattern generation > looped data > AIS generation. AIS generation is disabled in the receive path.



**Figure-25 Priority Of Diagnostic Facilities During Digital Loopback**

**3.5.8 CHANNEL 0 MONITORING**

Channel 0 can be used as a monitoring channel when not used as a regular channel. Channel 0 support G.772 Monitoring and Jitter Measurements.

**3.5.8.1 G.772 Monitoring**

Selected by the MON[5:0] bits (b5~0, MON), any receiver or transmitter of the other 15 channels can be monitored by channel 0 (as shown in Figure-26).

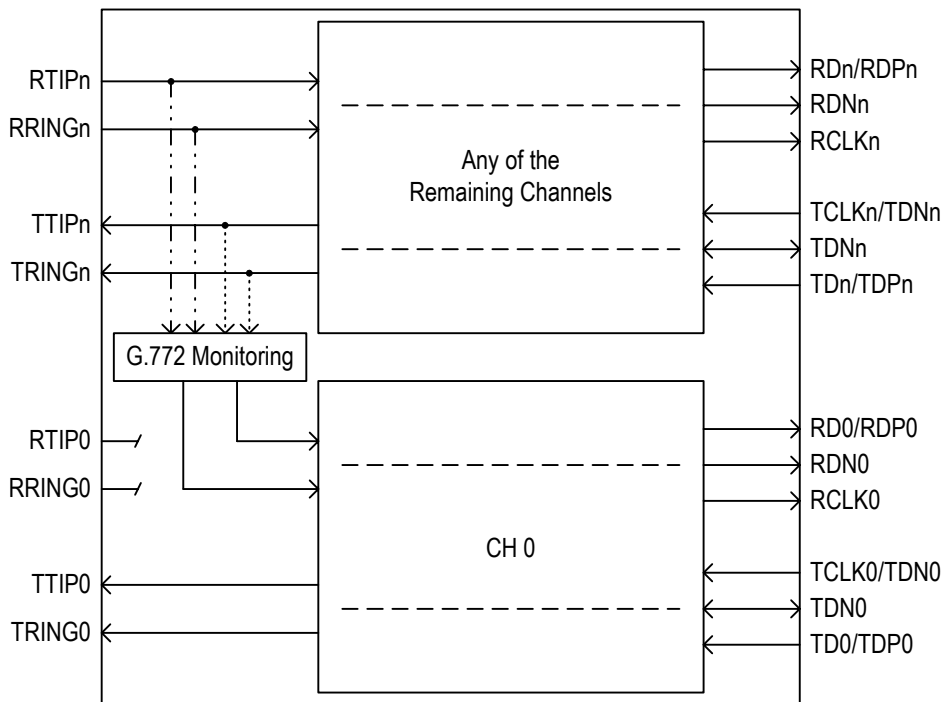
When the G.772 Monitoring is implemented (the MON[5:0] bits (b5~0, MON) is not '0'), the registers of the receiver of channel 0 should be the same as those of the selected receiver /transmitter except the line interface related registers.

Once the G.772 Monitoring is implemented, the receiver of channel 0 switches to External Impedance Matching mode automatically, and the setting in the R\_TERM[2:0] bits (b2~0, RCF0,...) of channel 0 is ignored.

During the G.772 Monitoring, channel 0 processes as normal after data is received from the selected path and the operation of the monitored path is not effected.

The signal which is monitored goes through the Clock & Data Recovery of monitoring channel (channel 0). The monitored clock can output on RCLK0. The monitored data can be observed digitally on the output pin of RCLK0, RD0/RDP0 and RDN0. LOS detector is still in use in channel 0 for the monitored signal.

In monitoring mode, channel 0 can be configured to Remote Loop-back. The signal which is being monitored will output on TTIP0 and TRING0. The output signal can then be connected to a standard test equipment for non-intrusive monitoring.



**Figure-26 G.772 Monitoring**

3.5.8.2 Jitter Measurement (JM)

The RJA of channel 0 consists of a Jitter Measurement (JM) module. When the RJA is enabled in channel 0, the JM is used to measure the positive and negative peak value of the demodulated jitter signal of the received data stream. The bandwidth of the measured jitter is selected by the JM\_BW bit (b0, JM).

The greatest positive peak value monitored in a certain period is indicated by the JIT\_PH and JIT\_PL registers, while the greatest negative peak value monitored in the same period is indicated by the JIT\_NH and JIT\_NL registers. The relationship between the greatest positive /negative peak value and the indication in the corresponding registers is:

$$\text{Positive Peak} = [\text{JIT\_PH}, \text{JIT\_PL}] / 16 (\text{Upp});$$

$$\text{Negative Peak} = [\text{JIT\_NH}, \text{JIT\_NL}] / 16 (\text{Upp}).$$

The period is determined by the JM\_MD bit (b1, JM).

When the JM\_MD bit (b1, JM) is '1', the period is one second automatically. The one-second timer uses MCLK as clock reference. The expiration of each one second will set the TMOV\_IS bit (b0, INTTM) and induce an interrupt reported by INT if not masked by the TMOV\_IM bit (b0, GCF). The TMOV\_IS bit (b0, INTTM) is cleared after a '1' is written to this bit. When each one second expires, internal buffers transfer the greatest positive/negative peak value accumulated in this one second to the JIT\_PH and JIT\_PL / JIT\_NH and JIT\_NL registers respectively and the internal buffers will be cleared to start a new round measurement. The registers should be read in the next second, otherwise they will be overwritten. Refer to Figure-27 for the process.

When the JM\_MD bit (b1, JM) is '0', the period is controlled by the JM\_STOP bit (b2, JM) manually. When there is a transition from '0' to '1' on the JM\_STOP bit (b2, JM), the internal buffers transfer the greatest positive/negative peak value accumulated in this period to the JIT\_PH and JIT\_PL / JIT\_NH and JIT\_NL registers respectively and the internal buffers will be cleared to start a new round measurement. The registers should be read in the next round of jitter measurement, otherwise they will be overwritten. Refer to Figure-28 for the process.

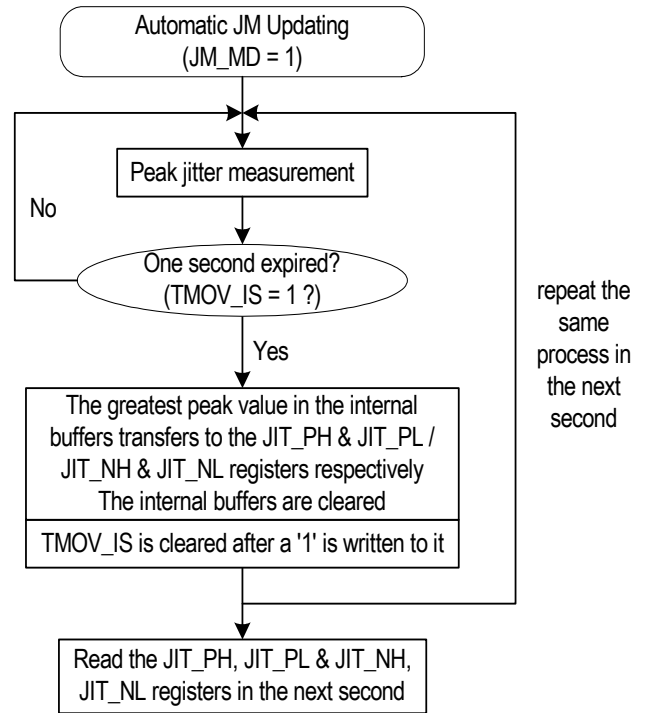


Figure-27 Automatic JM Updating

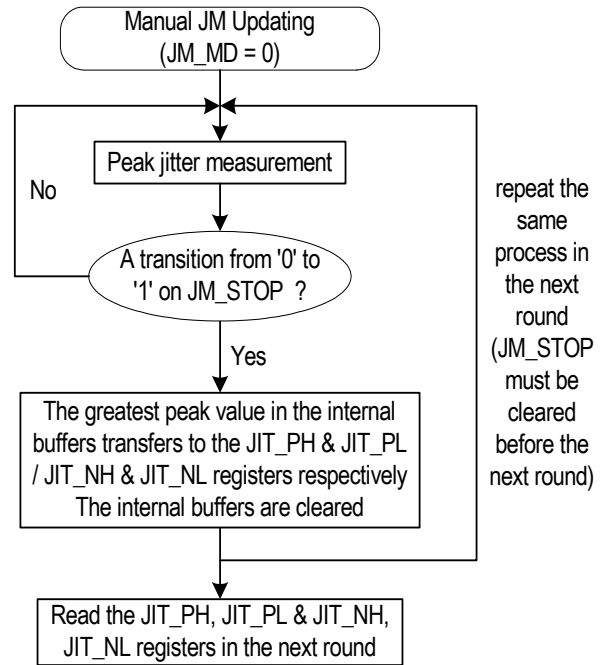


Figure-28 Manual JM Updating

### 3.6 CLOCK INPUTS AND OUTPUTS

The IDT82P20516 provides two kinds of clock outputs:

- Free running clock outputs on CLKE1

The following Clock Input is provided:

- MCLK as programmable reference timing for the IDT82P20516.

#### 3.6.1 FREE RUNNING CLOCK OUTPUTS ON CLKE1

An internal clock generator uses MCLK as reference to generate all the clocks required by internal circuits and CLKE1 outputs. MCLK should be a clock with +/-50 ppm (in E1 mode) accuracy. The clock frequency of MCLK is  $1.544/2.048 \times N$  MHz ( $1 \leq N \leq 8$ , N is an integer number), as determined by MCKSEL[3:0]. Refer to Chapter 2 Pin Description for details.

The outputs on CLKE1 are free running (locking to MCLK). The output of CLKE1 is determined by the CLKE1\_EN bit (b3, CLKG) and the CLKE1 bit (b2, CLKG). Refer to Table-14.

**Table-14 Clock Output on CLKE1**

Control Bits		Clock Output On CLKE1
CLKE1_EN	CLKE1	
0	(don't-care)	High-Z
1	0	8 KHz
	1	2.048 KHz

**3.6.2 MCLK, MASTER CLOCK INPUT**

MCLK provides a stable reference timing for the IDT82P20516. MCLK should be a clock with +/-50 ppm (in E1 mode) accuracy. The clock frequency of MCLK is set by pins MCKSEL[3:0] and can be N x 1.544 MHz or N x 2.048 MHz with  $1 \leq N \leq 8$  (N is an integer number). Refer to MCKSEL[3:0] pin description for details.

If there is a loss of MCLK (duty cycle is less than 30% for 10  $\mu$ s), the device will enter power down. In this case, both the receive and transmit circuits are turned off. The pins on the line interface will be in High-Z state. The pins on receive system interface will be in High-Z state or in low level, as selected by the RHZ bit (b6, RCF0,...). The input on the

transmit system interface is ignored and the output on the transmit system interface will be in High-Z state. Refer to Section 3.2.7 Receiver Power Down and Section 3.3.7 Transmitter Power Down for details.

If MCLK recovers after loss of MCLK the device will be reset automatically.

**3.6.3 XCLK, INTERNAL REFERENCE CLOCK INPUT**

XCLK is derived from MCLK. For the respective channel, it is 2.048 MHz in E1 mode. XCLK is used as selectable reference clock for

- pattern /AIS generation
- RCLKn in LLOS
- Loss of TCLKn to determine Transmit Output High-Z.

### 3.7 INTERRUPT SUMMARY

There are altogether 20 kinds of interrupt sources as listed in Table-15. Among them, No.1 to No.19 are per-channel interrupt sources, while No. 20 is a global interrupt source.

For interrupt sources from No.1 to No.10, the occurrence of the event will cause the corresponding Status bit to be set to '1'. And selected by the Interrupt Trigger Edges Select bit, either a transition from '0' to '1' or any transition from '0' to '1' or from '1' to '0' of the Status bit will cause the Interrupt Status bit to be set to '1', which indicates the occurrence of an interrupt event.

For interrupt sources from No.11 to No.20, the occurrence of the event will cause the corresponding Interrupt Status Bit to be set to '1'.

All the interrupt can be masked by the GLB\_IM bit (b1, GCF) globally or by the corresponding interrupt mask bit individually. For all the interrupt sources, if not masked, the occurrence of the interrupt event will trigger an interrupt indicated by the  $\overline{INT}$  pin. For per-channel interrupt sources, if not masked, the occurrence of the interrupt event will also cause the corresponding INT\_CHn bit (INTCH1~3) to be set '1'.

An interrupt event is cleared by writing '1' to the corresponding Interrupt Status bit. The INT\_CHn bit (INTCH1~3) will not be cleared until all the interrupts in the corresponding channel are acknowledged. The  $\overline{INT}$  pin will be inactive until all the interrupts are acknowledged. Refer to Figure-29 for interrupt service flow.

**Table-15 Interrupt Summary**

No.	Interrupt Source	Status Bit	Interrupt Trigger Edges Select Bit	Interrupt Status Bit	Interrupt Mask Bit
1	TCLKn is missing.	TCKLOS_S (b3, STAT0,...)	TCKLOS_IES (b3, INTES,...)	TCKLOS_IS (b3, INTS0,...)	TCKLOS_IM (b3, INTM0,...)
2	LLOS is detected.	LLOS_S (b0, STAT0,...)	LOS_IES (b1, INTES,...)	LLOS_IS (b0, INTS0,...)	LLOS_IM (b0, INTM0,...)
3	SLOS is detected.	SLOS_S (b1, STAT0,...)	LOS_IES (b1, INTES,...)	SLOS_IS (b1, INTS0,...)	SLOS_IM (b1, INTM0,...)
4	TLOS is detected.	TLOS_S (b2, STAT0,...)	TLOS_IES (b2, INTES,...)	TLOS_IS (b2, INTS0,...)	TLOS_IM (b2, INTM0,...)
5	LAIS is detected.	LAIS_S (b6, STAT1,...)	AIS_IES (b6, INTES,...)	LAIS_IS (b6, INTS1,...)	LAIS_IM (b6, INTM1,...)
6	SAIS is detected.	SAIS_S (b7, STAT1,...)	AIS_IES (b6, INTES,...)	SAIS_IS (b7, INTS1,...)	SAIS_IM (b7, INTM1,...)
7	TOC is detected.	TOC_S (b4, STAT0,...)	TOC_IES (b4, INTES,...)	TOC_IS (b4, INTS0,...)	TOC_IM (b4, INTM0,...)
8	The PRBS/ARB pattern is detected synchronized.	PA_S (b5, STAT1,...)	PA_IES (b5, INTES,...)	PA_IS (b5, INTS1,...)	PA_IM (b5, INTM1,...)
9	Activate IB code is detected.	IBA_S (b1, STAT1,...)	IB_IES (b0, INTES,...)	IBA_IS (b1, INTS1,...)	IBA_IM (b1, INTM1,...)
10	Deactivate IB code is detected.	IBD_S (b0, STAT1,...)	IB_IES (b0, INTES,...)	IBD_IS (b0, INTS1,...)	IBD_IM (b0, INTM1,...)
11	The FIFO of the RJA is overflow or underflow.	-	-	RJA_IS (b5, INTS0,...)	RJA_IM (b5, INTM0,...)
12	The FIFO of the TJA is overflow or underflow.	-	-	TJA_IS (b6, INTS0,...)	TJA_IM (b6, INTM0,...)
13	Waveform amplitude is overflow.	-	-	DAC_IS (b7, INTS0,...)	DAC_IM (b7, INTM0,...)
14	SBPV is detected.	-	-	SBPV_IS (b5, INTS2,...)	SBPV_IM (b5, INTM2,...)
15	LBPV is detected.	-	-	LBPV_IS (b4, INTS2,...)	LBPV_IM (b4, INTM2,...)
16	SEXZ is detected.	-	-	SEXZ_IS (b3, INTS2,...)	SEXZ_IM (b3, INTM2,...)
17	LEXZ is detected.	-	-	LEXZ_IS (b2, INTS2,...)	LEXZ_IM (b2, INTM2,...)
18	PRBS/ARB error is detected.	-	-	ERR_IS (b1, INTS2,...)	ERR_IM (b1, INTM2,...)
19	The ERRCH and ERRCL registers are overflowed.	-	-	CNTOV_IS (b0, INTS2,...)	CNTOV_IM (b0, INTM2,...)
20	One second time is over.	-	-	TMOV_IS (b0, INTTM)	TMOV_IM (b0, GCF)

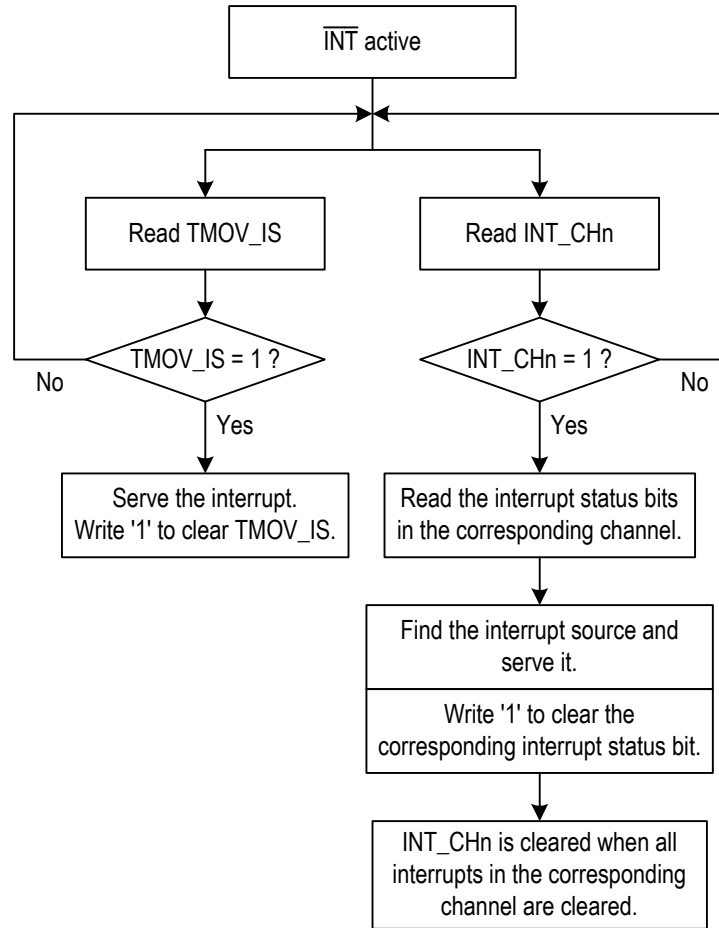


Figure-29 Interrupt Service Process



## 4 MISCELLANEOUS

### 4.1 RESET

The reset operation resets all registers, state machines as well as I/O pins to their default value or status.

The IDT82P20516 provides 4 kinds of reset:

- Power-on reset;
- Hardware reset;
- Global software reset;
- Per-channel software reset.

The Power-on, Hardware and Global software reset operations reset all the common blocks (including clock generator/synthesizer and microprocessor interface) and channel-related parts. The Per-channel software reset operation resets the channel-related parts. Figure-30 shows a general overview of the reset options.

During reset, all the line interface pins (i.e., TTIPn/TRINGn and RTIPn/RRINGn) are in High-Z state.

After reset, all the items listed in Table-16 are true.

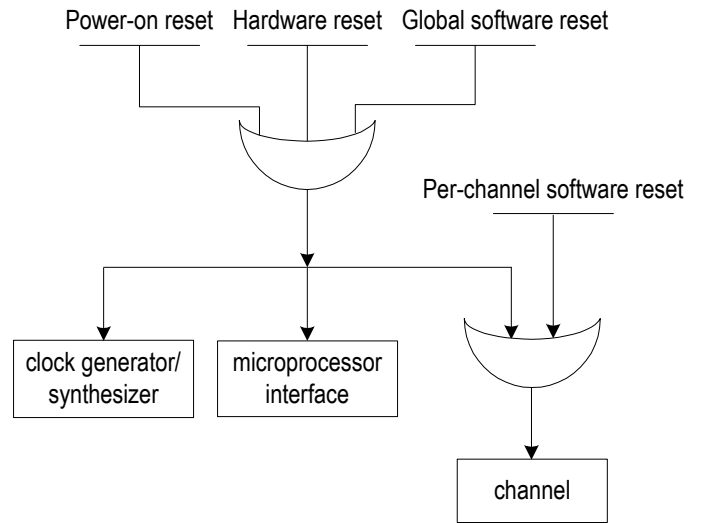


Figure-30 Reset

Table-16 After Reset Effect Summary

Effect On ...	Power-On Reset, Hardware Reset and Global Software Reset	Per-Channel Software Reset
TTIPn/TRINGn & RTIPn/RRINGn	All TTIPn/TRINGn & RTIPn/RRINGn pins are in High-Z state.	Only TTIPn/TRINGn & RTIPn/RRINGn in the corresponding channel are in High-Z.
System interface	All channels are in Dual Rail NRZ Format.	Only the corresponding channel is in Dual Rail NRZ Format.
General I/O pins (i.e., D[7:0] and GPIO[1:0])	As input pins.	(No effect)
$\overline{INT}$	Open drain output.	(No effect)
CLKE1	Output enable.	(No effect)
LLOS, LLOS0	Output enable.	(No effect)
TDO, SDO/ $\overline{ACK}$ /RDY	High-Z.	(No effect)
state machines	All state machines are reset.	The state machines in the corresponding channel are reset.
Interrupt sources	All interrupt sources are masked.	The interrupt sources in the corresponding channel are masked.
Registers	All registers are reset to their default value.	The registers in the corresponding channel are reset to their default value except that there is no effect on the E1 bit.

**4.1.1 POWER-ON RESET**

Power-on reset is initiated during power-up. When all VDD inputs (1.8V and 3.3V) reach approximately 60% of the standard value of VDD, power-on reset begins. If MCLK is applied, power-on reset will complete within 1 ms maximum; if MCLK is not applied, the device remains in reset state.

**4.1.2 HARDWARE RESET**

Pulling the  $\overline{RST}$  pin to low will initiate hardware reset. The reset cycle should be more than 1  $\mu$ s. If the  $\overline{RST}$  pin is held low continuously, the device remains in reset state.

**4.1.3 GLOBAL SOFTWARE RESET**

Writing the RST register will initiate global software reset. Once initiated, global software reset completes in 1  $\mu$ s maximum.

**4.1.4 PER-CHANNEL SOFTWARE RESET**

Writing a '1' to the CHRST bit (b1, CHCF,...) will initiate per-channel software reset. Once initiated, per-channel software reset completes in 1  $\mu$ s maximum and the CHRST bit (b1, CHCF,...) is self cleared.

This reset is different from other resets, for:

- It does not reset the E1 bit (b0, CHCF,...). That is, the operation mode of each channel is not changed;
- It does not reset the global registers, state machines and common pins (including the pins of clock generator, microprocessor interface and JTAG interface);
- It does not reset the other channels.

**4.2 MICROPROCESSOR INTERFACE**

The microprocessor interface provides access to read and write the registers in the device. The interface consists of:

- Serial microprocessor interface;

### 4.3 POWER UP

No power up sequencing for the VDD inputs (1.8 V and 3.3 V) has to be provided for the IDT82P20516. A Power-on reset will be initiated during power up. Refer to Section 4.1 Reset.

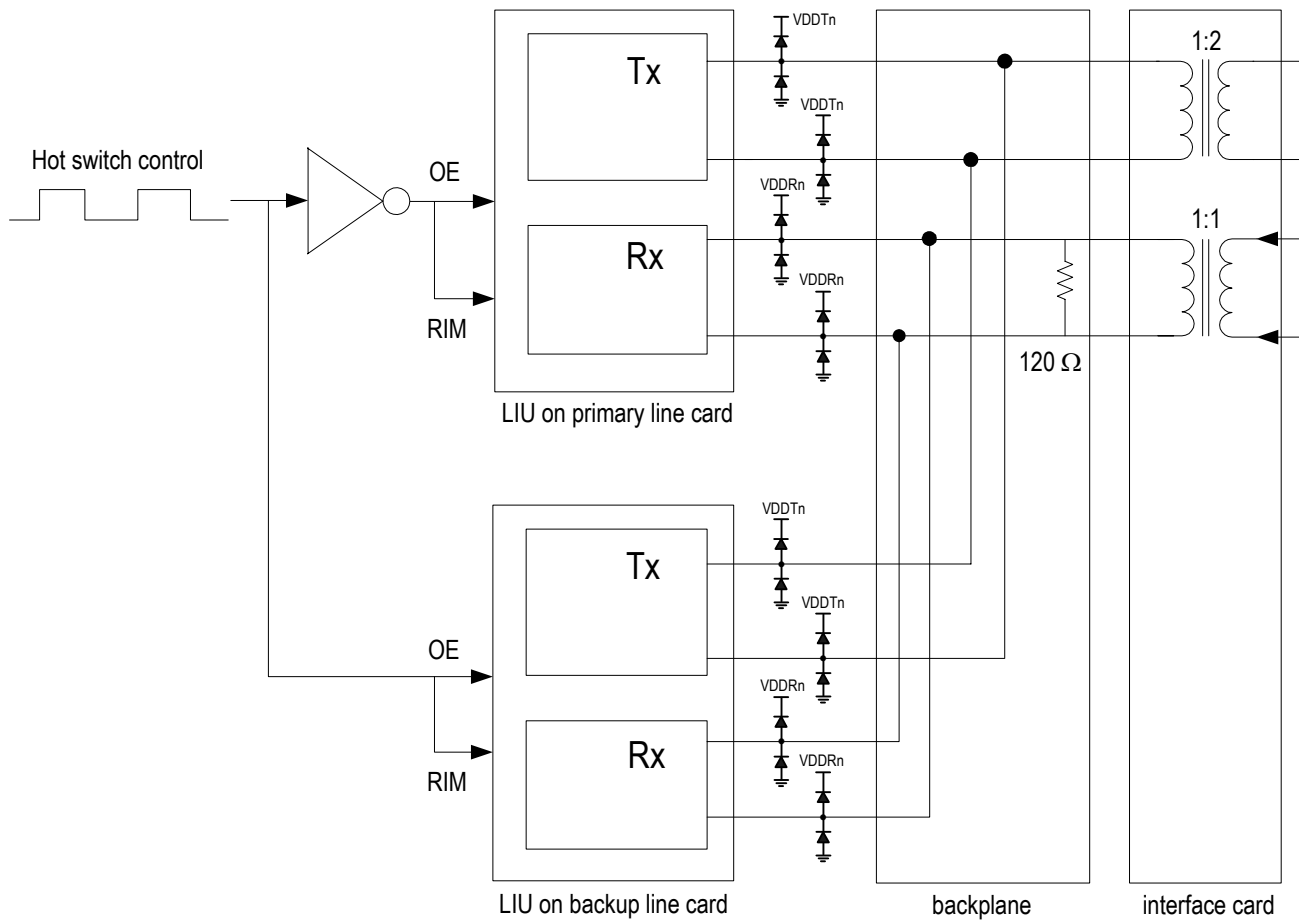
### 4.4 HITLESS PROTECTION SWITCHING (HPS) SUMMARY

In today's telecommunication systems, ensuring no traffic loss is becoming increasingly important. To combat these problems, redundancy protection must be built into the systems carrying this traffic. There are many types of redundancy protection schemes, including 1+1 and 1:1 hardware protection without the use of external relays. Refer to

Figure-31, Figure-32 and Figure-33 for different protection schemes. The IDT82P20516 provides an enhanced architecture to support both protection schemes.

IDT82P20516 highlights for HPS support:

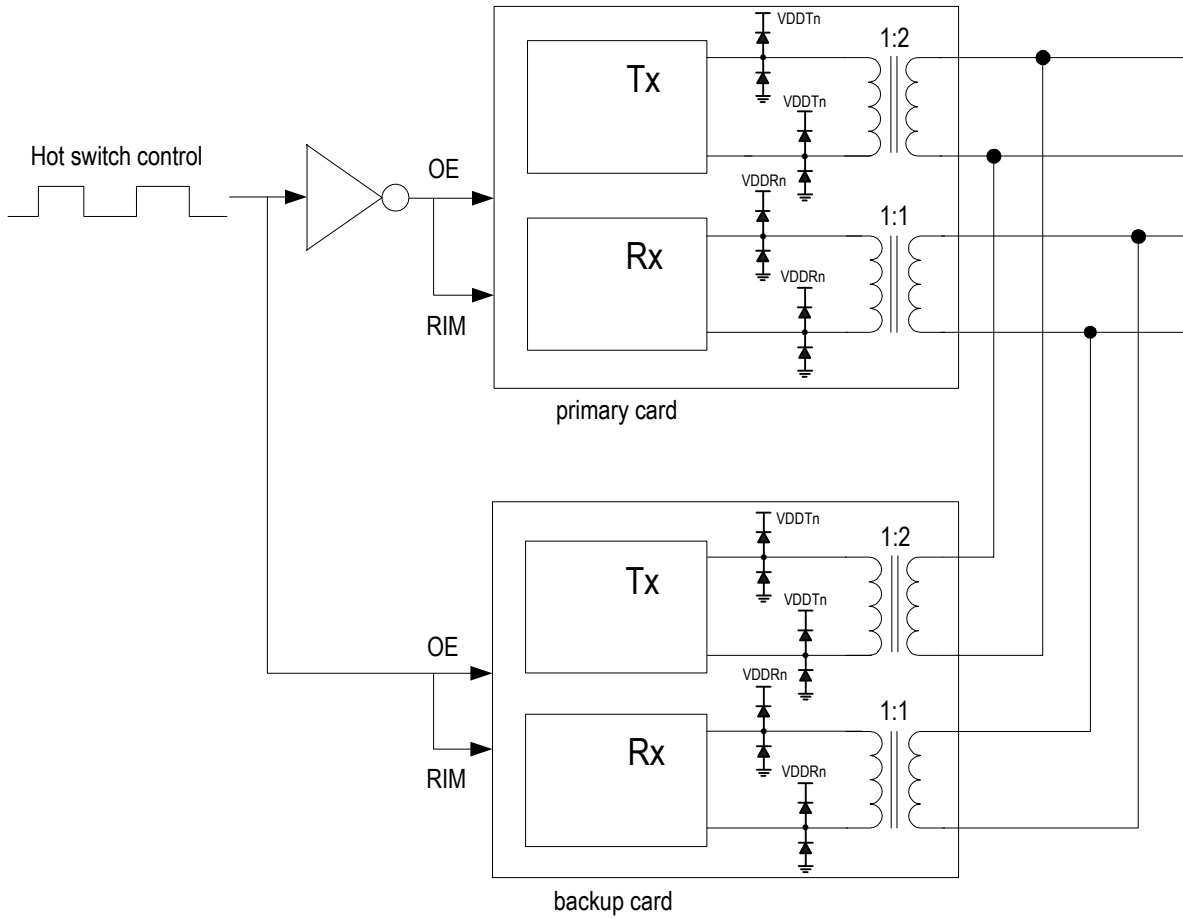
- Independent programmable receive and transmit high impedance for Tip and Ring inputs and outputs to support 1+1 and 1:1 redundancy
- Fully integrated receive termination, required to support 1:1 redundancy
- Enhanced internal architecture to guarantee High Impedance for Tip and Ring Inputs and Outputs during Power Off or Power Failure
- Asynchronous hardware control (OE, RIM) for fast global high impedance of receiver and transmitter (hot switching between working and backup board)



**Rx:** Partially Internal Impedance Matching mode. A fixed external 120 Ω resistor is placed on the backplane and provides a common termination for E1 applications. The R\_TERM[2:0] bits (b2~0, RCF0,...) setting is as follows: '010' for E1 120 Ω twisted pair cable and '011' for E1 75 Ω coaxial cable.

**Tx:** Internal Impedance Matching mode. The T\_TERM[2:0] bits (b2~0, TCF0,...) setting is as follows: '010' for E1 120 Ω twisted pair cable and '011' for E1 75 Ω coaxial cable.

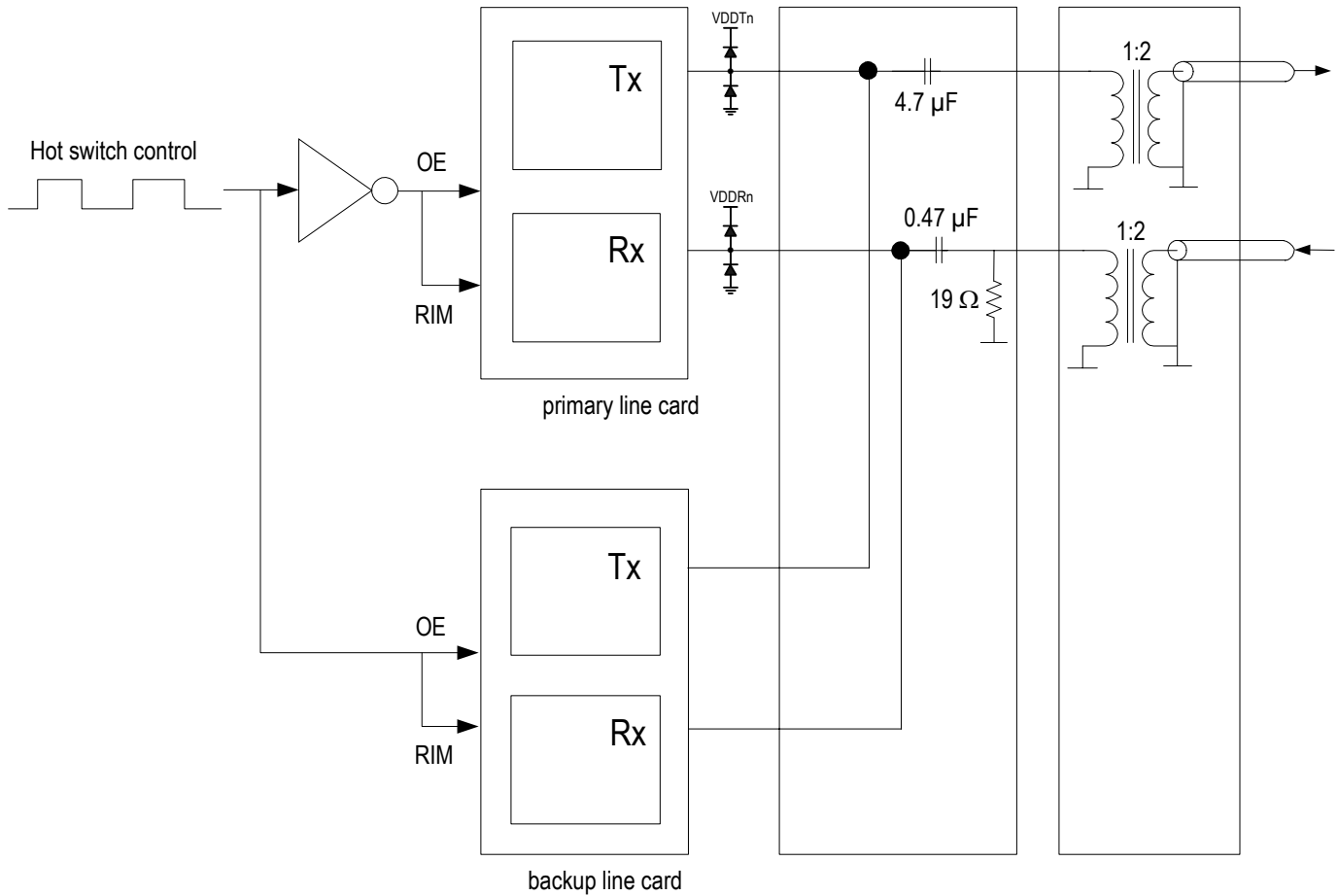
**Figure-31 1+1 HPS Scheme, Differential Interface (Shared Common Transformer)**



**Rx:** Fully Internal Impedance Matching mode. In this mode, there is no external resistor required. The R\_TERM[2:0] bits (b2~0, RCF0,...) setting is as follows: '010' for E1 120 Ω twisted pair cable and '011' for E1 75 Ω coaxial cable.

**Tx:** Internal Impedance Matching mode. The T\_TERM[2:0] bits (b2~0, TCF0,...) setting is as follows: '010' for E1 120 Ω twisted pair cable and '011' for E1 75 Ω coaxial cable.

**Figure-32 1:1 HPS Scheme, Differential Interface (Individual Transformer)**



**Rx:** 75 Ω External Impedance Matching mode. In this mode, there is no external resistor required. The RIM pin should be left open and the configuration of the R\_TERM[2:0] bits (b2~0, RCF0,...) is ignored.  
**Tx:** 75 Ω Internal Impedance Matching mode. The T\_TERM[2:0] bits (b2~0, TCF0,...) should be set to '011'.

**Figure-33 1+1 HPS Scheme, E1 75 ohm Single-Ended Interface (Shared Common Transformer)**

## 5 PROGRAMMING INFORMATION

### 5.1 REGISTER MAP

#### 5.1.1 GLOBAL REGISTER

Address (Hex)	Register Name	Bit 7	Bit 6	Bit 5	Bit 4	Bit 3	Bit 2	Bit 1	Bit 0	Reference Page
<i>Common Control</i>										
000	ID - Device ID Register	ID7	ID6	ID5	ID4	ID3	ID2	ID1	ID0	P 58
040	RST - Global Reset Register	RST7	RST6	RST5	RST4	RST3	RST2	RST1	RST0	P 58
080	GCF - Global Configuration Register	-	-	-	COPY	INT_PIN1	INT_PIN0	GLB_IM	TMOV_IM	P 59
0C0	MON - G.772 Monitor Configuration Register	-	-	MON5	MON4	MON3	MON2	MON1	MON0	P 59
100	GPIO - General Purpose I/O Pin Definition Register	-	-	-	-	LEVEL1	LEVEL0	DIR1	DIR0	P 60
<i>Reference Clock Timing Option</i>										
1C0	CLKG - CLKE1 Generation Control Register	-	-	-	-	CLKE1_EN	CLKE1	-	-	P 60
<i>Interrupt Indication</i>										
2C0	INTCH1 - Interrupt Requisition Source Register 1	INT_CH8	INT_CH7	INT_CH6	INT_CH5	INT_CH4	INT_CH3	INT_CH2	INT_CH1	P 61
300	INTCH2 - Interrupt Requisition Source Register 2	-	INT_CH15	INT_CH14	INT_CH13	INT_CH12	INT_CH11	INT_CH10	INT_CH9	P 61
380	INTCH3 - Interrupt Requisition Source Register 3	INT_CH0	-	-	-	-	-	-	-	P 61
3C0	INTTM - One Second Timer Interrupt Status Register	-	-	-	-	-	-	-	TMOV_IS	P 62

5.1.2 PER-CHANNEL REGISTER

Only the address of channel 1 is listed in the 'Address (Hex)' column of the following table. For the addresses of the other channels, refer to the description of each register.

Address (Hex)	Register Name	Bit 7	Bit 6	Bit 5	Bit 4	Bit 3	Bit 2	Bit 1	Bit 0	Reference Page
<i>Channel Control</i>										
001	CHCF - Channel Configuration Register	-	-	-	-	-	-	CHRST	E1	P 62
<i>JA Configuration</i>										
002	TJA - Transmit Jitter Attenuation Configuration Register	-	-	-	TJA_LIMT	TJA_EN	TJA_DP1	TJA_DP0	TJA_BW	P 63
003	RJA - Receive Jitter Attenuation Configuration Register	-	-	-	RJA_LIMT	RJA_EN	RJA_DP1	RJA_DP0	RJA_BW	P 64
<i>Transmit Path Configuration</i>										
004	TCF0 - Transmit Configuration Register 0	-	OE	T_OFF	THZ_OC	T_SING	T_TERM2	T_TERM1	T_TERM0	P 65
005	TCF1 - Transmit Configuration Register 1	-	-	-	TCK_ES	TD_INV	T_CODE	T_MD1	T_MD0	P 66
006	PULS - Transmit Pulse Configuration Register	-	-	-	-	PULS3	PULS2	PULS1	PULS0	P 67
007	SCAL - Amplitude Scaling Control Register	-	-	SCAL5	SCAL4	SCAL3	SCAL2	SCAL1	SCAL0	P 67
008	AWG0 - Arbitrary Waveform Generation Control Register 0	-	DONE	RW	SAMP4	SAMP3	SAMP2	SAMP1	SAMP0	P 68
009	AWG1 - Arbitrary Waveform Generation Control Register 1	-	WDAT6	WDAT5	WDAT4	WDAT3	WDAT2	WDAT1	WDAT0	P 68
<i>Receive Path Configuration</i>										
00A	RCF0 - Receive Configuration Register 0	RCKH	RHZ	R_OFF	R120IN	R_SING	R_TERM2	R_TERM1	R_TERM0	P 69
00B	RCF1 - Receive Configuration Register 1	-	-	-	RCK_ES	RD_INV	R_CODE	R_MD1	R_MD0	P 70
00C	RCF2 - Receive Configuration Register 2	-	-	-	-	-	-	MG1	MG0	P 70
<i>Diagnostics</i>										
00D	LOS - LOS Configuration Register	LAC	ALOS2	ALOS1	ALOS0	TALOS1	TALOS0	TDLOS1	TDLOS0	P 71
00E	ERR - Error Detection & Insertion Control Register	EXZ_DEF	BPV_INS	ERR_INS	CNT_SEL2	CNT_SEL1	CNT_SEL0	CNT_MD	CNT_STOP	P 72
00F	AISG - AIS Generation Control Register	-	-	-	TXAIS	AS AIS_SL OS	AS AIS_LLO S	AL AIS_SLO S	AL AIS_LLO S	P 73
010	PG - Pattern Generation Control Register	-	PG_CK	PG_EN1	PG_EN0	PG_POS	PAG_INV	PRBG_SEL 1	PRBG_SEL 0	P 74

Address (Hex)	Register Name	Bit 7	Bit 6	Bit 5	Bit 4	Bit 3	Bit 2	Bit 1	Bit 0	Reference Page
011	PD - Pattern Detection Control Register	-	-	-	-	PD_POS	PAD_INV	PAD_SEL1	PAD_SEL0	P 75
012	ARBL - Arbitrary Pattern Generation / Detection Low-Byte Register	ARB7	ARB6	ARB5	ARB4	ARB3	ARB2	ARB1	ARB0	P 76
013	ARBM - Arbitrary Pattern Generation / Detection Middle-Byte Register	ARB15	ARB14	ARB13	ARB12	ARB11	ARB10	ARB9	ARB8	P 76
014	ARBH - Arbitrary Pattern Generation / Detection High-Byte Register	ARB23	ARB22	ARB21	ARB20	ARB19	ARB18	ARB17	ARB16	P 76
015	IBL - Inband Loopback Control Register	-	-	IBGL1	IBGL0	IBAL1	IBAL0	IBDL1	IBDL0	P 77
016	IBG - Inband Loopback Generation Code Definition Register	IBG7	IBG6	IBG5	IBG4	IBG3	IBG2	IBG1	IBG0	P 77
017	IBDA - Inband Loopback Detection Target Activate Code Definition Register	IBA7	IBA6	IBA5	IBA4	IBA3	IBA2	IBA1	IBA0	P 78
018	IBDD - Inband Loopback Detection Target Deactivate Code Definition Register	IBD7	IBD6	IBD5	IBD4	IBD3	IBD2	IBD1	IBD0	P 78
019	LOOP - Loopback Control Register	-	-	-	-	AUTOLP	DLP	RLP	ALP	P 79
<i>Interrupt Edge Selection</i>										
01A	INTES - Interrupt Trigger Edges Select Register	-	AIS_IES	PA_IES	TOC_IES	TCKLOS_IES	TLOS_IES	LOS_IES	IB_IES	P 80
<i>Interrupt Mask</i>										
01B	INTM0 - Interrupt Mask Register 0	DAC_IM	TJA_IM	RJA_IM	TOC_IM	TCKLOS_IM	TLOS_IM	SLOS_IM	LLOS_IM	P 81
01C	INTM1 - Interrupt Mask Register 1	SAIS_IM	LAIS_IM	PA_IM	-	-	-	IBA_IM	IBD_IM	P 82
01D	INTM2 - Interrupt Mask Register 2	-	-	SBPV_IM	LBPV_IM	SEXZ_IM	LEXZ_IM	ERR_IM	CNTOV_IM	P 83
<i>Status Indication</i>										
01E	STAT0 - Status Register 0	AUTOLP_S	-	-	TOC_S	TCKLOS_S	TLOS_S	SLOS_S	LLOS_S	P 84
01F	STAT1 - Status Register 1	SAIS_S	LAIS_S	PA_S	-	-	-	IBA_S	IBD_S	P 85
<i>Interrupt Status Indication</i>										
020	INTS0 - Interrupt Status Register 0	DAC_IS	TJA_IS	RJA_IS	TOC_IS	TCKLOS_IS	TLOS_IS	SLOS_IS	LLOS_IS	P 86
021	INTS1 - Interrupt Status Register 1	SAIS_IS	LAIS_IS	PA_IS	-	-	-	IBA_IS	IBD_IS	P 87
022	INTS2 - Interrupt Status Register 2	-	-	SBPV_IS	LBPV_IS	SEXZ_IS	LEXZ_IS	ERR_IS	CNTOV_IS	P 88



Address (Hex)	Register Name	Bit 7	Bit 6	Bit 5	Bit 4	Bit 3	Bit 2	Bit 1	Bit 0	Reference Page
<i>Counter</i>										
023	ERRCL - Error Counter Low-Byte Register	ERRC7	ERRC6	ERRC5	ERRC4	ERRC3	ERRC2	ERRC1	ERRC0	P 89
024	ERRCH - Error Counter High-Byte Register	ERRC15	ERRC14	ERRC13	ERRC12	ERRC11	ERRC10	ERRC9	ERRC8	P 89
<i>Jitter Measurement (channel 0 Only)</i>										
7E5	JM - Jitter Measurement Configuration For Channel 0 Register	-	-	-	-	-	JM_STOP	JM_MD	JM_BW	P 90
7E6	JIT_PL - Positive Peak Jitter Measurement Low-Byte Register	JIT_P7	JIT_P6	JIT_P5	JIT_P4	JIT_P3	JIT_P2	JIT_P1	JIT_P0	P 90
7E7	JIT_PH - Positive Peak Jitter Measurement High-Byte Register	-	-	-	-	JIT_P11	JIT_P10	JIT_P9	JIT_P8	P 90
7E8	JIT_NL - Negative Peak Jitter Measurement Low-Byte Register	JIT_N7	JIT_N6	JIT_N5	JIT_N4	JIT_N3	JIT_N2	JIT_N1	JIT_N0	P 91
7E9	JIT_NH - Negative Peak Jitter Measurement High-Byte Register	-	-	-	-	JIT_N11	JIT_N10	JIT_N9	JIT_N8	P 91

## 5.2 REGISTER DESCRIPTION

### 5.2.1 GLOBAL REGISTER

#### ID - Device ID Register

Address: 000H							
Type: Read							
Default Value: 7xH							
7	6	5	4	3	2	1	0
ID7	ID6	ID5	ID4	ID3	ID2	ID1	ID0
Bit	Name	Description					
7 - 0	ID[7:0]	The ID[7:0] bits are pre-set, where the ID[3:0] bits 'x' represent the current version number ('0000' is for the first version).					

#### RST - Global Reset Register

Address: 040H							
Type: Write							
Default Value: 00H							
7	6	5	4	3	2	1	0
RST7	RST6	RST5	RST4	RST3	RST2	RST1	RST0
Bit	Name	Description					
7 - 0	RST[7:0]	Writing this register will initiate global software reset. This reset completes in 1 $\mu$ s maximum.					

**GCF - Global Configuration Register**

Address: 080H Type: Read / Write Default Value: 03H							
7	6	5	4	3	2	1	0
-	-	-	COPY	INT_PIN1	INT_PIN0	GLB_IM	TMOV_IM
Bit	Name	Description					
7 - 5	-	Reserved.					
4	COPY	When the per-channel register of one channel is written, this bit determines whether the written value is copied to the same register of the other channels simultaneously. 0: Disable. (default) 1: Enable.					
3 - 2	INT_PIN[1:0]	These two bits control the output on the INT pin. X0: Open drain, active low. (default) 01: Push-pull, active low. 11: Push-pull, active high.					
1	GLB_IM	This bit is a global configuration interrupt mask bit. 0: The per-channel interrupt will be generated when the per-channel interrupt mask bit is '0' and the corresponding interrupt status bit is '1'. 1: Mask all the per-channel interrupts. None per-channel interrupts can be generated. (default)					
0	TMOV_IM	This bit controls whether the interrupt is generated when one second time is over. This one second timer is locked to MCLK. 0: Enable. 1: Mask. (default)					

**MON - G.772 Monitor Configuration Register**

Address: 0C0H Type: Read / Write Default Value: 00H							
7	6	5	4	3	2	1	0
-	-	MON5	MON4	MON3	MON2	MON1	MON0
Bit	Name	Description					
7 - 6	-	Reserved.					
5 - 0	MON[5:0]	These bits determine whether the G.772 Monitor is implemented. When the G.772 Monitor is implemented, these bits select one transmitter or receiver to be monitored by channel 0. 000000: No transmitter or receiver is monitored. (default) 000001: The receiver of channel 1 is monitored. 000010: The receiver of channel 2 is monitored. ..... 001111: The receiver of channel 15 is monitored. 010000: The receiver of channel 16 is monitored. 010001 ~ 011111: Reserved. 100000: No transmitter or receiver is monitored. 100001: The transmitter of channel 1 is monitored. 100010: The transmitter of channel 2 is monitored. ..... 101111: The transmitter of channel 15 is monitored. 110000 ~ 111111: Reserved.					

**GPIO - General Purpose I/O Pin Definition Register**

Address: 100H  
 Type: Read / Write  
 Default Value: 0FH

7	6	5	4	3	2	1	0
-	-	-	-	LEVEL1	LEVEL0	DIR1	DIR0

Bit	Name	Description
7 - 4	-	Reserved.
3	LEVEL1	When the GPIO1 pin is defined as output, this bit determines the output level on GPIO1 and can be read and written. 0: Output low level. 1: Output high level. (default) When the GPIO1 pin is defined as input, this bit indicates the input level on GPIO1 and can only be read. 0: Input low level. 1: Input high level. (default)
2	LEVEL0	When the GPIO0 pin is defined as output, this bit determines the output level on GPIO0 and can be read and written. 0: Output low level. 1: Output high level. When the GPIO0 pin is defined as input, this bit indicates the input level on GPIO0 and can only be read. 0: Input low level. 1: Input high level. (default)
1	DIR1	This bit determines whether the GPIO1 pin is used as output or input. 0: Output. 1: Input. (default)
0	DIR0	This bit determines whether the GPIO0 pin is used as output or input. 0: Output. 1: Input. (default)

**CLKG - CLKE1 Generation Control Register**

Address: 1C0H  
 Type: Read / Write  
 Default Value: 0FH

7	6	5	4	3	2	1	0
-	-	-	-	CLKE1_EN	CLKE1	-	-

Bit	Name	Description
7 - 4	-	Reserved.
3	CLKE1_EN	This bit controls whether the output on the CLKE1 pin is enabled. 0: The output is disabled. CLKE1 is in High-Z state. 1: The output is enabled. The frequency of CLKE1 is determined by the CLKE1 bit (b2, CLKG). (default)
2	CLKE1	This bit is valid only when the CLKE1_EN bit (b3, CLKG) is '1'. This bit selects the clock frequency output on the CLKE1 pin. 0: 8 KHz. 1: 2.048 MHz. (default)
1	-	Reserved.
0	-	Reserved.

**INTCH1 - Interrupt Requisition Source Register 1**

Address: 2C0H Type: Read Default Value: 00H							
7	6	5	4	3	2	1	0
INT_CH8	INT_CH7	INT_CH6	INT_CH5	INT_CH4	INT_CH3	INT_CH2	INT_CH1
Bit	Name	Description					
7 - 0	INT_CH[8:1]	These bits indicate whether there is an interrupt generated in the corresponding channel. The INT_CH[8:1] bits correspond to channel 8 to 1 respectively. 0: No interrupt is generated or all the interrupts are cleared in the corresponding channel. (default) 1: At least one interrupt is generated in the corresponding channel.					

**INTCH2 - Interrupt Requisition Source Register 2**

Address: 300H Type: Read Default Value: 00H							
7	6	5	4	3	2	1	0
-	INT_CH15	INT_CH14	INT_CH13	INT_CH12	INT_CH11	INT_CH10	INT_CH9
Bit	Name	Description					
7	-	Reserved.					
6 - 0	INT_CH[15:9]	These bits indicate whether there is an interrupt generated in the corresponding channel. The INT_CH[16:9] bits correspond to channel 16 to 9 respectively. 0: No interrupt is generated or all the interrupts are cleared in the corresponding channel. (default) 1: At least one interrupt is generated in the corresponding channel.					

**INTCH3 - Interrupt Requisition Source Register 3**

Address: 380H Type: Read Default Value: 00H							
7	6	5	4	3	2	1	0
INT_CH0	-	-	-	-	-	-	-
Bit	Name	Description					
7	INT_CH0	This bit indicates whether there is an interrupt generated in channel 0. 0: No interrupt is generated or all the interrupts are cleared in channel 0. (default) 1: At least one interrupt is generated in channel 0.					
6 - 0	-	Reserved.					

**INTTM - One Second Timer Interrupt Status Register**

Address: 3C0H							
Type: Read / Write							
Default Value: 00H							
7	6	5	4	3	2	1	0
-	-	-	-	-	-	-	TMOV_IS
Bit	Name	Description					
7 - 1	-	Reserved.					
0	TMOV_IS	This bit is valid only when the TMOV_IM bit (b0, GCF) is '0'. This bit indicates the interrupt status of one second time over. 0: No one second time over interrupt is generated; or a '1' is written to this bit. (default) 1: One second time over interrupt is generated and is reported by the $\overline{\text{INT}}$ pin.					

**5.2.2 PER-CHANNEL REGISTER**

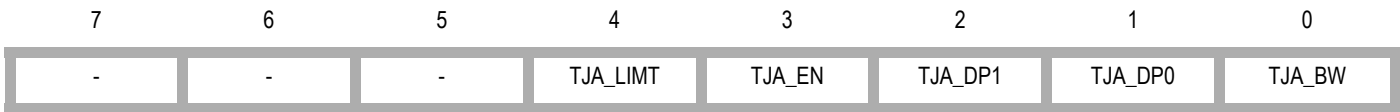
**CHCF - Channel Configuration Register**

Address: 001H, 041H, 081H, 0C1H, 101H, 141H, 181H, 1C1H, (CH1~CH8)							
201H, 241H, 281H, 2C1H, 301H, 341H, 381H, (CH9~CH15)							
7C1H (CH0)							
Type: Read / Write							
Default Value: 00H							
7	6	5	4	3	2	1	0
-	-	-	-	-	-	CHRST	E1
Bit	Name	Description					
7 - 2	-	Reserved.					
1	CHRST	Writing a '1' to this bit will initiate per-channel software reset. Once initiated, per-channel software reset completes in 1 $\mu$ s maximum. This bit is self cleared.					
0	E1	This bit is valid only when the TEHWE pin is low. This bit selects E1 operation mode. 1: E1. This bit can not be reset by per-channel software reset.					

**TJA - Transmit Jitter Attenuation Configuration Register**

Address: 002H, 042H, 082H, 0C2H, 102H, 142H, 182H, 1C2H, (CH1~CH8)  
 202H, 242H, 282H, 2C2H, 302H, 342H, 382H, (CH9~CH15)  
 7C2H (CH0)

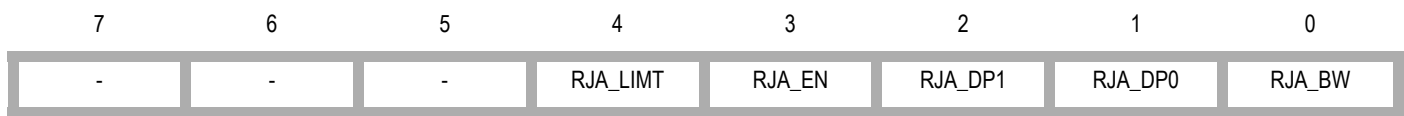
Type: Read / Write  
 Default Value: 00H



Bit	Name	Description
7 - 5	-	Reserved.
4	TJA_LIMT	This bit determines whether the JA-Limit function is enabled in the TJA. 0: Disable. (default) 1: Enable. The speed of the TJA outgoing data will be adjusted automatically if the FIFO in the TJA is 2-bit close to its full or emptiness.
3	TJA_EN	This bit controls whether the TJA is enabled to use. 0: Disable. (default) 1: Enable.
2 - 1	TJA_DP[1:0]	These bits select the depth of the TJA FIFO. 00: 128-bit. (default) 01: 64-bit. 1X: 32-bit.
0	TJA_BW	This bit selects the Corner Frequency for the TJA. 0: 6.77 Hz (in E1 mode). (default) 1: 0.87 Hz (in E1 mode).

**RJA - Receive Jitter Attenuation Configuration Register**

Address: 003H, 043H, 083H, 0C3H, 103H, 143H, 183H, 1C3H, (CH1~CH8)  
 203H, 243H, 283H, 2C3H, 303H, 343H, 383H, (CH9~CH15)  
 7C3H (CH0)  
 Type: Read / Write  
 Default Value: 00H



Bit	Name	Description
7 - 5	-	Reserved.
4	RJA_LIMT	This bit determines whether the JA-Limit function is enabled in the RJA. 0: Disable. (default) 1: Enable. The speed of the RJA outgoing data will be adjusted automatically if the FIFO in the RJA is 2-bit close to its full or emptiness.
3	RJA_EN	This bit controls whether the RJA is enabled to use. 0: Disable. (default) 1: Enable.
2 - 1	RJA_DP[1:0]	These bits select the depth of the RJA FIFO. 00: 128-bit. (default) 01: 64-bit. 1X: 32-bit.
0	RJA_BW	This bit selects the Corner Frequency for the RJA. 0: 6.77 Hz (in E1 mode). (default) 1: 0.87 Hz (in E1 mode).



**TCF0 - Transmit Configuration Register 0**

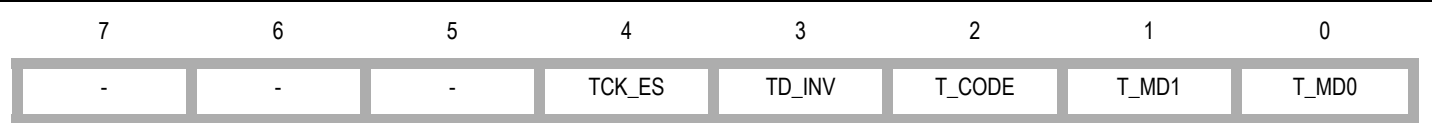
Address: 004H, 044H, 084H, 0C4H, 104H, 144H, 184H, 1C4H, (CH1~CH8) 204H, 244H, 284H, 2C4H, 304H, 344H, 384H, (CH9~CH15) 7C4H (CH0)							
Type: Read / Write Default Value: 00H							
7	6	5	4	3	2	1	0
-	OE	T_OFF	THZ_OC	T_SING	T_TERM2	T_TERM1	T_TERM0
Bit	Name	Description					
7	-	Reserved.					
6	OE	This bit determines the output of the Line Driver, i.e., the output on the TTIPn and TRINGn pins. 0: High-Z. (default) 1: Normal operation.					
5	T_OFF	This bit determines whether the transmitter is powered down. 0: Normal operation. (default) 1: Power down.					
4	THZ_OC	This bit determines the output of the Line Driver, i.e., the output on the TTIPn and TRINGn pins when TOC is detected. 0: The output current is limited to 100 mA <sub>p-p</sub> . (default) 1: The output current is limited to 100 mA <sub>p-p</sub> within the first 1 ms after the TOC is detected and then the output is in High-Z state when the TOC is detected for more than 1 ms.					
3	T_SING	This bit determines the transmit line interface. 0: Transmit Differential line interface. Both TTIPn and TRINGn are used to transmit signal to the line side. (default) 1: Transmit Single Ended line interface. Only TTIPn is used to transmit signal. TRINGn should be left open.					
2 - 0	T_TERM[2:0]	These bits select the impedance matching mode of the transmit path to match the cable impedance.  010: The 120 Ω internal impedance matching is selected for E1 120 Ω twisted pair cable (with transformer). 011: The 75 Ω internal impedance matching is selected for E1 75 Ω coaxial cable (with transformer). 110: The 120 Ω internal impedance matching is selected for E1 120 Ω twisted pair cable (transformer-less). 111: The external impedance matching is selected for E1 120 Ω twisted pair cable or E1 75 Ω coaxial cable (with transformer).					

**TCF1 - Transmit Configuration Register 1**

Address: 005H, 045H, 085H, 0C5H, 105H, 145H, 185H, 1C5H, (CH1~CH8)  
 205H, 245H, 285H, 2C5H, 305H, 345H, 385H, (CH9~CH15)  
 7C5H (CH0)

Type: Read / Write

Default Value: 01H



Bit	Name	Description
7 - 5	-	Reserved.
4	TCK_ES	This bit selects the active edge of the TCLKn pin. 0: Falling edge. (default) 1: Rising edge.
3	TD_INV	This bit determines the active level on the TDn, TDPn and TDNn pins. 0: Active high. (default) 1: Active low.
2	T_CODE	This bit selects the line code rule for the transmit path. 0: HDB3 (in E1 mode). (default) 1: AMI.
1 - 0	T_MD[1:0]	These bits determines the transmit system interface. 00: Transmit Single Rail NRZ Format system interface. The data is input on TDn in NRZ format and a 2.048 MHz (in E1 mode) clock is input on TCLKn. 01: Transmit Dual Rail NRZ Format system interface. The data is input on TDPn and TDNn in NRZ format and a 2.048 MHz (in E1 mode) clock is input on TCLKn. (default) 10: Transmit Dual Rail RZ Format system interface. The data is input on TDPn and TDNn in RZ format. 11: Reserved.

**PULS - Transmit Pulse Configuration Register**

Address: 006H, 046H, 086H, 0C6H, 106H, 146H, 186H, 1C6H, (CH1~CH8)  
 206H, 246H, 286H, 2C6H, 306H, 346H, 386H, (CH9~CH15)  
 7C6H (CH0)

Type: Read / Write  
 Default Value: 02H

7	6	5	4	3	2	1	0
-	-	-	-	PULS3	PULS2	PULS1	PULS0

Bit	Name	Description																																																												
7 - 4	-	Reserved.																																																												
3 - 0	PULS[3:0]	These bits select one of the eight preset waveform templates for short haul application or enable user-programmable arbitrary waveform. <table border="1" style="width: 100%; margin-top: 10px;"> <thead> <tr> <th>PULS[3:0]</th> <th>Operation Mode</th> <th>Transmit Clock</th> <th>Cable Impedance</th> <th>Cable Range</th> <th>Cable Loss</th> </tr> </thead> <tbody> <tr> <td>0000</td> <td>E1</td> <td>2.048 MHz</td> <td>E1 75 Ω</td> <td>-</td> <td>0 ~ 12 dB</td> </tr> <tr> <td>0001</td> <td>E1</td> <td>2.048 MHz</td> <td>E1 120 Ω</td> <td>-</td> <td>0 ~ 12 dB</td> </tr> <tr> <td>0010 (default)</td> <td>DSX1</td> <td>1.544 MHz</td> <td>100 Ω</td> <td>0 ~ 133 ft</td> <td>0 ~ 0.6 dB</td> </tr> <tr> <td>0011</td> <td>DSX1</td> <td>1.544 MHz</td> <td>100 Ω</td> <td>133 ~ 266 ft</td> <td>0.6 ~ 1.2 dB</td> </tr> <tr> <td>0100</td> <td>DSX1</td> <td>1.544 MHz</td> <td>100 Ω</td> <td>266 ~ 399 ft</td> <td>1.2 ~ 1.8 dB</td> </tr> <tr> <td>0101</td> <td>DSX1</td> <td>1.544 MHz</td> <td>100 Ω</td> <td>399 ~ 533 ft</td> <td>1.8 ~ 2.4 dB</td> </tr> <tr> <td>0110</td> <td>DSX1</td> <td>1.544 MHz</td> <td>100 Ω</td> <td>533 ~ 655 ft</td> <td>2.4 ~ 3.0 dB</td> </tr> <tr> <td>0111</td> <td>J1</td> <td>1.544 MHz</td> <td>110 Ω</td> <td>-</td> <td>0 ~ 12 dB</td> </tr> <tr> <td>1XXX</td> <td colspan="5" style="text-align: center;">User-programmable arbitrary waveform</td> </tr> </tbody> </table>	PULS[3:0]	Operation Mode	Transmit Clock	Cable Impedance	Cable Range	Cable Loss	0000	E1	2.048 MHz	E1 75 Ω	-	0 ~ 12 dB	0001	E1	2.048 MHz	E1 120 Ω	-	0 ~ 12 dB	0010 (default)	DSX1	1.544 MHz	100 Ω	0 ~ 133 ft	0 ~ 0.6 dB	0011	DSX1	1.544 MHz	100 Ω	133 ~ 266 ft	0.6 ~ 1.2 dB	0100	DSX1	1.544 MHz	100 Ω	266 ~ 399 ft	1.2 ~ 1.8 dB	0101	DSX1	1.544 MHz	100 Ω	399 ~ 533 ft	1.8 ~ 2.4 dB	0110	DSX1	1.544 MHz	100 Ω	533 ~ 655 ft	2.4 ~ 3.0 dB	0111	J1	1.544 MHz	110 Ω	-	0 ~ 12 dB	1XXX	User-programmable arbitrary waveform				
PULS[3:0]	Operation Mode	Transmit Clock	Cable Impedance	Cable Range	Cable Loss																																																									
0000	E1	2.048 MHz	E1 75 Ω	-	0 ~ 12 dB																																																									
0001	E1	2.048 MHz	E1 120 Ω	-	0 ~ 12 dB																																																									
0010 (default)	DSX1	1.544 MHz	100 Ω	0 ~ 133 ft	0 ~ 0.6 dB																																																									
0011	DSX1	1.544 MHz	100 Ω	133 ~ 266 ft	0.6 ~ 1.2 dB																																																									
0100	DSX1	1.544 MHz	100 Ω	266 ~ 399 ft	1.2 ~ 1.8 dB																																																									
0101	DSX1	1.544 MHz	100 Ω	399 ~ 533 ft	1.8 ~ 2.4 dB																																																									
0110	DSX1	1.544 MHz	100 Ω	533 ~ 655 ft	2.4 ~ 3.0 dB																																																									
0111	J1	1.544 MHz	110 Ω	-	0 ~ 12 dB																																																									
1XXX	User-programmable arbitrary waveform																																																													

**SCAL - Amplitude Scaling Control Register**

Address: 007H, 047H, 087H, 0C7H, 107H, 147H, 187H, 1C7H, (CH1~CH8)  
 207H, 247H, 287H, 2C7H, 307H, 347H, 387H, (CH9~CH15)  
 7C7H (CH0)

Type: Read / Write  
 Default Value: 36H

7	6	5	4	3	2	1	0
-	-	SCAL5	SCAL4	SCAL3	SCAL2	SCAL1	SCAL0

Bit	Name	Description
7 - 6	-	Reserved.
5 - 0	SCAL[5:0]	These bits specify a scaling factor to be applied to the amplitude of the waveform to be transmitted. In E1 mode, the standard value is '100001' for the waveform amplitude. If necessary, increasing or decreasing by '1' from the standard value will result in 3% scaling up or down against the waveform amplitude. The scale range is from +100% to -100%. <b>Note:</b> Therefore, if E1 mode is used, '100001' should be written to these bits to indicate the E1 standard value.

**AWG0 - Arbitrary Waveform Generation Control Register 0**

Address: 008H, 048H, 088H, 0C8H, 108H, 148H, 188H, 1C8H, (CH1~CH8)  
 208H, 248H, 288H, 2C8H, 308H, 348H, 388H, (CH9~CH15)  
 7C8H (CH0)  
 Type: Read / Write  
 Default Value: 00H

7	6	5	4	3	2	1	0
-	DONE	RW	SAMP4	SAMP3	SAMP2	SAMP1	SAMP0

Bit	Name	Description
7	-	Reserved.
6	DONE	This bit is valid only when the user-programmable arbitrary waveform is enabled (i.e., the PULS[3:0] bits (b3~0, PULS,...) are set to '1XXX'). This bit determines whether to enable the data writing/reading from RAM. 0: Disable. (default) 1: Enable.
5	RW	This bit is valid only when the user-programmable arbitrary waveform is enabled (i.e., the PULS[3:0] bits (b3~0, PULS,...) are set to '1XXX'). This bit determines read/write direction. 0: Write data to RAM. (default) 1: Read data from RAM.
4 - 0	SAMP[4:0]	These bits are valid only when the user-programmable arbitrary waveform is enabled (i.e., the PULS[3:0] bits (b3~0, PULS,...) are set to '1XXX'). These bits specify the RAM sample address. 00000: The RAM sample address is 0. (default) 00001: The RAM sample address is 1. 00010: The RAM sample address is 2. ..... 10001: The RAM sample address is 17. 10010: The RAM sample address is 18. 10011 ~ 11111: The RAM sample address is 19.

**AWG1 - Arbitrary Waveform Generation Control Register 1**

Address: 009H, 049H, 089H, 0C9H, 109H, 149H, 189H, 1C9H, (CH1~CH8)  
 209H, 249H, 289H, 2C9H, 309H, 349H, 389H, (CH9~CH15)  
 7C9H (CH0)  
 Type: Read / Write  
 Default Value: 00H

7	6	5	4	3	2	1	0
-	WDAT6	WDAT5	WDAT4	WDAT3	WDAT2	WDAT1	WDAT0

Bit	Name	Description
7	-	Reserved.
6 - 0	WDAT[6:0]	These bits are valid only when the user-programmable arbitrary waveform is enabled (i.e., the PULS[3:0] bits (b3~0, PULS,...) are set to '1XXX'). These bits contain the template sample data to be stored in RAM which address is specified by the SAMP[4:0] bits (b4~0, AWG0,...). They are not updated until new template sample data is written.

**RCF0 - Receive Configuration Register 0**

Address: 00AH, 04AH, 08AH, 0CAH, 10AH, 14AH, 18AH, 1CAH, (CH1~CH8) 20AH, 24AH, 28AH, 2CAH, 30AH, 34AH, 38AH, (CH9~CH15) 7CAH (CH0)							
Type: Read / Write Default Value: 47H							
7	6	5	4	3	2	1	0
RCKH	RHZ	R_OFF	R120IN	R_SING	R_TERM2	R_TERM1	R_TERM0
Bit	Name	Description					
7	RCKH	This bit determines the output on RCLKn when LLOS is detected. This bit is valid only when LLOS is detected and the AIS and pattern generation is disabled in the receive path. 0: XCLK. (default) 1: High level.					
6	RHZ	This bit determines the output of all receive system interfaced pins (including RDPn, RDNn and RCLKn) when the corresponding receiver is powered down. 0: Low level. 1: High-Z. (default)					
5	R_OFF	This bit determines whether the receiver is powered down. 0: Normal operation. (default) 1: Power down.					
4	R120IN	This bit is valid only when the receive line interface is in Receive Differential mode and per-channel internal impedance matching configuration is enabled. This bit selects the internal impedance matching mode. 0: Partially Internal Impedance Matching mode. An internal programmable resistor (IM) and a value-fixed external resistor (Rr) are used. (default) 1: Fully Internal Impedance Matching mode. Only an internal programmable resistor (IM) is used.					
3	R_SING	This bit determines the receive line interface. 0: Receive Differential line interface. Both RTIPn and RRINGn are used to receive signal from the line side. (default)					
2 - 0	R_TERM[2:0]	These bits are valid only when impedance matching is configured on a per-channel basis. These bits select the impedance matching mode of the receive path to match the cable impedance. In Receive Differential mode: 010: The 120 Ω internal impedance matching is selected for E1 120 Ω twisted pair cable. 011: The 75 Ω internal impedance matching is selected for E1 75 Ω coaxial cable. 1XX: External impedance matching is selected for E1 120 Ω twisted pair cable and E1 75 Ω coaxial cable. In Receive Single Ended mode, only External Impedance Matching is supported and the setting of these bits is a don't-care. (default)					

**RCF1 - Receive Configuration Register 1**

Address: 00BH, 04BH, 08BH, 0CBH, 10BH, 14BH, 18BH, 1CBH, (CH1~CH8) 20BH, 24BH, 28BH, 2CBH, 30BH, 34BH, 38BH, (CH9~CH15) 7CBH (CH0)							
Type: Read / Write Default Value: 01H							
7	6	5	4	3	2	1	0
-	-	-	RCK_ES	RD_INV	R_CODE	R_MD1	R_MD0
Bit	Name	Description					
7 - 5	-	Reserved.					
4	RCK_ES	This bit selects the active edge of the RCLKn pin. 0: Rising edge. (default) 1: Falling edge.					
3	RD_INV	This bit determines the active level on the RDPn and RDNn pins. 0: Active high. (default) 1: Active low.					
2	R_CODE	This bit selects the line code rule for the receive path. 0: HDB3 (in E1 mode). (default) 1: AMI.					
1 - 0	R_MD[1:0]	These bits determines the receive system interface. 01: Receive Dual Rail NRZ Format system interface. The data is output on RDPn and RDNn in NRZ format and a 2.048 MHz (in E1 mode) recovered clock is output on RCLKn. (default) 10: Receive Dual Rail RZ Format system interface. The data is output on RDPn and RDNn in RZ format and a 2.048 MHz (in E1 mode) recovered clock is output on RCLKn. 11: Receive Dual Rail Sliced system interface. The data is output on RDPn and RDNn in RZ format directly after passing through the Slicer.					

**RCF2 - Receive Configuration Register 2**

Address: 00CH, 04CH, 08CH, 0CCH, 10CH, 14CH, 18CH, 1CCH, (CH1~CH8) 20CH, 24CH, 28CH, 2CCH, 30CH, 34CH, 38CH, (CH9~CH15) 7CCH (CH0)							
Type: Read / Write Default Value: 00H							
7	6	5	4	3	2	1	0
-	-	-	-	-	-	MG1	MG0
Bit	Name	Description					
7 - 2	-	Reserved.					
1 - 0	MG[1:0]	These bits select the Monitor Gain. 00: 0 dB. (default) 01: 20 dB. 10: 26 dB. 11: 32 dB.					

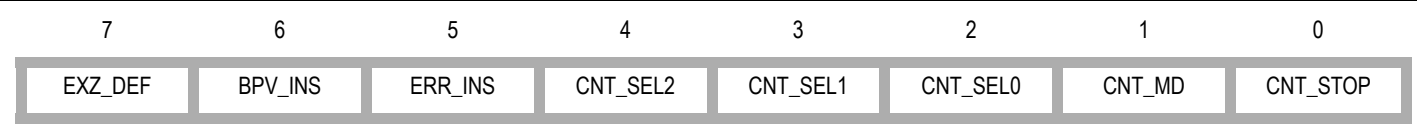
LOS - LOS Configuration Register

Address: 00DH, 04DH, 08DH, 0CDH, 10DH, 14DH, 18DH, 1CDH, (CH1~CH8) 20DH, 24DH, 28DH, 2CDH, 30DH, 34DH, 38DH, (CH9~CH15) 7CDH (CH0)																																																																			
Type: Read / Write Default Value: 15H																																																																			
7	6	5	4	3	2	1	0																																																												
LAC	ALOS2	ALOS1	ALOS0	TALOS1	TALOS0	TDLOS1	TDLOS0																																																												
Bit	Name	Description																																																																	
7	LAC	This bit selects the LLOS, SLOS and AIS criteria. 0: G.775 (in E1 mode). (default) 1: ETSI 300233 & I.431 (in E1 mode).																																																																	
6 - 4	ALOS[2:0]	These bits select the amplitude threshold (Q). When the amplitude of the data is less than Q Vpp for N consecutive pulse intervals, LLOS is declared. The consecutive pulse intervals (N) are determined by the LAC bit (b7, LOS,...). The ALOS[2:0] settings for Normal Receive mode and Line Monitor mode are different. Refer to below tables. <b>ALOS[2:0] Setting in Normal Receive Mode</b> <table border="1" style="margin-left: 40px;"> <thead> <tr> <th>ALOS[2:0]</th> <th>Q (Vpp)</th> <th>vs. 6.0 Vpp (dB)</th> <th>vs. 4.74 Vpp (dB)</th> </tr> </thead> <tbody> <tr><td>000</td><td>0.5</td><td>21.58</td><td>19.54</td></tr> <tr><td>001 (default)</td><td>0.7</td><td>18.66</td><td>16.61</td></tr> <tr><td>010</td><td>0.9</td><td>16.48</td><td>14.43</td></tr> <tr><td>011</td><td>1.2</td><td>13.98</td><td>11.93</td></tr> <tr><td>100</td><td>1.4</td><td>12.64</td><td>10.59</td></tr> <tr><td>101</td><td>1.6</td><td>11.48</td><td>9.43</td></tr> <tr><td>110</td><td>1.8</td><td>10.46</td><td>8.41</td></tr> <tr><td>111</td><td>2.0</td><td>9.54</td><td>7.49</td></tr> </tbody> </table> <b>ALOS[2:0] Setting in Line Monitor Mode</b> <table border="1" style="margin-left: 40px;"> <thead> <tr> <th>ALOS[2:0]</th> <th>Q (Vpp)</th> <th>vs. 6.0 Vpp (dB)</th> <th>vs. 4.74 Vpp (dB)</th> </tr> </thead> <tbody> <tr><td>000</td><td>1.0</td><td>15.56</td><td>13.52</td></tr> <tr><td>001 (default)</td><td>1.4</td><td>12.64</td><td>10.59</td></tr> <tr><td>010</td><td>1.8</td><td>10.46</td><td>8.41</td></tr> <tr><td>011</td><td>2.2</td><td>8.71</td><td>6.67</td></tr> <tr><td>1xx</td><td colspan="3" style="text-align: center;">reserved.</td></tr> </tbody> </table>						ALOS[2:0]	Q (Vpp)	vs. 6.0 Vpp (dB)	vs. 4.74 Vpp (dB)	000	0.5	21.58	19.54	001 (default)	0.7	18.66	16.61	010	0.9	16.48	14.43	011	1.2	13.98	11.93	100	1.4	12.64	10.59	101	1.6	11.48	9.43	110	1.8	10.46	8.41	111	2.0	9.54	7.49	ALOS[2:0]	Q (Vpp)	vs. 6.0 Vpp (dB)	vs. 4.74 Vpp (dB)	000	1.0	15.56	13.52	001 (default)	1.4	12.64	10.59	010	1.8	10.46	8.41	011	2.2	8.71	6.67	1xx	reserved.		
ALOS[2:0]	Q (Vpp)	vs. 6.0 Vpp (dB)	vs. 4.74 Vpp (dB)																																																																
000	0.5	21.58	19.54																																																																
001 (default)	0.7	18.66	16.61																																																																
010	0.9	16.48	14.43																																																																
011	1.2	13.98	11.93																																																																
100	1.4	12.64	10.59																																																																
101	1.6	11.48	9.43																																																																
110	1.8	10.46	8.41																																																																
111	2.0	9.54	7.49																																																																
ALOS[2:0]	Q (Vpp)	vs. 6.0 Vpp (dB)	vs. 4.74 Vpp (dB)																																																																
000	1.0	15.56	13.52																																																																
001 (default)	1.4	12.64	10.59																																																																
010	1.8	10.46	8.41																																																																
011	2.2	8.71	6.67																																																																
1xx	reserved.																																																																		
3 - 2	TALOS[1:0]	These bits select the amplitude threshold. When the amplitude of the data is less than the threshold for a certain period, TLOS is declared. The period is determined by the TDLOS bits (b1~0, LOS,...). When the amplitude of a pulse is above the threshold, TLOS is cleared. For Differential line interface: 00: 1.2 Vp. 01: 0.9 Vp. (default) 10: 0.6 Vp. 11: 0.4 Vp. For Single Ended line interface: 00: 0.61 Vp. 01: 0.48 Vp. (default) 10: 0.32 Vp. 11: 0.24 Vp.																																																																	

1 - 0	TDLOS[1:0]	These bits select the period. When the amplitude of the data is less than a certain voltage for the period, TLOS is declared. The voltage is determined by the TALOS bits (b3~2, LOS,...). 00: 16-pulse. 01: 32-pulse. (default) 1X: 64-pulse.
-------	------------	---

**ERR - Error Detection & Insertion Control Register**

Address: 00EH, 04EH, 08EH, 0CEH, 10EH, 14EH, 18EH, 1CEH, (CH1~CH8)  
20EH, 24EH, 28EH, 2CEH, 30EH, 34EH, 38EH, (CH9~CH15)  
7CEH (CH0)  
Type: Read / Write  
Default Value: 00H



Bit	Name	Description
7	EXZ_DEF	This bit selects the EXZ definition standard. 0: ANSI. (default) 1: FCC.
6	BPV_INS	This bit controls whether to insert a bipolar violation (BPV) to the transmit path. Writing '1' to this bit will insert a BPV on the next available mark in the data stream to be transmitted. This bit is cleared once the BPV insertion is completed.
5	ERR_INS	This bit controls whether to insert a single bit error to the generated PRBS/ARB pattern. A transition from '0' to '1' on this bit will insert a single bit error to the generated PRBS/ARB pattern. This bit is cleared once the single bit error insertion is completed.
4 - 2	CNT_SEL[2:0]	These bits select what kind of error to be counted by the internal Error Counter. 000: Disable. (default) 001: LBPV. 010: LEXZ. 011: LBPV + LEXZ. 100: SBPV. 101: SEXZ. 110: SBPV + SEXZ. 111: PRBS/ARB error.
1	CNT_MD	This bit determines whether the ERRCH & ERRCL registers are updated automatically or manually. 0: Manually by setting the CNT_STOP bit (b0, ERR,...). (default) 1: Every-one second automatically.
0	CNT_STOP	This bit is valid only when the CNT_MD bit (b1, ERR,...) is '0'. A transition from '0' to '1' on this bit updates the ERRCH & ERRCL registers. This bit must be cleared before the next round.



**AISG - AIS Generation Control Register**

Address: 00FH, 04FH, 08FH, 0CFH, 10FH, 14FH, 18FH, 1CFH, (CH1~CH8)  
 20FH, 24FH, 28FH, 2CFH, 30FH, 34FH, 38FH, (CH9~CH15)  
 7CFH (CH0)

Type: Read / Write  
 Default Value: 00H

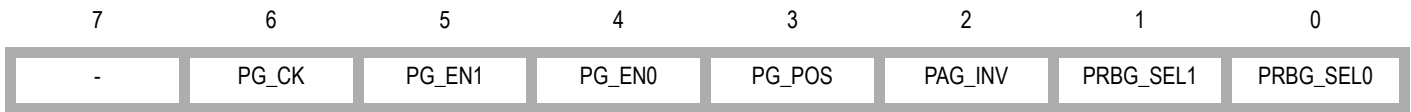


Bit	Name	Description
7 - 5	-	Reserved.
4	TXAIS	This bit controls the transmission of AIS in the transmit path. 0: Disable. (default) 1: Transmit all ones pattern at TTIPn/TRINGn. In remote loopback, this bit is ignored.
3	AS AIS_SLOS	This bit controls the AIS generation in the receive path once SLOS is detected. 0: Disable. (default) 1: Enable.
2	AS AIS_LLOS	This bit controls the AIS generation in the receive path once LLOS is detected. 0: Disable. (default) 1: Enable.
1	AL AIS_SLOS	This bit controls the AIS generation in the transmit path once SLOS is detected. 0: Disable. (default) 1: Enable.
0	AL AIS_LLOS	This bit controls the AIS generation in the transmit path once LLOS is detected. 0: Disable. (default) 1: Enable.

**PG - Pattern Generation Control Register**

Address: 010H, 050H, 090H, 0D0H, 110H, 150H, 190H, 1D0H, (CH1~CH8)  
 210H, 250H, 290H, 2D0H, 310H, 350H, 390H, (CH9~CH15)  
 7D0H (CH0)

Type: Read / Write  
 Default Value: 00H



Bit	Name	Description
7	-	Reserved.
6	PG_CK	This bit selects the reference clock when the pattern (including PRBS, ARB & IB) is generated. When the pattern is generated in the receive path: 0: XCLK. (default) 1: Recovered clock from the received signal. When the pattern is generated in the transmit path: 0: XCLK. (default) 1: Transmit clock, i.e., the clock input on TCLKn (in Transmit Single Rail NRZ Format mode and in Transmit Dual Rail NRZ Format mode) or the clock recovered from the data input on TDPn and TDNn (in Transmit Dual Rail RZ Format mode)
5 - 4	PG_EN[1:0]	These bits select the pattern to be generated. 00: Disable. (default) 01: PRBS. 10: ARB. 11: IB.
3	PG_POS	This bit selects the pattern (including PRBS, ARB & IB) generation direction. 0: Transmit path. (default) 1: Receive path.
2	PAG_INV	This bit controls whether to invert the generated PRBS/ARB pattern. 0: Normal. (default) 1: Invert.
1 - 0	PRBG_SEL[1:0]	These bits are valid only when the PRBS pattern is generated. They select the PRBS pattern. 00: $2^{20} - 1$ QRSS. (default) 01: $2^{15} - 1$ PRBS. 1X: $2^{11} - 1$ PRBS.

**PD - Pattern Detection Control Register**

Address: 011H, 051H, 091H, 0D1H, 111H, 151H, 191H, 1D1H, (CH1~CH8)  
 211H, 251H, 291H, 2D1H, 311H, 351H, 391H, (CH9~CH15)  
 7D1H (CH0)  
 Type: Read / Write  
 Default Value: 03H



Bit	Name	Description
7 - 4	-	Reserved.
3	PD_POS	This bit selects the pattern (including PRBS, ARB & IB) detection direction. 0: Receive path. (default) 1: Transmit path.
2	PAD_INV	This bit controls whether to invert the data before PRBS/ARB detection. 0: Normal. (default) 1: Invert.
1 - 0	PAD_SEL[1:0]	These bits select the desired PRBS/ARB pattern to be detected. 00: $2^{20} - 1$ QRSS. 01: $2^{15} - 1$ PRBS. 10: $2^{11} - 1$ PRBS. 11: ARB. (default)

**ARBL - Arbitrary Pattern Generation / Detection Low-Byte Register**

Address: 012H, 052H, 092H, 0D2H, 112H, 152H, 192H, 1D2H, (CH1~CH8) 212H, 252H, 292H, 2D2H, 312H, 352H, 392H, (CH9~CH15) 7D2H (CH0)							
Type: Read / Write Default Value: 55H							
7	6	5	4	3	2	1	0
ARB7	ARB6	ARB5	ARB4	ARB3	ARB2	ARB1	ARB0
Bit	Name	Description					
7 - 0	ARB[7:0]	These bits, together with the ARB[23:8] bits, define the ARB pattern to be generated or detected. The ARB23 bit is the first bit to be generated or detected and the ARB0 bit is the last bit to be generated or detected.					

**ARBM - Arbitrary Pattern Generation / Detection Middle-Byte Register**

Address: 013H, 053H, 093H, 0D3H, 113H, 153H, 193H, 1D3H, (CH1~CH8) 213H, 253H, 293H, 2D3H, 313H, 353H, 393H, (CH9~CH15) 7D3H (CH0)							
Type: Read / Write Default Value: 55H							
7	6	5	4	3	2	1	0
ARB15	ARB14	ARB13	ARB12	ARB11	ARB10	ARB9	ARB8
Bit	Name	Description					
7 - 0	ARB[15:8]	(Refer to the description of the ARBL register.)					

**ARBH - Arbitrary Pattern Generation / Detection High-Byte Register**

Address: 014H, 054H, 094H, 0D4H, 114H, 154H, 194H, 1D4H, (CH1~CH8) 214H, 254H, 294H, 2D4H, 314H, 354H, 394H, (CH9~CH15) 7D4H (CH0)							
Type: Read / Write Default Value: 55H							
7	6	5	4	3	2	1	0
ARB23	ARB22	ARB21	ARB20	ARB19	ARB18	ARB17	ARB16
Bit	Name	Description					
7 - 0	ARB[23:16]	(Refer to the description of the ARBL register.)					

**IBL - Inband Loopback Control Register**

Address: 015H, 055H, 095H, 0D5H, 115H, 155H, 195H, 1D5H, (CH1~CH8) 215H, 255H, 295H, 2D5H, 315H, 355H, 395H, (CH9~CH15) 7D5H (CH0)							
Type: Read / Write Default Value: 01H							
7	6	5	4	3	2	1	0
-	-	IBGL1	IBGL0	IBAL1	IBAL0	IBDL1	IBDL0
Bit	Name	Description					
7 - 6	-	Reserved.					
5 - 4	IBGL[1:0]	These bits define the length of the valid IB generation code programmed in the IBG[7:0] bits (b7~0, IBG,...). 00: 5-bit long in the IBG[4:0] bits (b4~0, IBG,...). (default) 01: 6-bit long in the IBG[5:0] bits (b5~0, IBG,...). 10: 7-bit long in the IBG[6:0] bits (b6~0, IBG,...). 11: 8-bit long in the IBG[7:0] bits (b7~0, IBG,...).					
3 - 2	IBAL[1:0]	These bits define the length of the valid target activate IB detection code programmed in the IBA[7:0] bits (b7~0, IBDA,...). 00: 5-bit long in the IBA[4:0] bits (b4~0, IBDA,...). (default) 01: 6-bit long in the IBA[5:0] bits (b5~0, IBDA,...). 10: 7-bit long in the IBA[6:0] bits (b6~0, IBDA,...). 11: 8-bit long in the IBA[7:0] bits (b7~0, IBDA,...).					
1 - 0	IBDL[1:0]	These bits define the length of the valid target deactivate IB detection code programmed in the IBD[7:0] bits (b7~0, IBDD,...). 00: 5-bit long in the IBD[4:0] bits (b4~0, IBDD,...). 01: 6-bit long in the IBD[5:0] bits (b5~0, IBDD,...). (default) 10: 7-bit long in the IBD[6:0] bits (b6~0, IBDD,...). 11: 8-bit long in the IBD[7:0] bits (b7~0, IBDD,...).					

**IBG - Inband Loopback Generation Code Definition Register**

Address: 016H, 056H, 096H, 0D6H, 116H, 156H, 196H, 1D6H, (CH1~CH8) 216H, 256H, 296H, 2D6H, 316H, 356H, 396H, (CH9~CH15) 7D6H (CH0)							
Type: Read / Write Default Value: 01H							
7	6	5	4	3	2	1	0
IBG7	IBG6	IBG5	IBG4	IBG3	IBG2	IBG1	IBG0
Bit	Name	Description					
7 - 0	IBG[7:0]	The IBG[X:0] bits define the content of the IB generation code. The 'X' is determined by the IBGL[1:0] bits (b5~4, IBL,...). The IBG0 bit is the last bit to be generated. The code is generated repeatedly until the IB generation is stopped.					

**IBDA - Inband Loopback Detection Target Activate Code Definition Register**

Address: 017H, 057H, 097H, 0D7H, 117H, 157H, 197H, 1D7H, (CH1~CH8) 217H, 257H, 297H, 2D7H, 317H, 357H, 397H, (CH9~CH15) 7D7H (CH0)							
Type: Read / Write Default Value: 01H							
7	6	5	4	3	2	1	0
IBA7	IBA6	IBA5	IBA4	IBA3	IBA2	IBA1	IBA0
Bit	Name	Description					
7 - 0	IBA[7:0]	The IBA[X:0] bits define the content of the target activate IB detection code. The 'X' is determined by the IBAL[1:0] bits (b3~2, IBL,...). The IBA0 bit is the last bit to be detected.					

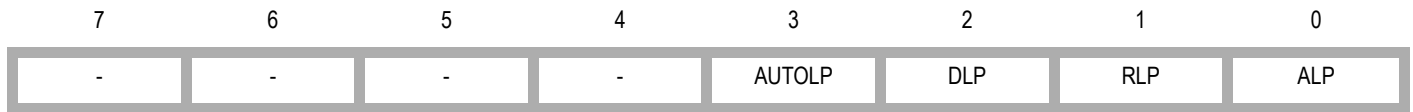
**IBDD - Inband Loopback Detection Target Deactivate Code Definition Register**

Address: 018H, 058H, 098H, 0D8H, 118H, 158H, 198H, 1D8H, (CH1~CH8) 218H, 258H, 298H, 2D8H, 318H, 358H, 398H, (CH9~CH15) 7D8H (CH0)							
Type: Read / Write Default Value: 09H							
7	6	5	4	3	2	1	0
IBD7	IBD6	IBD5	IBD4	IBD3	IBD2	IBD1	IBD0
Bit	Name	Description					
7 - 0	IBD[7:0]	The IBD[X:0] bits define the content of the target deactivate IB detection code. The 'X' is determined by the IBDL[1:0] bits (b1~0, IBL,...). The IBD0 bit is the last bit to be detected.					

**LOOP - Loopback Control Register**

Address: 019H, 059H, 099H, 0D9H, 119H, 159H, 199H, 1D9H, (CH1~CH8)  
 219H, 259H, 299H, 2D9H, 319H, 359H, 399H, (CH9~CH15)  
 7D9H (CH0)

Type: Read / Write  
 Default Value: 00H

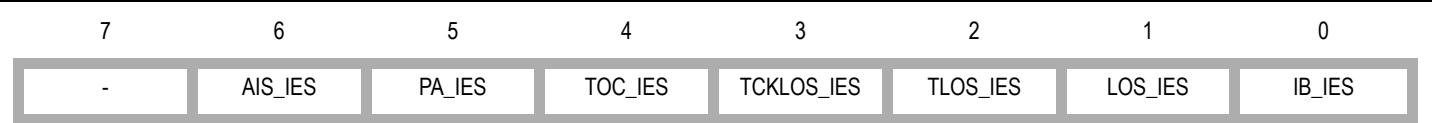


Bit	Name	Description
7 - 4	-	Reserved.
3	AUTOLP	This bit determines whether automatic Digital/Remote Loopback is enabled. 0: Automatic Digital/Remote Loopback is disabled. (default) 1: Automatic Digital/Remote Loopback is enabled. The corresponding channel will enter Digital/Remote Loopback when the activate IB code is detected in the transmit/receive path for more than 5.1 sec.; and will return from Digital/Remote Loopback when the deactivate IB code is detected in the transmit/receive path for more than 5.1 sec.
2	DLP	This bit controls whether Digital Loopback is enabled. 0: Disable. (default) 1: Enable.
1	RLP	This bit controls whether Remote Loopback is enabled. 0: Disable. (default) 1: Enable.
0	ALP	This bit controls whether Analog Loopback is enabled. 0: Disable. (default) 1: Enable.

**INTES - Interrupt Trigger Edges Select Register**

Address: 01AH, 05AH, 09AH, 0DAH, 11AH, 15AH, 19AH, 1DAH, (CH1~CH8)  
 21AH, 25AH, 29AH, 2DAH, 31AH, 35AH, 39AH, (CH9~CH15)  
 7DAH (CH0)

Type: Read / Write  
 Default Value: 00H



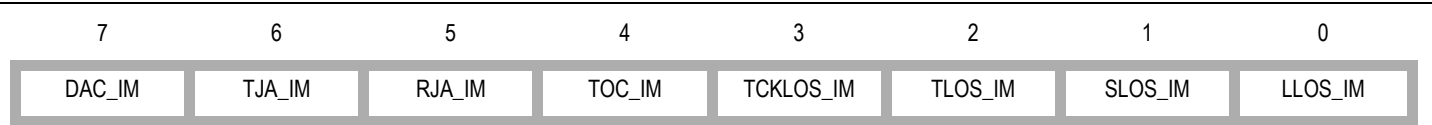
Bit	Name	Description
7	-	Reserved.
6	AIS_IES	This bit selects the transition edge of the LAIS_S bit (b6, STAT1,...) and the SAIS_S bit (b7, STAT1,...). 0: A transition from '0' to '1' on the LAIS_S bit (b6, STAT1,...) / the SAIS_S bit (b7, STAT1,...) will set the LAIS_IS bit (b6, INTS1,...) / the SAIS_IS bit (b7, INTS1,...) to '1' respectively. (default) 1: Any transition from '0' to '1' or from '1' to '0' on the LAIS_S bit (b6, STAT1,...) / the SAIS_S bit (b7, STAT1,...) will set the LAIS_IS bit (b6, INTS1,...) / the SAIS_IS bit (b7, INTS1,...) to '1' respectively.
5	PA_IES	This bit selects the transition edge of the PA_S bit (b5, STAT1,...). 0: A transition from '0' to '1' on the PA_S bit (b5, STAT1,...) will set the PA_IS bit (b5, INTS1,...) to '1'. (default) 1: Any transition from '0' to '1' or from '1' to '0' on the PA_S bit (b5, STAT1,...) will set the PA_IS bit (b5, INTS1,...) to '1'.
4	TOC_IES	This bit selects the transition edge of the TOC_S bit (b4, STAT0,...). 0: A transition from '0' to '1' on the TOC_S bit (b4, STAT0,...) will set the TOC_IS bit (b4, INTS0,...) to '1'. (default) 1: Any transition from '0' to '1' or from '1' to '0' on the TOC_S bit (b4, STAT0,...) will set the TOC_IS bit (b4, INTS0,...) to '1'.
3	TCKLOS_IES	This bit selects the transition edge of the TCKLOS_S bit (b3, STAT0,...). 0: A transition from '0' to '1' on the TCKLOS_S bit (b3, STAT0,...) will set the TCKLOS_IS bit (b3, INTS0,...) to '1'. (default) 1: Any transition from '0' to '1' or from '1' to '0' on the TCKLOS_S bit (b3, STAT0,...) will set the TCKLOS_IS bit (b3, INTS0,...) to '1'.
2	TLOS_IES	This bit selects the transition edge of the TLOS_S bit (b2, STAT0,...). 0: A transition from '0' to '1' on the TLOS_S bit (b2, STAT0,...) will set the TLOS_IS bit (b2, INTS0,...) to '1'. (default) 1: Any transition from '0' to '1' or from '1' to '0' on the TLOS_S bit (b2, STAT0,...) will set the TLOS_IS bit (b2, INTS0,...) to '1'.
1	LOS_IES	This bit selects the transition edge of the LLOS_S bit (b0, STAT0,...) and the SLOS_S bit (b1, STAT0,...). 0: A transition from '0' to '1' on the LLOS_S bit (b0, STAT0,...) / the SLOS_S bit (b1, STAT0,...) will set the LLOS_IS bit (b0, INTS0,...) / the SLOS_IS bit (b1, INTS0,...) to '1' respectively. (default) 1: Any transition from '0' to '1' or from '1' to '0' on the LLOS_S bit (b0, STAT0,...) / the SLOS_S bit (b1, STAT0,...) will set the LLOS_IS bit (b0, INTS0,...) / the SLOS_IS bit (b1, INTS0,...) to '1' respectively.
0	IB_IES	This bit selects the transition edge of the IBA_S bit (b1, STAT1,...) and the IBD_S bit (b0, STAT1,...). 0: A transition from '0' to '1' on the IBA_S bit (b1, STAT1,...) / the IBD_S bit (b0, STAT1,...) will set the IBA_IS bit (b1, INTS1,...) / the IBD_IS bit (b0, INTS1,...) to '1' respectively. (default) 1: Any transition from '0' to '1' or from '1' to '0' on the IBA_S bit (b1, STAT1,...) / the IBD_S bit (b0, STAT1,...) will set the IBA_IS bit (b1, INTS1,...) / the IBD_IS bit (b0, INTS1,...) to '1' respectively.



**INTM0 - Interrupt Mask Register 0**

Address: 01BH, 05BH, 09BH, 0DBH, 11BH, 15BH, 19BH, 1DBH, (CH1~CH8)  
 21BH, 25BH, 29BH, 2DBH, 31BH, 35BH, 39BH, (CH9~CH15)  
 7DBH (CH0)

Type: Read / Write  
 Default Value: FFH



Bit	Name	Description
7	DAC_IM	This bit is the waveform amplitude overflow interrupt mask. 0: Interrupt is enabled. 1: Interrupt is masked. (default)
6	TJA_IM	This bit is the TJA FIFO overflow and underflow interrupt mask. 0: Interrupt is enabled. 1: Interrupt is masked. (default)
5	RJA_IM	This bit is the RJA FIFO overflow and underflow interrupt mask. 0: Interrupt is enabled. 1: Interrupt is masked. (default)
4	TOC_IM	This bit is the Line Driver TOC interrupt mask. 0: Interrupt is enabled. 1: Interrupt is masked. (default)
3	TCKLOS_IM	This bit is the TCLKn missing interrupt mask. 0: Interrupt is enabled. 1: Interrupt is masked. (default)
2	TLOS_IM	This bit is the TLOS interrupt mask. 0: Interrupt is enabled. 1: Interrupt is masked. (default)
1	SLOS_IM	This bit is the SLOS interrupt mask. 0: Interrupt is enabled. 1: Interrupt is masked. (default)
0	LLOS_IM	This bit is the LLOS interrupt mask. 0: Interrupt is enabled. 1: Interrupt is masked. (default)

**INTM1 - Interrupt Mask Register 1**

Address: 01CH, 05CH, 09CH, 0DCH, 11CH, 15CH, 19CH, 1DCH, (CH1~CH8)  
 21CH, 25CH, 29CH, 2DCH, 31CH, 35CH, 39CH, (CH9~CH15)  
 7DCH (CH0)  
 Type: Read / Write  
 Default Value: EFH

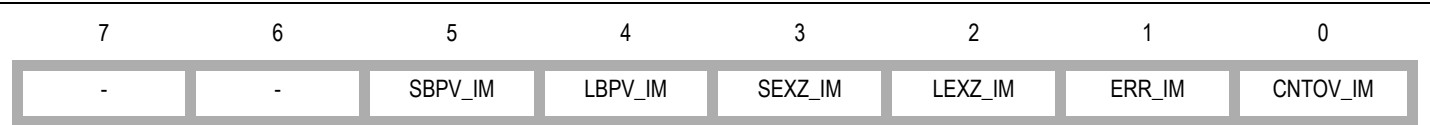


Bit	Name	Description
7	SAIS_IM	This bit is the SAIS interrupt mask. 0: Interrupt is enabled. 1: Interrupt is masked. (default)
6	LAIS_IM	This bit is the LAIS interrupt mask. 0: Interrupt is enabled. 1: Interrupt is masked. (default)
5	PA_IM	This bit is the PRBS/ARB pattern synchronization interrupt mask. 0: Interrupt is enabled. 1: Interrupt is masked. (default)
4 - 2	-	Reserved.
1	IBA_IM	This bit is the activate IB code interrupt mask. 0: Interrupt is enabled. 1: Interrupt is masked. (default)
0	IBD_IM	This bit is the deactivate IB code interrupt mask. 0: Interrupt is enabled. 1: Interrupt is masked. (default)

**INTM2 - Interrupt Mask Register 2**

Address: 01DH, 05DH, 09DH, 0DDH, 11DH, 15DH, 19DH, 1DDH, (CH1~CH8)  
 21DH, 25DH, 29DH, 2DDH, 31DH, 35DH, 39DH, (CH9~CH15)  
 7DDH (CH0)

Type: Read / Write  
 Default Value: 3FH

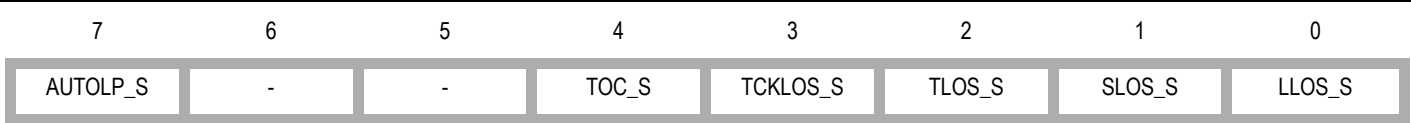


Bit	Name	Description
7 - 6	-	Reserved.
5	SBPV_IM	This bit is the SBPV interrupt mask. 0: Interrupt is enabled. 1: Interrupt is masked. (default)
4	LBPV_IM	This bit is the LBPV interrupt mask. 0: Interrupt is enabled. 1: Interrupt is masked. (default)
3	SEXZ_IM	This bit is the SEXZ interrupt mask. 0: Interrupt is enabled. 1: Interrupt is masked. (default)
2	LEXZ_IM	This bit is the LEXZ interrupt mask. 0: Interrupt is enabled. 1: Interrupt is masked. (default)
1	ERR_IM	This bit is the PRBS/ARB error interrupt mask. 0: Interrupt is enabled. 1: Interrupt is masked. (default)
0	CNTOV_IM	This bit is the ERRCH and ERRCL registers overflow interrupt mask. 0: Interrupt is enabled. 1: Interrupt is masked. (default)

**STAT0 - Status Register 0**

Address: 01EH, 05EH, 09EH, 0DEH, 11EH, 15EH, 19EH, 1DEH, (CH1~CH8)  
 21EH, 25EH, 29EH, 2DEH, 31EH, 35EH, 39EH, (CH9~CH15)  
 7DEH (CH0)

Type: Read  
 Default Value: 00H



Bit	Name	Description
7	AUTOLP_S	This bit indicates the automatic Digital/Remote Loopback status. 0: Out of automatic Digital/Remote Loopback. (default) 1: In automatic Digital/Remote Loopback.
6 - 5	-	Reserved.
4	TOC_S	This bit indicates the TOC status. 0: No TOC is detected. (default) 1: TOC is detected.
3	TCKLOS_S	This bit indicates the TCLKn missing status. 0: TCLKn is not missing. (default) 1: TCLKn is missing.
2	TLOS_S	This bit indicates the TLOS status. 0: No TLOS is detected. (default) 1: TLOS is detected.
1	SLOS_S	This bit indicates the SLOS status. 0: No SLOS is detected. (default) 1: SLOS is detected.
0	LLOS_S	This bit indicates the LLOS status. 0: No LLOS is detected. (default) 1: LLOS is detected.

**STAT1 - Status Register 1**

Address: 01FH, 05FH, 09FH, 0DFH, 11FH, 15FH, 19FH, 1DFH, (CH1~CH8) 21FH, 25FH, 29FH, 2DFH, 31FH, 35FH, 39FH, (CH9~CH15) 7DFH (CH0)							
Type: Read Default Value: 00H							
7	6	5	4	3	2	1	0
SAIS_S	LAIS_S	PA_S	-	-	-	IBA_S	IBD_S
Bit	Name	Description					
7	SAIS_S	This bit indicates the SAIS status. 0: No SAIS is detected. (default) 1: SAIS is detected.					
6	LAIS_S	This bit indicates the LAIS status. 0: No LAIS is detected. (default) 1: LAIS is detected.					
5	PA_S	This bit indicates the PRBS/ARB pattern synchronization status. 0: The PRBS/ARB pattern is out of synchronization. (default) 1: The PRBS/ARB pattern is in synchronization.					
4 - 2	-	Reserved.					
1	IBA_S	This bit indicates the activate IB code status. 0: No activate IB code is detected. (default) 1: Activate IB code is detected for more than 40 ms when the AUTOLP bit (b3, LOOP,...) is '0' or activate IB code is detected for more than 5.1 sec. when the AUTOLP bit (b3, LOOP,...) is '1'.					
0	IBD_S	This bit indicates the deactivate IB code status. 0: No deactivate IB code is detected. (default) 1: Deactivate IB code is detected for more than 30 ms (in E1 mode) when the AUTOLP bit (b3, LOOP,...) is '0' or deactivate IB code is detected for more than 5.1 sec. when the AUTOLP bit (b3, LOOP,...) is '1'.					

**INTS0 - Interrupt Status Register 0**

Address: 020H, 060H, 0A0H, 0E0H, 120H, 160H, 1A0H, 1E0H, (CH1~CH8)  
 220H, 260H, 2A0H, 2E0H, 320H, 360H, 3A0H, (CH9~CH15)  
 7E0H (CH0)

Type: Read / Write  
 Default Value: 00H



Bit	Name	Description
7	DAC_IS	This bit indicates the interrupt status of the waveform amplitude overflow. 0: No waveform amplitude overflow interrupt is generated; or a '1' is written to this bit. (default) 1: Waveform amplitude overflow interrupt is generated and is reported by the $\overline{\text{INT}}$ pin.
6	TJA_IS	This bit indicates the interrupt status of the TJA FIFO overflow or underflow. 0: No TJA FIFO overflow or underflow interrupt is generated; or a '1' is written to this bit. (default) 1: TJA FIFO overflow or underflow interrupt is generated and is reported by the $\overline{\text{INT}}$ pin.
5	RJA_IS	This bit indicates the interrupt status of the RJA FIFO overflow or underflow. 0: No RJA FIFO overflow or underflow interrupt is generated; or a '1' is written to this bit. (default) 1: RJA FIFO overflow or underflow interrupt is generated and is reported by the $\overline{\text{INT}}$ pin.
4	TOC_IS	This bit indicates the interrupt status of the Line Driver TOC. 0: No TOC interrupt is generated; or a '1' is written to this bit. (default) 1: TOC interrupt is generated and is reported by the $\overline{\text{INT}}$ pin. When the TOC_IES bit (b4, INTES,...) is '0', a transition from '0' to '1' on the TOC_S bit (b4, STAT0,...) set this bit to '1'; when the TOC_IES bit (b4, INTES,...) is '1', any transition (from '0' to '1' or from '1' to '0') on the TOC_S bit (b4, STAT0,...) set this bit to '1'.
3	TCKLOS_IS	This bit indicates the interrupt status of the TCLKn missing. 0: No TCLKn missing interrupt is generated; or a '1' is written to this bit. (default) 1: TCLKn missing interrupt is generated and is reported by the $\overline{\text{INT}}$ pin. When the TCKLOS_IES bit (b3, INTES,...) is '0', a transition from '0' to '1' on the TCKLOS_S bit (b3, STAT0,...) set this bit to '1'; when the TCKLOS_IES bit (b3, INTES,...) is '1', any transition (from '0' to '1' or from '1' to '0') on the TCKLOS_S bit (b3, STAT0,...) set this bit to '1'.
2	TLOS_IS	This bit indicates the interrupt status of TLOS. 0: No TLOS interrupt is generated; or a '1' is written to this bit. (default) 1: TLOS interrupt is generated and is reported by the $\overline{\text{INT}}$ pin. When the TLOS_IES bit (b2, INTES,...) is '0', a transition from '0' to '1' on the TLOS_S bit (b2, STAT0,...) set this bit to '1'; when the TLOS_IES bit (b2, INTES,...) is '1', any transition (from '0' to '1' or from '1' to '0') on the TLOS_S bit (b2, STAT0,...) set this bit to '1'.
1	SLOS_IS	This bit indicates the interrupt status of the SLOS. 0: No SLOS interrupt is generated; or a '1' is written to this bit. (default) 1: SLOS interrupt is generated and is reported by the $\overline{\text{INT}}$ pin. When the LOS_IES bit (b1, INTES,...) is '0', a transition from '0' to '1' on the SLOS_S bit (b1, STAT0,...) set this bit to '1'; when the LOS_IES bit (b1, INTES,...) is '1', any transition (from '0' to '1' or from '1' to '0') on the SLOS_S bit (b1, STAT0,...) set this bit to '1'.
0	LLOS_IS	This bit indicates the interrupt status of the LLOS. 0: No LLOS interrupt is generated; or a '1' is written to this bit. (default) 1: LLOS interrupt is generated and is reported by the $\overline{\text{INT}}$ pin. When the LOS_IES bit (b1, INTES,...) is '0', a transition from '0' to '1' on the LLOS_S bit (b0, STAT0,...) set this bit to '1'; when the LOS_IES bit (b1, INTES,...) is '1', any transition (from '0' to '1' or from '1' to '0') on the LLOS_S bit (b0, STAT0,...) set this bit to '1'.

**INTS1 - Interrupt Status Register 1**

Address: 021H, 061H, 0A1H, 0E1H, 121H, 161H, 1A1H, 1E1H, (CH1~CH8)  
 221H, 261H, 2A1H, 2E1H, 321H, 361H, 3A1H, (CH9~CH15)  
 7E1H (CH0)

Type: Read / Write  
 Default Value: 00H

7	6	5	4	3	2	1	0
SAIS_IS	LAIS_IS	PA_IS	-	-	-	IBA_IS	IBD_IS

Bit	Name	Description
7	SAIS_IS	This bit indicates the interrupt status of the SAIS. 0: No SAIS interrupt is generated; or a '1' is written to this bit. (default) 1: SAIS interrupt is generated and is reported by the $\overline{INT}$ pin. When the AIS_IES bit (b6, INTES,...) is '0', a transition from '0' to '1' on the SAIS_S bit (b7, STAT1,...) set this bit to '1'; when the AIS_IES bit (b6, INTES,...) is '1', any transition (from '0' to '1' or from '1' to '0') on the SAIS_S bit (b7, STAT1,...) set this bit to '1'.
6	LAIS_IS	This bit indicates the interrupt status of the LAIS. 0: No LAIS interrupt is generated; or a '1' is written to this bit. (default) 1: LAIS interrupt is generated and is reported by the $\overline{INT}$ pin. When the AIS_IES bit (b6, INTES,...) is '0', a transition from '0' to '1' on the LAIS_S bit (b6, STAT1,...) set this bit to '1'; when the AIS_IES bit (b6, INTES,...) is '1', any transition (from '0' to '1' or from '1' to '0') on the LAIS_S bit (b6, STAT1,...) set this bit to '1'.
5	PA_IS	This bit indicates the interrupt status of the PRBS/ARB pattern synchronization. 0: No PRBS/ARB pattern synchronization interrupt is generated; or a '1' is written to this bit. (default) 1: PRBS/ARB pattern synchronization interrupt is generated and is reported by the $\overline{INT}$ pin. When the PA_IES bit (b5, INTES,...) is '0', a transition from '0' to '1' on the PA_S bit (b5, STAT1,...) set this bit to '1'; when the PA_IES bit (b5, INTES,...) is '1', any transition (from '0' to '1' or from '1' to '0') on the PA_S bit (b5, STAT1,...) set this bit to '1'.
4 - 2	-	Reserved.
1	IBA_IS	This bit indicates the interrupt status of the activate IB code. 0: No activate IB code interrupt is generated; or a '1' is written to this bit. (default) 1: Activate IB code interrupt is generated and is reported by the $\overline{INT}$ pin. When the IB_IES bit (b0, INTES,...) is '0', a transition from '0' to '1' on the IBA_S bit (b1, STAT1,...) set this bit to '1'; when the IB_IES bit (b0, INTES,...) is '1', any transition (from '0' to '1' or from '1' to '0') on the IBA_S bit (b1, STAT1,...) set this bit to '1'.
0	IBD_IS	This bit indicates the interrupt status of the deactivate IB code. 0: No deactivate IB code interrupt is generated; or a '1' is written to this bit. (default) 1: Deactivate IB code interrupt is generated and is reported by the $\overline{INT}$ pin. When the IB_IES bit (b0, INTES,...) is '0', a transition from '0' to '1' on the IBD_S bit (b0, STAT1,...) set this bit to '1'; when the IB_IES bit (b0, INTES,...) is '1', any transition (from '0' to '1' or from '1' to '0') on the IBD_S bit (b0, STAT1,...) set this bit to '1'.

**INTS2 - Interrupt Status Register 2**

Address: 022H, 062H, 0A2H, 0E2H, 122H, 162H, 1A2H, 1E2H, (CH1~CH8)  
 222H, 262H, 2A2H, 2E2H, 322H, 362H, 3A2H, (CH9~CH15)  
 7E2H (CH0)  
 Type: Read / Write  
 Default Value: 00H



Bit	Name	Description
7 - 6	-	Reserved.
5	SBPV_IS	This bit indicates the interrupt status of the SBPV. 0: No SBPV interrupt is generated; or a '1' is written to this bit. (default) 1: SBPV interrupt is generated and is reported by the $\overline{\text{INT}}$ pin.
4	LBPV_IS	This bit indicates the interrupt status of the LBPV. 0: No LBPV interrupt is generated; or a '1' is written to this bit. (default) 1: LBPV interrupt is generated and is reported by the $\overline{\text{INT}}$ pin.
3	SEXZ_IS	This bit indicates the interrupt status of the SEXZ. 0: No SEXZ interrupt is generated; or a '1' is written to this bit. (default) 1: SEXZ interrupt is generated and is reported by the $\overline{\text{INT}}$ pin.
2	LEXZ_IS	This bit indicates the interrupt status of the LEXZ. 0: No LEXZ interrupt is generated; or a '1' is written to this bit. (default) 1: LEXZ interrupt is generated and is reported by the $\overline{\text{INT}}$ pin.
1	ERR_IS	This bit indicates the interrupt status of the PRBS/ARB error. 0: No PRBS/ARB error interrupt is generated; or a '1' is written to this bit. (default) 1: PRBS/ARB error interrupt is generated and is reported by the $\overline{\text{INT}}$ pin.
0	CNTOV_IS	This bit indicates the interrupt status of the ERRCH and ERRCL registers overflow. 0: No ERRCH or ERRCL register overflow interrupt is generated; or a '1' is written to this bit. (default) 1: ERRCH and ERRCL registers overflow interrupt is generated and is reported by the $\overline{\text{INT}}$ pin.



**ERRCL - Error Counter Low-Byte Register**

Address: 023H, 063H, 0A3H, 0E3H, 123H, 163H, 1A3H, 1E3H, (CH1~CH8) 223H, 263H, 2A3H, 2E3H, 323H, 363H, 3A3H, (CH9~CH15) 7E3H (CH0)							
Type: Read Default Value: 00H							
7	6	5	4	3	2	1	0
ERRC7	ERRC6	ERRC5	ERRC4	ERRC3	ERRC2	ERRC1	ERRC0
Bit	Name	Description					
7 - 0	ERRC[7:0]	These bits, together with the ERRC[15:8] bits, reflect the accumulated error number in the internal Error Counter. They are updated automatically or manually, as determined by the CNT_MD bit (b1, ERR,...). They should be read in the next round of error counting; otherwise, they will be overwritten.					

**ERRCH - Error Counter High-Byte Register**

Address: 024H, 064H, 0A4H, 0E4H, 124H, 164H, 1A4H, 1E4H, (CH1~CH8) 224H, 264H, 2A4H, 2E4H, 324H, 364H, 3A4H, (CH9~CH15) 7E4H (CH0)							
Type: Read Default Value: 00H							
7	6	5	4	3	2	1	0
ERRC15	ERRC14	ERRC13	ERRC12	ERRC11	ERRC10	ERRC9	ERRC8
Bit	Name	Description					
7 - 0	ERRC[15:8]	(Refer to the description of the ERRCL register.)					

**JM - Jitter Measurement Configuration For Channel 0 Register**

Address: 7E5H							
Type: Read / Write							
Default Value: 00H							
7	6	5	4	3	2	1	0
-	-	-	-	-	JM_STOP	JM_MD	JM_BW
Bit	Name	Description					
7 - 3	-	Reserved.					
2	JM_STOP	This bit is valid only when the JM_MD bit (b1, JM) is '0'. A transition from '0' to '1' on this bit updates the JIT_PH, JIT_PL and JIT_NH, JIT_NL registers. This bit must be cleared before the next round.					
1	JM_MD	This bit selects the jitter measurement period. 0: The period is determined manually by setting the JM_STOP bit (b2, JM). (default) 1: The period is one second automatically.					
0	JM_BW	This bit selects the bandwidth of the measured jitter. 0: 20 Hz ~ 100 KHz (in E1 mode). (default) 1: 18 KHz ~ 100 KHz (in E1 mode).					

**JIT\_PL - Positive Peak Jitter Measurement Low-Byte Register**

Address: 7E6H							
Type: Read							
Default Value: 00H							
7	6	5	4	3	2	1	0
JIT_P7	JIT_P6	JIT_P5	JIT_P4	JIT_P3	JIT_P2	JIT_P1	JIT_P0
Bit	Name	Description					
7 - 0	JIT_P[7:0]	These bits, together with the JIT_P[11:8] bits, reflect the greatest positive peak value of the demodulated jitter signal which is measured by channel 0. They are updated automatically or manually, as determined by the JM_MD bit (b1, JM). They should be read in the next round of jitter measurement; otherwise, they will be overwritten. The relationship between the greatest positive peak value and the indication in these bits is: Positive Peak = [JIT_PH, JIT_PL] / 16 (Upp)					

**JIT\_PH - Positive Peak Jitter Measurement High-Byte Register**

Address: 7E7H							
Type: Read							
Default Value: 00H							
7	6	5	4	3	2	1	0
-	-	-	-	JIT_P11	JIT_P10	JIT_P9	JIT_P8
Bit	Name	Description					
7 - 4	-	Reserved.					
3 - 0	JIT_P[11:8]	(Refer to the description of the JIT_PL register.)					

**JIT\_NL - Negative Peak Jitter Measurement Low-Byte Register**

Address: 7E8H							
Type: Read							
Default Value: 00H							
7	6	5	4	3	2	1	0
JIT_N7	JIT_N6	JIT_N5	JIT_N4	JIT_N3	JIT_N2	JIT_N1	JIT_N0
Bit	Name	Description					
7 - 0	JIT_N[7:0]	<p>These bits, together with the JIT_N[11:8] bits, reflect the greatest negative peak value of the demodulated jitter signal which is measured by channel 0. They are updated automatically or manually, as determined by the JM_MD bit (b1, JM). They should be read in the next round of jitter measurement; otherwise, they will be overwritten.</p> <p>The relationship between the greatest negative peak value and the indication in these bits is:                      Negative Peak = [JIT_NH, JIT_NL] / 16 (Upp)</p>					

**JIT\_NH - Negative Peak Jitter Measurement High-Byte Register**

Address: 7E9H							
Type: Read							
Default Value: 00H							
7	6	5	4	3	2	1	0
-	-	-	-	JIT_N11	JIT_N10	JIT_N9	JIT_N8
Bit	Name	Description					
7 - 4	-	Reserved.					
3 - 0	JIT_N[11:8]	(Refer to the description of the JIT_NL register.)					

## 6 JTAG

The IDT82P20516 supports the digital Boundary Scan Specification as described in the IEEE 1149.1 standards.

The boundary scan architecture consists of data and instruction registers plus a Test Access Port (TAP) controller. The control of the TAP is achieved through signals applied to the Test Mode Select (TMS) and Test Clock (TCK) input pins. Data is shifted into the registers via the Test

Data Input (TDI) pin, and shifted out of the registers via the Test Data Output (TDO) pin. Both TDI and TDO are clocked at a rate determined by TCK.

The JTAG boundary scan registers include BSR (Boundary Scan Register), DIR (Device Identification Register), BR (Bypass Register) and IR (Instruction Register). These will be described in the following pages. Refer to Figure-34 for architecture.

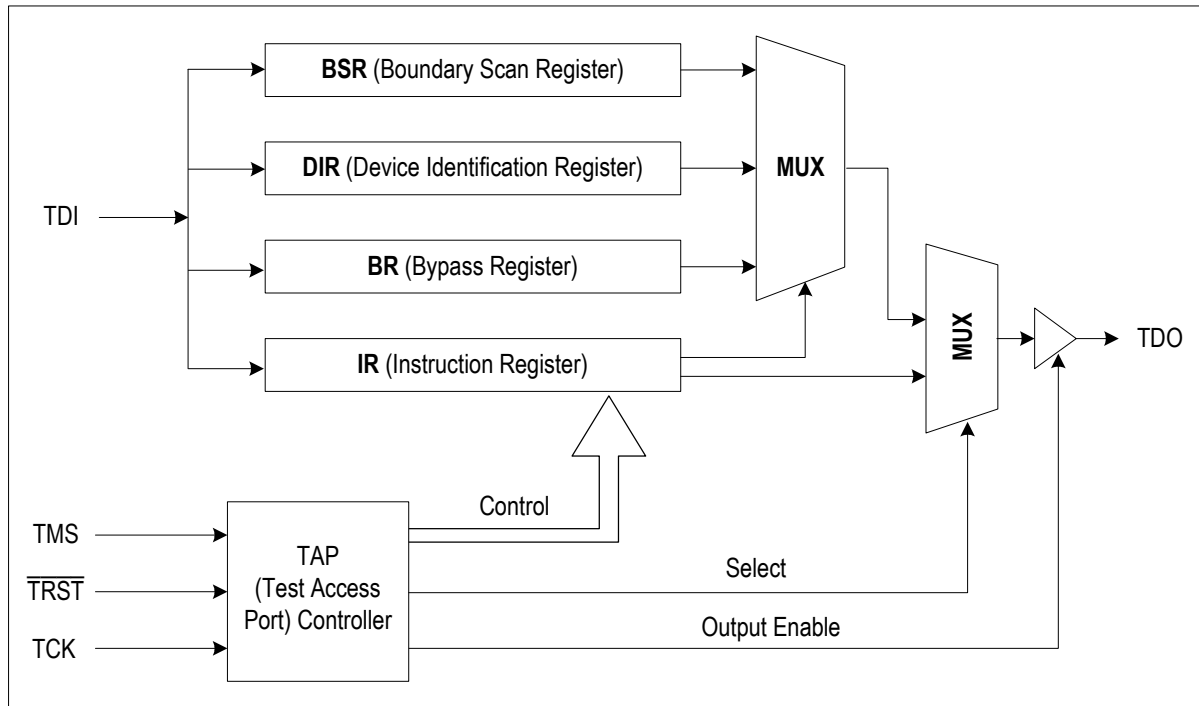


Figure-34 JTAG Architecture

### 6.1 JTAG INSTRUCTION REGISTER (IR)

The IR with instruction decode block is used to select the test to be executed or the data register to be accessed or both.

The instructions include: EXTEST, SAMPLE/PRELOAD, IDCODE, BYPASS, CLAMP and HIGHZ.

### 6.2 JTAG DATA REGISTER

#### 6.2.1 DEVICE IDENTIFICATION REGISTER (IDR)

The IDR can be set to define the Version, the Part Number, the Manufacturer Identity and a fixed bit.

#### 6.2.2 BYPASS REGISTER (BYP)

The BYP consists of a single bit. It can provide a serial path between the TDI input and the TDO output. Bypassing the BYR will reduce test access times.

### 6.2.3 BOUNDARY SCAN REGISTER (BSR)

The bidirectional ports interface to 2 boundary scan cells:

- In cell: The input cell is observable only.
- Out cell: The output cell is controllable and observable.

### 6.3 TEST ACCESS PORT (TAP) CONTROLLER

The TAP controller is a 16-state synchronous state machine. The states include: Test Logic Reset, Run-Test/Idle, Select-DR-Scan, Capture-DR, Shift-DR, Exit1-DR, Pause-DR, Exit2-DR, Update-DR, Select-IR-Scan, Capture-IR, Shift-IR, Exit1-IR, Pause-IR, Exit2-IR and Update-IR.

Figure-35 shows the state diagram. Note that the figure contains two main branches to access either the data or instruction registers. The value shown next to each state transition in this figure states the value present at TMS at each rising edge of TCK.

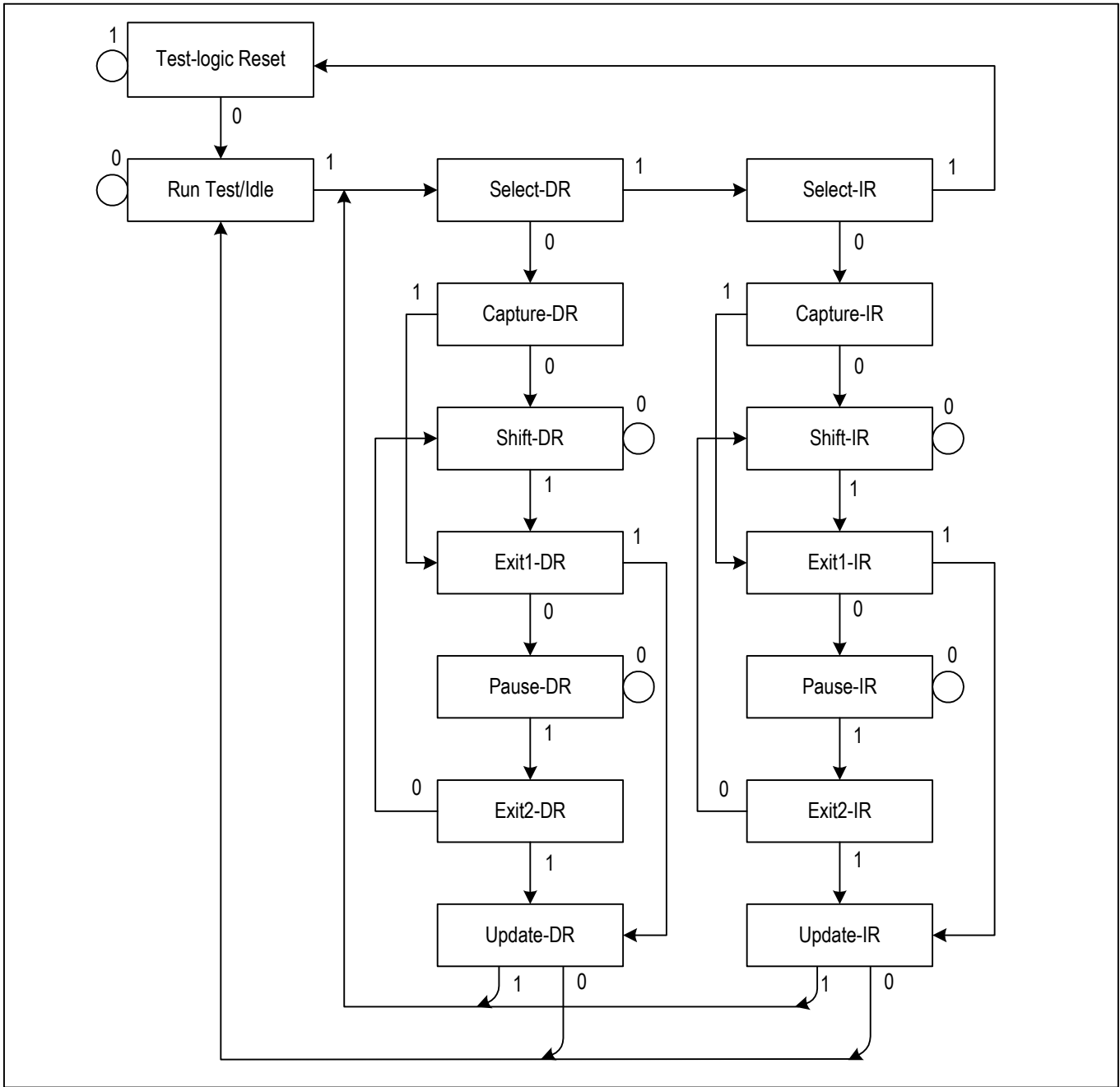


Figure-35 JTAG State Diagram

## 7 THERMAL MANAGEMENT

The device is designed to operate over the industry temperature range -40°C ~ +85°C. To ensure the functionality and reliability of the device, the maximum junction temperature,  $T_{jmax}$ , should not exceed 125°C. In some applications, the device will consume more power and a thermal solution should be provided to ensure the junction temperature  $T_j$  does not exceed  $T_{jmax}$ . Below is a table listing thermal data for the IDT82P20516.

Package	$\theta_{JC}$ (°C/W) <sup>1</sup>	$\theta_{JB}$ (°C/W) <sup>2</sup>	$\theta_{JA}$ (°C/W) <sup>3</sup>	Airflow (m/s)
484-pin BF	4.2	5.3	23.7	0
			18.7	1
			17.0	2
			16.1	3
			15.5	4
			15.0	5

**Note:**

1. Junction-to-Case Thermal Resistance
2. Junction-to-Board Thermal Resistance
3. Junction-to-Ambient Thermal Resistance

### 7.1 JUNCTION TEMPERATURE

Junction temperature  $T_j$  is the temperature of package typically at the geographical center of the chip where the device's electrical circuits are. It can be calculated as follows:

$$\text{Equation 1: } T_j = T_A + P * \theta_{JA}$$

Where:

$\theta_{JA}$  = Junction-to-Ambient Thermal Resistance of the package

$T_j$  = Junction Temperature

$T_A$  = Ambient Temperature

$P$  = Device Power Consumption

For the IDT82P20516, the above values are:

$\theta_{JA} = 23.7$  °C/W (when airflow rate is 0 m/s. See the above table)

$T_{jmax} = 125$  °C

$T_A = -40$  °C ~  $85$  °C

$P$  = Refer to Section 8.3 Device Power Consumption and Dissipation (Typical) 1

### 7.2 EXAMPLE OF JUNCTION TEMPERATURE CALCULATION

Assume:

$$T_A = 85 \text{ }^\circ\text{C}$$

$$\theta_{JA} = 23.7 \text{ }^\circ\text{C/W (airflow: 0 m/s)}$$

$$P = 1.46 \text{ W (E1 120 } \Omega, 100\% \text{ ones, External Impedance matching)}$$

The junction temperature  $T_j$  can be calculated as follows:

$$T_j = T_A + P * \theta_{JA} = 85 \text{ }^\circ\text{C} + 1.46 \text{ W} \times 23.7 \text{ }^\circ\text{C/W} = 119.6 \text{ }^\circ\text{C}$$

The junction temperature of **119.6** °C is below the maximum junction temperature of 125 °C, so no extra heat enhancement is required.

In some operation environments, the calculated junction temperature might exceed the maximum junction temperature of 125 °C and an external thermal solution such as a heatsink is required.

### 7.3 HEATSINK EVALUATION

A heatsink is expanding the surface area of the device to which it is attached.  $\theta_{JA}$  is now a combination of device case and heatsink thermal resistance, as the heat flowing from the die junction to ambient goes through the package and the heatsink.  $\theta_{JA}$  can be calculated as follows:

$$\text{Equation 2: } \theta_{JA} = \theta_{JC} + \theta_{HA}$$

Where:

$\theta_{JC}$  = Junction-to-Case (heatsink) Thermal Resistance

$\theta_{HA}$  = Heatsink-to-Ambient Thermal Resistance

For the IDT82P20516,  $\theta_{JC}$  is 4.2 °C/W.

$\theta_{HA}$  determines which heatsink can be selected to ensure the junction temperature does not exceed  $T_{jmax}$ . According to Equation 1 and 2, the heatsink-to-ambient thermal resistance  $\theta_{HA}$  can be calculated as follows:

$$\text{Equation 3: } \theta_{HA} = (T_j - T_A) / P - \theta_{JC}$$

Assume:

$$T_j = 125 \text{ }^\circ\text{C (} T_{jmax} \text{)}$$

$$T_A = 85 \text{ }^\circ\text{C}$$

$$P = 2.72 \text{ W (E1 75 } \Omega, 100\% \text{ ones, Fully Internal Impedance matching)}$$

$$\theta_{JC} = 4.2 \text{ }^\circ\text{C/W}$$

The Heatsink-to-Ambient thermal resistance  $\theta_{HA}$  can be calculated as follows:

$$\theta_{HA} = (125 \text{ }^\circ\text{C} - 85 \text{ }^\circ\text{C}) / 2.72 \text{ W} - 4.2 \text{ }^\circ\text{C/W} = 10.51 \text{ }^\circ\text{C/W}$$

That is, if a heatsink whose heatsink-to-ambient thermal resistance  $\theta_{HA}$  is below or equal to 10.51 °C/W is used in such operation environment, the junction temperature will not exceed the maximum junction temperature.

## 8 PHYSICAL AND ELECTRICAL SPECIFICATIONS

### 8.1 ABSOLUTE MAXIMUM RATINGS

Symbol	Parameter	Min	Max	Unit
VDDD	Digital Core Power Supply	-0.5	2.2	V
VDDA	Analog Core Power Supply	-0.5	4.6	V
VDDIO	I/O Power Supply	-0.5	4.6	V
VDDT0~15	Power Supply for Transmitter Driver	-0.5	4.6	V
VDDR0~15	Power Supply for Receiver	-0.5	4.6	V
V <sub>in</sub>	Input Voltage, Any Digital Pin	GND - 0.5	6	V
	Input Voltage, Any RTIP and RRING pin <sup>1</sup>	GND - 0.5	VDDR + 0.5	V
	ESD Voltage, Any Pin <sup>2</sup>	2000		V
I <sub>in</sub>	Transient Latch-up Current, Any Pin		100	mA
	Input Current, Any Digital Pin <sup>3</sup>	-10	10	mA
	DC Input Current, Any Analog Pin <sup>3</sup>		±100	mA
P <sub>d</sub>	Maximum Power Dissipation in Package		1.68 <sup>4</sup>	W
T <sub>j</sub>	Junction Temperature		125	°C
T <sub>s</sub>	Storage Temperature	-65	+150	°C

**Note:**  
 1. Reference to ground.  
 2. Human body model.  
 3. Constant input current.  
 4. If device power consumption exceeds this value, a heatsink or a fan must be used. Refer to Chapter 7 Thermal Management.

**Caution:**  
 Exceeding the above values may cause permanent damage. Functional operation under these conditions is not implied. Exposure to absolute maximum rating conditions for extended period may affect device reliability.

## 8.2 RECOMMENDED OPERATING CONDITIONS

Symbol	Parameter	Min	Typ.	Max	Unit
$T_{op}$	Operating Temperature Range	-40		85 <sup>1</sup>	°C
VDDIO	Digital I/O Power Supply	3.13	3.3	3.47	V
VDDA	Analog Core Power Supply	3.13	3.3	3.47	V
VDDD	Digital Core Power Supply	1.71	1.8	1.89	V
VDDT	Power Supply for Transmitter Driver	3.13	3.3	3.47	V
VDDR	Power Supply for Receiver	3.13	3.3	3.47	V
$V_{IL}$	Input Low Voltage	-0.5		0.8	V
$V_{IH}$	Input High Voltage	2.0		VDDIO+0.5	V

**Note:**

1. An external thermal solution such as heatsink may be required depending on the mode of operation. Refer to Chapter 7 Thermal Management.



8.3 DEVICE POWER CONSUMPTION AND DISSIPATION (TYPICAL) <sup>1</sup>

Mode	Parameter	Total Consumption (W)			Total Device Power Dissipation (for Thermal Consideration, W)			Per-Channel Power Down Saving (mW) <sup>2</sup>		
		1.8 V	3.3 V	Total	Fully Internal R120IN=1 <sup>3</sup>	Partially Internal R120IN=0 <sup>4</sup>	External <sup>5</sup>	Fully Internal R120IN=1 <sup>3</sup>	Partially Internal R120IN=0 <sup>4</sup>	External <sup>5</sup>
E1/120 Ω	PRBS	0.18	1.73	1.91	1.91	1.48	1.20	80	60	40
	100% ones	0.18	2.31	2.49	2.49	1.87	1.46	130	90	70
E1/75 Ω	PRBS	0.18	1.86	2.04	2.04	1.77	0.98	90	60	50
	100% ones	0.18	2.54	2.72	2.72	2.33	1.32	150	120	80

**Note:**

1. Test conditions: VDDx (typical) at 25 °C operating temperature (ambient).
2. The R\_OFF bit (b5, RCF0,...) and T\_OFF bit (b5, TCF0,...) are set to '1' to enable per-channel power down.
3. The transmitter is in Internal Impedance Matching mode and the receiver is in Fully Internal Impedance Matching mode. That is, the R120IN bit (b4, RCF0,...) is set to '1'. And the T\_TERM[2:0] bits (b2~0, TCF0,...) and R\_TERM[2:0] bits (b2~0, RCF0,...) are set according to different cable conditions.
4. The transmitter is in Internal Impedance Matching mode and the receiver is in Partially Internal Impedance Matching mode. That is, the R120IN bit (b4, RCF0,...) is set to '0'. And the T\_TERM[2:0] bits (b2~0, TCF0,...) and R\_TERM[2:0] bits (b2~0, RCF0,...) are set according to different cable conditions.
5. For E1 mode, both the transmitter and the receiver are in External Impedance Matching mode. That is, the T\_TERM[2:0] bits (b2~0, TCF0,...) are set to '111' and the R\_TERM[2:0] bits (b2~0, RCF0,...) are set to '1xx'.

8.4 DEVICE POWER CONSUMPTION AND DISSIPATION (MAXIMUM) <sup>1</sup>

Mode	Parameter	Total Consumption (W)			Total Device Power Dissipation (for Thermal Consideration, W)		
		1.89 V	3.47 V	Total	Fully Internal R120IN=1 <sup>2</sup>	Partially Internal R120IN=0 <sup>3</sup>	External <sup>4</sup>
E1/120 Ω	PRBS	0.22	1.82	2.04	2.04	1.68	1.40
	100% ones	0.22	2.43	2.65	2.65	2.08	1.67
E1/75 Ω	PRBS	0.22	1.95	2.17	2.17	1.98	0.98
	100% ones	0.22	2.67	2.89	2.89	2.53	1.37

**Note:**

1. Test conditions: VDDx (maximum) at 85 °C operating temperature (ambient).
2. The transmitter is in Internal Impedance Matching mode and the receiver is in Fully Internal Impedance Matching mode. That is, the R120IN bit (b4, RCF0,...) is set to '1'. And the T\_TERM[2:0] bits (b2~0, TCF0,...) and R\_TERM[2:0] bits (b2~0, RCF0,...) are set according to different cable conditions.
3. The transmitter is in Internal Impedance Matching mode and the receiver is in Partially Internal Impedance Matching mode. That is, the R120IN bit (b4, RCF0,...) is set to '0'. And the T\_TERM[2:0] bits (b2~0, TCF0,...) and R\_TERM[2:0] bits (b2~0, RCF0,...) are set according to different cable conditions.
4. For E1 mode, both the transmitter and the receiver are in External Impedance Matching mode. That is, the T\_TERM[2:0] bits (b2~0, TCF0,...) are set to '111' and the R\_TERM[2:0] bits (b2~0, RCF0,...) are set to '1xx'.

## 8.5 D.C. CHARACTERISTICS

@ TA = -40 to +85 °C, VDDIO = 3.3 V ± 5%, VDDD = 1.8 V ± 5%

Symbol	Parameter	Min	Typ.	Max	Unit	Test Conditions
V <sub>OL</sub>	Output Low Voltage			0.40	V	VDDIO = 3.13 V, I <sub>OL</sub> = 4 mA, 8 mA
V <sub>OH</sub>	Output High Voltage	2.4		VDDIO	V	VDDIO = 3.13 V, I <sub>OH</sub> = 4 mA, 8 mA
V <sub>T+</sub>	Schmitt Trigger Input Low to High Threshold	1.47			V	
V <sub>T-</sub>	Schmitt Trigger Input High to Low Threshold			0.89	V	
R <sub>pu</sub>	Internal Pull-up /Pull-down Resistor	50	70	115	KΩ	
I <sub>IL</sub>	Input Low Current	-1	0	+1	μA	V <sub>IL</sub> = GNDD
I <sub>IH</sub>	Input High Current	-1	0	+1	μA	V <sub>IH</sub> = VDDIO
C <sub>in</sub>	Input Digital Pin Capacitance			10	pF	
C <sub>out</sub>	Output Load Capacitance			50	pF	
C <sub>out</sub>	Output Load Capacitance (bus pins)			100	pF	
I <sub>ZL</sub>	Leakage Current of Digital Output in High-Z mode	-10		10	μA	GNDIO < V <sub>O</sub> < VDDIO
Z <sub>OH</sub>	Output High-Z on TTIPn, TRINGn pins	10			KΩ	

8.6 E1 RECEIVER ELECTRICAL CHARACTERISTICS

Parameter	Min	Typ.	Max	Unit	Test Conditions
Receiver Sensitivity of Receive Differential mode with Cable Loss @ 1024 KHz		15		dB	with Nominal Pulse Amplitude of 3.0 V for 120 Ω and 2.37 V for 75 Ω termination, adding -18 dB interference signal.
Receiver Sensitivity of Receive Single Ended mode with Cable Loss @ 1024 KHz		12		dB	
Signal to Noise Interference Margin	-16			dB	@cable loss 0-6 dB
Analog LOS Level (Normal Mode)	ALOS[2:0]			V <sub>pp</sub>	In Differential mode, measured between RTIP and RRING pins. In Singled Ended mode, measured between RTIP and GNDA pins Refer to Table-10 for LLOS Criteria Declare and Clear.
	000		0.5		
	001 (default)		0.7		
	010		0.9		
	011		1.2		
	100		1.4		
	101		1.6		
	110		1.8		
111		2.0			
LOS hysteresis		0.25			
Analog LOS Level (Line Monitor Mode)	ALOS[2:0]			V <sub>pp</sub>	Measured on the line with the monitor gain set by the MG[1:0] bits (b1~0, RCF2,...) equal to the resistive attenuation. Refer to Table-10 for LLOS Criteria Declare and Clear.
	000		1.0		
	001 (default)		1.4		
	010		1.8		
	011		2.2		
	1xx (reserved)				
LOS hysteresis		0.41			
Allowable Consecutive Zeros before LOS: G.775 I.431 / ETSI300233		32 2048			
LOS Reset	12.5			% ones	G.775, ETSI 300233
Receive Intrinsic Jitter			0.05	U.I.	JA disabled; wide band
Input Jitter Tolerance: 1 Hz ~ 20 Hz 20 Hz ~ 2.4 KHz 18 KHz ~ 100 KHz	80 10 0.6			U.I. U.I. U.I.	G.823, with 6 dB Cable Attenuation
Receiver Differential Input Impedance		2.6		KΩ	@1024 KHz; Rx port is high-Z
Receiver Common Mode Input Impedance to GND		1.6		KΩ	

Parameter	Min	Typ.	Max	Unit	Test Conditions
Receiver Single Ended mode Input Impedance to GND		3.1		K $\Omega$	The RRINGn pins are open.
Receive Return Loss: 51 KHz ~ 102 KHz 102 KHz ~ 2.048 MHz 2.048 MHz ~ 3.072 MHz	12 18 14			dB dB dB	G.703
Receive Path Delay: Single Rail Dual Rail NRZ Dual Rail RZ			6.6 1.8 1.5	U.I. U.I. U.I.	JA Disabled

8.7 E1 TRANSMITTER ELECTRICAL CHARACTERISTICS

Parameter		Min	Typ.	Max	Unit	Test Conditions
Output Pulse Amplitude:						Differential Line Interface mode
E1, 75 Ω load		2.14	2.37	2.60	V	
E1, 120 Ω load		2.7	3.0	3.3	V	
Zero (Space) Level:						Differential Line Interface mode
E1, 75 Ω load		-0.237		+0.237	V	
E1, 120 Ω load		-0.3		0.3	V	
Transmit Amplitude Variation with Supply		-1		+1	%	
Output Pulse Width at 50% of Nominal Amplitude		232	244	256	ns	
Ratio of the Amplitudes of Positive and Negative Pulses at the Center of the Pulse Interval (G.703)		0.95		1.05		
Ratio of the Width of Positive and Negative Pulses at the Center of the Pulse Interval (G.703)		0.95		1.05		
Transmit Analog LOS Level (TALOS) (Differential line interface)	TALOS[1:0]				V <sub>p</sub>	Measured on the TTIP and TRING pins.
	00		1.2			
	01 (default)		0.9			
	10		0.6			
	11		0.4			
	TALOS hysteresis		0.08			
Transmit Analog LOS Level (TALOS) (Single Ended line interface)	TALOS[1:0]				V <sub>p</sub>	Measured on the TTIP pin.
	00		0.61			
	01 (default)		0.48			
	10		0.32			
	11		0.24			
	TALOS hysteresis		0.04			
Transmit Return Loss (G.703):						Internal Impedance Matching
51 KHz ~ 102 KHz		8			dB	
102 KHz ~ 2.048 MHz		14			dB	
2.048 MHz ~ 3.072 MHz		10			dB	
Intrinsic Transmit Jitter 20 Hz ~ 100 KHz				0.050	U.I.	TCLK is jitter free
Transmit Path Delay:						JA is disabled
Single Rail			8.5		U.I.	
Dual Rail NRZ			4.5		U.I.	
Dual Rail RZ			4.4		U.I.	
Line Short Circuit Current			100		mAp	Measured on pin

8.8 TRANSMITTER AND RECEIVER TIMING CHARACTERISTICS

Symbol	Parameter	Min	Typ.	Max	Unit
	MCLK Frequency: E1		2.048 X n (n = 1 ~ 8)		MHz
	MCLK Tolerance	-100		100	ppm
	MCLK Duty Cycle	30		70	%
Transmit Path					
	TCLK Frequency: E1		2.048		MHz
	TCLK Tolerance	-50		+50	ppm
	TCLK Duty Cycle	10		90	%
t1	Transmit Data Setup Time	40			ns
t2	Transmit Data Hold Time	40			ns
	Delay Time of OE low to Driver High-Z			1	μs
Receive Path					
	Clock Recovery Capture Range <sup>1</sup> : E1		+80 / -80		ppm
	RCLK Duty Cycle <sup>2</sup>	40	50	60	%
t4	RCLK Pulse Width <sup>2</sup> : E1	457	488	519	ns
t5	RCLK Pulse Width Low Time: E1	203	244	285	ns
t6	RCLK Pulse Width High Time: E1	203	244	285	ns
	Rise/Fall Time <sup>3</sup>	20			ns
t7	Receive Data Setup Time: E1	200	244		ns
t8	Receive Data Hold Time: E1	200	244		ns

**Note:**  
 1. Relative to nominal frequency, MCLK = +100 or -100 ppm.  
 2. RCLK duty cycle width will vary depending on extent of the received pulse jitter displacement. Maximum and minimum RCLK duty cycles are for worst case jitter conditions (0.2 UI displacement for E1 per ITU G.823).  
 3. For all digital outputs. C<sub>load</sub> = 15 pF.

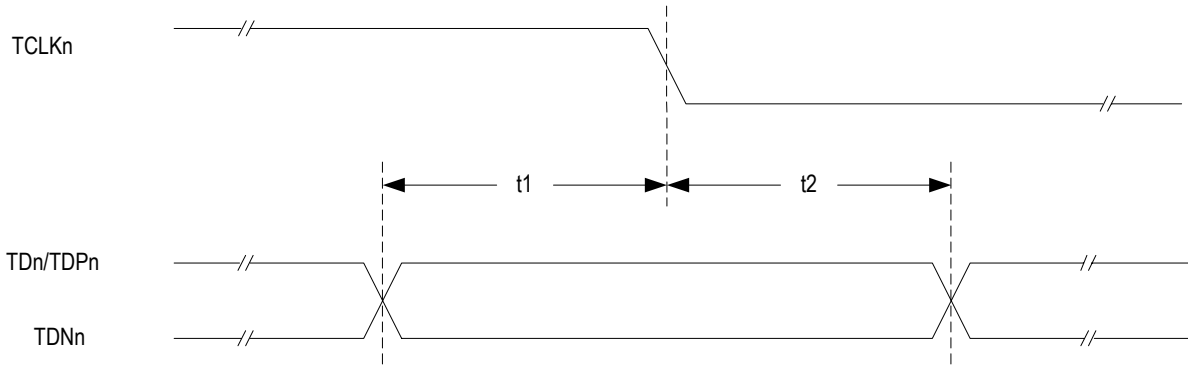


Figure-36 Transmit Clock Timing Diagram

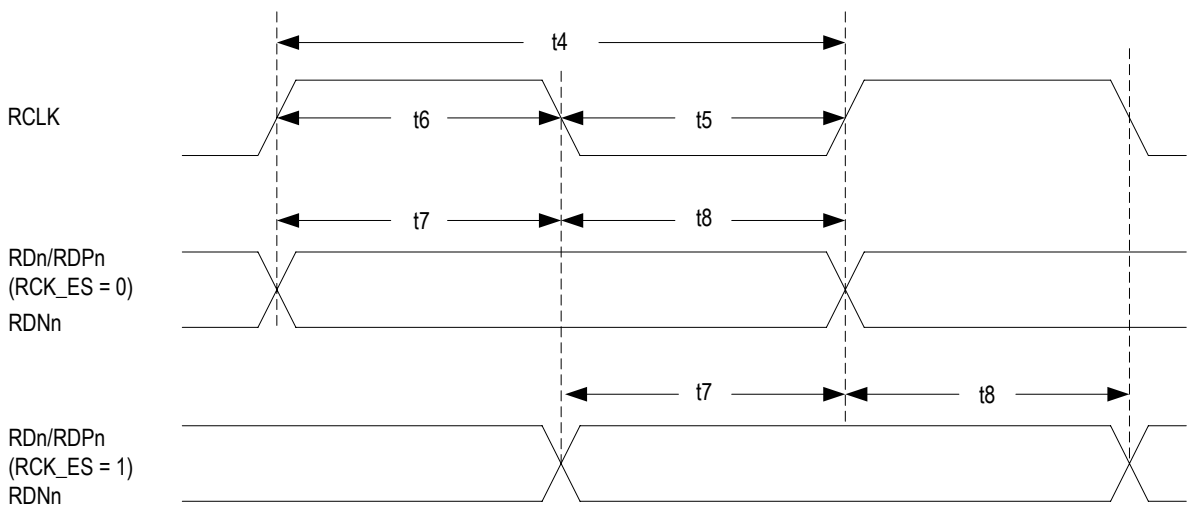


Figure-37 Receive Clock Timing Diagram



8.9 CLKE1 TIMING CHARACTERISTICS

Symbol	Parameter	Min	Typ.	Max	Unit
CLKE1 outputs 2.048 MHz clock					
t1	CLKE1 Pulse Width		488		ns
t2	CLKE1 Pulse Width High Time	232	244	256	ns
t3	CLKE1 Pulse Width Low Time	232	244	256	ns
t4	LLOS Data Setup Time	217	244	271	ns
t5	LLOS Data Hold Time	217	244	271	ns
CLKE1 outputs 8kHz clock					
t1	CLKE1 Pulse Width		125		μs
t2	CLKE1 Pulse Width High Time	62.4	62.5	62.6	μs
t3	CLKE1 Pulse Width Low Time	62.4	62.5	62.6	μs
t4	LLOS Data Setup Time	62.38	62.5	62.62	μs
t5	LLOS Data Hold Time	62.38	62.5	62.62	μs

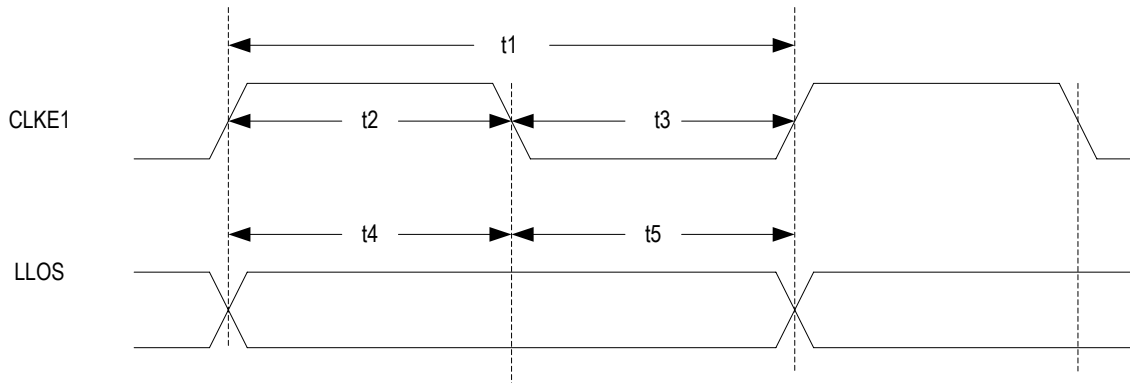


Figure-38 CLKE1 Clock Timing Diagram

8.10 JITTER ATTENUATION CHARACTERISTICS

Parameter	Min	Typ.	Max	Unit
Jitter Transfer Function Corner (-3 dB) Frequency: E1, 32/64/128-bit FIFO JA_BW = 0 JA_BW = 1		6.63 0.87		Hz Hz
Jitter Attenuator: E1 (G.736) @ 3 Hz @ 40 Hz @ 400 Hz @ 100 KHz	-0.5 -0.5 +19.5 +19.5			dB dB dB dB
Jitter Attenuator Latency Delay: 32-bit FIFO 64-bit FIFO 128-bit FIFO		16 32 64		U.I. U.I. U.I.
Input Jitter Tolerance before FIFO Overflow or Underflow: 32-bit FIFO 64-bit FIFO 128-bit FIFO		28 56 120		U.I. U.I. U.I.

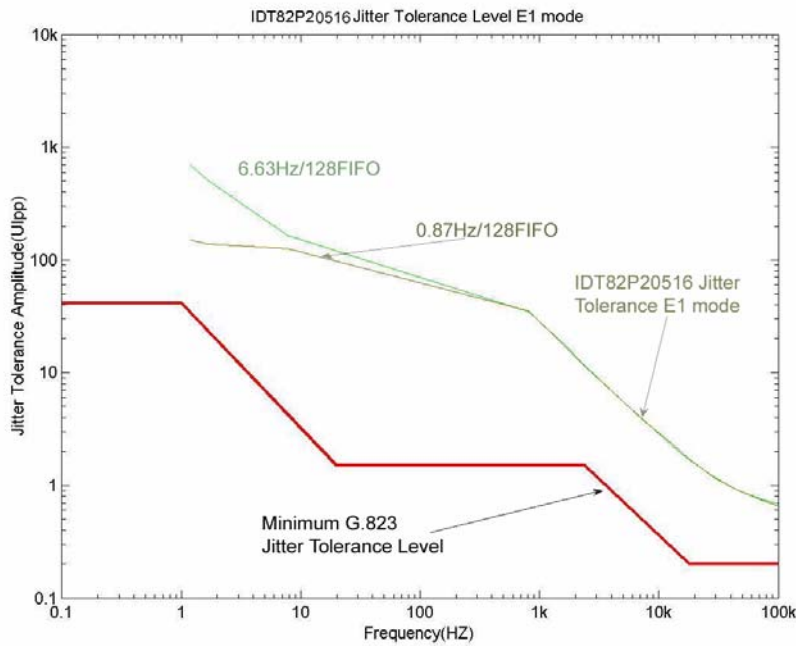


Figure-39 E1 Jitter Tolerance Performance

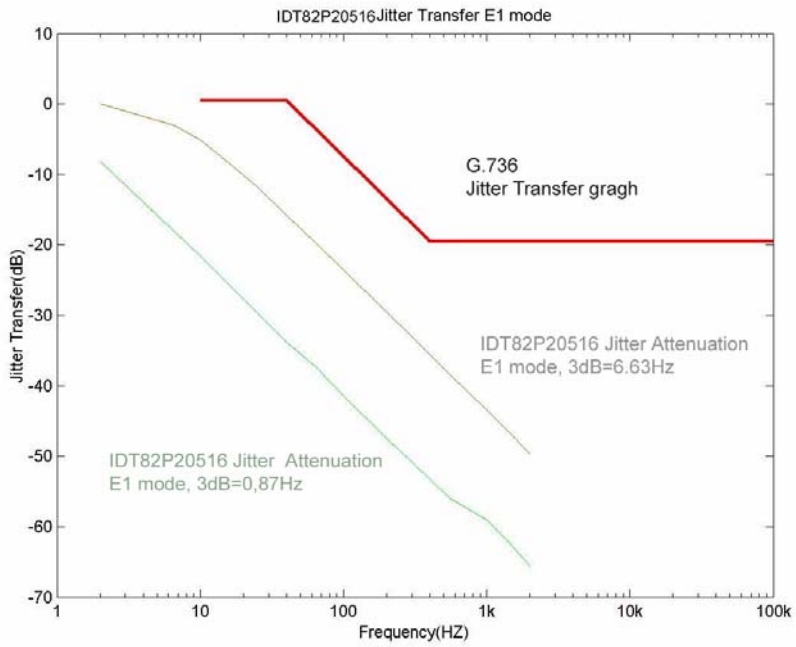


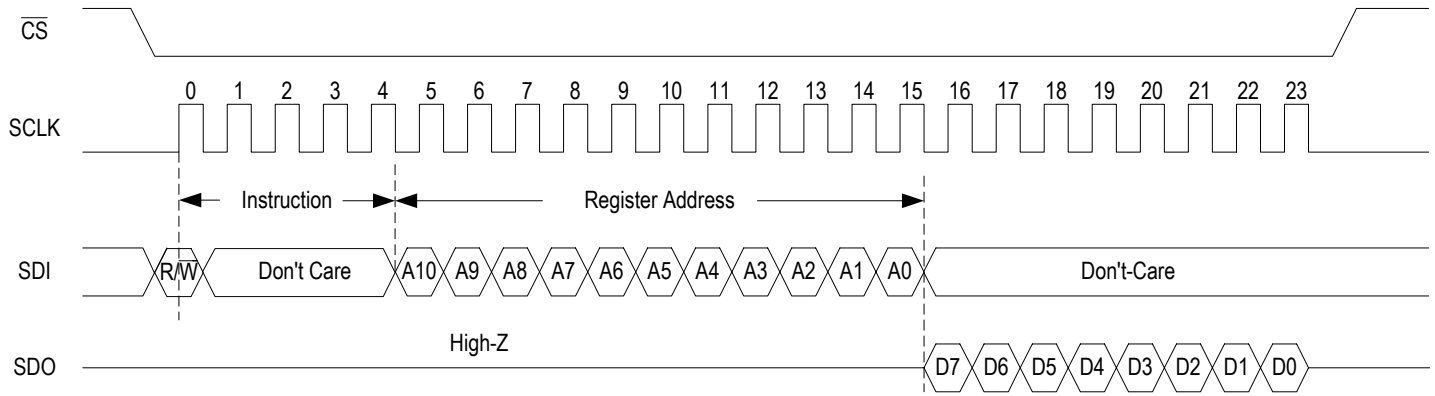
Figure-40 E1 Jitter Transfer Performance

**8.11 MICROPROCESSOR INTERFACE TIMING**

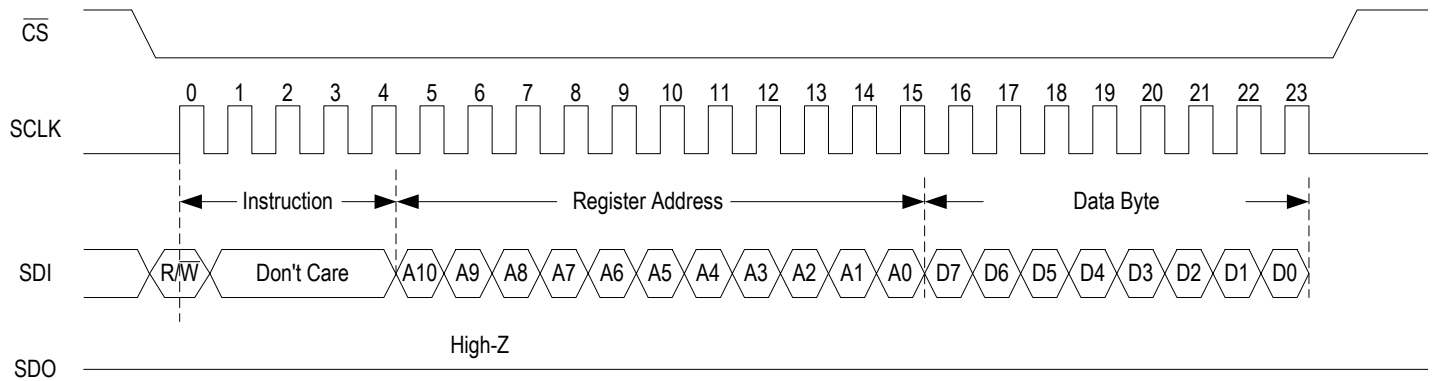
**8.11.1 SERIAL MICROPROCESSOR INTERFACE**

A falling transition on  $\overline{CS}$  indicates the start of a read/write operation, and a rising transition indicates the end of the operation. After  $\overline{CS}$  is set to low, a 5-bit instruction on SDI is input to the device on the rising edge of SCLK. If the MSB is '1', it is a read operation. If the MSB is '0', it is a

write operation. Following the instruction, an 11-bit address is clocked in on SDI to specify the register. If the device is in a read operation, the data read from the specified register is output on SDO on the falling edge of SCLK (refer to Figure-41). If the device is in a write operation, the data written to the specified register is input on SDI following the address byte (refer to Figure-42).



**Figure-41 Read Operation in Serial Microprocessor Interface**



**Figure-42 Write Operation in Serial Microprocessor Interface**

Symbol	Description	Min.	Max.	Units
$f_{OP}$	SCLK Frequency		2.0	MHz
$t_{CSH}$	Minimum $\overline{CS}$ High Time	100		ns
$t_{CSS}$	$\overline{CS}$ Setup Time	50		ns
$t_{CSD}$	$\overline{CS}$ Hold Time	100		ns
$t_{CLD}$	Clock Disable Time	50		ns
$t_{CLH}$	Clock High Time	205		ns
$t_{CLL}$	Clock Low Time	205		ns
$t_{DIS}$	Data Setup Time	50		ns
$t_{DIH}$	Data Hold Time	150		ns
$t_{PD}$	Output Delay		150	ns
$t_{DF}$	Output Disable Time		50	ns

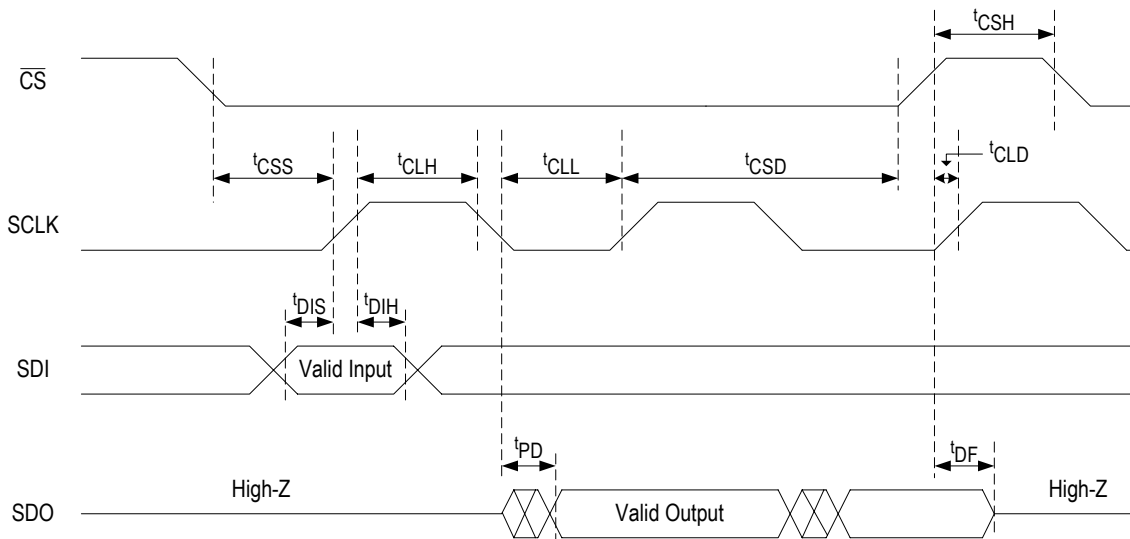


Figure-43 Timing Diagram

8.12 JTAG TIMING CHARACTERISTICS

Symbol	Parameter	Min	Typ.	Max	Unit
t1	TCK Period	100			ns
t2	TMS to TCK Setup Time; TDI to TCK Setup Time	25			ns
t3	TCK to TMS Hold Time; TCK to TDI Hold Time	25			ns
t4	TCK to TDO Delay Time			50	ns

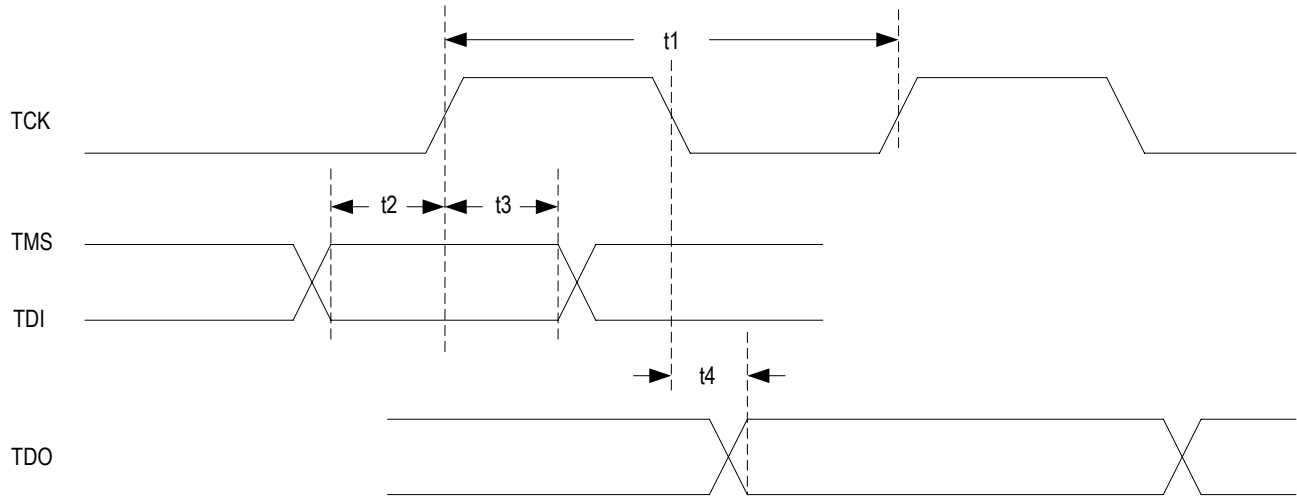


Figure-44 JTAG Timing

AIS	—	Alarm Indication Signal
AMI	—	Alternate Mark Inversion
ARB	—	Arbitrary Pattern
B8ZS	—	Binary 8 Zero Substitution
BPV	—	Bipolar Violation
CF	—	Corner Frequency
CV	—	Code Violation
DPLL	—	Digital Phase Locked Loop
EXZ	—	Excessive Zeroes
FIFO	—	First In First Out
HDB3	—	High Density Bipolar 3
HPS	—	Hitless Protection Switching
IB	—	Inband Loopback
LAIS	—	Line Alarm Indication Signal
LBPV	—	Line Bipolar Violation
LEXZ	—	Line Excessive Zeroes
LLOS	—	Line Loss of Signal
LOS	—	Loss Of Signal
NRZ	—	Non-Return to Zero
PBX	—	Private Branch Exchange
PRBS	—	Pseudo Random Bit Sequence
QRSS	—	Quasi-Random Signal Source
RJA	—	Receive Jitter Attenuator
RZ	—	Return to Zero
SAIS	—	System Alarm Indication Signal
SBPV	—	System Bipolar Violation
SDH	—	Synchronous Digital Hierarchy

SEXZ	—	System Excessive Zeroes
SLOS	—	System LOS
SONET	—	Synchronous Optical Network
TEPBGA	—	Thermally Enhanced Plastic Ball Grid Array
TJA	—	Transmit Jitter Attenuator
TLOS	—	Transmit Loss of Signal
TOC	—	Transmit Over Current

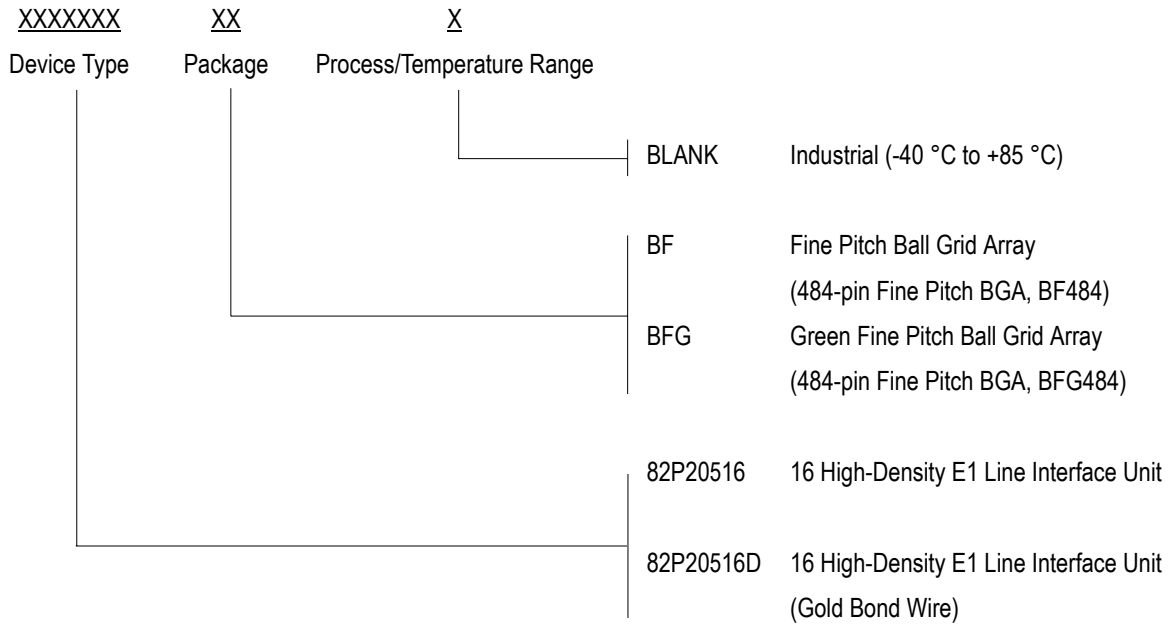




<b>A</b>		<b>I</b>	
Alarm Indication Signal (AIS) .....	35	impedance matching	
<b>B</b>		receive	
Bipolar Violation (BPV) .....	31	External Impedance Matching .....	19
<b>C</b>		Fully Internal Impedance Matching .....	19
cable		Partially Internal Impedance Matching .....	19
coaxial cable .....	19, 27	transmit	
twisted pair cable .....	19, 27	External Impedance Matching .....	27
clock input		Internal Impedance Matching .....	27
MCLK .....	46	Interrupt .....	47
XCLK .....	46	<b>J</b>	
clock output		JA-Limit .....	30
CLKT1/CLKE1 .....	45	Jitter Measurement (JM) .....	44
Code Violation (CV) .....	31	JTAG .....	17, 92
common control .....	16	<b>L</b>	
Corner Frequency (CF) .....	30	line interface .....	12, 19, 27
<b>D</b>		receive	
decoder .....	22	Differential .....	19
<b>E</b>		transmit	
encoder .....	24	Differential .....	27
error counter .....	38	line monitor .....	21
Excessive Zeroes (EXZ) .....	31	loopback	
<b>F</b>		Analog Loopback .....	40
free running .....	45	Digital Loopback .....	42
<b>G</b>		Remote Loopback .....	41
G.772 Monitoring .....	43	Loss of Signal (LOS) .....	32
<b>H</b>		Line LOS (LLOS) .....	32
heatsink .....	94	System LOS (SLOS) .....	33
high impedance .....	12, 19, 23, 27, 29	Transmit LOS (TLOS) .....	34
Hitless Protection Switch (HPS) .....	19	<b>M</b>	
hitless switch .....	19	microprocessor interface .....	17, 50
hot-swap .....	19	monitoring	
hot-switchover .....	19	G.772 monitoring .....	43
<b>I</b>		line monitor .....	21
<b>J</b>		<b>P</b>	
<b>K</b>		pattern	
<b>L</b>		ARB .....	36, 37
<b>M</b>		Inband Loopback (IB) .....	36, 38
<b>N</b>		PRBS .....	36, 37
<b>O</b>		<b>Q</b>	
<b>P</b>		<b>R</b>	
<b>Q</b>		<b>S</b>	
<b>R</b>		<b>T</b>	
<b>S</b>		<b>U</b>	
<b>T</b>		<b>V</b>	
<b>U</b>		<b>W</b>	
<b>V</b>		<b>X</b>	
<b>W</b>		<b>Y</b>	
<b>X</b>		<b>Z</b>	

power down .....	23, 29	system interface .....	13, 22, 23
receiver .....	23	receive	
transmitter .....	29	Dual Rail NRZ Format .....	22
Protected Non-Intrusive Monitoring .....	21	Dual Rail RZ Format .....	22
<b>R</b>		Dual Rail Sliced .....	22
receive sensitivity .....	21	Single Rail NRZ Format .....	22
reset		transmit	
global software reset .....	50	Dual Rail NRZ Format .....	23
hardware reset .....	50	Dual Rail RZ Format .....	23
power-on reset .....	50	Single Rail NRZ Format .....	23
Rx clock & data recovery .....	22	<b>T</b>	
<b>S</b>		T1 / E1 / J1 mode selection .....	19
slicer .....	22	Transmit Over Current (TOC) .....	27
		<b>W</b>	
		waveform template .....	24

**ORDERING INFORMATION**



## IMPORTANT NOTICE AND DISCLAIMER

RENESAS ELECTRONICS CORPORATION AND ITS SUBSIDIARIES (“RENESAS”) PROVIDES TECHNICAL SPECIFICATIONS AND RELIABILITY DATA (INCLUDING DATASHEETS), DESIGN RESOURCES (INCLUDING REFERENCE DESIGNS), APPLICATION OR OTHER DESIGN ADVICE, WEB TOOLS, SAFETY INFORMATION, AND OTHER RESOURCES “AS IS” AND WITH ALL FAULTS, AND DISCLAIMS ALL WARRANTIES, EXPRESS OR IMPLIED, INCLUDING, WITHOUT LIMITATION, ANY IMPLIED WARRANTIES OF MERCHANTABILITY, FITNESS FOR A PARTICULAR PURPOSE, OR NON-INFRINGEMENT OF THIRD-PARTY INTELLECTUAL PROPERTY RIGHTS.

These resources are intended for developers who are designing with Renesas products. You are solely responsible for (1) selecting the appropriate products for your application, (2) designing, validating, and testing your application, and (3) ensuring your application meets applicable standards, and any other safety, security, or other requirements. These resources are subject to change without notice. Renesas grants you permission to use these resources only to develop an application that uses Renesas products. Other reproduction or use of these resources is strictly prohibited. No license is granted to any other Renesas intellectual property or to any third-party intellectual property. Renesas disclaims responsibility for, and you will fully indemnify Renesas and its representatives against, any claims, damages, costs, losses, or liabilities arising from your use of these resources. Renesas' products are provided only subject to Renesas' Terms and Conditions of Sale or other applicable terms agreed to in writing. No use of any Renesas resources expands or otherwise alters any applicable warranties or warranty disclaimers for these products.

(Disclaimer Rev.1.01 Jan 2024)

### Corporate Headquarters

TOYOSU FORESIA, 3-2-24 Toyosu,  
Koto-ku, Tokyo 135-0061, Japan  
[www.renesas.com](http://www.renesas.com)

### Trademarks

Renesas and the Renesas logo are trademarks of Renesas Electronics Corporation. All trademarks and registered trademarks are the property of their respective owners.

### Contact Information

For further information on a product, technology, the most up-to-date version of a document, or your nearest sales office, please visit [www.renesas.com/contact-us/](http://www.renesas.com/contact-us/).