

General Description

The 85408 is a low skew, high performance 1-to-8 Differential-to-LVDS Clock Distribution Chip. The 85408 CLK, nCLK pair can accept most differential input levels and translates them to 3.3V LVDS output levels. Utilizing Low Voltage Differential Signaling (LVDS), the 85408 provides a low power, low noise, low skew, point-to-point solution for distributing LVDS clock signals.

Guaranteed output and part-to-part skew specifications make the 85408 ideal for those applications demanding well defined performance and repeatability.

Features

- Eight differential LVDS output pairs
- CLK/nCLK can accept the following differential input levels: LVPECL, LVDS, LVHSTL, HCSSL, SSTL
- Maximum output frequency: 700MHz
- Translates any differential input signal (LVPECL, LVHSTL, SSTL, HCSSL) to LVDS levels without external bias networks
- Translates any single-ended input signal to LVDS with resistor bias on nCLK input
- Output skew: 50ps (maximum)
- Part-to-part skew: 550ps (maximum)
- Propagation delay: 2.4ns (maximum)
- 3.3V operating supply
- 0°C to 70°C ambient operating temperature
- Available in lead-free (RoHS 6) package

Block Diagram

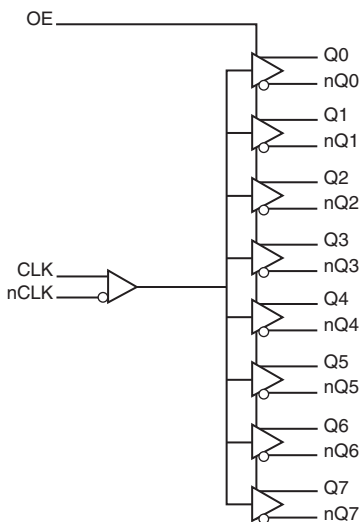

Pin Assignment

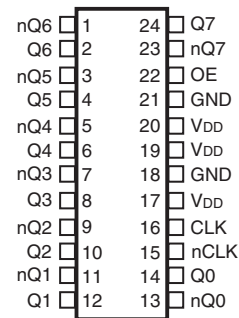

85408
24-Lead TSSOP
4.4mm x 7.8mm x 0.925mm package body
G Package
Top View

Table 1. Pin Descriptions

| Number | Name | Type | | Description |
|------------|-----------------|--------|----------|---|
| 1, 2 | nQ6, Q6 | Output | | Differential output pair. LVDS interface levels. |
| 3, 4 | nQ5, Q5 | Output | | Differential output pair. LVDS interface levels. |
| 5, 6 | nQ4, Q4 | Output | | Differential output pair. LVDS interface levels. |
| 7, 8 | nQ3, Q3 | Output | | Differential output pair. LVDS interface levels. |
| 9, 10 | nQ2, Q2 | Output | | Differential output pair. LVDS interface levels. |
| 11, 12 | nQ1, Q1 | Output | | Differential output pair. LVDS interface levels. |
| 13, 14 | nQ0, Q0 | Output | | Differential output pair. LVDS interface levels. |
| 15 | nCLK | Input | Pullup | Inverting differential clock input. |
| 16 | CLK | Input | Pulldown | Non-inverting differential clock input. |
| 17, 19, 20 | V _{DD} | Power | | Positive supply pins. |
| 18, 21 | GND | Power | | Power supply ground. |
| 22 | OE | Input | Pullup | Output enable. Controls the enabling and disabling of outputs Qx, nQx. When HIGH, the outputs are enabled. When LOW, the outputs are in High-Impedance. LVCMOS / LVTTTL interface levels. |
| 23, 24 | nQ7, Q7 | Output | | Differential output pair. LVDS interface levels. |

NOTE: *Pullup* and *Pulldown* refer to internal input resistors. See Table 2, *Pin Characteristics*, for typical values.

Table 2. Pin Characteristics

| Symbol | Parameter | Test Conditions | Minimum | Typical | Maximum | Units |
|-----------------------|--|-----------------|---------|---------|---------|-------|
| C _{IN} | Input Capacitance | | | 4 | | pF |
| C _{PD} | Power Dissipation Capacitance (per output) | | | 4 | | pF |
| R _{PULLUP} | Input Pullup Resistor | | | 51 | | kΩ |
| R _{PULLDOWN} | Input Pulldown Resistor | | | 51 | | kΩ |

Function Tables

Table 3A. Output Enable Function Table

| Inputs | Outputs |
|--------|------------------|
| OE | Q[0:7], nQ[0:7] |
| 0 | High-Impedance |
| 1 | Active (default) |

Table 3B. Clock Input Function Table

| Inputs | | Outputs | | Input to Output Mode | Polarity |
|----------------|----------------|---------|---------|------------------------------|---------------|
| CLK | nCLK | Q[0:7] | nQ[0:7] | | |
| 0 | 1 | LOW | HIGH | Differential to Differential | Non-Inverting |
| 1 | 0 | HIGH | LOW | Differential to Differential | Non-Inverting |
| 0 | Biased; NOTE 1 | LOW | HIGH | Single-Ended to Differential | Non-Inverting |
| 1 | Biased; NOTE 1 | HIGH | LOW | Single-Ended to Differential | Non-Inverting |
| Biased; NOTE 1 | 0 | HIGH | LOW | Single-Ended to Differential | Inverting |
| Biased; NOTE 1 | 1 | LOW | HIGH | Single-Ended to Differential | Inverting |

NOTE 1: Please refer to the Application Information section, *Wiring the Differential Input to Accept Single-Ended Levels*.

Absolute Maximum Ratings

NOTE: Stresses beyond those listed under *Absolute Maximum Ratings* may cause permanent damage to the device. These ratings are stress specifications only. Functional operation of product at these conditions or any conditions beyond those listed in the *DC Characteristics* or *AC Characteristics* is not implied. Exposure to absolute maximum rating conditions for extended periods may affect product reliability.

| Item | Rating |
|--|--------------------------|
| Supply Voltage, V_{DD} | 4.6V |
| Inputs, V_I | -0.5V to $V_{DD} + 0.5V$ |
| Outputs, I_O (LVDS) Continuous Current Surge Current | 10mA 15mA |
| Package Thermal Impedance, θ_{JA} | 70°C/W (0 mps) |
| Storage Temperature, T_{STG} | -65°C to 150°C |

DC Electrical Characteristics

Table 4A. LVDS Power Supply DC Characteristics, $V_{DD} = 3.3V \pm 5\%$, $T_A = 0^\circ C$ to $70^\circ C$

| Symbol | Parameter | Test Conditions | Minimum | Typical | Maximum | Units |
|----------|-------------------------|-----------------|---------|---------|---------|-------|
| V_{DD} | Positive Supply Voltage | | 3.135 | 3.3 | 3.465 | V |
| I_{DD} | Power Supply Current | | | | 90 | mA |

Table 4B. LVCMOS/LVTTL DC Characteristics, $V_{DD} = 3.3V \pm 5\%$, $T_A = 0^\circ C$ to $70^\circ C$

| Symbol | Parameter | Test Conditions | Minimum | Typical | Maximum | Units |
|----------|--------------------|--------------------------------|---------|---------|----------------|---------|
| V_{IH} | Input High Voltage | | 2 | | $V_{DD} + 0.3$ | V |
| V_{IL} | Input Low Voltage | | -0.3 | | 0.8 | V |
| I_{IH} | Input High Current | $V_{DD} = V_{IN} = 3.465V$ | | | 5 | μA |
| I_{IL} | Input Low Current | $V_{DD} = 3.465V, V_{IN} = 0V$ | -150 | | | μA |

Table 4C. Differential DC Characteristics, $V_{DD} = 3.3V \pm 5\%$, $T_A = 0^\circ C$ to $70^\circ C$

| Symbol | Parameter | Test Conditions | Minimum | Typical | Maximum | Units |
|-----------|--------------------------------------|-----------------|--------------------------------|---------|-----------------|---------|
| I_{IH} | Input High Current | CLK | $V_{DD} = V_{IN} = 3.465V$ | | 150 | μA |
| | | nCLK | $V_{DD} = V_{IN} = 3.465V$ | | 5 | |
| I_{IL} | Input Low Current | CLK | $V_{DD} = 3.465V, V_{IN} = 0V$ | -5 | | μA |
| | | nCLK | $V_{DD} = 3.465V, V_{IN} = 0V$ | -150 | | μA |
| V_{PP} | Peak-to-Peak Voltage; NOTE 1 | | 0.15 | | 1.3 | V |
| V_{CMR} | Common Mode Input Voltage; NOTE 1, 2 | | GND + 0.5 | | $V_{DD} - 0.85$ | V |

NOTE 1: V_{IL} should not be less than -0.3V.

NOTE 2: Common mode input voltage is defined as V_{IH} .

Table 4D. LVDS DC Characteristics, $V_{DD} = 3.3V \pm 5\%$, $T_A = 0^\circ C$ to $70^\circ C$

| Symbol | Parameter | Test Conditions | Minimum | Typical | Maximum | Units |
|------------------|---|-------------------|---------|---------|---------|---------|
| V_{OD} | Differential Output Voltage | $R_L = 100\Omega$ | 250 | 400 | 600 | mV |
| ΔV_{OD} | V_{OD} Magnitude Change | $R_L = 100\Omega$ | | | 50 | mV |
| V_{OS} | Offset Voltage | $R_L = 100\Omega$ | 1.125 | 1.4 | 1.6 | V |
| ΔV_{OS} | V_{OS} Magnitude Change | $R_L = 100\Omega$ | | | 50 | mV |
| I_{OZ} | High Impedance Leakage | | -10 | | +10 | μA |
| I_{OFF} | Power Off Leakage | | -1 | | +1 | μA |
| I_{OSD} | Differential Output Short Circuit Current | | | | -5.5 | mA |
| I_{OS}/I_{OSB} | Output Short Circuit Current | | | | -12 | mA |

Table 5. AC Characteristics, $V_{DD} = 3.3V \pm 5\%$, $T_A = 0^\circ C$ to $70^\circ C$

| Symbol | Parameter | Test Conditions | Minimum | Typical | Maximum | Units |
|--------------------|---|--|---------|---------|---------|-------|
| f_{MAX} | Output Frequency | | | | 700 | MHz |
| t_{PD} | Propagation Delay; NOTE 1 | | 1.6 | | 2.4 | ns |
| t_{jit} | Buffer Additive Phase Jitter, RMS; refer to Additive Phase Jitter Section | 156.25MHz, Integration Range: (12kHz – 20MHz) | | 167 | | fs |
| $t_{sk(o)}$ | Output Skew; NOTE 2, 4 | | | | 50 | ps |
| $t_{sk(pp)}$ | Part-to-Part Skew; NOTE 3, 4 | | | | 550 | ps |
| t_R / t_F | Output Rise/Fall Time | 20% to 80% | 50 | | 600 | ps |
| odc | Output Duty Cycle | | 45 | | 55 | % |
| t_{PZL}, t_{PZH} | Output Enable Time; NOTE 5 | | | | 5 | ns |
| t_{PLZ}, t_{PHZ} | Output Disable Time; NOTE 5 | | | | 5 | ns |

NOTE: Electrical parameters are guaranteed over the specified ambient operating temperature range, which is established when the device is mounted in a test socket with maintained transverse airflow greater than 500 lfm. The device will meet specifications after thermal equilibrium has been reached under these conditions.

NOTE: All parameters measured at $f \leq 622MHz$ unless noted otherwise.

NOTE 1: Measured from the differential input crossing point to the differential output crossing point.

NOTE 2: Defined as skew between outputs at the same supply voltage and with equal load conditions. Measured at the differential crossing point of the input to the differential output crossing point.

NOTE 3: Defined as skew between outputs on different devices operating at the same supply voltages and with equal load conditions. Using the same type of inputs on each device, the outputs are measured at the differential cross points.

NOTE 4: This parameter is defined in accordance with JEDEC Standard 65.

NOTE 5: These parameters are guaranteed by characterization. Not tested in production.

Additive Phase Jitter

The spectral purity in a band at a specific offset from the fundamental compared to the power of the fundamental is called the **dBc Phase Noise**. This value is normally expressed using a Phase noise plot and is most often the specified plot in many applications. Phase noise is defined as the ratio of the noise power present in a 1Hz band at a specified offset from the fundamental frequency to the power value of the fundamental. This ratio is expressed in decibels (dBm) or a ratio

of the power in the 1Hz band to the power in the fundamental. When the required offset is specified, the phase noise is called a **dBc** value, which simply means dBm at a specified offset from the fundamental. By investigating jitter in the frequency domain, we get a better understanding of its effects on the desired application over the entire time record of the signal. It is mathematically possible to calculate an expected bit error rate given a phase noise plot.

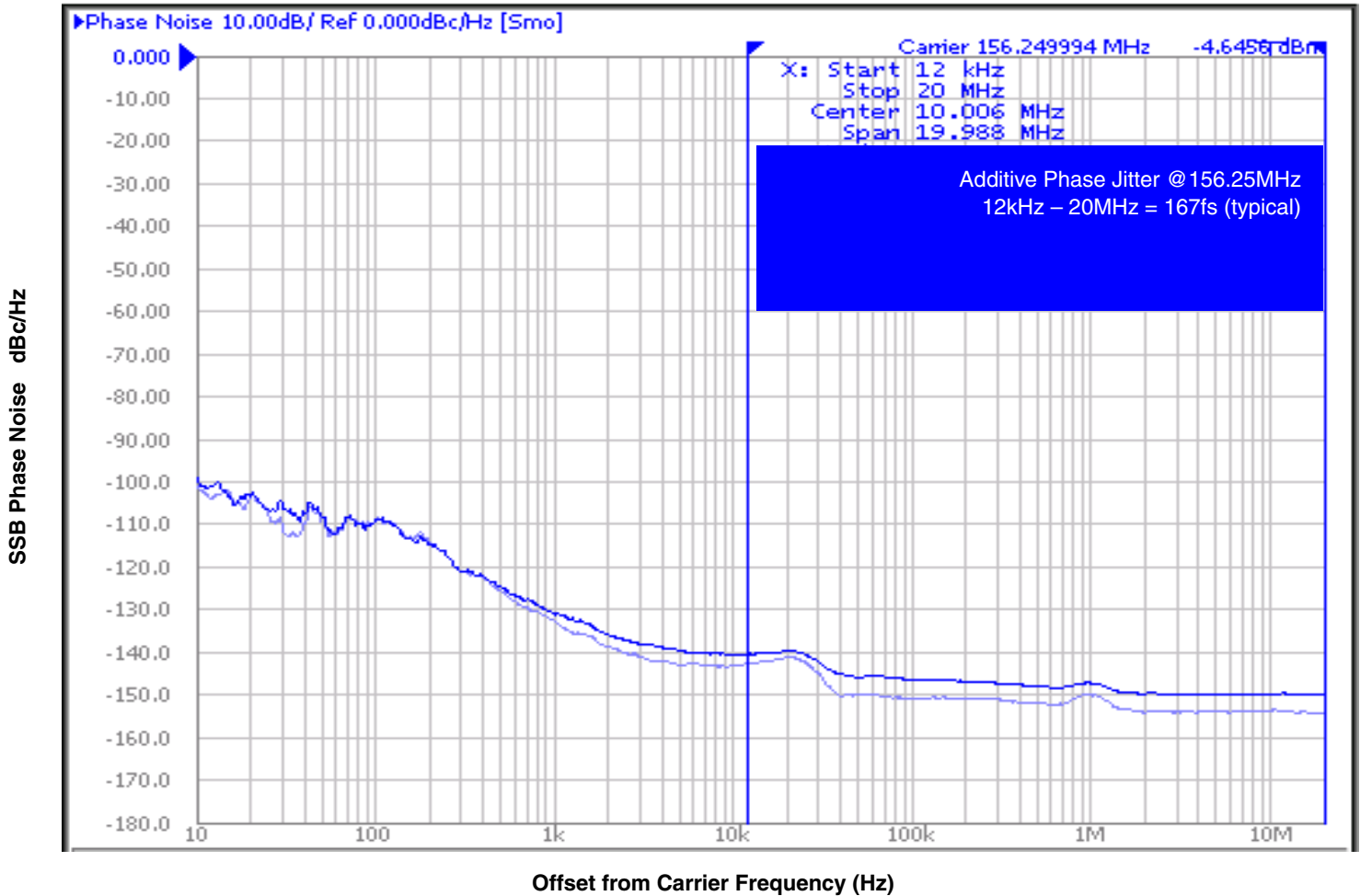

As with most timing specifications, phase noise measurements has issues relating to the limitations of the equipment. Often the noise floor of the equipment is higher than the noise floor of the device. This

is illustrated above. The device meets the noise floor of what is shown, but can actually be lower. The phase noise is dependent on the input source and measurement equipment.

Parameter Measurement Information

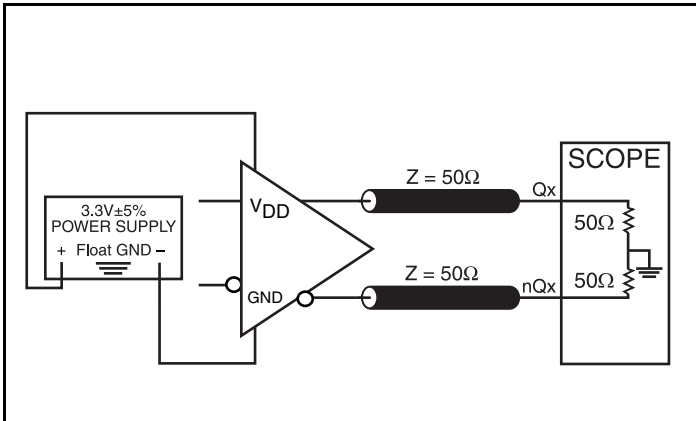

3.3V LVDS Output Load AC Test Circuit

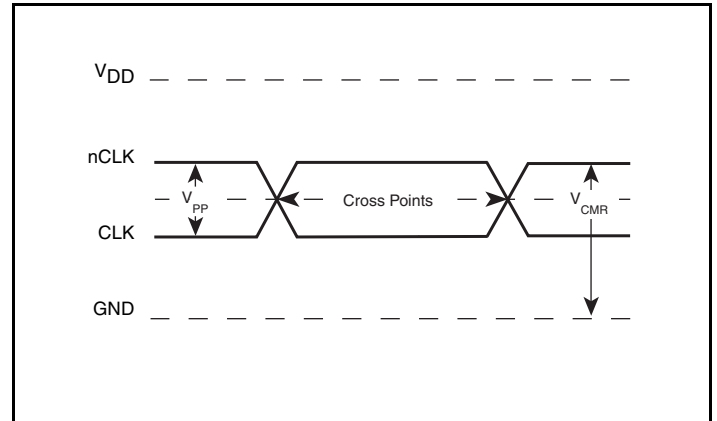

Differential Input Level

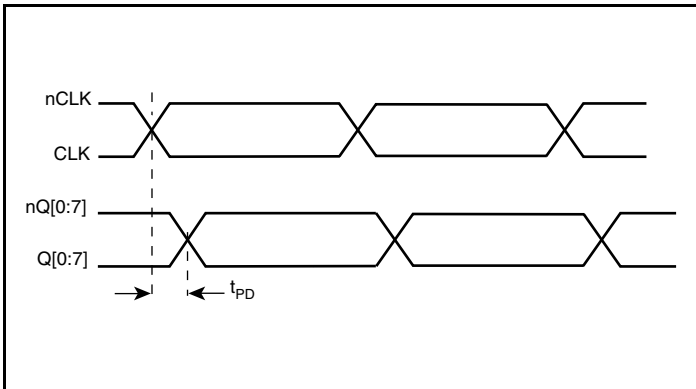

Propagation Delay

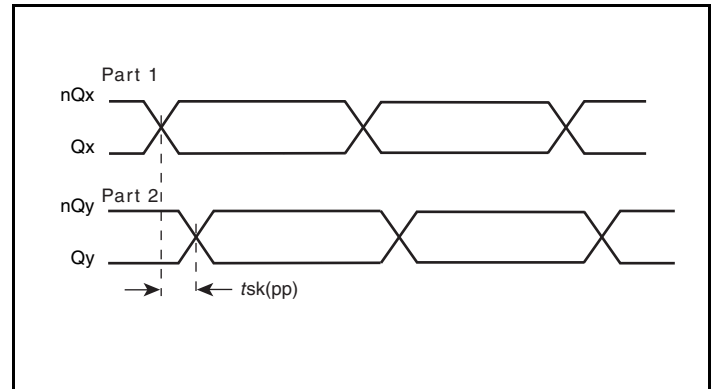

Part-to-Part Skew

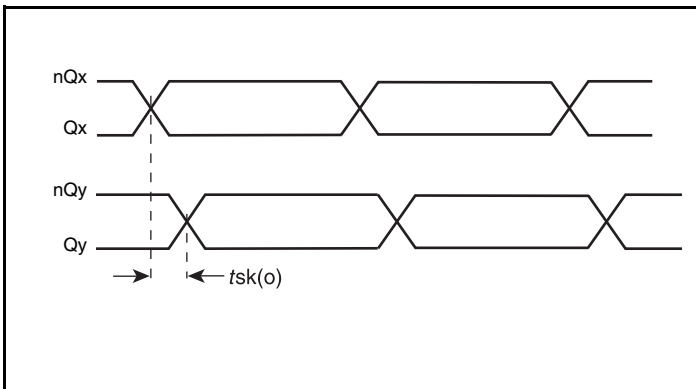

Output Skew

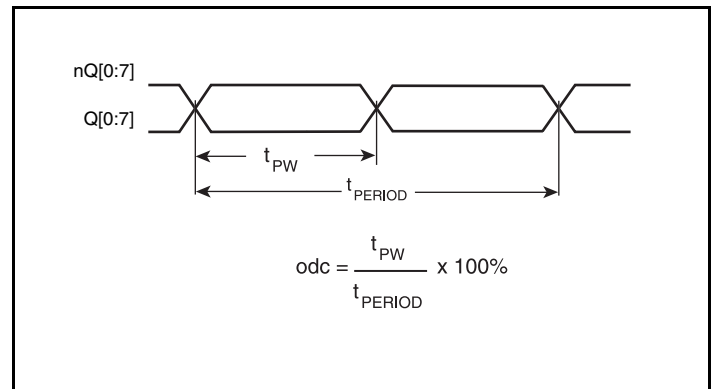

Output Duty Cycle/Pulse Width/Period

Parameter Measurement Information, continued

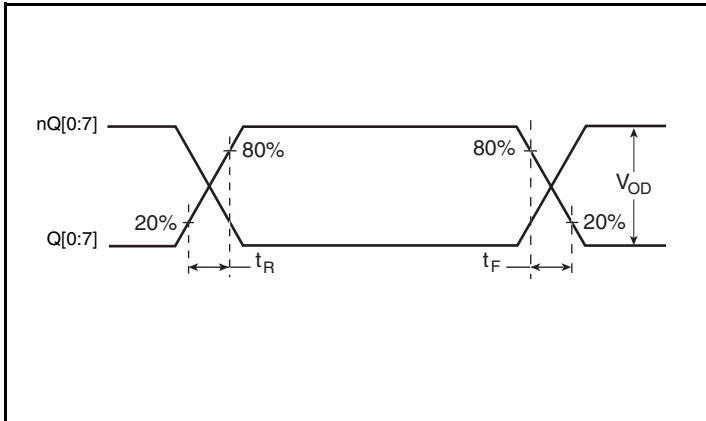

Output Rise/Fall Time

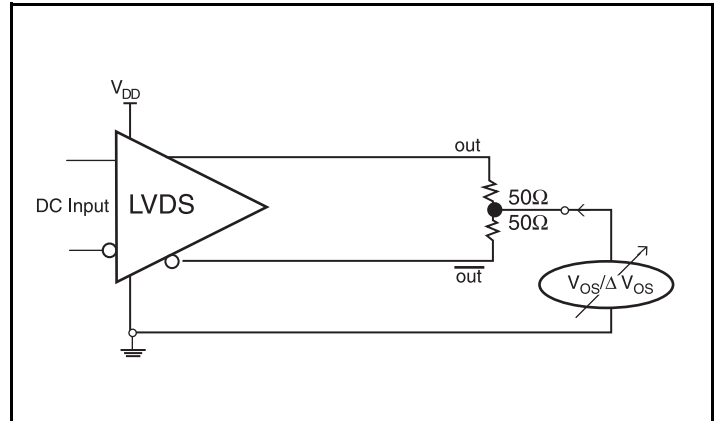

Offset Voltage Setup

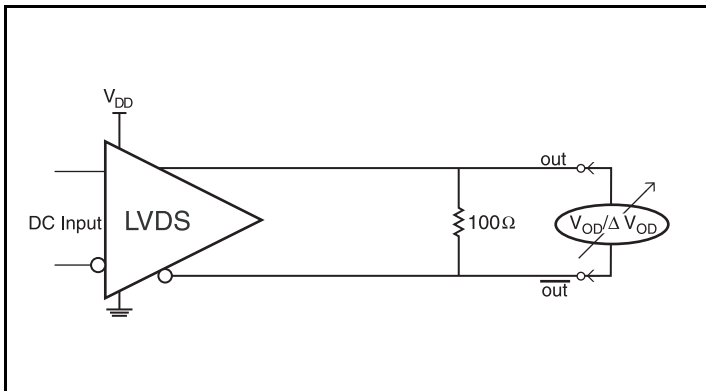

Differential Output Voltage Setup

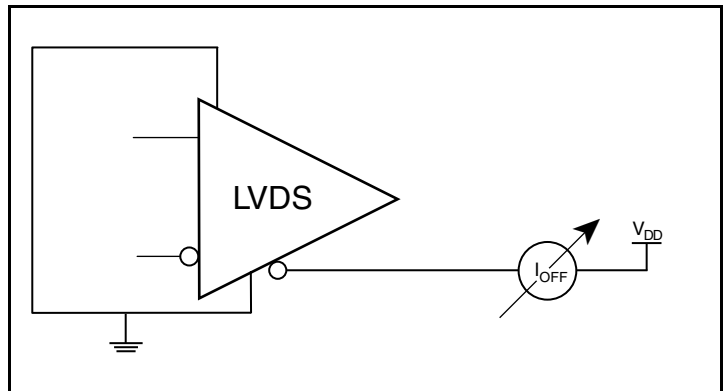

Power Off Leakage Setup

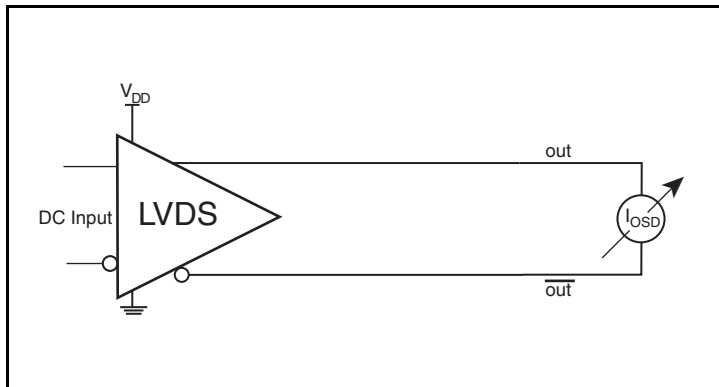

Differential Output Short Circuit Setup

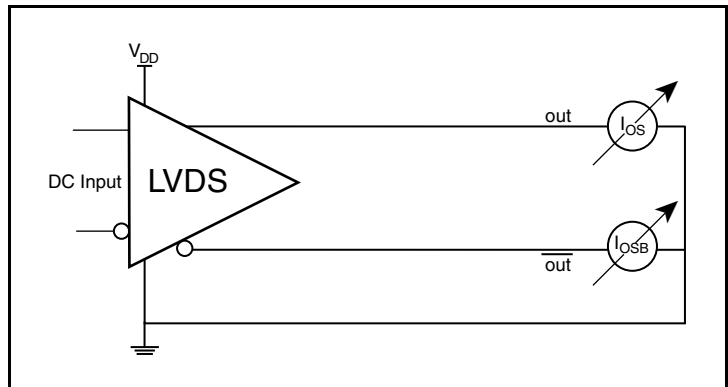

Output Short Circuit Current Setup

Application Information

Wiring the Differential Input to Accept Single-Ended Levels

Figure 1 shows how the differential input can be wired to accept single-ended levels. The reference voltage $V_{REF} = V_{DD}/2$ is generated by the bias resistors R1, R2 and C1. This bias circuit should be located as close as possible to the input pin. The ratio of R1 and R2 might need to be adjusted to position the V_{REF} in the center of the input voltage swing. For example, if the input clock swing is only 2.5V and $V_{DD} = 3.3V$, V_{REF} should be 1.25V and $R2/R1 = 0.609$.

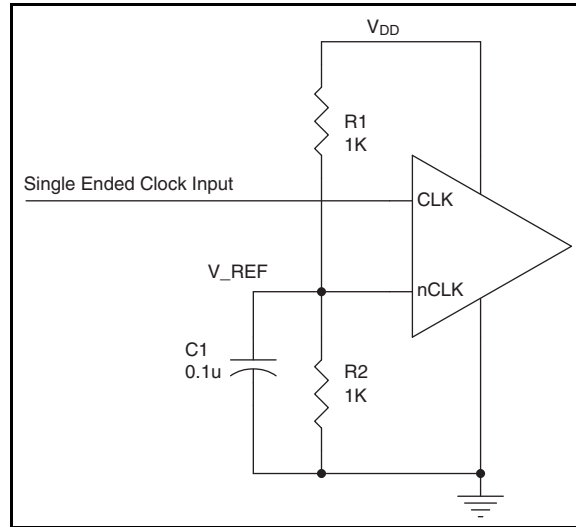

Figure 1. Single-Ended Signal Driving Differential Input

Recommendations for Unused Output Pins

Outputs:

LVDS Outputs

All unused LVDS output pairs can be either left floating or terminated with 100Ω across. If they are left floating, there should be no trace attached.

Differential Clock Input Interface

The CLK /nCLK accepts LVDS, LVPECL, LVHSTL, SSTL, HCSL and other differential signals. Both signals must meet the V_{PP} and V_{CMR} input requirements. Figures 2A to 2F show interface examples for the HiPerClockS CLK/nCLK input driven by the most common driver types. The input interfaces suggested here are examples only.

Please consult with the vendor of the driver component to confirm the driver termination requirements. For example, in Figure 2A, the input termination applies for IDT HiPerClockS open emitter LVHSTL drivers. If you are using an LVHSTL driver from another vendor, use their termination recommendation.

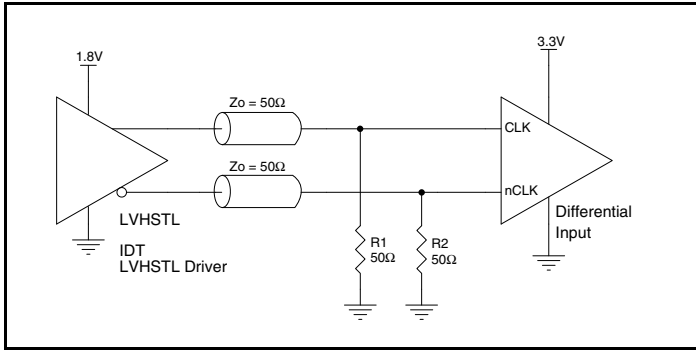

2A. HiPerClockS CLK/nCLK Input Driven by an IDT Open Emitter HiPerClockS LVHSTL Driver

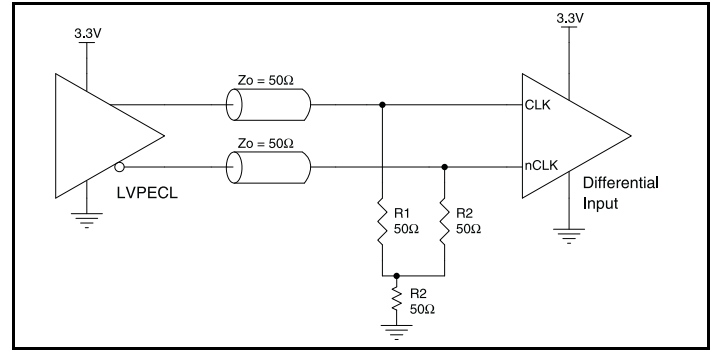

Figure 2B. HiPerClockS CLK/nCLK Input Driven by a 3.3V LVPECL Driver

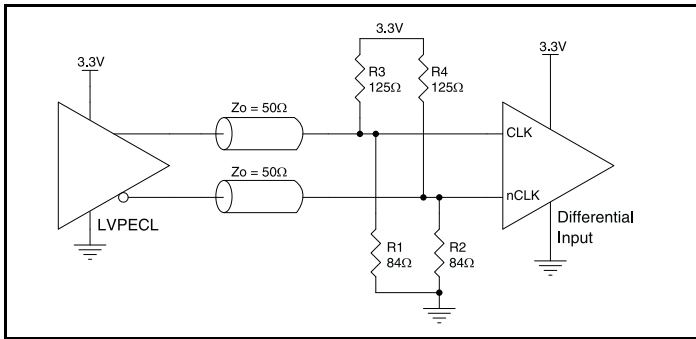

Figure 3C. HiPerClockS CLK/nCLK Input Driven by a 3.3V LVPECL Driver

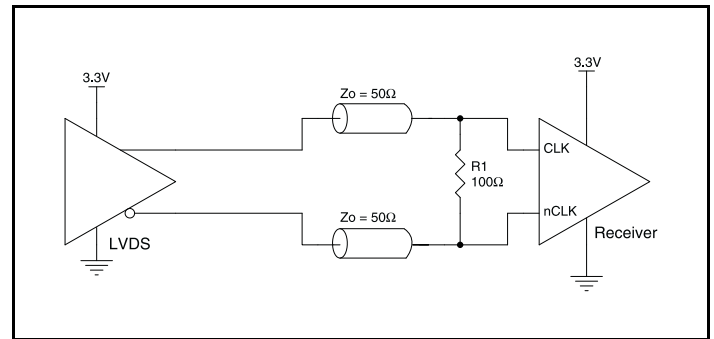

Figure 2D. HiPerClockS CLK/nCLK Input Driven by a 3.3V LVDS Driver

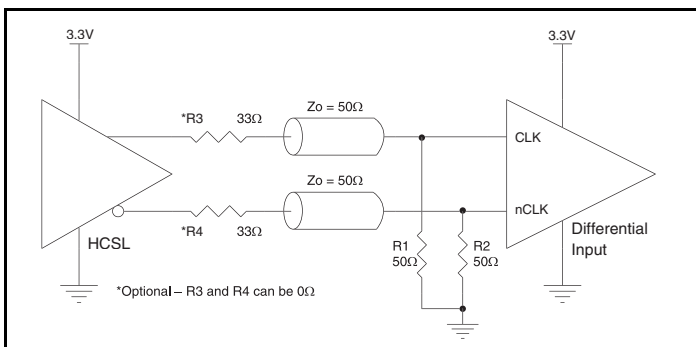

Figure 2E. HiPerClockS CLK/nCLK Input Driven by a 3.3V HCSL Driver

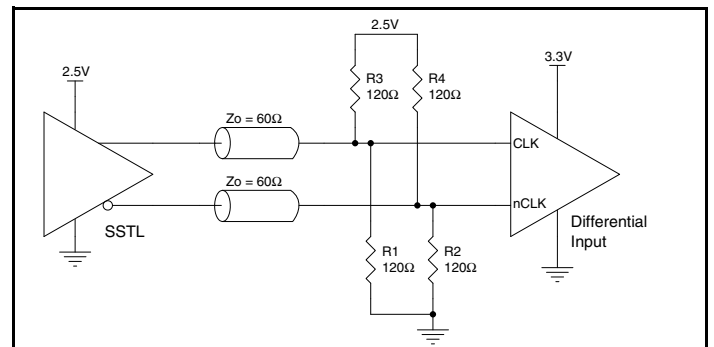

Figure 2F. HiPerClockS CLK/nCLK Input Driven by a 2.5V SSTL Driver

3.3V LVDS Driver Termination

A general LVDS interface is shown in *Figure 3*. In a 100Ω differential transmission line environment, LVDS drivers require a matched load termination of 100Ω across near the receiver input. For a multiple

LVDS outputs buffer, if only partial outputs are used, it is recommended to terminate the unused outputs.

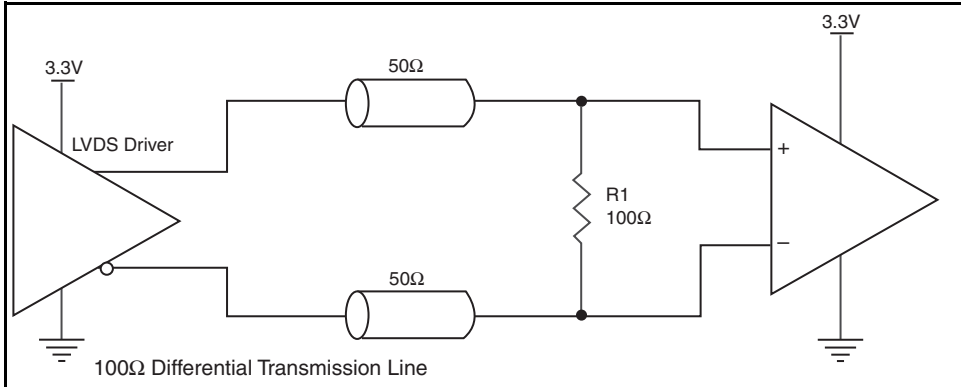

Figure 3. Typical LVDS Driver Termination

Power Considerations

This section provides information on power dissipation and junction temperature for the 85408. Equations and example calculations are also provided.

1. Power Dissipation.

The total power dissipation for the 85408 is the sum of the core power plus the analog power plus the power dissipated in the load(s). The following is the power dissipation for $V_{DD} = 3.3V + 5\% = 3.465V$, which gives worst case results.

- $\text{Power (core)}_{MAX} = V_{DD_MAX} * I_{DD_MAX} = 3.465V * 90mA = \mathbf{311.85mW}$

2. Junction Temperature.

Junction temperature, T_j , is the temperature at the junction of the bond wire and bond pad and directly affects the reliability of the device. The maximum recommended junction temperature for HiPerClockS devices is 125°C.

The equation for T_j is as follows: $T_j = \theta_{JA} * Pd_total + T_A$

T_j = Junction Temperature

θ_{JA} = Junction-to-Ambient Thermal Resistance

Pd_total = Total Device Power Dissipation (example calculation is in section 1 above)

T_A = Ambient Temperature

In order to calculate junction temperature, the appropriate junction-to-ambient thermal resistance θ_{JA} must be used. Assuming no air flow and a multi-layer board, the appropriate value is 70°C/W per Table 6 below.

Therefore, T_j for an ambient temperature of 70°C with all outputs switching is:

$$70^\circ\text{C} + 0.312\text{W} * 70^\circ\text{C}/\text{W} = 91.8^\circ\text{C}.$$

This is well below the limit of 125°C.

This calculation is only an example. T_j will obviously vary depending on the number of loaded outputs, supply voltage, air flow and the type of board (multi-layer).

Table 6. Thermal Resistance θ_{JA} for 24 Lead TSSOP, Forced Convection

| | θ_{JA} by Velocity | | |
|---|---------------------------|----------|--------|
| Meters per Second | 0 | 1 | 2.5 |
| Multi-Layer PCB, JEDEC Standard Test Boards | 70°C/W | 65.0°C/W | 62°C/W |

Reliability Information

Table 7. θ_{JA} vs. Air Flow Table for a 24 Lead TSSOP

| θ_{JA} by Velocity | | | |
|---|--------|----------|--------|
| Meters per Second | 0 | 1 | 2.5 |
| Multi-Layer PCB, JEDEC Standard Test Boards | 70°C/W | 65.0°C/W | 62°C/W |

Transistor Count

The transistor count for 85408 is: 1821

Pin compatible with SN65LVDS104

Package Outline and Package Dimensions

Package Outline - G Suffix for 24 Lead TSSOP

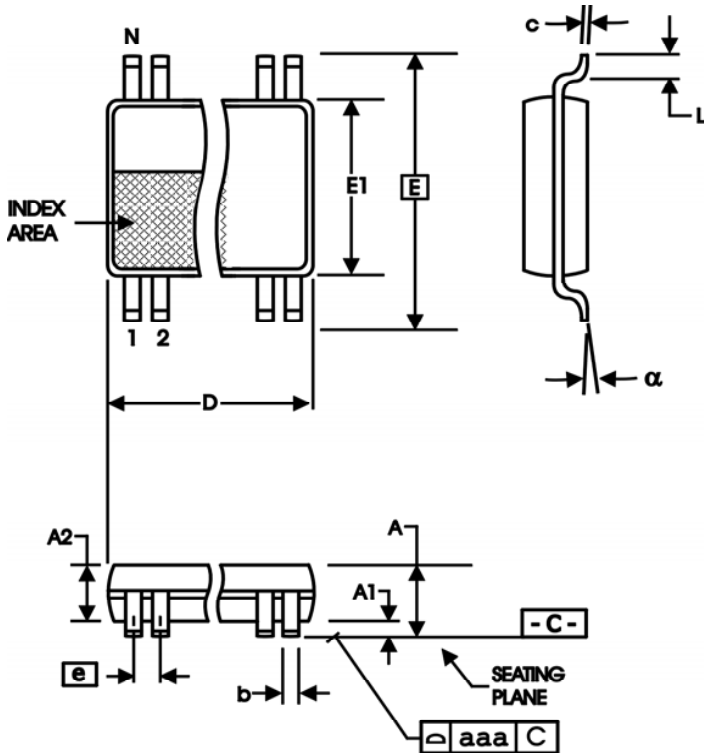

| All Dimensions in Millimeters | | |
|-------------------------------|------------|---------|
| Symbol | Minimum | Maximum |
| A2 | 0.80 | 1.05 |
| b | 0.19 | 0.30 |
| c | 0.09 | 0.20 |
| D | 7.70 | 7.90 |
| E | 6.40 Basic | |
| E1 | 4.30 | 4.50 |
| e | 0.65 Basic | |
| L | 0.45 | 0.75 |
| α | 0° | 8° |
| aaa | | 0.10 |

Reference Document: JEDEC Publication 95, MO-153

Table 8. Package Dimensions

| All Dimensions in Millimeters | | |
|-------------------------------|---------|---------|
| Symbol | Minimum | Maximum |
| N | 16 | |
| A | | 1.20 |
| A1 | 0.05 | 0.15 |

Ordering Information

Table 9. Ordering Information

| Part/Order Number | Marking | Package | Shipping Packaging | Temperature |
|-------------------|--------------|---------------------------|--------------------|-------------|
| 85408BGLF | ICS85408BGLF | "Lead-Free" 24 Lead TSSOP | Tube | 0°C to 70°C |
| 85408BGLFT | ICS85408BGLF | "Lead-Free" 24 Lead TSSOP | Tape & Reel | 0°C to 70°C |

NOTE: Parts that are ordered with an "LF" suffix to the part number are the Pb-Free configuration and are RoHS compliant.

Revision History Sheet

| Rev | Table | Page | Description of Change | Date |
|-----|----------|--------------|--|---------|
| A | T6 T8 | 9 11 | Reliability Table - revised air flow from Linear Feet per Minute to Meters per Second. Ordering Information Table - corrected typo in Part/Order Number from ICS8540BG to ICS85408BG. | 5/6/04 |
| A | | 1 | Pin Assignment - corrected package information from 300-MIL to 173-MIL. | 8/25/04 |
| A | T8 | 1 11 | Features Section - added <i>Lead-Free</i> bullet. Corrected Block Diagram. Ordering Information Table - added <i>Lead-Free</i> information. | 4/25/05 |
| A | T8 | 11 | Ordering Information Table - added <i>Lead-Free</i> part number. | 12/6/07 |
| B | T5 | 5 6 12 | AC Characteristics Table - added Additive Phase Jitter spec. Added Additive Phase Jitter Plot. Added <i>Power Considerations</i> section. Converted datasheet format. | 6/24/09 |
| C | T9 | 1 14 | Features section - removed leaded device references. Ordering information - removed leaded devices. PDN CQ-13-02 expired. Updated datasheet format. | 1/5/15 |

IMPORTANT NOTICE AND DISCLAIMER

RENESAS ELECTRONICS CORPORATION AND ITS SUBSIDIARIES (“RENESAS”) PROVIDES TECHNICAL SPECIFICATIONS AND RELIABILITY DATA (INCLUDING DATASHEETS), DESIGN RESOURCES (INCLUDING REFERENCE DESIGNS), APPLICATION OR OTHER DESIGN ADVICE, WEB TOOLS, SAFETY INFORMATION, AND OTHER RESOURCES “AS IS” AND WITH ALL FAULTS, AND DISCLAIMS ALL WARRANTIES, EXPRESS OR IMPLIED, INCLUDING, WITHOUT LIMITATION, ANY IMPLIED WARRANTIES OF MERCHANTABILITY, FITNESS FOR A PARTICULAR PURPOSE, OR NON-INFRINGEMENT OF THIRD-PARTY INTELLECTUAL PROPERTY RIGHTS.

These resources are intended for developers who are designing with Renesas products. You are solely responsible for (1) selecting the appropriate products for your application, (2) designing, validating, and testing your application, and (3) ensuring your application meets applicable standards, and any other safety, security, or other requirements. These resources are subject to change without notice. Renesas grants you permission to use these resources only to develop an application that uses Renesas products. Other reproduction or use of these resources is strictly prohibited. No license is granted to any other Renesas intellectual property or to any third-party intellectual property. Renesas disclaims responsibility for, and you will fully indemnify Renesas and its representatives against, any claims, damages, costs, losses, or liabilities arising from your use of these resources. Renesas' products are provided only subject to Renesas' Terms and Conditions of Sale or other applicable terms agreed to in writing. No use of any Renesas resources expands or otherwise alters any applicable warranties or warranty disclaimers for these products.

(Disclaimer Rev.1.01 Jan 2024)

Corporate Headquarters

TOYOSU FORESIA, 3-2-24 Toyosu,
Koto-ku, Tokyo 135-0061, Japan
www.renesas.com

Trademarks

Renesas and the Renesas logo are trademarks of Renesas Electronics Corporation. All trademarks and registered trademarks are the property of their respective owners.

Contact Information

For further information on a product, technology, the most up-to-date version of a document, or your nearest sales office, please visit www.renesas.com/contact-us/.