

GENERAL DESCRIPTION

The 87016 is a low skew, 1:16 LVCMOS/LVTTL Clock Generator. The device has 4 banks of 4 outputs and each bank can be independently selected for ± 1 or ± 2 frequency operation. Each bank also has its own power supply pins so that the banks can operate at the following different voltage levels: 3.3V, 2.5V, and 1.8V. The low impedance LVCMOS/LVTTL outputs are designed to drive 50Ω series or parallel terminated transmission lines.

The divide select inputs, DIV_SELA:DIV_SELD, control the output frequency of each bank. The output banks can be independently selected for ± 1 or ± 2 operation. The bank enable inputs, CLK_ENA:CLK_END, support enabling and disabling each bank of outputs individually. The CLK_ENA:CLK_END circuitry has a synchronizer to prevent runt pulses when enabling or disabling the clock outputs. The master reset input, nMR/OE, resets the $\pm 1/\pm 2$ flip flops and also controls the active and high impedance states of all outputs. This pin has an internal pull-up resistor and is normally used only for test purposes or in systems which use low power modes.

The 87016 is characterized to operate with the core at 3.3V and the banks at 3.3V, 2.5V, or 1.8V. Guaranteed bank, output, and part-to-part skew characteristics make the 87016 ideal for those clock applications demanding well-defined performance and repeatability.

FEATURES

- Sixteen LVCMOS/LVTTL outputs (4 banks of 4 outputs)
- Selectable differential CLK1, nCLK1 or LVCMOS clock input
- CLK1, nCLK1 pair can accept the following differential input levels: LVPECL, LVDS, LVHSTL, SSTL, HCSL
- CLK0 supports the following input types: LVCMOS, LVTTL
- Maximum output frequency: 250MHz
- Independent bank control for ± 1 or ± 2 operation
- Independent output bank voltage settings for 3.3V, 2.5V, or 1.8V operation
- Asynchronous clock enable/disable
- Output skew: 170ps (maximum)
- Bank skew: 30ps (maximum)
- Part-to-part skew: 750ps (maximum)
- 3.3V core, 3.3V, 2.5V, or 1.8V output operating supply
- 0°C to 85°C ambient operating temperature
- Available in lead-free RoHS compliant package

BLOCK DIAGRAM

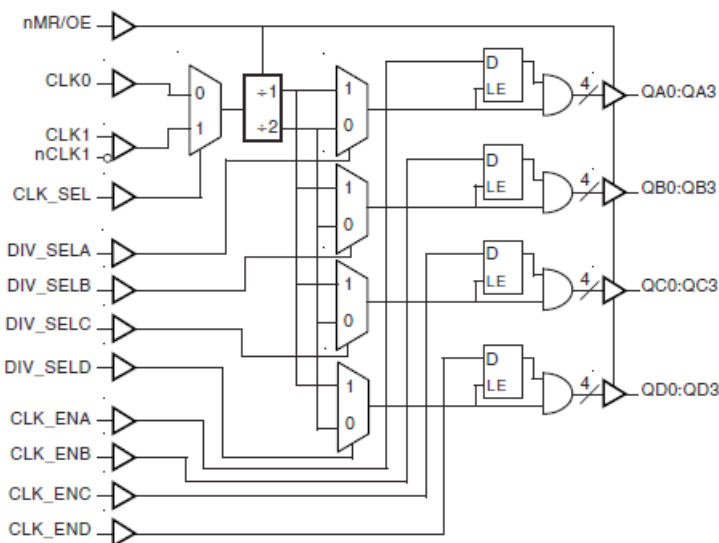

PIN ASSIGNMENT

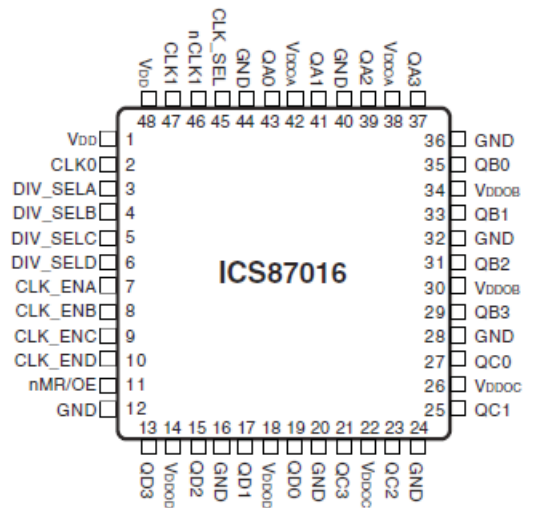

48-Pin LQFP

7mm x 7mm x 1.4mm body package
Y Package
Top View

TABLE 1. PIN DESCRIPTIONS

Number	Name	Type		Description
1, 48	V _{DD}	Power		Positive supply pins.
2	CLK0	Input	Pulldown	LVC MOS / LV TTL clock input.
3	DIV_SELA	Input	Pullup	Controls frequency division for Bank A outputs. LVC MOS / LV TTL interface levels.
4	DIV_SELB	Input	Pullup	Controls frequency division for Bank B outputs. LVC MOS / LV TTL interface levels.
5	DIV_SELC	Input	Pullup	Controls frequency division for Bank C outputs. LVC MOS / LV TTL interface levels.
6	DIV SELD	Input	Pullup	Controls frequency division for Bank D outputs. LVC MOS / LV TTL interface levels.
7	CLK_ENA	Input	Pullup	Output enable for Bank A outputs. Active HIGH. If pin is LOW, outputs drive low. LVC MOS / LV TTL interface levels.
8	CLK_ENB	Input	Pullup	Output enable for Bank B outputs. Active HIGH. If pin is LOW, outputs drive low. LVC MOS / LV TTL interface levels.
9	CLK_ENC	Input	Pullup	Output enable for Bank C outputs. Active HIGH. If pin is LOW, outputs drive low. LVC MOS / LV TTL interface levels.
10	CLK_END	Input	Pullup	Output enable for Bank D outputs. Active HIGH. If pin is LOW, outputs drive low. LVC MOS / LV TTL interface levels.
11	nMR/OE	Input	Pullup	Master reset. When LOW, resets the ÷1/÷2 flip flops and sets the outputs to high impedance. LVC MOS / LV TTL interface levels.
12, 16, 20, 24, 28, 32, 36, 40, 44	GND	Power		Power supply ground.
13, 15, 17, 19	QD3, QD2, QD1, QD0	Output		Bank D outputs. LVC MOS / LV TTL interface levels.
14, 18	V _{DDOD}	Power		Output Bank D power supply pins.
21, 23, 25, 27	QC3, QC2, QC1, QC0	Output		Bank C outputs. LVC MOS / LV TTL interface levels.
22, 26	V _{DDOC}	Power		Output Bank C power supply pins.
29, 31, 33, 35	QB3, QB2, QB1, QB0	Output		Bank B outputs. LVC MOS / LV TTL interface levels.
30, 34	V _{DDOB}	Power		Output Bank B power supply pins.
37, 39, 41, 43	QA3, QA2, QA1, QA0	Output		Bank A outputs. LVC MOS / LV TTL interface levels.
38, 42	V _{DDOA}	Power		Output Bank A power supply pins.
45	CLK_SEL	Input	Pulldown	Clock select input. When HIGH, selects CLK1, nCLK1 inputs. When LOW, selects CLK0 input. LVC MOS / LV TTL interface levels.
46	nCLK1	Input	Pullup	Inverting differential clock input.
47	CLK1	Input	Pulldown	Non-inverting differential clock input.

NOTE: *Pullup* and *Pulldown* refer to internal input resistors. See Table 2, Pin Characteristics, for typical values.

TABLE 2. PIN CHARACTERISTICS

Symbol	Parameter	Test Conditions	Minimum	Typical	Maximum	Units
C_{IN}	Input Capacitance			4		pF
R_{PULLUP}	Input Pullup Resistor			51		k Ω
C_{PD}	Power Dissipation Capacitance (per output); NOTE 1	$V_{DD}, V_{DDOx} = 3.465V$			18	pF
		$V_{DD} = 3.465, V_{DDOx} = 2.625V$			20	pF
		$V_{DD} = 3.465, V_{DDOx} = 1.89V$			30	pF
R_{OUT}	Output Impedance			7		Ω

NOTE 1: V_{DDOx} denotes $V_{DDOAx}, V_{DDOBx}, V_{DDOCx}$, and V_{DDODx} .

TABLE 3. FUNCTION TABLE

Inputs			Outputs	
nMR/OE	CLK_ENx	DIV_SELx	Bank X	Qx Frequency
0	X	X	Hi Z	N/A
1	1	0	Active	fIN/2
1	1	1	Active	fIN
1	0	X	Low	N/A

ABSOLUTE MAXIMUM RATINGS

Supply Voltage, V_{DD}	4.6V
Inputs, V_I	-0.5V to $V_{DD} + 0.5V$
Outputs, V_O	-0.5V to $V_{DDOx} + 0.5V$
Package Thermal Impedance, θ_{JA}	47.9°C/W (0 lfm)
Storage Temperature, T_{STG}	-65°C to 150°C

NOTE: Stresses beyond those listed under Absolute Maximum Ratings may cause permanent damage to the device. These ratings are stress specifications only. Functional operation of product at these conditions or any conditions beyond those listed in the *DC Characteristics* or *AC Characteristics* is not implied. Exposure to absolute maximum rating conditions for extended periods may affect product reliability.

TABLE 4A. POWER SUPPLY DC CHARACTERISTICS, $V_{DD} = 3.3V \pm 5\%$, $T_A = 0^\circ C$ TO $85^\circ C$

Symbol	Parameter	Test Conditions	Minimum	Typical	Maximum	Units
V_{DD}	Positive Supply Voltage		3.135	3.3	3.465	V
V_{DDOx}	Output Supply Voltage; NOTE 1		3.135	3.3	3.465	V
			2.375	2.5	2.625	V
			1.71	1.8	1.89	V
I_{DD}	Power Supply Current			100	mA	
I_{DDOx}	Output Supply Current; NOTE 2			15	mA	

NOTE 1: V_{DDOx} denotes V_{DDOxA} , V_{DDOxB} , V_{DDOC} , and V_{DDOD} . NOTE 2: I_{DDOx} denotes I_{DDOxA} , I_{DDOxB} , I_{DDOC} , and I_{DDOD} .

TABLE 4B. LVCMOS/LVTTL DC CHARACTERISTICS, $V_{DD} = 3.3V \pm 5\%$, $T_A = 0^\circ C$ TO $85^\circ C$

Symbol	Parameter	Test Conditions	Minimum	Typical	Maximum	Units
V_{IH}	Input High Voltage	DIV_SELA:DIV_SELD, CLK_ENA:CLK_END, nMR/OE, CLK_SEL	2		V + 0.3	V
		CLK0	2		V + 0.3	V
V_{IL}	Input Low Voltage	DIV_SELA:DIV_SELD, CLK_ENA:CLK_END, nMR/OE, CLK_SEL	-0.3		0.8	V
		CLK0	-0.3		1.3	V
I_{IH}	Input High Current	CLK_ENA:CLK_END, DIV_SELA:DIV_SELD, nMR/OE	V = V = 3.465V		5	μA
		CLK0, CLK_SEL	V = V = 3.465V		150	μA
I_{IL}	Input Low Current	CLK_ENA:CLK_END, DIV_SELA:DIV_SELD, nMR/OE	V = 3.465V, V = 0V		-150	μA
		CLK0, CLK_SEL	V = 3.465V, V = 0V		-5	μA
V_{OH}	Output High Voltage; NOTE 1	V = 3.3V \pm 5%; NOTE 2	2.6			V
		V = 2.5V \pm 5%; NOTE 2	1.8			V
		V = 1.8V \pm 5%; NOTE 2 I = -2mA	$V_{DDOx} - 0.45$			V
V_{OL}	Output Low Voltage; NOTE 1	V = 3.3V \pm 5%; NOTE 2			0.5	V
		V = 2.5V \pm 5%; NOTE 2			0.5	V
		V = 1.8V \pm 5%; NOTE 2 I = 2mA			0.45	V
I_{OZL}	Output Tristate Current Low		-5			μA
I_{OZH}	Output Tristate Current High			5		μA

NOTE 1: Outputs terminated with 50W to $V_{DDOx}/2$. See Parameter Measurement Information, Output Load Test Circuit.

NOTE 2: V_{DDOx} denotes V_{DDOxA} , V_{DDOxB} , V_{DDOC} and V_{DDOD} .

TABLE 4C. DIFFERENTIAL DC CHARACTERISTICS, $V_{DD} = 3.3V \pm 5\%$, $T_A = 0^\circ C$ TO $85^\circ C$

Symbol	Parameter	Test Conditions	Minimum	Typical	Maximum	Units
I_{IH}	Input High Current	nCLK1	$V_{IN} = V_{DD} = 3.465V$		5	μA
		CLK1	$V_{IN} = V_{DD} = 3.465V$		150	μA
I_{IL}	Input Low Current	nCLK1	$V_{IN} = 0V, V_{DD} = 3.465V$	-150		μA
		CLK1	$V_{IN} = 0V, V_{DD} = 3.465V$	-5		μA
V_{PP}	Peak-to-Peak Input Voltage		0.15		1.3	V
V_{CMR}	Common Mode Input Voltage; NOTE 1, 2		GND + 0.5		$V_{DD} - 0.85$	V

NOTE 1: For single ended applications, the maximum input voltage for CLK1, nCLK1 is $V_{DD} + 0.3V$.

NOTE 2: Common mode voltage is defined as V_{IH} .

TABLE 5A. AC CHARACTERISTICS, $V_{DD} = V_{DDOX} = 3.3V \pm 5\%$, $T_A = 0^\circ C$ TO $85^\circ C$

Symbol	Parameter	Test Conditions	Minimum	Typical	Maximum	Units
f_{MAX}	Output Frequency				250	MHz
t_{pLH}	Propagation Delay, Low to High	CLK0; NOTE 1A	2.8	3.2	3.7	ns
		CLK1, nCLK1; NOTE 1B	2.9	3.4	3.9	ns
$tsk(b)$	Bank Skew; NOTE 2, 7	Measured on the Rising Edge			30	ps
$tsk(o)$	Output Skew; NOTE 3, 7	Measured on the Rising Edge			150	ps
$tsk(pp)$	Part-to-Part Skew; NOTE 5, 7				750	ps
t_R / t_F	Output Rise/Fall Time; NOTE 6	20% to 80%	200		700	ps
odc	Output Duty Cycle	$f < 175MHz$	45		55	%
		$f \geq 175MHz$	40		60	%
t_{EN}	Output Enable Time; NOTE 6				10	ns
t_{DIS}	Output Disable Time; NOTE 6				10	ns

All parameters measured at 250MHz unless noted otherwise.

NOTE 1A: Measured from the $V_{DD}/2$ of the input to $V_{DDOX}/2$ of the output.

NOTE 1B: Measured from the differential input crossing point to $V_{DDOX}/2$ of the output.

NOTE 2: Defined as skew within a bank with equal load conditions.

NOTE 3: Defined as skew between outputs at the same supply voltage and with equal load conditions.

Measured at $V_{DDOX}/2$.

NOTE 4: Defined as skew across banks of outputs switching in the same direction operating at different frequencies with the same supply voltages and equal load conditions. Measured at $V_{DDOX}/2$.

NOTE 5: Defined as skew between outputs on different devices operating at the same supply voltages and with equal load conditions. Using the same type of input on each device, the output is measured at $V_{DDOX}/2$.

NOTE 6: These parameters are guaranteed by characterization. Not tested in production.

NOTE 7: This parameter is defined in accordance with JEDEC Standard 65.

TABLE 5B. AC CHARACTERISTICS, $V_{DD} = 3.3V \pm 5\%$, $V_{DDOX} = 2.5V \pm 5\%$, $T_A = 0^\circ C$ TO $85^\circ C$

Symbol	Parameter	Test Conditions	Minimum	Typical	Maximum	Units
f_{MAX}	Output Frequency				250	MHz
t_{pLH}	Propagation Delay, Low to High	CLK0; NOTE 1A	2.9	3.3	3.8	ns
		CLK1, nCLK1; NOTE 1B	3	3.5	4	ns
$t_{sk(b)}$	Bank Skew; NOTE 2, 7	Measured on the Rising Edge			30	ps
$t_{sk(o)}$	Output Skew; NOTE 3, 7	Measured on the Rising Edge			160	ps
$t_{sk(pp)}$	Part-to-Part Skew; NOTE 5, 7				750	ps
t_R / t_F	Output Rise/Fall Time; NOTE 6	20% to 80%	200		700	ps
odc	Output Duty Cycle	$f < 175MHz$	45		55	%
		$f \geq 175MHz$	40		60	%
t_{EN}	Output Enable Time; NOTE 6				10	ns
t_{DIS}	Output Disable Time; NOTE 6				10	ns

All parameters measured at 250MHz unless noted otherwise.

NOTE 1A: Measured from the $V_{DD}/2$ of the input to $V_{DDOX}/2$ of the output.

NOTE 1B: Measured from the differential input crossing point to $V_{DDOX}/2$ of the output.

NOTE 2: Defined as skew within a bank with equal load conditions.

NOTE 3: Defined as skew between outputs at the same supply voltage and with equal load conditions.

Measured at $V_{DDOX}/2$.

NOTE 4: Defined as skew across banks of outputs switching in the same direction operating at different frequencies with the same supply voltages and equal load conditions. Measured at $V_{DDOX}/2$.

NOTE 5: Defined as skew between outputs on different devices operating at the same supply voltages and with equal load conditions. Using the same type of input on each device, the output is measured at $V_{DDOX}/2$.

NOTE 6: These parameters are guaranteed by characterization. Not tested in production.

NOTE 7: This parameter is defined in accordance with JEDEC Standard 65.

TABLE 5C. AC CHARACTERISTICS, $V_{DD} = 3.3V \pm 5\%$, $V_{DDOX} = 1.8V \pm 5\%$, $T_A = 0^\circ C$ TO $85^\circ C$

Symbol	Parameter	Test Conditions	Minimum	Typical	Maximum	Units
f_{MAX}	Output Frequency				250	MHz
t_{pLH}	Propagation Delay, Low to High	CLK0; NOTE 1A	3.1	3.8	4.5	ns
		CLK1, nCLK1; NOTE 1B	3.1	3.8	4.5	ns
$t_{sk(b)}$	Bank Skew; NOTE 2, 7	Measured on the Rising Edge			30	ps
$t_{sk(o)}$	Output Skew; NOTE 3, 7	Measured on the Rising Edge			170	ps
$t_{sk(pp)}$	Part-to-Part Skew; NOTE 5, 7				750	ps
t_R / t_F	Output Rise/Fall Time; NOTE 6	20% to 80%	200		700	ps
odc	Output Duty Cycle	$f < 175MHz$	45		55	%
		$f \geq 175MHz$	40		60	%
t_{EN}	Output Enable Time; NOTE 6				10	ns
t_{DIS}	Output Disable Time; NOTE 6				10	ns

All parameters measured at 250MHz unless noted otherwise.

NOTE 1A: Measured from the $V_{DD}/2$ of the input to $V_{DDOX}/2$ of the output.

NOTE 1B: Measured from the differential input crossing point to $V_{DDOX}/2$ of the output.

NOTE 2: Defined as skew within a bank with equal load conditions.

NOTE 3: Defined as skew between outputs at the same supply voltage and with equal load conditions.

Measured at $V_{DDOX}/2$.

NOTE 4: Defined as skew across banks of outputs switching in the same direction operating at different frequencies with the same supply voltages and equal load conditions. Measured at $V_{DDOX}/2$.

NOTE 5: Defined as skew between outputs on different devices operating at the same supply voltages and with equal load conditions. Using the same type of input on each device, the output is measured at $V_{DDOX}/2$.

NOTE 6: These parameters are guaranteed by characterization. Not tested in production.

NOTE 7: This parameter is defined in accordance with JEDEC Standard 65.

PARAMETER MEASUREMENT INFORMATION

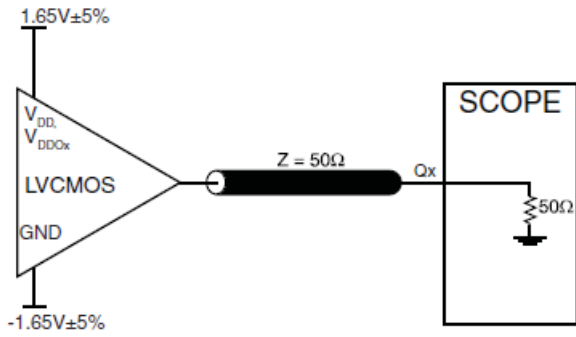

3.3V OUTPUT LOAD AC TEST CIRCUIT

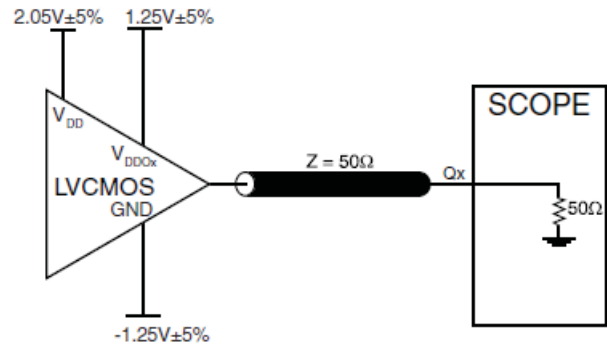

3.3V/2.5V OUTPUT LOAD AC TEST CIRCUIT

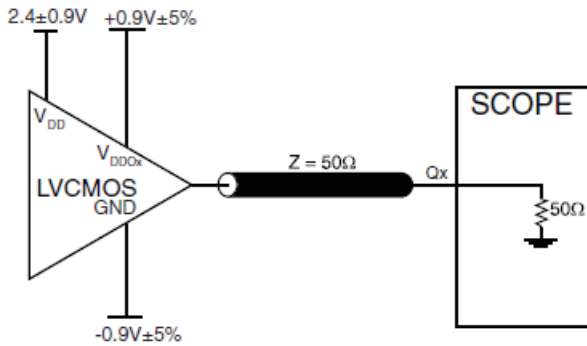

3.3V/1.8V OUTPUT LOAD AC TEST CIRCUIT

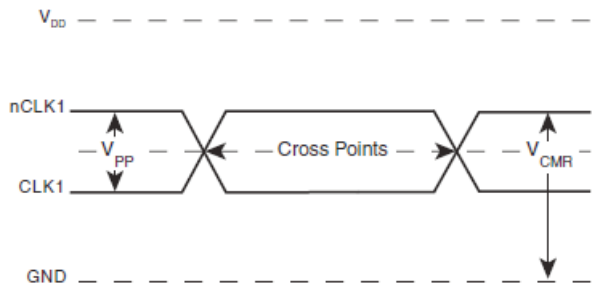

DIFFERENTIAL INPUT LEVEL

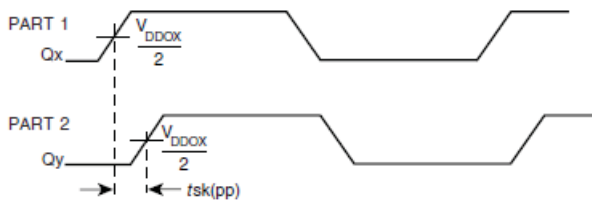

PART-TO-PART SKEW

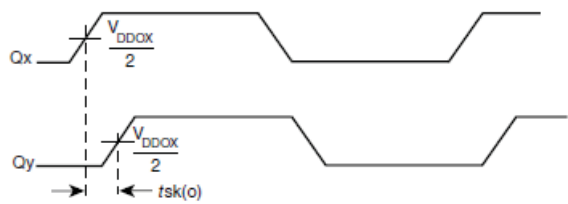

OUTPUT SKEW

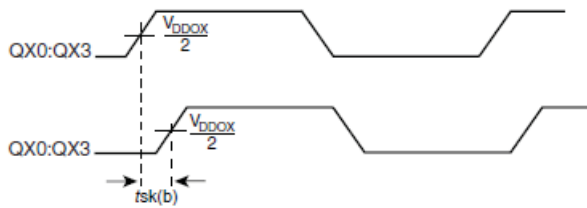

BANK SKEW (where X denotes outputs in the same bank)

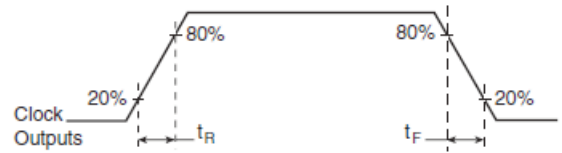

OUTPUT RISE/FALL TIME

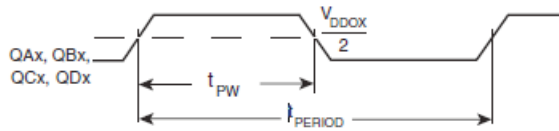

$$odc = \frac{t_{PW}}{t_{PERIOD}} \times 100\%$$

OUTPUT DUTY CYCLE/PULSE WIDTH/PERIOD

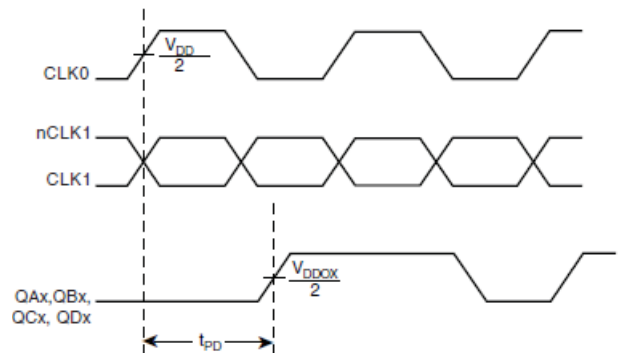

PROPAGATION DELAY

APPLICATION INFORMATION

WIRING THE DIFFERENTIAL INPUT TO ACCEPT SINGLE ENDED LEVELS

Figure 1 shows how the differential input can be wired to accept single ended levels. The reference voltage $V_{REF} = V_{DD}/2$ is generated by the bias resistors R1, R2 and C1. This bias circuit should be located as close as possible to the input pin. The ratio

of R1 and R2 might need to be adjusted to position the V_{REF} in the center of the input voltage swing. For example, if the input clock swing is only 2.5V and $V_{DD} = 3.3V$, V_{REF} should be 1.25V and $R2/R1 = 0.609$.

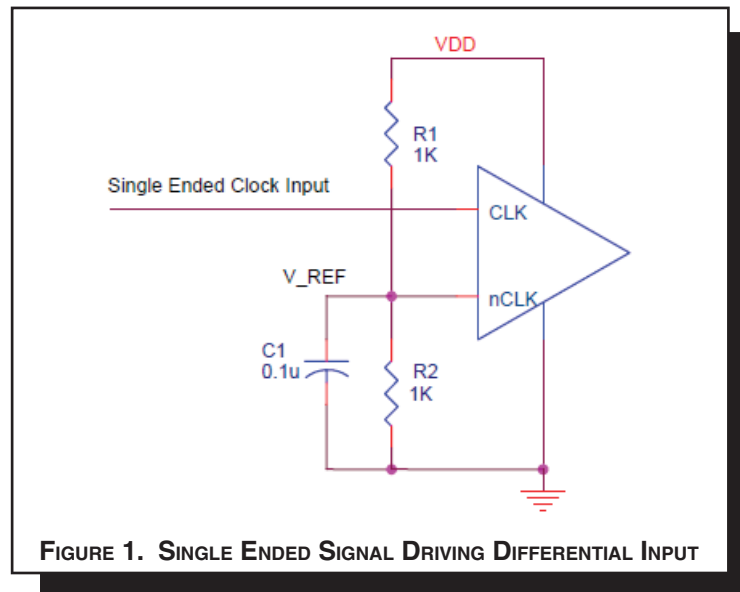

FIGURE 1. SINGLE ENDED SIGNAL DRIVING DIFFERENTIAL INPUT

RECOMMENDATIONS FOR UNUSED INPUT AND OUTPUT PINS

INPUTS:

CLK INPUT:

For applications not requiring the use of a clock input, it can be left floating. Though not required, but for additional protection, a 1kΩ resistor can be tied from the CLK input to ground.

CLK/nCLK INPUT:

For applications not requiring the use of the differential input, both CLK and nCLK can be left floating. Though not required, but for additional protection, a 1kΩ resistor can be tied from CLK to ground.

LVC MOS CONTROL PINS:

All control pins have internal pull-ups or pull-downs; additional resistance is not required but can be added for additional protection. A 1kΩ resistor can be used.

OUTPUTS:

LVC MOS OUTPUT:

All unused LVC MOS output can be left floating. We recommend that there is no trace attached.

DIFFERENTIAL CLOCK INPUT INTERFACE

The CLK/nCLK accepts LVDS, LVPECL, LVHSTL, SSTL, HCSSL and other differential signals. Both V_{SWING} and V_{OH} must meet the V_{PP} and V_{CMR} input requirements. Figures 4A to 4E show interface examples for the CLK/nCLK input driven by the most common driver types. The input interfaces suggested here are examples only. Please consult with the vendor of the driver

component to confirm the driver termination requirements. For example in *Figure 2A*, the input termination applies for LVHSTL drivers. If you are using an LVHSTL driver from another vendor, use their termination recommendation.

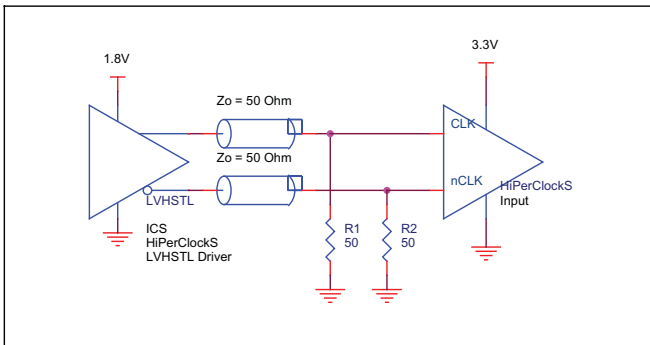

FIGURE 2A. CLK/nCLK INPUT DRIVEN BY LVHSTL DRIVER

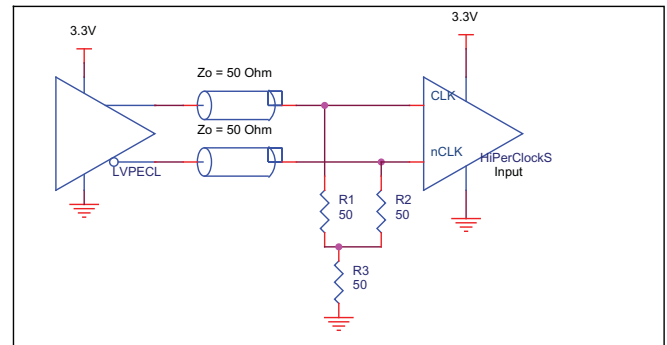

FIGURE 2B. CLK/nCLK INPUT DRIVEN BY 3.3V LVPECL DRIVER

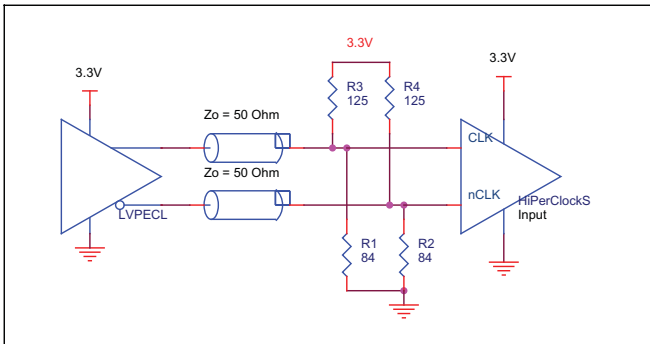

FIGURE 2C. CLK/nCLK INPUT DRIVEN BY 3.3V LVPECL DRIVER

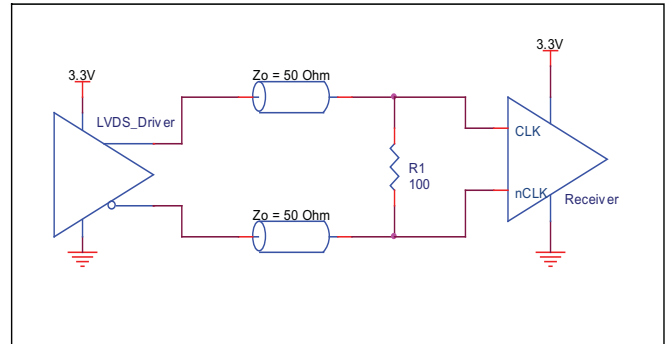

FIGURE 2D. CLK/nCLK INPUT DRIVEN BY 3.3V LVDS DRIVER

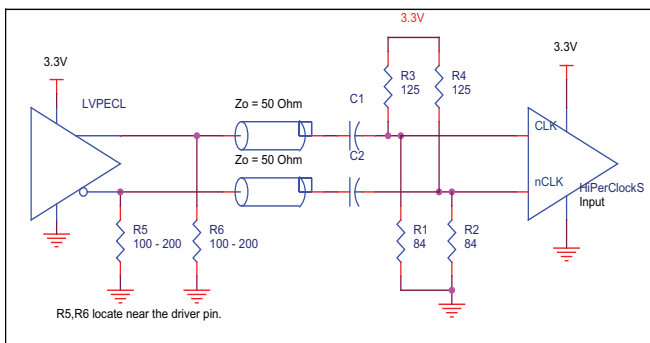

FIGURE 2E. CLK/nCLK INPUT DRIVEN BY 3.3V LVPECL DRIVER WITH AC COUPLE

SCHEMATIC EXAMPLE

Figure 3 shows an application schematic example of the 87016. This schematic provides examples of input and output handling. The differential CLK1/nCLK1 input can accept various types of differential signal. This example shows the 87016 input driven by a 3.3V LVPECL driver. Additional examples for the input driven by other types of drivers are shown in the application section of this data sheet. The single ended input CLK0 is driven by a 7Ω

LVMCOS driver through series termination. The 87016 outputs are LVMCOS drivers. Series termination is shown in this schematic. Additional LVMCOS termination approaches are shown in the LVMCOS Termination Application Note.

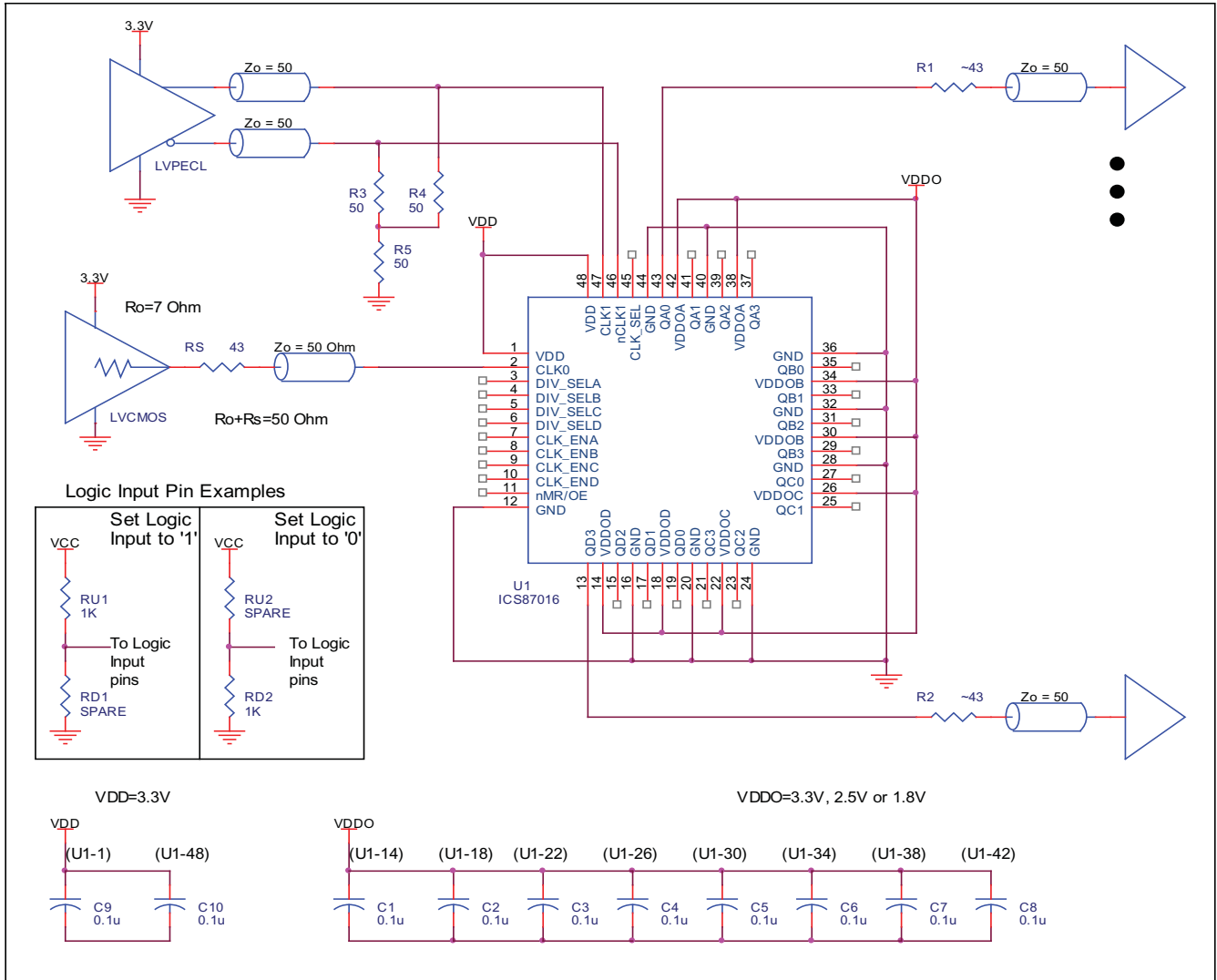

FIGURE 3. APPLICATION SCHEMATIC EXAMPLE

RELIABILITY INFORMATION

TABLE 6. θ_{JA} VS. AIR FLOW TABLE FOR 48 LEAD LQFP

θ_{JA} by Velocity (Linear Feet per Minute)			
	0	200	500
Single-Layer PCB, JEDEC Standard Test Boards	67.8°C/W	55.9°C/W	50.1°C/W
Multi-Layer PCB, JEDEC Standard Test Boards	47.9°C/W	42.1°C/W	39.4°C/W

NOTE: Most modern PCB designs use multi-layered boards. The data in the second row pertains to most designs.

TRANSISTOR COUNT

The transistor count for 87016 is: 2034

Package Outline Drawings

The package outline drawings are appended at the end of this document and are accessible from the link below. The package information is the most current data available.

www.idt.com/us/en/document/cpt/prprg-package-outline-70-x-70-x-14-mm-tqfp-10010-form

TABLE 8. ORDERING INFORMATION

Part/Order Number	Marking	Package	Shipping Packaging	Temperature
87016AYLF	ICS87016AYLF	48 Lead "Lead-Free" LQFP	tray	0°C to 85°C
87016AYLFT	ICS87016AYLF	48 Lead "Lead-Free" LQFP	tape & reel, pin 1 orientation: EIA-481-C	0°C to 85°C
87016AYLF/W	ICS87016AYLF	48 Lead "Lead-Free" LQFP	tape & reel, pin 1 orientation EIA-481-D	0°C to 85°C

NOTE: Parts that are ordered with an "LF" suffix to the part number are the Pb-Free configuration and are RoHS compliant.

TABLE 9. PIN 1 ORIENTATION IN TAPE AND REEL PACKAGING

Part Number Suffix	Pin 1 Orientation	Illustration
8	Quadrant 1 (EIA-481-C)	
W	Quadrant 2 (EIA-481-D)	

REVISION HISTORY SHEET

Rev	Table	Page	Description of Change	Date
A	T5A, T5B, T5C	6, 7, 8	AC Characteristics Table - corrected the first line in the Notes section, from "All parameters measured at 150MHz..." to 250MHz.	7/31/02
A			Revised part description title from "Differential-to-LVCMOS Clock Generator" to "LVCMOS Clock Generator".	8/9/02
A	T5A & T5B	6 & 7 12	AC Characteristics Table - switched prop delay values for CLK0 and CLK1, nCLK1. Added Differential Clock Input Interface section. Updated format.	5/05/03
A		1	Modified Block Diagram, corrected latch block.	6/4/03
A		12	Added Schematic Example	12/10/04
A		1 10	Features Section - added Lead-Free bullet. Application Section - added <i>Recommendations for Unused Input and Output Pins</i> .	2/28/06
	T8	15	Ordering Information Table - add Lead-Free part number, marking and note.	
A	T8	15 17	Updated datasheet's header/footer with IDT from ICS. Removed ICS prefix from Part/Order Number column. Added Contact Page.	7/29/10
B	T4B	4	LVCMOS DC Characteristics Table - corrected typo for 1.8V V_{OH} min. spec from $V_{DD} - 0.45$ to $V_{DD0x} - 0.45$.	4/4/13
C		1	Updated datasheet format.	1/12/15
	T8	15	Features section - removed reference to leaded device. Ordering Information - removed leaded devices - PDN CQ-13-02.	
C	T9	15	Added Pin 1 Orientation in Tape and Reel Packaging Table.	6/26/15
			Updated Package Outline Drawings section; added link.	01/21/20

IMPORTANT NOTICE AND DISCLAIMER

RENESAS ELECTRONICS CORPORATION AND ITS SUBSIDIARIES (“RENESAS”) PROVIDES TECHNICAL SPECIFICATIONS AND RELIABILITY DATA (INCLUDING DATASHEETS), DESIGN RESOURCES (INCLUDING REFERENCE DESIGNS), APPLICATION OR OTHER DESIGN ADVICE, WEB TOOLS, SAFETY INFORMATION, AND OTHER RESOURCES “AS IS” AND WITH ALL FAULTS, AND DISCLAIMS ALL WARRANTIES, EXPRESS OR IMPLIED, INCLUDING, WITHOUT LIMITATION, ANY IMPLIED WARRANTIES OF MERCHANTABILITY, FITNESS FOR A PARTICULAR PURPOSE, OR NON-INFRINGEMENT OF THIRD-PARTY INTELLECTUAL PROPERTY RIGHTS.

These resources are intended for developers who are designing with Renesas products. You are solely responsible for (1) selecting the appropriate products for your application, (2) designing, validating, and testing your application, and (3) ensuring your application meets applicable standards, and any other safety, security, or other requirements. These resources are subject to change without notice. Renesas grants you permission to use these resources only to develop an application that uses Renesas products. Other reproduction or use of these resources is strictly prohibited. No license is granted to any other Renesas intellectual property or to any third-party intellectual property. Renesas disclaims responsibility for, and you will fully indemnify Renesas and its representatives against, any claims, damages, costs, losses, or liabilities arising from your use of these resources. Renesas' products are provided only subject to Renesas' Terms and Conditions of Sale or other applicable terms agreed to in writing. No use of any Renesas resources expands or otherwise alters any applicable warranties or warranty disclaimers for these products.

(Disclaimer Rev.1.01)

Corporate Headquarters

TOYOSU FORESIA, 3-2-24 Toyosu,
Koto-ku, Tokyo 135-0061, Japan
www.renesas.com

Trademarks

Renesas and the Renesas logo are trademarks of Renesas Electronics Corporation. All trademarks and registered trademarks are the property of their respective owners.

Contact Information

For further information on a product, technology, the most up-to-date version of a document, or your nearest sales office, please visit www.renesas.com/contact-us/.