

Description

The IDT8L3010I is a low skew, 1-to-10 LVCMOS / LVTTTL Fanout Buffer. The low impedance LVCMOS/LVTTTL outputs are designed to drive 50Ω series or parallel terminated transmission lines.

The IDT8L3010I is characterized at full 3.3V and 2.5V, mixed 3.3V/2.5V, 3.3V/1.8V, 3.3V/1.5V, 2.5V/1.8V and 2.5V/1.5V output operating supply modes. The input clock is selected from two differential clock inputs or a crystal input. The differential input can be wired to accept a single-ended input. The internal oscillator circuit is automatically disabled if the crystal input is not selected.

Features

- Ten LVCMOS / LVTTTL outputs up to 200MHz
- Differential input pair can accept the following differential input levels: LVPECL, LVDS, HCSL
- Crystal Oscillator Interface
- Crystal input frequency range: 10MHz to 40MHz
- Output skew: 50ps (maximum) @ 3.3V/3.3V
- Additive RMS phase jitter: 0.24ps (typical) @ 3.3V/3.3V
- Synchronous output enable to avoid clock glitch
- Power supply modes:
Core / Output
3.3V / 3.3V
2.5V / 2.5V
3.3V / 2.5V
3.3V / 1.8V
3.3V / 1.5V
2.5V / 1.8V
2.5V / 1.5V
- 5V input tolerance
- -40°C to 85°C ambient operating temperature
- Available in lead-free (RoHS 6) package

Block Diagram

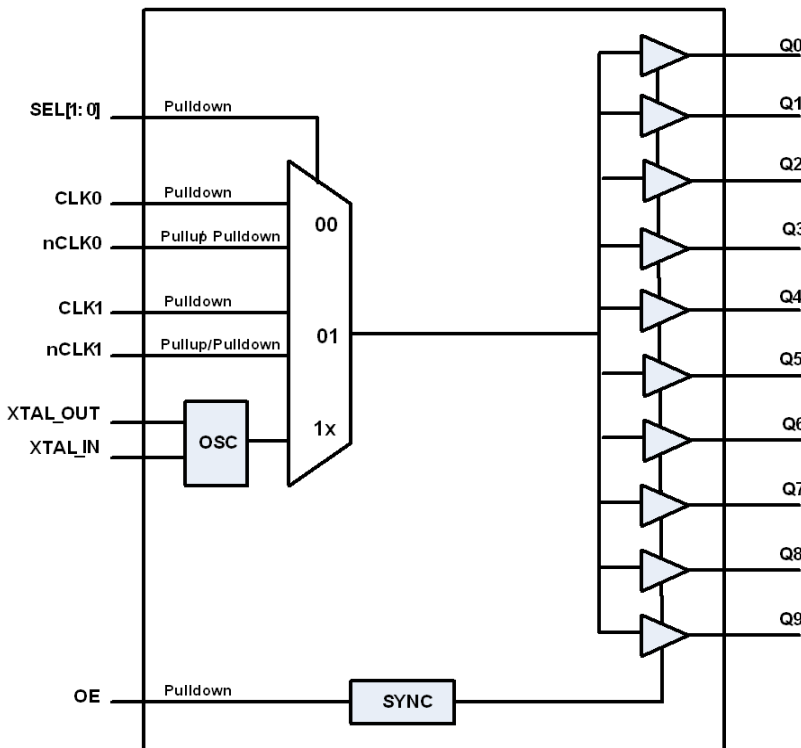

Pin Assignment

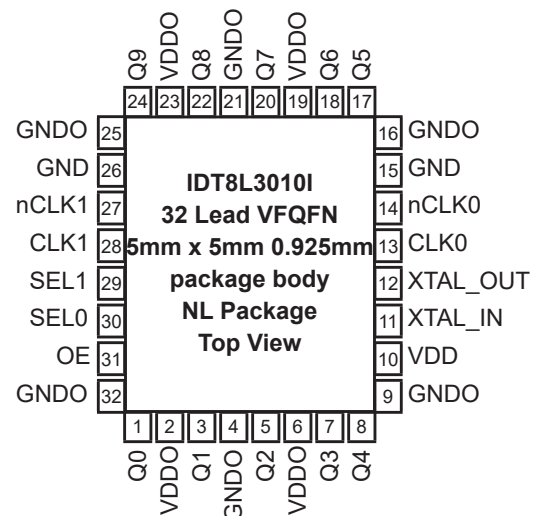

Table 1. Pin Descriptions

Number	Name	Type		Description
1, 3, 5, 7, 8, 17, 18, 20, 22, 24	Q0, Q1, Q2, Q3, Q4 Q5, Q6, Q7, Q8, Q9	Output		Single-ended clock outputs. LVCMOS/LVTTL interface levels.
2, 6, 19, 23	V _{DDO}	Power		Output supply pins.
4, 9, 16, 21, 25, 32	GNDO	Power		Power supply output ground.
15, 26	GND	Power		Power supply core ground.
10	V _{DD}	Power		Power supply pin.
11, 12	XTAL_IN, XTAL_OUT	Input		Crystal oscillator interface. XTAL_IN is the input, XTAL_OUT is the output.
13	CLK0	Input	Pulldown	Non-inverting differential clock.
14	nCLK0	Input	Pullup/ Pulldown	Inverting differential clock. Internal resistor bias to V _{DD} /2.
27	nCLK1	Input	Pullup/ Pulldown	Inverting differential clock. Internal resistor bias to V _{DD} /2.
28	CLK1	Input	Pulldown	Non-inverting differential clock.
29, 30	SEL1, SEL0	Input	Pulldown	Input clock selection. LVCMOS/LVTTL interface levels. See Table 3A.
31	OE	Input	Pulldown	Output enable. LVCMOS/LVTTL interface levels. See Table 3B.

NOTE: Pullup and Pulldown refer to internal input resistors. See Table 2, *Pin Characteristics*, for typical values.

Table 2. Pin Characteristics

Symbol	Parameter	Test Conditions	Minimum	Typical	Maximum	Units
C _{IN}	Input Capacitance			4		pF
R _{PULLDOWN}	Input Pulldown Resistor			51		kΩ
R _{PULLUP}	Input Pullup Resistor			51		kΩ
C _{PD}	Power Dissipation Capacitance (per output)	V _{DDO} = 3.465V		13		pF
		V _{DDO} = 2.625V		12		pF
		V _{DDO} = 2V		10		pF
		V _{DDO} = 1.65V		9		pF
R _{OUT}	Output Impedance	V _{DDO} = 3.3V ± 5%		14		Ω
		V _{DDO} = 2.5V ± 5%		17		Ω
		V _{DDO} = 1.8V ± 0.2V		30		Ω
		V _{DDO} = 1.5V ± 0.15V		55		Ω

Function Tables

Table 3A. SELx Function Table

Control Input	Selected Input Clock
SEL[1:0]	
00 (default)	CLK0, nCLK0
01	CLK1, nCLK1
11 or 10	XTAL

Table 3B. OE Function Table

Control Input	Function
OE	Q[0:9]
0 (default)	High-Impedance
1	Enabled

Table 3C. Input/Output Operation Table

Input State			Output State
OE	SEL[1:0]	CLK[0:1], nCLK[0:1]	Q[0:9]
0	X	Do Not Care	High-Impedance
1	10 or 11	Do Not Care	Active
1	00	CLK0=nCLK0 =Open	LOW
		CLK0=nCLK0 =Ground	LOW
		CLK0 = HIGH, nCLK0 = LOW	HIGH
		CLK0 = LOW, nCLK0 = HIGH	LOW
1	01	CLK1=nCLK1 =Open	LOW
		CLK1=nCLK1 =Ground	LOW
		CLK1 = HIGH, nCLK1 = LOW	HIGH
		CLK1 = LOW, nCLK1 = HIGH	LOW

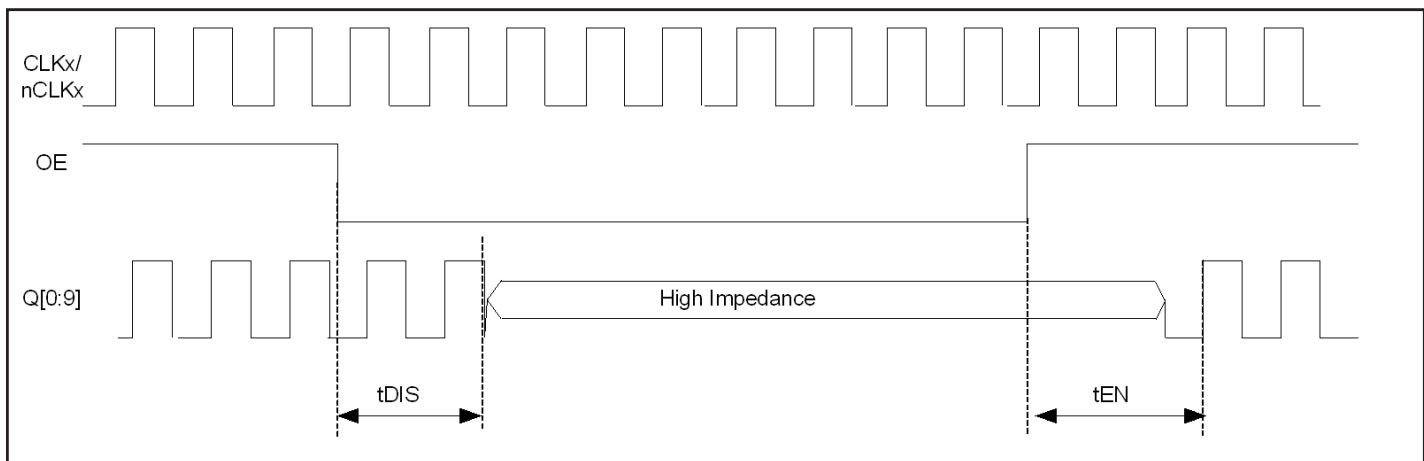

Figure 1. OE Timing Diagram

NOTE: The outputs will enable or disable following 2 to 3 clock cycles after the transition on the OE input.

Absolute Maximum Ratings

Exposure to absolute maximum rating conditions for extended periods may affect product reliability. Stresses beyond those listed under *Absolute Maximum Ratings* may cause permanent damage to the device. These ratings are stress specifications only. Functional operation of product at these conditions or any conditions beyond those listed in the *DC Characteristics* or *AC Characteristics* is not implied.

Item	Rating
Supply Voltage, V_{DD}	3.63V
Inputs, V_I CLK _X , nCLK _X , XTAL_IN Other Inputs	0V to 5V 0V to 2V -0.5V to $V_{DD} + 0.5V$
Outputs, V_O	-0.5V to $V_{DDO} + 0.5V$
Package Thermal Impedance, θ_{JA}	33.1°C/W (0 mps)
Maximum Junction Temperature, $T_{J,MAX}$	150°C
Storage Temperature, T_{STG}	-65°C to 150°C

Recommended Operating Conditions

Symbol	Parameter	Minimum	Typical	Maximum	Units
T_A	Ambient air temperature	-40		85	°C
T_J	Junction temperature			125	°C

NOTE 1: It is the user's responsibility to ensure that device junction temperature remains below the maximum allowed.

NOTE 2: All conditions in the table must be met to guarantee device functionality.

NOTE 3: The device is verified to the maximum operating junction temperature through simulation.

DC Electrical Characteristics

Table 4A. Power Supply DC Characteristics, $V_{DD} = 3.3V \pm 5\%$, $V_{DDO} = 3.3V \pm 5\%$ or $2.5V \pm 5\%$ or $1.8V \pm 0.2V$ or $1.5V \pm 0.15V$, $T_A = -40^\circ\text{C}$ to 85°C

Symbol	Parameter	Test Conditions	Minimum	Typical	Maximum	Units
V_{DD}	Power Supply Voltage		3.135	3.3	3.465	V
V_{DDO}	Output Supply Voltage		3.135	3.3	3.465	V
			2.375	2.5	2.625	V
			1.6	1.8	2	V
			1.35	1.5	1.65	V
I_{DD}	Power Supply Current	OE = 0			38	mA
I_{DDO}	Output Supply Current	OE = 1, $V_{DDO} = 3.3V \pm 5\%$, Outputs Unloaded			5	mA
		OE = 1, $V_{DDO} = 2.5V \pm 5\%$, Outputs Unloaded			5	mA
		OE = 1, $V_{DDO} = 1.8V \pm 0.2V$, Outputs Unloaded			5	mA
		OE = 1, $V_{DDO} = 1.5V \pm 0.15V$, Outputs Unloaded			5	mA

Table 4B. Power Supply DC Characteristics, $V_{DD} = 2.5V \pm 5\%$, $V_{DDO} = 2.5V \pm 5\%$ or $1.8V \pm 0.2V$ or $1.5V \pm 0.15V$, $T_A = -40^\circ\text{C}$ to 85°C

Symbol	Parameter	Test Conditions	Minimum	Typical	Maximum	Units
V_{DD}	Power Supply Voltage		2.375	2.5	2.625	V
V_{DDO}	Output Supply Current		2.375	2.5	2.625	V
			1.6	1.8	2	V
			1.35	1.5	1.65	V
I_{DD}	Power Supply Current	OE = 0			38	mA
I_{DDO}	Output Supply Current	OE = 1, $V_{DDO} = 2.5V \pm 5\%$, Outputs Unloaded			5	mA
		OE = 1, $V_{DDO} = 1.8V \pm 0.2V$, Outputs Unloaded			5	mA
		OE = 1, $V_{DDO} = 1.5V \pm 0.15V$, Outputs Unloaded			5	mA

Table 4C. LVCMOS/LVTTL DC Characteristics, $T_A = -40^\circ\text{C}$ to 85°C

Symbol	Parameter	Test Conditions	Minimum	Typical	Maximum	Units
V_{IH}	Input High Voltage	$V_{DD} = 3.3V \pm 5\%$	2		$V_{DD} + 0.3$	V
		$V_{DD} = 2.5V \pm 5\%$	1.7		$V_{DD} + 0.3$	V
V_{IL}	Input Low Voltage	$V_{DD} = 3.3V \pm 5\%$	-0.3		0.8	V
		$V_{DD} = 2.5V \pm 5\%$	-0.3		0.7	V
I_{IH}	Input High Current	OE, SEL[1:0] $V_{DD} = V_{IN} = 3.465V$			150	μA
I_{IL}	Input Low Current	OE, SEL[1:0] $V_{DD} = 3.465V, V_{IN} = 0V$	-5			μA
V_{OH}	Output High Voltage; NOTE 1	$V_{DDO} = 3.3V \pm 5\%$	2.6			V
		$V_{DDO} = 2.5V \pm 5\%$	1.8			V
		$V_{DDO} = 1.8V \pm 0.2V$	1.2			V
		$V_{DDO} = 1.5V \pm 0.15V$	0.97			V
V_{OL}	Output Low Voltage; NOTE 1	$V_{DDO} = 3.3V \pm 5\%$ or $2.5V \pm 5\%$			0.5	V
		$V_{DDO} = 1.8V \pm 0.2V$			0.4	V
		$V_{DDO} = 1.5V \pm 0.15V$			0.37	V

NOTE 1: Outputs terminated with 50Ω to $V_{DDO}/2$. See Parameter Measurement Information, *Output Load Test Circuit diagrams*.

Table 4D. Differential DC Characteristics, $V_{DD} = 3.3V \pm 5\%$ or $2.5V \pm 5\%$, $T_A = -40^\circ C$ to $85^\circ C$

Symbol	Parameter	Test Conditions	Minimum	Typical	Maximum	Units
I_{IH}	Input High Current	CLK[0:1], nCLK[0:1] $V_{DD} = V_{IN} = 3.465V$ or $2.625V$			150	μA
I_{IL}	Input Low Current	CLK[0:1] $V_{DD} = 3.465V$ or $2.625V$, $V_{IN} = 0V$	-5			μA
		nCLK[0:1] $V_{DD} = 3.465V$ or $2.625V$, $V_{IN} = 0V$	-150			μA
V_{PP}	Peak-to-Peak Input Voltage; NOTE 1		0.15		1.3	V
V_{CMR}	Common Mode Input Voltage; NOTE 1, 2		0.5		$V_{DD} - 0.85$	V

NOTE 1: V_{IL} should not be less than $-0.3V$.

NOTE 2. Common mode voltage is defined at the crosspoint.

Table 5. Crystal Characteristics

Parameter	Test Conditions	Minimum	Typical	Maximum	Units
Mode of Oscillation		Fundamental			
Frequency		10		40	MHz
Equivalent Series Resistance (ESR)				50	Ω
Shunt Capacitance				7	pF

NOTE: Characterized using a 12pF parallel resonant crystal.

AC Electrical Characteristics

Table 6. AC Characteristics, $V_{DD} = 3.3V \pm 5\%$, $V_{DDO} = 3.3V \pm 5\%$ or $2.5V \pm 5\%$ or $1.8V \pm 0.2V$ or $1.5V \pm 0.15V$, $T_A = -40^\circ C$ to $85^\circ C$

Symbol	Parameter		Test Conditions	Minimum	Typical	Maximum	Units
f_{OUT}	Output Frequency	Using External Crystal		10		40	MHz
		Using External Clock Source				200	MHz
$t_{sk(o)}$	Output Skew; NOTE 1, 2		$V_{DDO} = 3.3V \pm 5\%$		10	50	ps
			$V_{DDO} = 2.5V \pm 5\%$		10	50	ps
			$V_{DDO} = 1.8V \pm 0.2V$		10	55	ps
			$V_{DDO} = 1.5V \pm 0.15V$		15	75	ps
t_{jit}	Buffer Additive Phase Jitter; refer to Additive Phase Jitter Section; NOTE 3, $f_{OUT} = 125MHz$, Integration Range: 12kHz - 20MHz	Input Clock from CLK0, nCLK0 or CLK1, nCLK1	$V_{DDO} = 3.3V \pm 5\%$		0.24	0.35	ps
			$V_{DDO} = 2.5V \pm 5\%$		0.29	0.39	ps
			$V_{DDO} = 1.8V \pm 0.2V$		0.32	0.43	ps
			$V_{DDO} = 1.5V \pm 0.15V$		0.37	0.66	ps
$t_{jit(\emptyset)}$	RMS Phase Jitter; NOTE 3, Integration Range: 12kHz - 5MHz	Input Clock from 25MHz Crystal	$V_{DDO} = 3.3V \pm 5\%$		0.20	0.27	ps
			$V_{DDO} = 2.5V \pm 5\%$		0.23	0.29	ps
			$V_{DDO} = 1.8V \pm 0.2V$		0.26	0.37	ps
			$V_{DDO} = 1.5V \pm 0.15V$		0.33	0.63	ps
t_R / t_F	Output Rise/Fall Time	$V_{DDO} = 3.3V \pm 5\%$	20% to 80%	150		450	ps
		$V_{DDO} = 2.5V \pm 5\%$	20% to 80%	200		500	ps
		$V_{DDO} = 1.8V \pm 0.2V$	20% to 80%	200		800	ps
		$V_{DDO} = 1.5V \pm 0.15V$	20% to 80%	250		1000	ps
odc	Output Duty Cycle	$V_{DDO} = 3.3V \pm 5\%$	$f_{OUT} \leq 156.25MHz$	44		56	%
		$V_{DDO} = 2.5V \pm 5\%$		40		60	%
		$V_{DDO} = 1.8V \pm 0.2V$		40		60	%
		$V_{DDO} = 1.5V \pm 0.15V$		40		60	%
MUX_ISOLATION	MUX Isolation; NOTE 3		155.52MHz		65		dB

NOTE: Electrical parameters are guaranteed over the specified ambient operating temperature range, which is established when the device is mounted in a test socket with maintained transverse airflow greater than 500 lfpm. The device will meet specifications after thermal equilibrium has been reached under these conditions.

All parameters measured at $f \leq f_{OUT}$ unless noted otherwise.

NOTE 1: Defined as skew between outputs at the same supply voltage and with equal load conditions. Measured at $V_{DDO}/2$.

NOTE 2: This parameter is defined in accordance with JEDEC Standard 65.

NOTE 3: These parameters are guaranteed by characterization. Not tested in production.

Typical Phase Noise at 25MHz (3.3V)

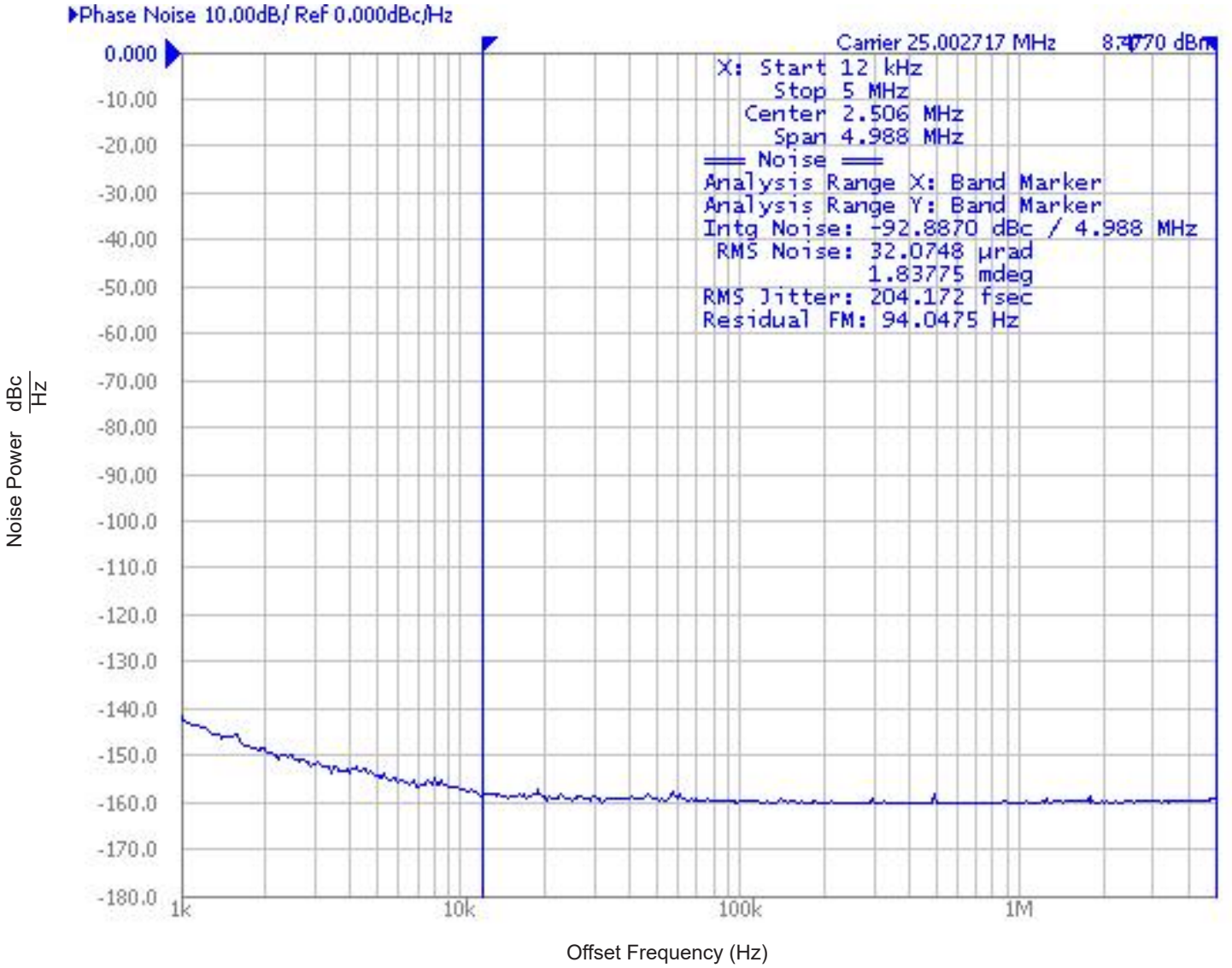

Additive Phase Jitter (3.3V)

The spectral purity in a band at a specific offset from the fundamental compared to the power of the fundamental is called the **dBc Phase Noise**. This value is normally expressed using a Phase noise plot and is most often the specified plot in many applications. Phase noise is defined as the ratio of the noise power present in a 1Hz band at a specified offset from the fundamental frequency to the power value of the fundamental. This ratio is expressed in decibels (dBm) or a ratio

of the power in the 1Hz band to the power in the fundamental. When the required offset is specified, the phase noise is called a **dBc** value, which simply means dBm at a specified offset from the fundamental. By investigating jitter in the frequency domain, we get a better understanding of its effects on the desired application over the entire time record of the signal. It is mathematically possible to calculate an expected bit error rate given a phase noise plot.

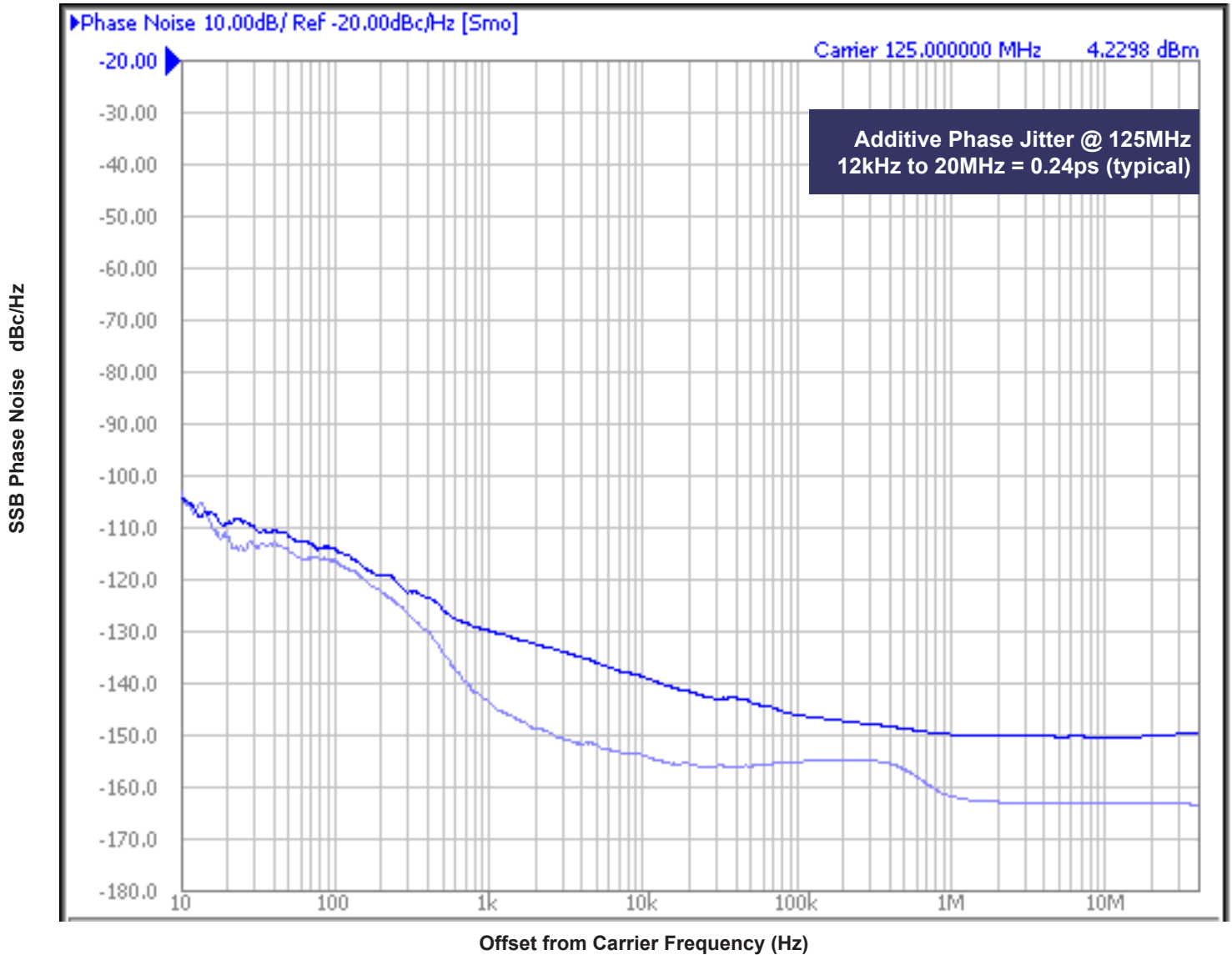

As with most timing specifications, phase noise measurements has issues relating to the limitations of the equipment. Often the noise floor of the equipment is higher than the noise floor of the device. The phase noise is dependent on the input source and measurement

equipment.

The signal generator used is, "Rohde & Schwarz SMA100A, measured with Agilent 5052A".

Parameter Measurement Information

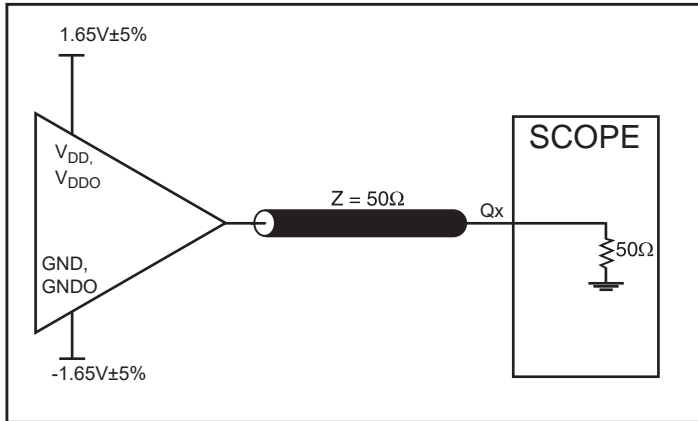

3.3V Core/3.3V Output Load AC Test Circuit

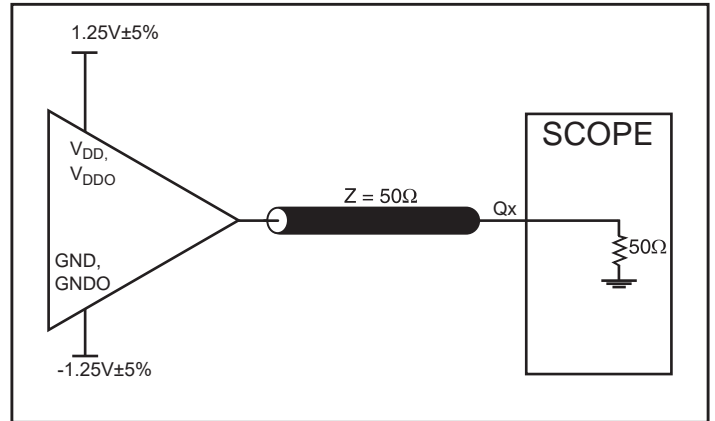

2.5V Core/2.5V Output Load AC Test Circuit

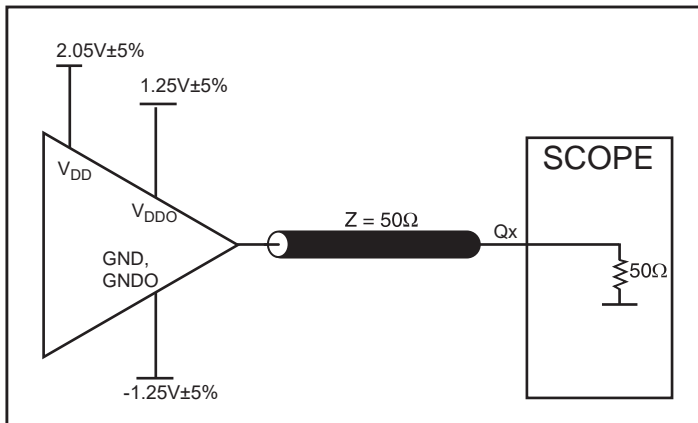

3.3V Core/2.5V Output Load AC Test Circuit

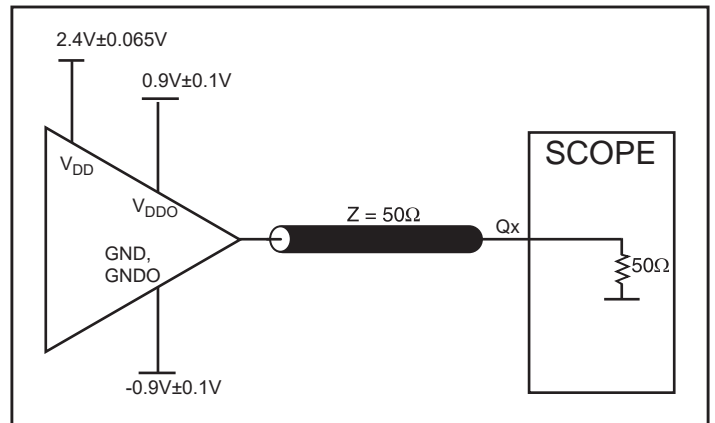

3.3V Core/1.8V Output Load AC Test Circuit

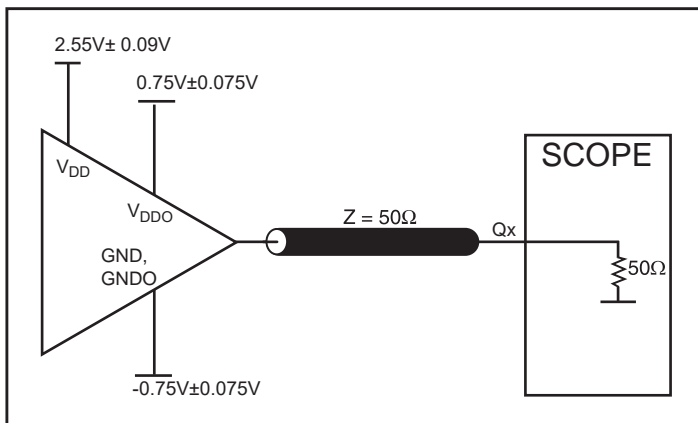

3.3V Core/1.5V Output Load AC Test Circuit

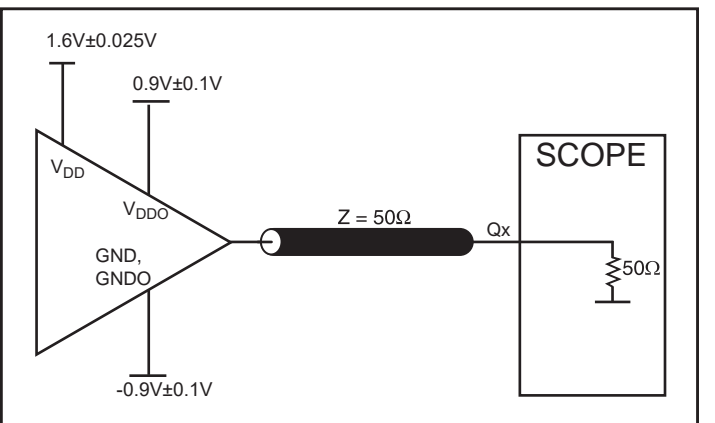

2.5V Core/1.8V Output Load AC Test Circuit

Parameter Measurement Information, continued

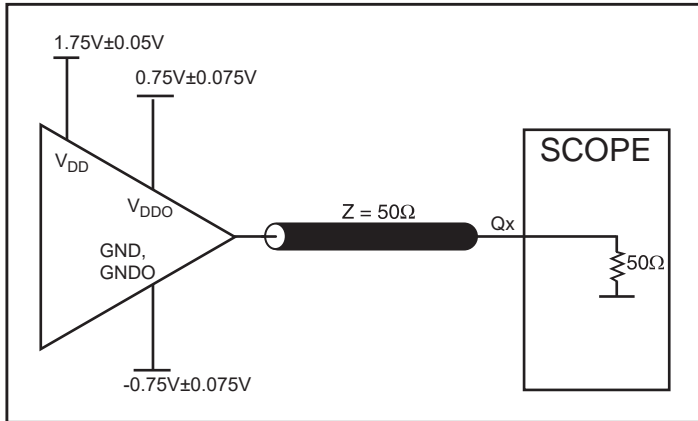

2.5V Core/1.5V Output Load AC Test Circuit

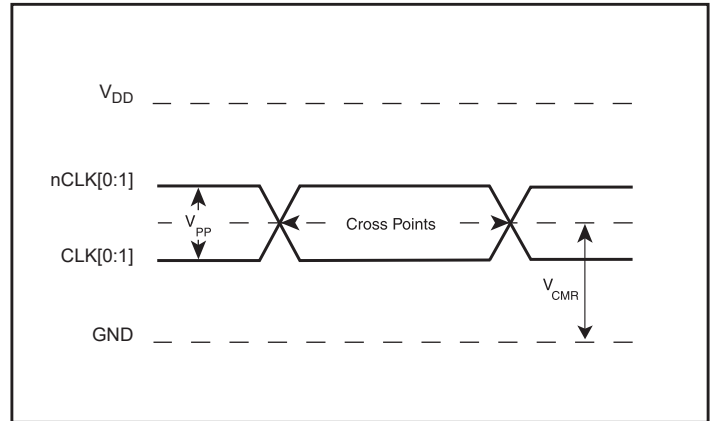

Differential Input Level

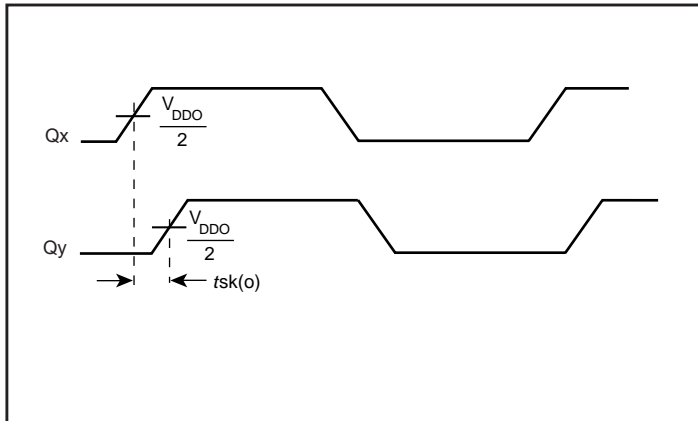

Output Skew

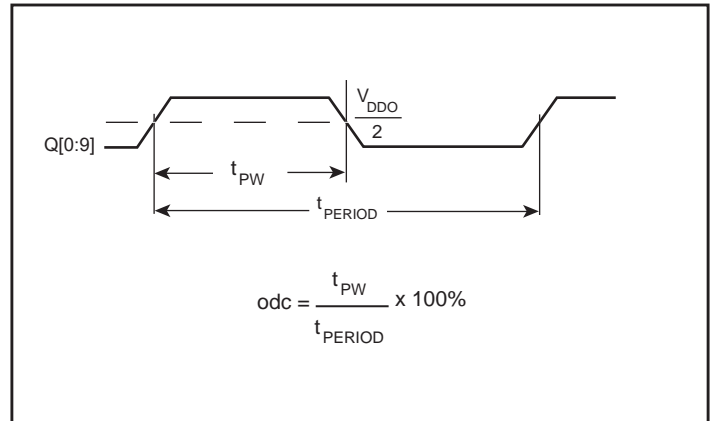

Output Duty Cycle/Pulse Width/Period

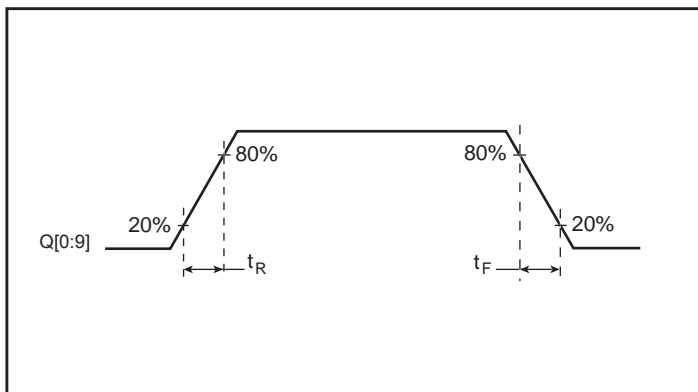

Output Rise/Fall Time

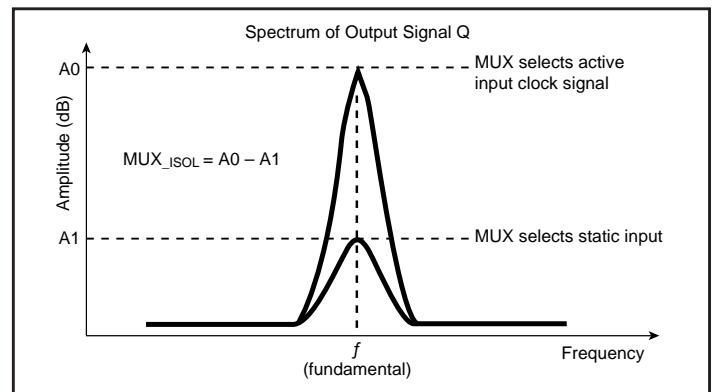

MUX Isolation

Parameter Measurement Information, continued

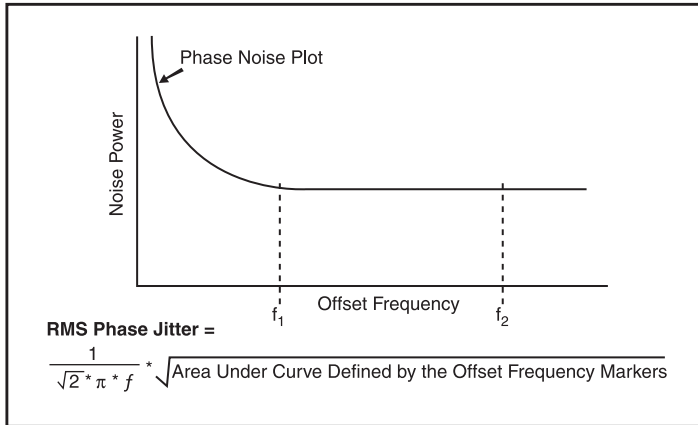

RMS Phase Jitter

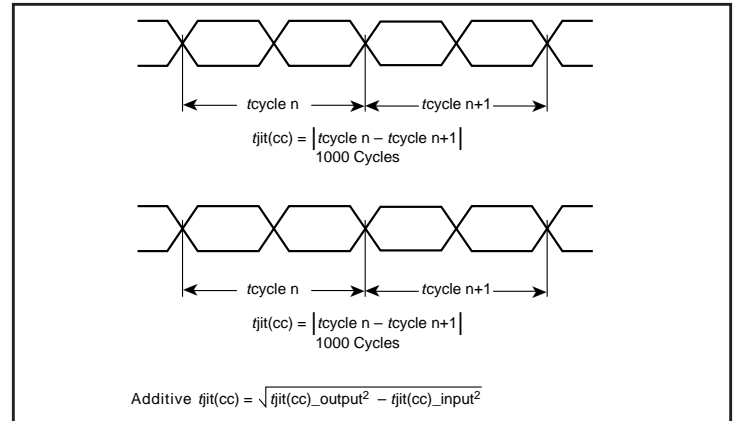

Additive Phase Jitter

Applications Information

Recommendations for Unused Input and Output Pins

Inputs:

CLK/nCLK Inputs

For applications not requiring the use of the differential input, both CLK and nCLK can be left floating. Though not required, but for additional protection, a 1kΩ resistor can be tied from CLK to ground.

Crystal Inputs

For applications not requiring the use of the crystal oscillator input, both XTAL_IN and XTAL_OUT can be left floating. Though not required, but for additional protection, a 1kΩ resistor can be tied from XTAL_IN to ground.

LVC MOS Control Pins

All control pins have internal pulldowns; additional resistance is not required but can be added for additional protection. A 1kΩ resistor can be used.

Outputs:

LVC MOS Outputs

All unused LVC MOS outputs can be left floating. We recommend that there is no trace attached.

Wiring the Differential Input to Accept Single-Ended Levels

Figure 2 shows how a differential input can be wired to accept single ended levels. The reference voltage $V_{REF} = V_{DD}/2$ is generated by the bias resistors R1 and R2. The bypass capacitor (C1) is used to help filter noise on the DC bias. This bias circuit should be located as close to the input pin as possible. The ratio of R1 and R2 might need to be adjusted to position the V_{REF} in the center of the input voltage swing. For example, if the input clock swing is 2.5V and $V_{DD} = 3.3V$, R1 and R2 value should be adjusted to set V_{REF} at 1.25V. The values below are for when both the single ended swing and V_{DD} are at the same voltage. This configuration requires that the sum of the output impedance of the driver (R_o) and the series resistance (R_s) equals the transmission line impedance. In addition, matched termination at the input will attenuate the signal in half. This can be done in one of two ways. First, R3 and R4 in parallel should equal the transmission

line impedance. For most 50Ω applications, R3 and R4 can be 100Ω. The values of the resistors can be increased to reduce the loading for slower and weaker LVCMOS driver. When using single-ended signaling, the noise rejection benefits of differential signaling are reduced. Even though the differential input can handle full rail LVCMOS signaling, it is recommended that the amplitude be reduced. The datasheet specifies a lower differential amplitude, however this only applies to differential signals. For single-ended applications, the swing can be larger, however V_{IL} cannot be less than -0.3V and V_{IH} cannot be more than $V_{DD} + 0.3V$. Though some of the recommended components might not be used, the pads should be placed in the layout. They can be utilized for debugging purposes. The datasheet specifications are characterized and guaranteed by using a differential signal.

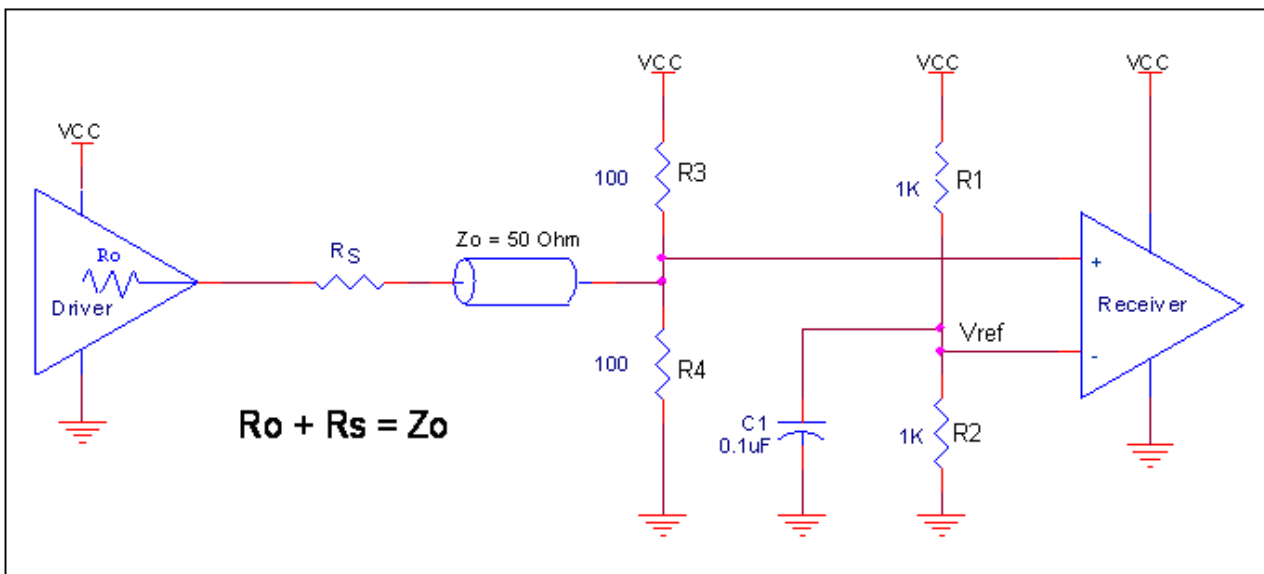

Figure 2. Recommended Schematic for Wiring a Differential Input to Accept Single-ended Levels

Crystal Input Interface

The IDT8L3010I has been characterized with 12pF parallel resonant crystals. The capacitor values, C1 and C2, shown in Figure 3 below were determined using an 12pF parallel resonant crystal and were chosen to minimize the ppm error. The optimum C1 and C2 values can be slightly adjusted for different board layouts.

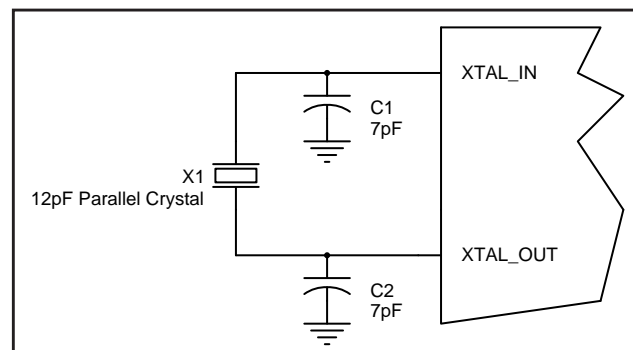

Figure 3. Crystal Input Interface

Overdriving the XTAL Interface

The XTAL_IN input can be overdriven by an LVCMOS driver or by one side of a differential driver through an AC coupling capacitor. The XTAL_OUT pin can be left floating. The amplitude of the input signal should be between 500mV and 1.8V and the slew rate should not be less than 0.2V/nS. For 3.3V LVCMOS inputs, the amplitude must be reduced from full swing to at least half the swing in order to prevent signal interference with the power rail and to reduce internal noise. *Figure 4A* shows an example of the interface diagram for a high speed 3.3V LVCMOS driver. This configuration requires that the sum of the output impedance of the driver (R_o) and the series resistance (R_s) equals the transmission line impedance. In addition, matched termination at the crystal input will attenuate the signal in half. This

can be done in one of two ways. First, R_1 and R_2 in parallel should equal the transmission line impedance. For most 50Ω applications, R_1 and R_2 can be 100Ω. This can also be accomplished by removing R_1 and changing R_2 to 50Ω. The values of the resistors can be increased to reduce the loading for a slower and weaker LVCMOS driver. *Figure 4B* shows an example of the interface diagram for an LVPECL driver. This is a standard LVPECL termination with one side of the driver feeding the XTAL_IN input. It is recommended that all components in the schematics be placed in the layout. Though some components might not be used, they can be utilized for debugging purposes. The datasheet specifications are characterized and guaranteed by using a quartz crystal as the input.

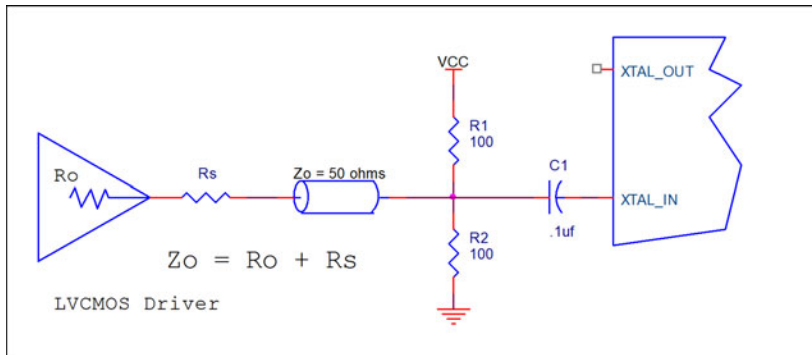

Figure 4A. General Diagram for LVCMOS Driver to XTAL Input Interface

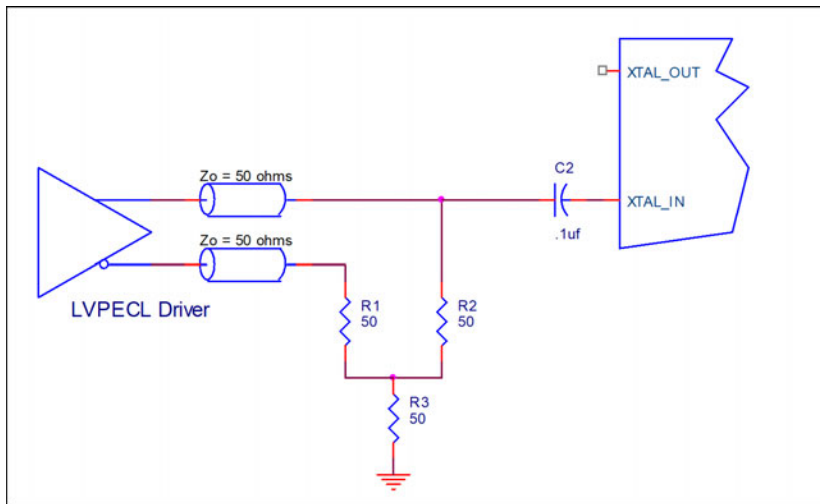

Figure 4B. General Diagram for LVPECL Driver to XTAL Input Interface

Differential Clock Input Interface

The CLK /nCLK accepts LVDS, LVPECL, HCSL and other differential signals. Both signals must meet the V_{PP} and V_{CMR} input requirements. *Figures 5A to 5D* show interface examples for the CLK /nCLK input with built-in 50Ω terminations driven by the most

common driver types. The input interfaces suggested here are examples only. If the driver is from another vendor, use their termination recommendation. Please consult with the vendor of the driver component to confirm the driver termination requirements.

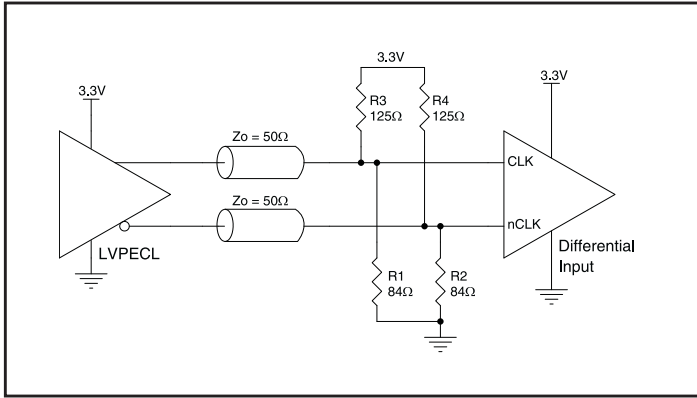

Figure 5A. CLK/nCLK Input Driven by a 3.3V LVPECL Driver

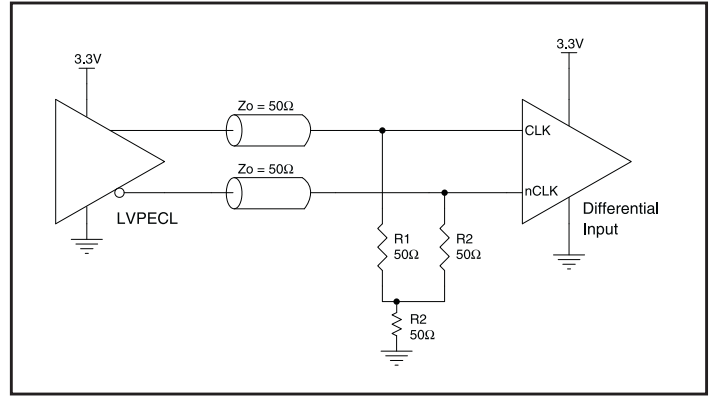

Figure 5B. CLK/nCLK Input Driven by a 3.3V LVPECL Driver

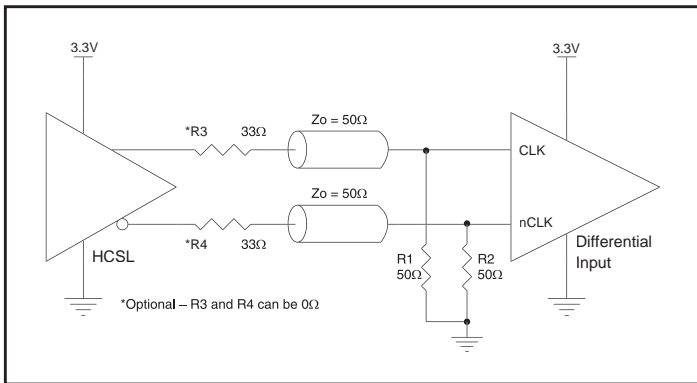

Figure 5C. CLK/nCLK Input Driven by a 3.3V HCSL Driver

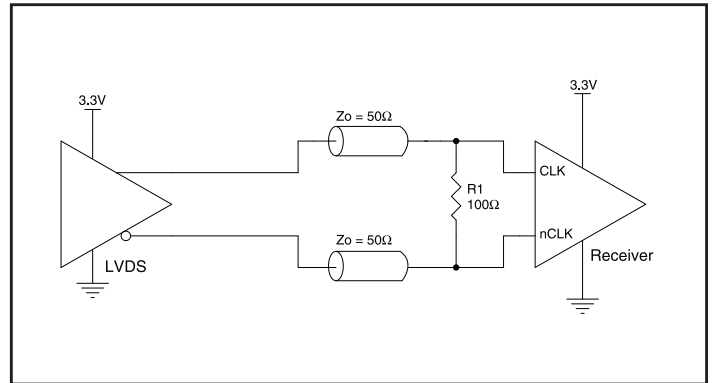

Figure 5D. CLK/nCLK Input Driven by a 3.3V LVDS Driver

VFQFN EPAD Thermal Release Path

In order to maximize both the removal of heat from the package and the electrical performance, a land pattern must be incorporated on the Printed Circuit Board (PCB) within the footprint of the package corresponding to the exposed metal pad or exposed heat slug on the package, as shown in *Figure 6*. The solderable area on the PCB, as defined by the solder mask, should be at least the same size/shape as the exposed pad/slug area on the package to maximize the thermal/electrical performance. Sufficient clearance should be designed on the PCB between the outer edges of the land pattern and the inner edges of pad pattern for the leads to avoid any shorts.

While the land pattern on the PCB provides a means of heat transfer and electrical grounding from the package to the board through a solder joint, thermal vias are necessary to effectively conduct from the surface of the PCB to the ground plane(s). The land pattern must be connected to ground through these vias. The vias act as “heat pipes”. The number of vias (i.e. “heat pipes”) are application specific

and dependent upon the package power dissipation as well as electrical conductivity requirements. Thus, thermal and electrical analysis and/or testing are recommended to determine the minimum number needed. Maximum thermal and electrical performance is achieved when an array of vias is incorporated in the land pattern. It is recommended to use as many vias connected to ground as possible. It is also recommended that the via diameter should be 12 to 13mils (0.30 to 0.33mm) with 1oz copper via barrel plating. This is desirable to avoid any solder wicking inside the via during the soldering process which may result in voids in solder between the exposed pad/slug and the thermal land. Precautions should be taken to eliminate any solder voids between the exposed heat slug and the land pattern. Note: These recommendations are to be used as a guideline only. For further information, please refer to the Application Note on the Surface Mount Assembly of Amkor’s Thermally/Electrically Enhance Leadframe Base Package, Amkor Technology.

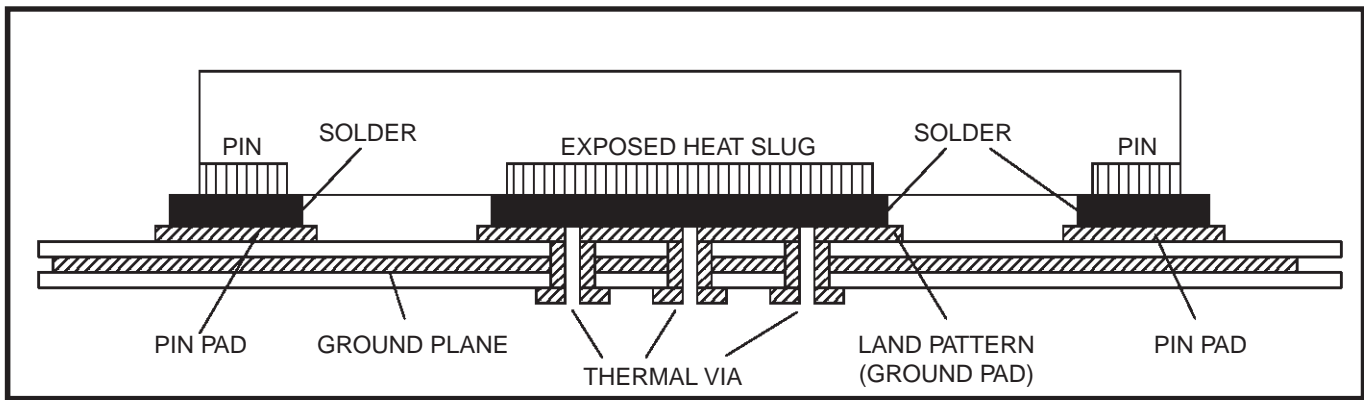

Figure 6. P.C. Assembly for Exposed Pad Thermal Release Path – Side View (drawing not to scale)

Power Considerations

This section provides information on power dissipation and junction temperature for the IDT8L3010I. Equations and example calculations are also provided.

1. Power Dissipation.

The total power dissipation for the IDT8L3010I is the sum of the core power plus the power dissipation in the load(s). The following is the power dissipation for $V_{DD} = 3.3V + 5\% = 3.465V$, which gives worst case results.

$$\text{Power (core)}_{MAX} = V_{DD_MAX} * I_{DD} = 3.465V * 38mA = \mathbf{131.67mW}$$

$$\text{Power (output)}_{MAX} = V_{DDO_MAX} * I_{DDO_MAX} = 3.465V * 5mA = \mathbf{17.325mW}$$

Total Static Power:

$$= \text{Power (core)}_{MAX} + \text{Power (output)}_{MAX} = 132mW + 17.325mW = \mathbf{148.995mW}$$

Dynamic Power Dissipation at F_{OUT} (200MHz)

$$\text{Total Power (} F_{OUT_MAX} \text{)} = [(C_{PD} * N) * \text{Frequency} * (V_{DDO})^2] = [(13pF * 10) * 200MHz * (3.465V)^2] = \mathbf{312mW}$$

N = number of outputs

Total Power

$$= \text{Static Power} + \text{Dynamic Power Dissipation}$$

$$= 148.995mW + 312mW$$

$$= \mathbf{460.995mW}$$

2. Junction Temperature.

Junction temperature, T_j , is the temperature at the junction of the bond wire and bond pad, and directly affects the reliability of the device. The maximum recommended junction temperature is 125°C. Limiting the internal transistor junction temperature, T_j , to 125°C ensures that the bond wire and bond pad temperature remains below 125°C.

$$\text{The equation for } T_j \text{ is as follows: } T_j = \theta_{JA} * Pd_{total} + T_A$$

$$T_j = \text{Junction Temperature}$$

$$\theta_{JA} = \text{Junction-to-Ambient Thermal Resistance}$$

$$Pd_{total} = \text{Total Device Power Dissipation (example calculation is in section 1 above)}$$

$$T_A = \text{Ambient Temperature}$$

In order to calculate junction temperature, the appropriate junction-to-ambient thermal resistance θ_{JA} must be used. Assuming no air flow and a multi-layer board, the appropriate value is 33.1°C/W per Table 7 below.

Therefore, T_j for an ambient temperature of 85°C with all outputs switching is:

$$85^\circ\text{C} + 0.461W * 33.1^\circ\text{C/W} = 100.3^\circ\text{C}. \text{ This is below the limit of } 125^\circ\text{C}.$$

This calculation is only an example. T_j will obviously vary depending on the number of loaded outputs, supply voltage, air flow and the type of board (multi-layer).

Table 7. Thermal Resistance θ_{JA} for 32 Lead VFQFN, Forced Convection

θ_{JA} by Velocity			
Meters per Second	0	1	3
Multi-Layer PCB, JEDEC Standard Test Boards	33.1°C/W	28.1°C/W	25.4°C/W

Reliability Information

Table 8. θ_{JA} vs. Air Flow Table for a 32 Lead VFQFN

θ_{JA} vs. Air Flow			
Meters per Second	0	1	3
Multi-Layer PCB, JEDEC Standard Test Boards	33.1°C/W	28.1°C/W	25.4°C/W

Transistor Count

The transistor count for IDT8L3010I is: 18,346

Package Outline Drawings

www.idt.com/document/psc/32-vfqfn-package-outline-drawing-50-x-50-x-090-mm-body-epad-315-x-315-mm-nlg32p1

Ordering Information

Table 9. Ordering Information

Part/Order Number	Marking	Package	Shipping Packaging	Temperature
8L3010ANLGI	IDT8L3010ANLGI	Lead-Free, 32 Lead VFQFN	Tray	-40°C to 85°C
8L3010ANLGI8	IDT8L3010ANLGI	Lead-Free, 32 Lead VFQFN	2500 Tape & Reel	-40°C to 85°C

NOTE: Parts that are ordered with an "G" suffix to the part number are the Pb-Free configuration and are RoHS compliant.

Revision History

Revision Date	Description of Change
November 30, 2018	Updated the description of Absolute Maximum Ratings Added Recommended Operating Conditions Updated the Package Outline Drawings ; however, no technical changes
January 12, 2012	Initial release.

IMPORTANT NOTICE AND DISCLAIMER

RENESAS ELECTRONICS CORPORATION AND ITS SUBSIDIARIES (“RENESAS”) PROVIDES TECHNICAL SPECIFICATIONS AND RELIABILITY DATA (INCLUDING DATASHEETS), DESIGN RESOURCES (INCLUDING REFERENCE DESIGNS), APPLICATION OR OTHER DESIGN ADVICE, WEB TOOLS, SAFETY INFORMATION, AND OTHER RESOURCES “AS IS” AND WITH ALL FAULTS, AND DISCLAIMS ALL WARRANTIES, EXPRESS OR IMPLIED, INCLUDING, WITHOUT LIMITATION, ANY IMPLIED WARRANTIES OF MERCHANTABILITY, FITNESS FOR A PARTICULAR PURPOSE, OR NON-INFRINGEMENT OF THIRD-PARTY INTELLECTUAL PROPERTY RIGHTS.

These resources are intended for developers who are designing with Renesas products. You are solely responsible for (1) selecting the appropriate products for your application, (2) designing, validating, and testing your application, and (3) ensuring your application meets applicable standards, and any other safety, security, or other requirements. These resources are subject to change without notice. Renesas grants you permission to use these resources only to develop an application that uses Renesas products. Other reproduction or use of these resources is strictly prohibited. No license is granted to any other Renesas intellectual property or to any third-party intellectual property. Renesas disclaims responsibility for, and you will fully indemnify Renesas and its representatives against, any claims, damages, costs, losses, or liabilities arising from your use of these resources. Renesas' products are provided only subject to Renesas' Terms and Conditions of Sale or other applicable terms agreed to in writing. No use of any Renesas resources expands or otherwise alters any applicable warranties or warranty disclaimers for these products.

(Disclaimer Rev.1.01)

Corporate Headquarters

TOYOSU FORESIA, 3-2-24 Toyosu,
Koto-ku, Tokyo 135-0061, Japan
www.renesas.com

Trademarks

Renesas and the Renesas logo are trademarks of Renesas Electronics Corporation. All trademarks and registered trademarks are the property of their respective owners.

Contact Information

For further information on a product, technology, the most up-to-date version of a document, or your nearest sales office, please visit www.renesas.com/contact-us/.