

## Two Output Differential Buffer for PCIe Gen1 & Gen2

ICS9DB102

### Description

The **ICS9DB102** zero-delay buffer supports PCI Express clocking requirements. The **ICS9DB102** is driven by a differential SRC output pair from an ICS CK410/CK505-compliant main clock. It attenuates jitter on the input clock and has a selectable PLL Band Width to maximize performance in systems with or without Spread-Spectrum clocking.

### Output Features

- 2 - 0.7V current mode differential output pairs (HCSL)

### Features/Benefits

- CLKREQ# pin for outputs 1 and 4/output enable for Express Card applications
- PLL or bypass mode/PLL can dejitter incoming clock
- Selectable PLL bandwidth/minimizes jitter peaking in downstream PLL's
- Spread Spectrum Compatible/tracks spreading input clock for low EMI
- SMBus Interface/unused outputs can be disabled
- Industrial temperature range available

### Key Specifications

- Cycle-to-cycle jitter < 35ps
- Output-to-output skew < 25ps

### Functional Block Diagram

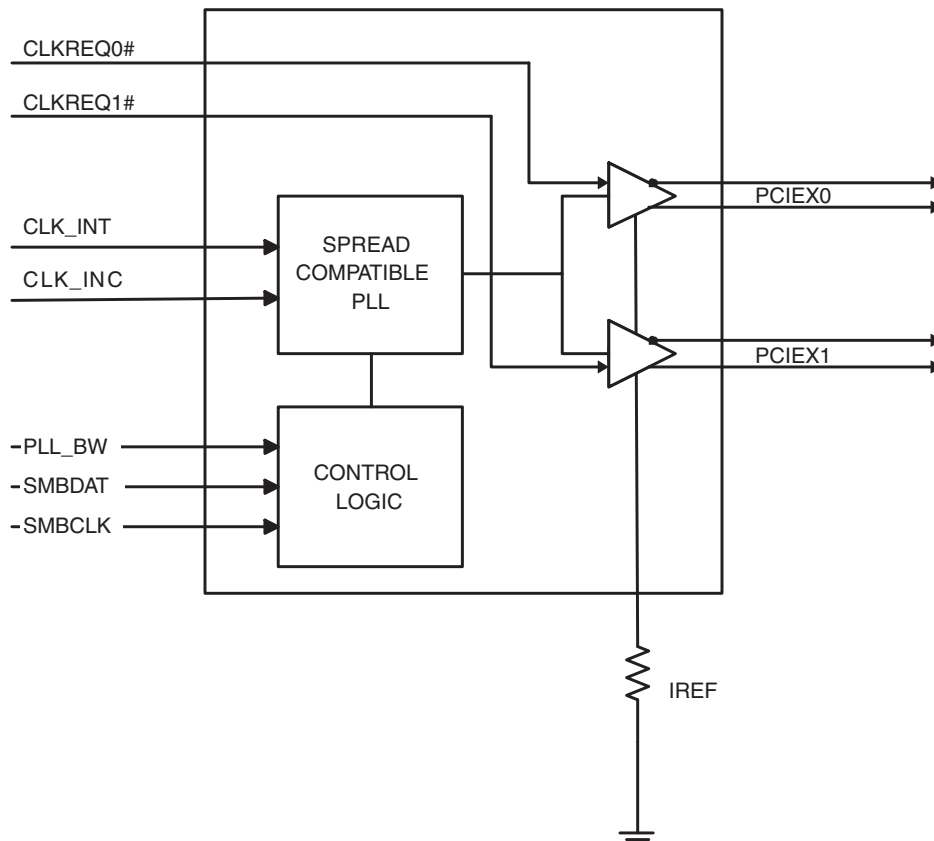

**ICS9DB102**  
Two Output Differential Buffer for PCIe Gen1 & Gen2

**Pin Configuration**

PLL_BW	1	<b>ICS9DB102</b>	20	VDDA
CLK_INT	2		19	GND A
CLK_INC	3		18	IREF
vCLKREQ0#	4		17	vCLKREQ1#
VDD	5		16	VDD
GND	6		15	GND
PCIEXT0	7		14	PCIEXT1
PCIEXC0	8		13	PCIEXC1
VDD	9		12	VDD
SMBDAT	10		11	SMBCLK

**Note:** Pins preceded by ' v ' have internal 120K ohm pull down resistors

**Power Groups**

Pin Number		Description
VDD	GND	
5,9,12,16	6,15	PCI Express Outputs
9	6	SMBUS
20	19	IREF
20	19	Analog VDD & GND for PLL core

**20-pin SSOP & TSSOP**

**Pin Description**

PIN #	PIN NAME	PIN TYPE	DESCRIPTION
1	PLL_BW	IN	3.3V input for selecting PLL Band Width 0 = low, 1= high
2	CLK_INT	IN	True Input for differential reference clock.
3	CLK_INC	IN	Complementary Input for differential reference clock.
4	vCLKREQ0#	IN	Output enable for PCI Express output pair 0. 0 = enabled, 1 =disabled
5	VDD	PWR	Power supply, nominal 3.3V
6	GND	PWR	Ground pin.
7	PCIEXT0	OUT	True clock of differential PCI_Express pair.
8	PCIEXC0	OUT	Complementary clock of differential PCI_Express pair.
9	VDD	PWR	Power supply, nominal 3.3V
10	SMBDAT	I/O	Data pin of SMBUS circuitry, 5V tolerant
11	SMBCLK	IN	Clock pin of SMBUS circuitry, 5V tolerant
12	VDD	PWR	Power supply, nominal 3.3V
13	PCIEXC1	OUT	Complementary clock of differential PCI_Express pair.
14	PCIEXT1	OUT	True clock of differential PCI_Express pair.
15	GND	PWR	Ground pin.
16	VDD	PWR	Power supply, nominal 3.3V
17	vCLKREQ1#	IN	Output enable for PCI Express output pair 1. 0 = enabled, 1 =disabled
18	IREF	OUT	This pin establishes the reference for the differential current-mode output pairs. It requires a fixed precision resistor to ground. 475ohm is the standard value for 100ohm differential impedance. Other impedances require different values. See data sheet.
19	GND A	PWR	Ground pin for the PLL core.
20	VDDA	PWR	3.3V power for the PLL core.

**Note:**  
Pins preceded by ' v ' have internal 120K ohm pull down resistors

## Absolute Max

Symbol	Parameter	Min	Max	Units
VDDA	3.3V Core Supply Voltage		$V_{DD} + 0.5V$	V
VDD	3.3V Output Supply Voltage	GND - 0.5	$V_{DD} + 0.5V$	V
Ts	Storage Temperature	-65	150	°C
Tcase	Case Temperature		115	°C
ESD_prot	Input ESD protection human body model	2000		V

## Electrical Characteristics - Input/Supply/Common Output Parameters

T<sub>A</sub> = Tambient; Supply Voltage V<sub>DD</sub> = 3.3 V +/-5%

PARAMETER	SYMBOL	CONDITIONS	MIN	TYP	MAX	UNITS	NOTES
Tambient	Tambcom	Commercial range	0		70	°C	1
	Tambind	Industrial range	-40		85	°C	1
Input High Voltage	V <sub>IH</sub>	3.3 V +/-5%	2		V <sub>DD</sub> + 0.3	V	1
Input Low Voltage	V <sub>IL</sub>	3.3 V +/-5%	V <sub>SS</sub> - 0.3		0.8	V	1
Input High Current	I <sub>IH</sub>	V <sub>IN</sub> = V <sub>DD</sub>	-5		5	uA	1
Input Low Current	I <sub>IL1</sub>	V <sub>IN</sub> = 0 V; Inputs with no pull-up resistors	-5			uA	1
	I <sub>IL2</sub>	V <sub>IN</sub> = 0 V; Inputs with pull-up resistors	-200			uA	1
Operating Supply Current	I <sub>DD3.30P</sub>	Full Active, C <sub>L</sub> = Full load;		75	100	mA	1
		all differential pairs tri-stated		27	50	mA	1
Input Frequency <sup>3</sup>	F <sub>i</sub>	V <sub>DD</sub> = 3.3 V	99	100	101	MHz	1
Pin Inductance <sup>1</sup>	L <sub>pin</sub>				7	nH	1
Input Capacitance <sup>1</sup>	C <sub>IN</sub>	Logic Inputs			5	pF	1
	C <sub>OUT</sub>	Output pin capacitance			4.5	pF	1
Clock Stabilization <sup>1,2</sup>	T <sub>STAB</sub>	From V <sub>DD</sub> Power-Up to 1st clock			1.8	ms	1
Modulation Frequency		Triangular Modulation	30		33	KHz	1
Spread Spectrum Modulation Frequency	f <sub>MOD</sub>	Lexmark Modulation	25		45	KHz	1
OE# Latency	t <sub>LATO#</sub>	DIF start after OE# assertion DIF stop after OE# deassertion	1		3	cycles	1,2
PLL Bandwidth	BW	PLL Bandwidth when PLL_BW=0	400	500	1000	KHz	1
		PLL Bandwidth when PLL_BW=1	2	2.5	3	MHz	1
SMBus Voltage	V <sub>DD</sub>		2.7		5.5	V	1
Low-level Output Voltage	V <sub>OL</sub> SMBUS	@ I <sub>PULLUP</sub>			0.4	V	1
Current sinking at V <sub>OL</sub> = 0.4 V	I <sub>PULLUP</sub>	SMBus SDATA pin	4			mA	1
SCLK/SDATA Clock/Data Rise Time	T <sub>RI2C</sub>	(Max V <sub>IL</sub> - 0.15) to (Min V <sub>IH</sub> + 0.15)			1000	ns	1
SCLK/SDATA Clock/Data Fall Time	T <sub>FI2C</sub>	(Min V <sub>IH</sub> + 0.15) to (Max V <sub>IL</sub> - 0.15)			300	ns	1

<sup>1</sup>Guaranteed by design and characterization, not 100% tested in production.

<sup>2</sup>Time from deassertion until outputs are >200mV

**Electrical Characteristics - PCIEX 0.7V Current Mode Differential Pair**
 $T_A = T_{\text{ambient}}$ ;  $V_{DD} = 3.3 \text{ V } +/-5\%$ ;  $C_L = 2\text{pF}$ ,  $R_S = 33.2\Omega$ ,  $R_P = 49.9\Omega$ ,  $I_{REF} = 475\Omega$ 

PARAMETER	SYMBOL	CONDITIONS	MIN	TYP	MAX	UNITS	NOTES
Current Source Output Impedance	Zo	$V_O = V_x$	3000			$\Omega$	1
Voltage High	VHigh	Statistical measurement on single ended signal using	660		850	mV	1,3
Voltage Low	VLow		-150		150		
Max Voltage	Vovs	Measurement on single ended signal using absolute value.			1150	mV	1,3
Min Voltage	Vuds		-300				
Crossing Voltage (abs)	Vcross(abs)		250	350	550	mV	1,3
Crossing Voltage (var)	d-Vcross	Variation of crossing over all edges		12	140	mV	1,3
Long Accuracy	ppm	see Tperiod min-max values			0	ppm	1,2
Average period	Tperiod	100.00MHz nominal	9.9970		10.0030	ns	2
		100.00MHz spread	9.9970		10.0533	ns	2
Absolute min period	Tabmin	100.00MHz nominal/spread	9.8720			ns	1,2
Rise Time	t <sub>r</sub>	$V_{OL} = 0.175\text{V}$ , $V_{OH} = 0.525\text{V}$	175		700	ps	1
Fall Time	t <sub>f</sub>	$V_{OH} = 0.525\text{V}$ $V_{OL} = 0.175\text{V}$	175		700	ps	1
Rise Time Variation	d-t <sub>r</sub>			30	125	ps	1
Fall Time Variation	d-t <sub>f</sub>			30	125	ps	1
Input to Output Delay	t <sub>pd</sub>	PLL Mode.	0		150	ps	1
	t <sub>pdbyb</sub>	Bypass mode	3.7		4.2	ns	1
Duty Cycle	d <sub>t3</sub>	Measurement from differential waveform	45		55	%	1
Output-to-Output Skew	t <sub>sk3</sub>	$V_T = 50\%$			25	ps	1
Jitter, Cycle to cycle	t <sub>jyc-cyc</sub>	PLL mode. Measurement from differential waveform			35	ps	1
	t <sub>jyc-cycbyp</sub>	Additive Jitter in Bypass Mode			30	ps	1

<sup>1</sup>Guaranteed by design, not 100% tested in production.

<sup>2</sup>The 9DB102 does not add a ppm error to the input clock

<sup>3</sup> $I_{REF} = V_{DD}/(3 \times R_R)$ . For  $R_R = 475\Omega$  (1%),  $I_{REF} = 2.32\text{mA}$ .  $I_{OH} = 6 \times I_{REF}$  and  $V_{OH} = 0.7\text{V}$  @  $Z_O = 50\Omega$ .

## Electrical Characteristics - PLL Parameters

$T_A$  = Tambient; Supply Voltage  $V_{DD} = 3.3\text{ V} \pm 5\%$

Group	Parameter	Description	Min	Typ	Max	Units	Notes
PLL Jitter Peaking	$j_{\text{peak-hibw}}$	(PLL_BW = 1)	0	1	2.5	dB	1,4
PLL Jitter Peaking	$j_{\text{peak-lobw}}$	(PLL_BW = 0)	0	1	2	dB	1,4
PLL Bandwidth	$p_{\text{ll\_HIBW}}$	(PLL_BW = 1)	2	2.5	3	MHz	1,5
PLL Bandwidth	$p_{\text{ll\_LOBW}}$	(PLL_BW = 0)	0.4	0.5	1	MHz	1,5
Jitter, Phase	$t_{\text{jphasePLL}}$	PCIe Gen 1 phase jitter (1.5 - 22 MHz)		40	108	ps	1,2,3
		PCIe Gen 2 jitter (8-16 MHz, 5-16 MHz) Hi-Band >1.5MHz (PLL_BW=1)		2.7	3.1	ps rms	1,2,3
		PCIe Gen 2 jitter (8-16 MHz, 5-16 MHz) Hi-Band >1.5MHz (PLL_BW=0)		2.2	3.1	ps rms	1,2,3
		PCIe Gen 2 jitter (8-16 MHz, 5-16 MHz) Lo-Band <1.5MHz		1.3	3	ps rms	1,2,3

### NOTES:

1. Guaranteed by design and characterization, not 100% tested in production.
2. See <http://www.pcisig.com> for complete specs
3. Device driven by 932S421BGLF or equivalent
4. Measured as maximum pass band gain. At frequencies within the loop BW, highest point of magnification is called PLL jitter peaking.
5. Measured at 3 db down or half power point.

SRC Reference Clock			
Common Recommendations for Differential Routing	Dimension or Value	Unit	Figure
L1 length, route as non-coupled 50ohm trace	0.5 max	inch	1
L2 length, route as non-coupled 50ohm trace	0.2 max	inch	1
L3 length, route as non-coupled 50ohm trace	0.2 max	inch	1
Rs	33	ohm	1
Rt	49.9	ohm	1

Down Device Differential Routing			
L4 length, route as coupled microstrip 100ohm differential trace	2 min to 16 max	inch	1
L4 length, route as coupled stripline 100ohm differential trace	1.8 min to 14.4 max	inch	1

Differential Routing to PCI Express Connector			
L4 length, route as coupled microstrip 100ohm differential trace	0.25 to 14 max	inch	2
L4 length, route as coupled stripline 100ohm differential trace	0.225 min to 12.6 max	inch	2

Figure 1: Down Device Routing

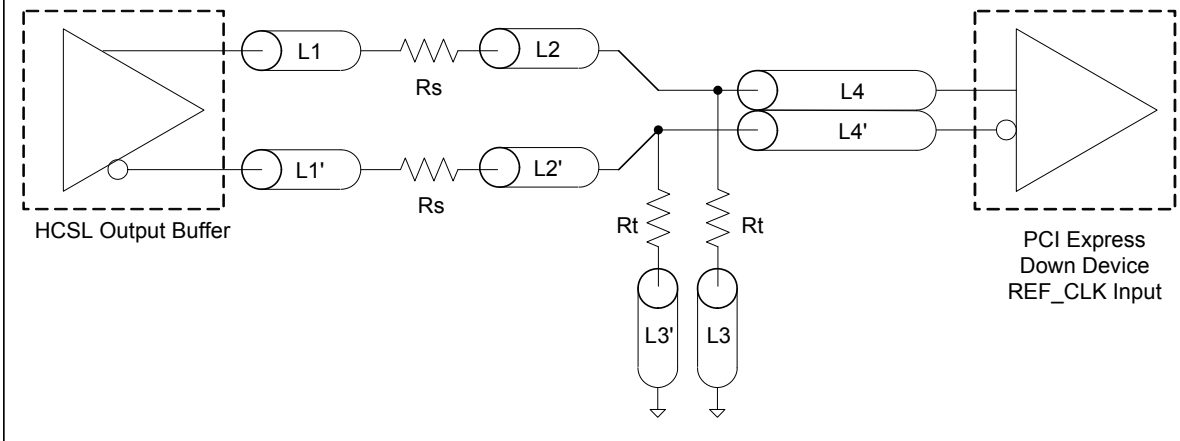
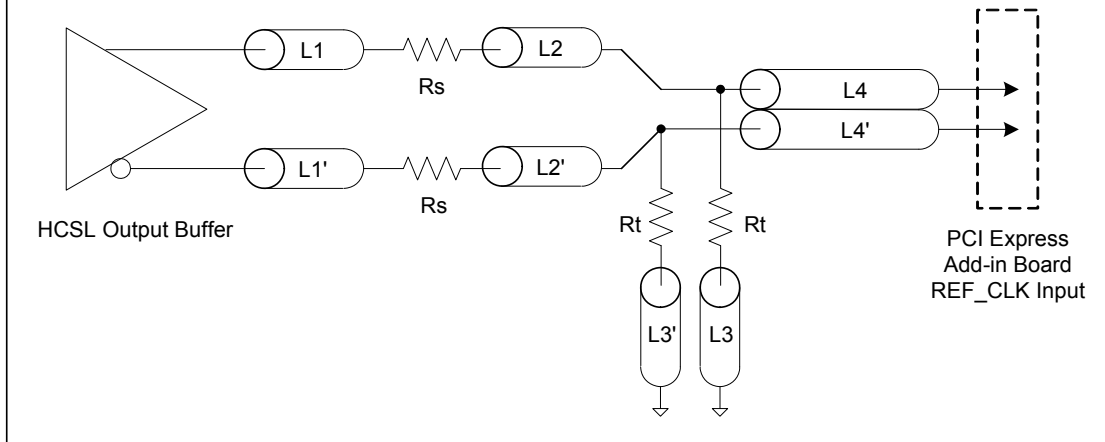

Figure 2: PCI Express Connector Routing



Alternative Termination for LVDS and other Common Differential Signals (figure 3)

Vdiff	Vp-p	Vcm	R1	R2	R3	R4	Note
0.45v	0.22v	1.08	33	150	100	100	
0.58	0.28	0.6	33	78.7	137	100	
0.80	0.40	0.6	33	78.7	none	100	ICS874003i-02 input compatible
0.60	0.3	1.2	33	174	140	100	Standard LVDS

R1a = R1b = R1

R2a = R2b = R2

Figure 3

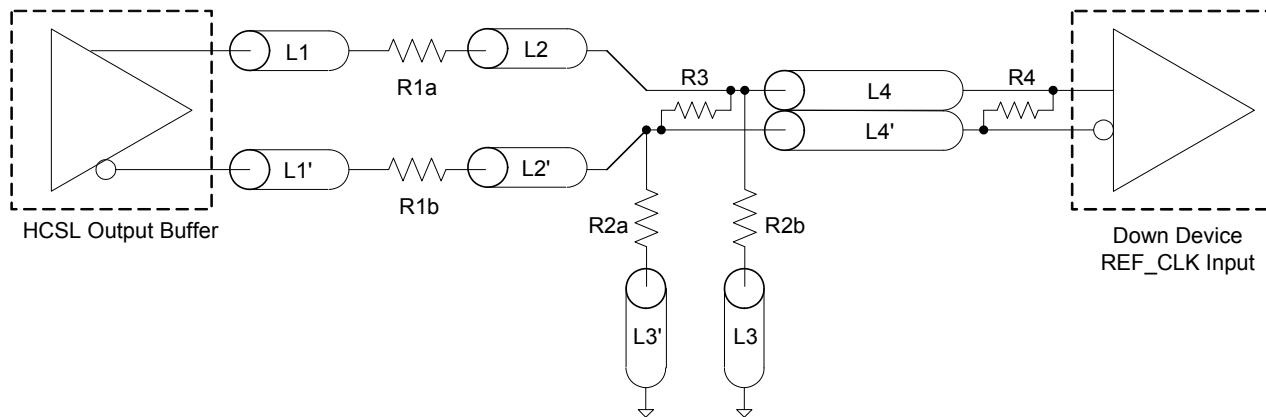

Cable Connected AC Coupled Application (figure 4)

Component	Value	Note
R5a, R5b	8.2K 5%	
R6a, R6b	1K 5%	
Cc	0.1 $\mu$ F	
Vcm	0.350 volts	

Figure 4

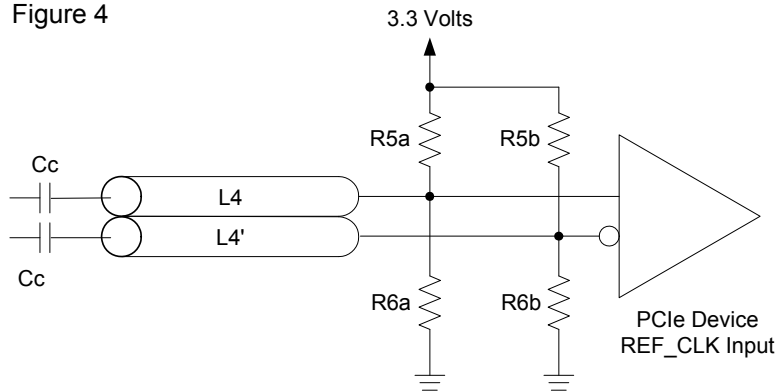

## General SMBus serial interface information for the ICS9DB102

### How to Write:

- Controller (host) sends a start bit.
- Controller (host) sends the write address D4<sub>(h)</sub>
- IDT clock will **acknowledge**
- Controller (host) sends the beginning byte location = N
- IDT clock will **acknowledge**
- Controller (host) sends the data byte count = X
- IDT clock will **acknowledge**
- Controller (host) starts sending **Byte N through Byte N + X - 1**
- IDT clock will **acknowledge** each byte **one at a time**
- Controller (host) sends a Stop bit

### How to Read:

- Controller (host) will send start bit.
- Controller (host) sends the write address D4<sub>(h)</sub>
- IDT clock will **acknowledge**
- Controller (host) sends the beginning byte location = N
- IDT clock will **acknowledge**
- Controller (host) will send a separate start bit.
- Controller (host) sends the read address D5<sub>(h)</sub>
- IDT clock will **acknowledge**
- IDT clock will send the data byte count = X
- IDT clock sends **Byte N + X - 1**
- IDT clock sends **Byte 0 through byte X (if X<sub>(h)</sub> was written to byte 8)**.
- Controller (host) will need to acknowledge each byte
- Controller (host) will send a not acknowledge bit
- Controller (host) will send a stop bit

Index Block Write Operation		
Controller (Host)		IDT (Slave/Receiver)
T	starT bit	
Slave Address D4 <sub>(h)</sub>		
WR	WRite	
		ACK
Beginning Byte = N		
		ACK
Data Byte Count = X		
		ACK
Beginning Byte N		X Byte
◊		
◊		
◊		
Byte N + X - 1		
		ACK
P	stoP bit	

Index Block Read Operation		
Controller (Host)		IDT (Slave/Receiver)
T	starT bit	
Slave Address D4 <sub>(h)</sub>		
WR	WRite	
		ACK
Beginning Byte = N		
		ACK
RT	Repeat starT	
Slave Address D5 <sub>(h)</sub>		
RD	ReaD	
		ACK
		Data Byte Count = X
ACK		
		X Byte
ACK		
◊		
◊		
◊		
		Byte N + X - 1
N	Not acknowledge	
P	stoP bit	



SMBus Table: Device Control Register, READ/WRITE ADDRESS (D4/D5)

Byte 0		Pin #	Name	Control Function	Type	0	1	PWD
Bit 7	-		SW_EN	Enables SMBus Control	RW	Functions controlled by SMBus registers	Functions controlled by device pins	1
Bit 6	-		RESERVED		RW	-	-	X
Bit 5	-		RESERVED		RW	-	-	X
Bit 4	-		RESERVED		RW	-	-	X
Bit 3	-		RESERVED		RW	-	-	X
Bit 2	-		RESERVED		RW	-	-	X
Bit 1	-		PLL BW #adjust	Selects PLL Bandwidth	RW	Low BW	High BW	1
Bit 0	-		PLL Enable	Bypasses PLL for board test	RW	PLL bypassed (fan out mode)	PLL enabled (ZDB mode)	1

SMBus Table: Output Enable Register

Byte 1		Pin #	Name	Control Function	Type	0	1	PWD
Bit 7	-		RESERVED		RW	-	-	X
Bit 6	-		RESERVED		RW	-	-	X
Bit 5	-		RESERVED		RW	-	-	X
Bit 4	-		RESERVED		RW	-	-	X
Bit 3	-		RESERVED		RW	-	-	X
Bit 2	-		RESERVED		RW	-	-	X
Bit 1	-		RESERVED		RW	-	-	X
Bit 0	-		RESERVED		RW	-	-	X

SMBus Table: Function Select Register

Byte 2		Pin #	Name	Control Function	Type	0	1	PWD
Bit 7	-		RESERVED		RW	-	-	X
Bit 6	-		RESERVED		RW	-	-	X
Bit 5	-		RESERVED		RW	-	-	X
Bit 4	-		RESERVED		RW	-	-	X
Bit 3	-		RESERVED		RW	-	-	X
Bit 2	-		RESERVED		RW	-	-	X
Bit 1	-		RESERVED		RW	-	-	X
Bit 0	-		RESERVED		RW	-	-	X

SMBus Table: Vendor & Revision ID Register

Byte 3		Pin #	Name	Control Function	Type	0	1	PWD
Bit 7	-		RID3	REVISION ID	R	-	-	0
Bit 6	-		RID2		R	-	-	0
Bit 5	-		RID1		R	-	-	0
Bit 4	-		RID0		R	-	-	1
Bit 3	-		VID3	VENDOR ID	R	-	-	0
Bit 2	-		VID2		R	-	-	0
Bit 1	-		VID1		R	-	-	0
Bit 0	-		VID0		R	-	-	1

SMBus Table: DEVICE ID

Byte 4	Pin #	Name	Control Function	Type	0	1	PWD
Bit 7	-	Device ID = 06 Hex		R	-	-	0
Bit 6	-			R	-	-	0
Bit 5	-			R	-	-	0
Bit 4	-			R	-	-	0
Bit 3	-			R	-	-	0
Bit 2	-			R	-	-	1
Bit 1	-			R	-	-	1
Bit 0	-			R	-	-	0

SMBus Table: Byte Count Register

Byte 5	Pin #	Name	Control Function	Type	0	1	PWD
Bit 7	-	BC7	Writing to this register will configure how many bytes will be read back, default is 06 = 6 bytes.	RW	-	-	0
Bit 6	-	BC6		RW	-	-	0
Bit 5	-	BC5		RW	-	-	0
Bit 4	-	BC4		RW	-	-	0
Bit 3	-	BC3		RW	-	-	0
Bit 2	-	BC2		RW	-	-	1
Bit 1	-	BC1		RW	-	-	1
Bit 0	-	BC0		RW	-	-	0

## 20-Pin SSOP Package Drawing and Dimensions

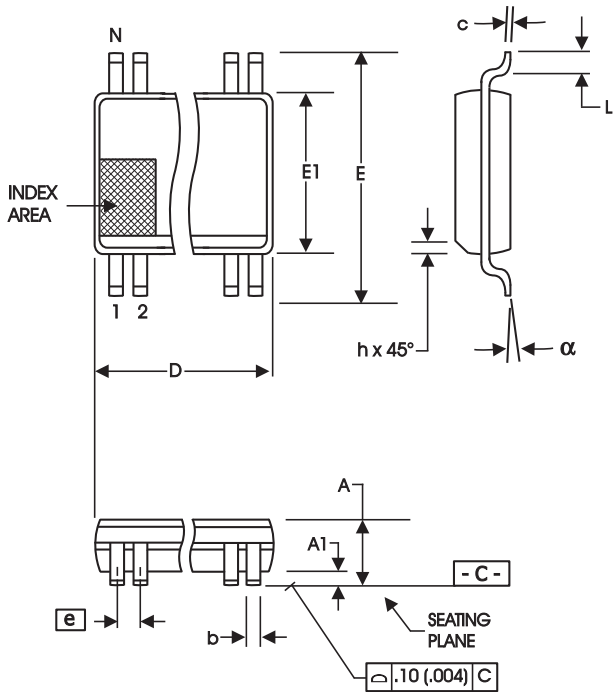

20-Lead, 150 mil SSOP (QSOP)

SYMBOL	In Millimeters		In Inches	
	COMMON DIMENSIONS		COMMON DIMENSIONS	
	MIN	MAX	MIN	MAX
A	1.35	1.75	.053	.069
A1	0.10	0.25	.004	.010
A2	--	1.50	--	.059
b	0.20	0.30	.008	.012
c	0.18	0.25	.007	.010
D	8.55	8.75	.337	.344
E	5.80	6.20	.228	.244
E1	3.80	4.00	.150	.157
e	0.635 BASIC		0.025 BASIC	
L	0.40	1.27	.016	.050
N	20		20	
a	0°	8°	0°	8°
ZD	1.47		.058	

## 20-Pin TSSOP Package Drawing and Dimensions

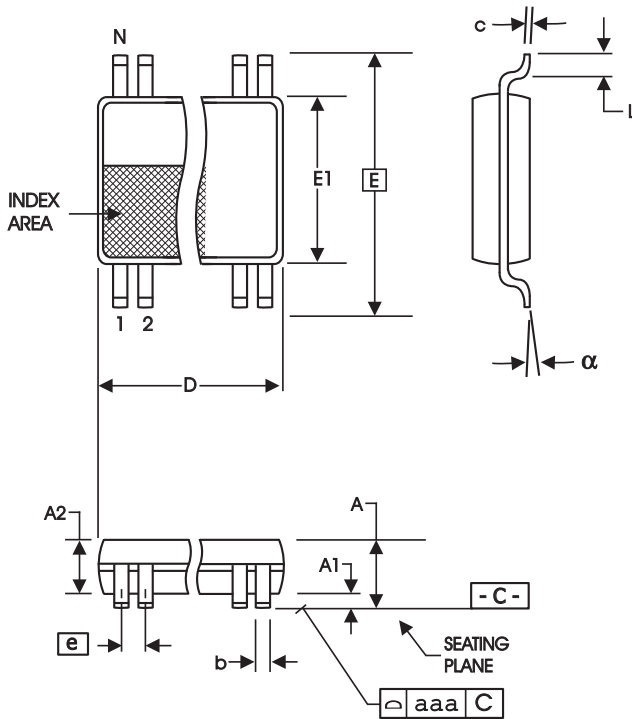

20-Lead, 4.40 mm. Body, 0.65 mm. Pitch TSSOP  
(173 mil) (25.6 mil)

SYMBOL	In Millimeters		In Inches	
	COMMON DIMENSIONS		COMMON DIMENSIONS	
	MIN	MAX	MIN	MAX
A	--	1.20	--	.047
A1	0.05	0.15	.002	.006
A2	0.80	1.05	.032	.041
b	0.19	0.30	.007	.012
c	0.09	0.20	.0035	.008
D	6.40	6.60	.252	.260
E	6.40 BASIC		0.252 BASIC	
E1	4.30	4.50	.169	.177
e	0.65 BASIC		0.0256 BASIC	
L	0.45	0.75	.018	.030
N	20		20	
a	0°	8°	0°	8°
aaa	--	0.10	--	.004

Reference Doc.: JEDEC Publication 95, MO-153

10-0035

## Ordering Information

Part / Order Number	Shipping Packaging	Package	Temperature
9DB102BFLF	Tubes	20-pin SSOP	0 to +70°C
9DB102BFLFT	Tape and Reel	20-pin SSOP	0 to +70°C
9DB102BFILF	Tubes	20-pin SSOP	-40 to +85°C
9DB102BFILFT	Tape and Reel	20-pin SSOP	-40 to +85°C
9DB102BGLF	Tubes	20-pin TSSOP	0 to +70°C
9DB102BGLFT	Tape and Reel	20-pin TSSOP	0 to +70°C
9DB102BGILF	Tubes	20-pin TSSOP	-40 to +85°C
9DB102BGILFT	Tape and Reel	20-pin TSSOP	-40 to +85°C

"LF" after the package code are the Pb-Free configuration and are RoHS compliant.  
"B" is the device revision designator (will not correlate to the datasheet revision).

## Revision History

Rev.	Originator	Issue Date	Description	Page #
F		8/6/2007	1. Added Phase Noise Parameters, Updated input to output delay values. 2. PLL BW moved to PLL parameters table. 3. Added terminations tables.	Various
G		12/14/2007	Updated General SMBus Interface Information.	8
H		10/29/2008	Corrected "HCSL" typos.	1, 6, 7
J		1/15/2010	1. Added I-temp electricals 2. Changed datasheet title 3. Updated Input Frequency parameter 4. Updated ordering information	Various
K	RW	4/1/2010	Updated ordering info for Rev B	
L	DC	9/28/2010	Updated package dimension tables	11, 12
M	RDW	1/27/2011	Updated Termination Figure 4.	7
N	RDW	4/20/2011	Changed pulldown indicator on CLKREQ# pins to correct pin description of those pins.	
P	AT	5/24/2012	Added OE# Latency spec to Common Input/Output Parameters table	3
Q	J. Chao	8/27/2013	Updated PLL Bandwidth specs per latest characterization data,	3

## IMPORTANT NOTICE AND DISCLAIMER

RENESAS ELECTRONICS CORPORATION AND ITS SUBSIDIARIES (“RENESAS”) PROVIDES TECHNICAL SPECIFICATIONS AND RELIABILITY DATA (INCLUDING DATASHEETS), DESIGN RESOURCES (INCLUDING REFERENCE DESIGNS), APPLICATION OR OTHER DESIGN ADVICE, WEB TOOLS, SAFETY INFORMATION, AND OTHER RESOURCES “AS IS” AND WITH ALL FAULTS, AND DISCLAIMS ALL WARRANTIES, EXPRESS OR IMPLIED, INCLUDING, WITHOUT LIMITATION, ANY IMPLIED WARRANTIES OF MERCHANTABILITY, FITNESS FOR A PARTICULAR PURPOSE, OR NON-INFRINGEMENT OF THIRD-PARTY INTELLECTUAL PROPERTY RIGHTS.

These resources are intended for developers who are designing with Renesas products. You are solely responsible for (1) selecting the appropriate products for your application, (2) designing, validating, and testing your application, and (3) ensuring your application meets applicable standards, and any other safety, security, or other requirements. These resources are subject to change without notice. Renesas grants you permission to use these resources only to develop an application that uses Renesas products. Other reproduction or use of these resources is strictly prohibited. No license is granted to any other Renesas intellectual property or to any third-party intellectual property. Renesas disclaims responsibility for, and you will fully indemnify Renesas and its representatives against, any claims, damages, costs, losses, or liabilities arising from your use of these resources. Renesas' products are provided only subject to Renesas' Terms and Conditions of Sale or other applicable terms agreed to in writing. No use of any Renesas resources expands or otherwise alters any applicable warranties or warranty disclaimers for these products.

(Disclaimer Rev.1.01)

### Corporate Headquarters

TOYOSU FORESIA, 3-2-24 Toyosu,  
Koto-ku, Tokyo 135-0061, Japan  
[www.renesas.com](http://www.renesas.com)

### Trademarks

Renesas and the Renesas logo are trademarks of Renesas Electronics Corporation. All trademarks and registered trademarks are the property of their respective owners.

### Contact Information

For further information on a product, technology, the most up-to-date version of a document, or your nearest sales office, please visit [www.renesas.com/contact-us/](http://www.renesas.com/contact-us/).