

Description

The 9DMV0141 is a member of IDT's SOC-Friendly 1.8V Very-Low-Power (VLP) PCIe Gen1-2-3 family. It has integrated output terminations providing $Z_0=100\Omega$ for direct connection to 100Ω transmission lines. The output has an OE# pin for optimal system control and power management. The part provides asynchronous or glitch-free switching modes.

Typical Application

2:1 PCIe Gen1-2-3 Clock Multiplexer

Output Features

- 1 -Low-Power (LP) HCSL DIF pair w/ $Z_0=100\Omega$

Key Specifications

- DIF *additive* cycle-to-cycle jitter <5ps
- DIF phase jitter is PCIe Gen1-2-3 compliant
- 125MHz additive phase jitter 420fs rms typical (12kHz to 20MHz)

Features

- LP-HCSL output w/integrated terminations; saves 4 resistors compared to standard HCSL output
- 1.8V operation; 12mW typical power consumption
- Selectable asynchronous or glitch-free switching; allows the mux to be selected at power up even if both inputs are not running, then transition to glitch-free switching mode
- Spread Spectrum Compatible; supports EMI reduction
- OE# pins; support DIF power management
- HCSL differential inputs; can be driven by common clock sources
- 1MHz to 200MHz operating frequency
- Configuration can be accomplished with strapping pins; SMBus interface not required for device control
- Space saving 16-pin 3x3mm VFQFPN; minimal board space

Block Diagram

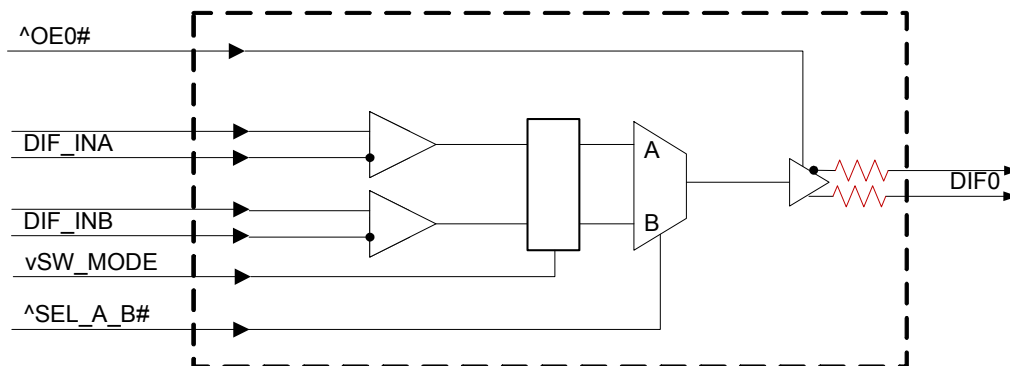

Pin Configuration

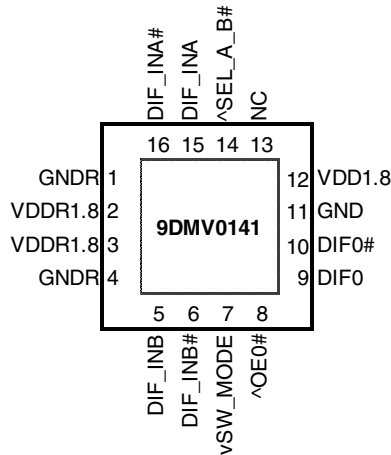

16-pin VFQFPN, 3x3 mm, 0.5mm pitch

^ prefix indicates internal 120KOhm pull up resistor
 v prefix indicates internal 120KOhm pull down resistor

Note: Paddle may be connected to ground for thermal purposes. It is not required electrically.

Power Management Table

OEx# Pin	DIF_IN	DIFx	
		True O/P	Comp. O/P
0	Running	Running	Running
1	Running	Low	Low

Power Connections

Pin Number		Description
VDD	GND	
2	1	Input A receiver analog
3	4	Input B receiver analog
12	11	DIF outputs

Pin Descriptions

Pin#	Pin Name	Type	Pin Description
1	GNDR	GND	Analog Ground pin for the differential input (receiver)
2	VDDR1.8	PWR	1.8V power for differential input clock (receiver). This VDD should be treated as an Analog power rail and filtered appropriately.
3	VDDR1.8	PWR	1.8V power for differential input clock (receiver). This VDD should be treated as an Analog power rail and filtered appropriately.
4	GNDR	GND	Analog Ground pin for the differential input (receiver)
5	DIF_INB	IN	HCSL Differential True input
6	DIF_INB#	IN	HCSL Differential Complement Input
7	vSW_MODE	IN	Switch Mode. This pin selects either asynchronous or glitch-free switching of the mux. Use asynchronous mode if 0 or 1 of the input clocks is running. Use glitch-free mode if both input clocks are running. This pin has an internal pull down resistor of ~120kohms. 0 = asynchronous mode 1 = glitch-free mode
8	^OE0#	IN	Active low input for enabling DIF pair 0. This pin has an internal pull-up resistor. 1 =disable outputs, 0 = enable outputs
9	DIF0	OUT	Differential true clock output
10	DIF0#	OUT	Differential Complementary clock output
11	GND	GND	Ground pin.
12	VDD1.8	PWR	Power supply, nominal 1.8V
13	NC	N/A	No Connection.
14	^SEL_A_B#	IN	Input to select differential input clock A or differential input clock B. This input has an internal pull-up resistor. 0 = Input B selected, 1 = Input A selected.
15	DIF_INA	IN	HCSL Differential True input
16	DIF_INA#	IN	HCSL Differential Complement Input

Test Loads

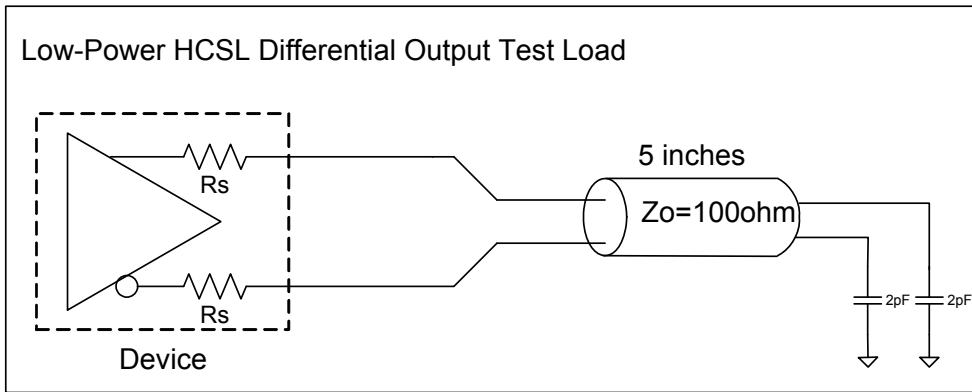

Driving LVDS

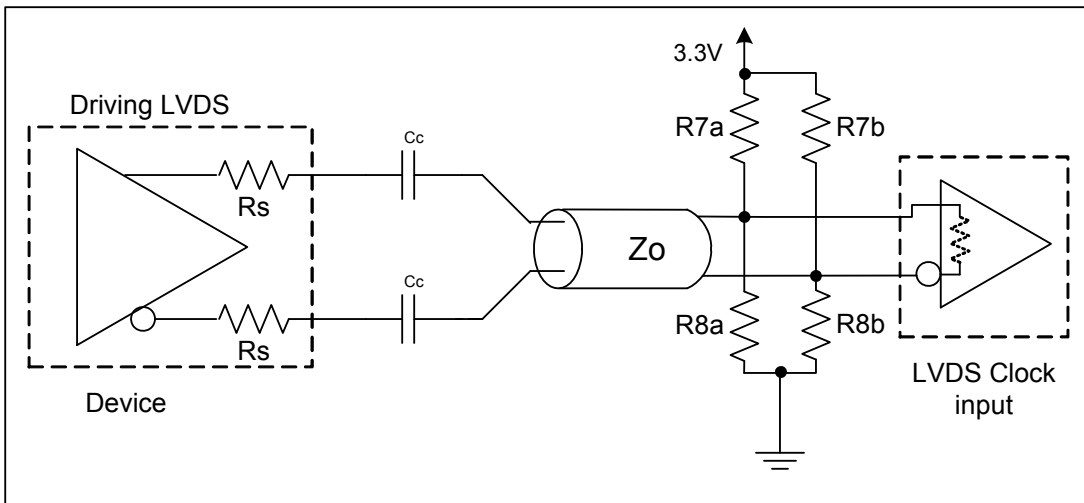

Driving LVDS inputs

Component	Value		Note
	Receiver has termination	Receiver does not have termination	
R7a, R7b	10K ohm	140 ohm	
R8a, R8b	5.6K ohm	75 ohm	
C_c	0.1 uF	0.1 uF	
V_{cm}	1.2 volts	1.2 volts	

Electrical Characteristics–Absolute Maximum Ratings

PARAMETER	SYMBOL	CONDITIONS	MIN	TYP	MAX	UNITS	NOTES
Supply Voltage	VDDxx	Applies to all VDD pins	-0.5		2.5	V	1,2
Input Voltage	V _{IN}		-0.5		V _{DD} +0.5V	V	1, 3
Input High Voltage, SMBus	V _{IHSMB}	SMBus clock and data pins			3.6V	V	1
Storage Temperature	T _s		-65		150	°C	1
Junction Temperature	T _j				125	°C	1
Input ESD protection	ESD prot	Human Body Model	2000			V	1

¹Guaranteed by design and characterization, not 100% tested in production.

²Operation under these conditions is neither implied nor guaranteed.

³Not to exceed 2.5V.

Electrical Characteristics–Input/Supply/Common Parameters–Normal Operating Conditions

T_A = T_{AMB}, Supply Voltages per normal operation conditions, See Test Loads for Loading Conditions

PARAMETER	SYMBOL	CONDITIONS	MIN	TYP	MAX	UNITS	NOTES
Supply Voltage	VDDxx	Applies to all VDD pins	1.7	1.8	1.9	V	
Ambient Operating Temperature	T _{AMB}	Industrial range	-40	25	85	°C	1
Input High Voltage	V _{IH}	Single-ended inputs, except SMBus	0.75 V _{DD}		V _{DD} + 0.3	V	
Input Low Voltage	V _{IL}	Single-ended inputs, except SMBus	-0.3		0.25 V _{DD}	V	
Input Current	I _{IN}	Single-ended inputs, V _{IN} = GND, V _{IN} = VDD	-5		5	uA	
	I _{INP}	Single-ended inputs V _{IN} = 0 V; Inputs with internal pull-up resistors V _{IN} = VDD; Inputs with internal pull-down resistors	-200		200	uA	
Input Frequency	F _{ibyp}		1		200	MHz	2
Pin Inductance	L _{pin}				7	nH	1
Capacitance	C _{IN}	Logic Inputs, except DIF_IN	1.5		5	pF	1
	C _{INDIF_IN}	DIF_IN differential clock inputs	1.5		2.7	pF	1,4
	C _{OUT}	Output pin capacitance			6	pF	1
Clk Stabilization	T _{STAB}	From V _{DD} Power-Up and after input clock stabilization or de-assertion of PD# to 1st clock			1	ms	1,2
Input SS Modulation Frequency PCIe	f _{MODINPCIe}	Allowable Frequency for PCIe Applications (Triangular Modulation)	30		33	kHz	
Input SS Modulation Frequency non-PCIe	f _{MODIN}	Allowable Frequency for non-PCIe Applications (Triangular Modulation)	0		66	kHz	
OE# Latency	t _{LATOE#}	DIF start after OE# assertion DIF stop after OE# deassertion	1		3	clocks	1,3
T _{fall}	t _F	Fall time of single-ended control inputs			5	ns	1,2
T _{rise}	t _R	Rise time of single-ended control inputs			5	ns	1,2

¹Guaranteed by design and characterization, not 100% tested in production.

²Control input must be monotonic from 20% to 80% of input swing.

³Time from deassertion until outputs are >200 mV

⁴DIF_IN input

Electrical Characteristics–Clock Input Parameters

TA = T_{AMB}, Supply Voltages per normal operation conditions, See Test Loads for Loading Conditions

PARAMETER	SYMBOL	CONDITIONS	MIN	TYP	MAX	UNITS	NOTES
Input High Voltage - DIF_IN	V _{IHDIF}	Differential inputs (single-ended measurement)	300	750	1150	mV	1
Input Low Voltage - DIF_IN	V _{ILDIF}	Differential inputs (single-ended measurement)	V _{SS} - 300	0	300	mV	1
Input Common Mode Voltage - DIF_IN	V _{COM}	Common Mode Input Voltage	200		725	mV	1
Input Amplitude - DIF_IN	V _{SWING}	Peak to Peak value (V _{IHDIF} - V _{ILDIF})	300		1450	mV	1
Input Slew Rate - DIF_IN	dv/dt	Measured differentially	0.35		8	V/ns	1,2
Input Leakage Current	I _{IN}	V _{IN} = V _{DD} , V _{IN} = GND	-5		5	uA	
Input Duty Cycle	d _{in}	Measurement from differential waveform	45	50	55	%	1
Input Jitter - Cycle to Cycle	J _{DIFn}	Differential Measurement	0		150	ps	1

¹ Guaranteed by design and characterization, not 100% tested in production.

² Slew rate measured through +/-75mV window centered around differential zero

Electrical Characteristics–DIF Low-Power HCSL Outputs

TA = T_{AMB}, Supply Voltages per normal operation conditions, See Test Loads for Loading Conditions

PARAMETER	SYMBOL	CONDITIONS	MIN	TYP	MAX	UNITS	NOTES
Slew rate	Trf	Scope averaging on	1.8	3.0	4.2	V/ns	1,2,3
Slew rate matching	ΔTrf	Slew rate matching, Scope averaging on		3	20	%	1,2,4
Voltage High	V _{HIGH}	Statistical measurement on single-ended signal using oscilloscope math function. (Scope averaging on)	660	783	850	mV	
Voltage Low	V _{LOW}		-150	26	150		
Max Voltage	V _{max}	Measurement on single ended signal using absolute value. (Scope averaging off)		790	1150	mV	
Min Voltage	V _{min}		-300	9			
Vswing	Vswing	Scope averaging off	300	1514		mV	1,2
Crossing Voltage (abs)	V _{cross_abs}	Scope averaging off	250	393	550	mV	1,5
Crossing Voltage (var)	Δ-V _{cross}	Scope averaging off		12	140	mV	1,6

¹ Guaranteed by design and characterization, not 100% tested in production.

² Measured from differential waveform

³ Slew rate is measured through the Vswing voltage range centered around differential 0V. This results in a +/-150mV window around differential 0V.

⁴ Matching applies to rising edge rate for Clock and falling edge rate for Clock#. It is measured using a +/-75mV window centered on the average cross point where Clock rising meets Clock# falling. The median cross point is used to calculate the voltage thresholds the oscilloscope is to use for the edge rate calculations.

⁵ V_{cross} is defined as voltage where Clock = Clock# measured on a component test board and only applies to the differential rising edge (i.e. Clock rising and Clock# falling).

⁶ The total variation of all V_{cross} measurements in any particular system. Note that this is a subset of V_{cross_min}/max (V_{cross} absolute) allowed. The intent is to limit V_{cross} induced modulation by setting Δ-V_{cross} to be smaller than V_{cross} absolute.

Electrical Characteristics–Current Consumption

TA = T_{AMB}, Supply Voltages per normal operation conditions, See Test Loads for Loading Conditions

PARAMETER	SYMBOL	CONDITIONS	MIN	TYP	MAX	UNITS	NOTES
Operating Supply Current	I _{DDOP}	VDD rails, All outputs active @100MHz		7.9	12	mA	
Disable Current	I _{DDIS}	VDD rails, All outputs disabled Low/Low		1.5	2.5	mA	2

¹ Guaranteed by design and characterization, not 100% tested in production.

² Input clock stopped after outputs have parked Low/Low.

Electrical Characteristics–Output Duty Cycle, Jitter, Skew and PLL Characteristics

TA = T_{AMB}, Supply Voltages per normal operation conditions, See Test Loads for Loading Conditions

PARAMETER	SYMBOL	CONDITIONS	MIN	TYP	MAX	UNITS	NOTES
Duty Cycle Distortion	t _{DCD}	Measured differentially, @100MHz	-1	-0.12	1	%	1,3
Skew, Input to Output	t _{pdBYP}	V _T = 50%	1853	2409	3132	ps	1
Jitter, Cycle to cycle	t _{jCyc-cyc}	Additive Jitter		0.1	5	ps	1,2

¹ Guaranteed by design and characterization, not 100% tested in production.

² Measured from differential waveform

³ Duty cycle distortion is the difference in duty cycle between the output and the input clock.

Electrical Characteristics–Phase Jitter Parameters

TA = T_{AMB}, Supply Voltages per normal operation conditions, See Test Loads for Loading Conditions

PARAMETER	SYMBOL	CONDITIONS	MIN	TYP	MAX	INDUSTRY LIMIT	UNITS	Notes
Additive Phase Jitter, Bypass Mode	t _{jphPCleG1}	PCIe Gen 1		1.3	5	N/A	ps (p-p)	1,2,3,5
	t _{jphPCleG2}	PCIe Gen 2 Lo Band 10kHz < f < 1.5MHz		0.1	0.3	N/A	ps (rms)	1,2,3,4,5
		PCIe Gen 2 High Band 1.5MHz < f < Nyquist (50MHz)		0.1	0.2	N/A	ps (rms)	1,2,3,4
	t _{jphPCleG3}	PCIe Gen 3 (PLL BW of 2-4 or 2-5MHz, CDR = 10MHz)		0.065	0.1	N/A	ps (rms)	1,2,3,4
	t _{jph125M0}	125MHz, 1.5MHz to 10MHz, -20dB/decade rollover < 1.5MHz, -40db/decade rolloff > 10MHz		284	350	N/A	fs (rms)	1,6
	t _{jph125M1}	125MHz, 12KHz to 20MHz, -20dB/decade rollover < 12kHz, -40db/decade rolloff > 20MHz		420	500	N/A	fs (rms)	1,6

¹ Guaranteed by design and characterization, not 100% tested in production.

² See <http://www.pcisig.com> for complete specs

³ Sample size of at least 100K cycles. This figures extrapolates to 108ps pk-pk @ 1M cycles for a BER of 1-12.

⁴ For RMS figures, additive jitter is calculated by solving the following equation: Additive jitter = SQRT[(total jitter)² - (input jitter)²]

⁵ Driven by 9FGV0831 or equivalent

⁶ Driven by Rohde & Schwartz SMA100

Marking Diagram



Notes:

1. "XXX" is the last 3 characters of the lot number.
2. "YYWW" is the last two digits of the year and week that the part was assembled.
3. Line 3: truncated part number
4. "L" denotes RoHS compliant package.
5. "I" denotes industrial temperature grade.

Thermal Characteristics

PARAMETER	SYMBOL	CONDITIONS	PKG	TYP VALUE	UNITS	NOTES
Thermal Resistance	θ_{JC}	Junction to Case	NLG16	66	°C/W	1
	θ_{Jb}	Junction to Base		5	°C/W	1
	θ_{JA0}	Junction to Air, still air		63	°C/W	1
	θ_{JA1}	Junction to Air, 1 m/s air flow		56	°C/W	1
	θ_{JA3}	Junction to Air, 3 m/s air flow		51	°C/W	1
	θ_{JA5}	Junction to Air, 5 m/s air flow		49	°C/W	1

¹ePad soldered to board

Package Outline and Dimensions (NLG16P2)



16-QFN Package Outline Drawing

3.0 x 3.0 x 1.0 mm, 0.5 mm Pitch 16-QFN, 1.70 x 1.70 mm Epad
 NL/NLG16P2, PSC-4169-02, Rev 02, Page 1

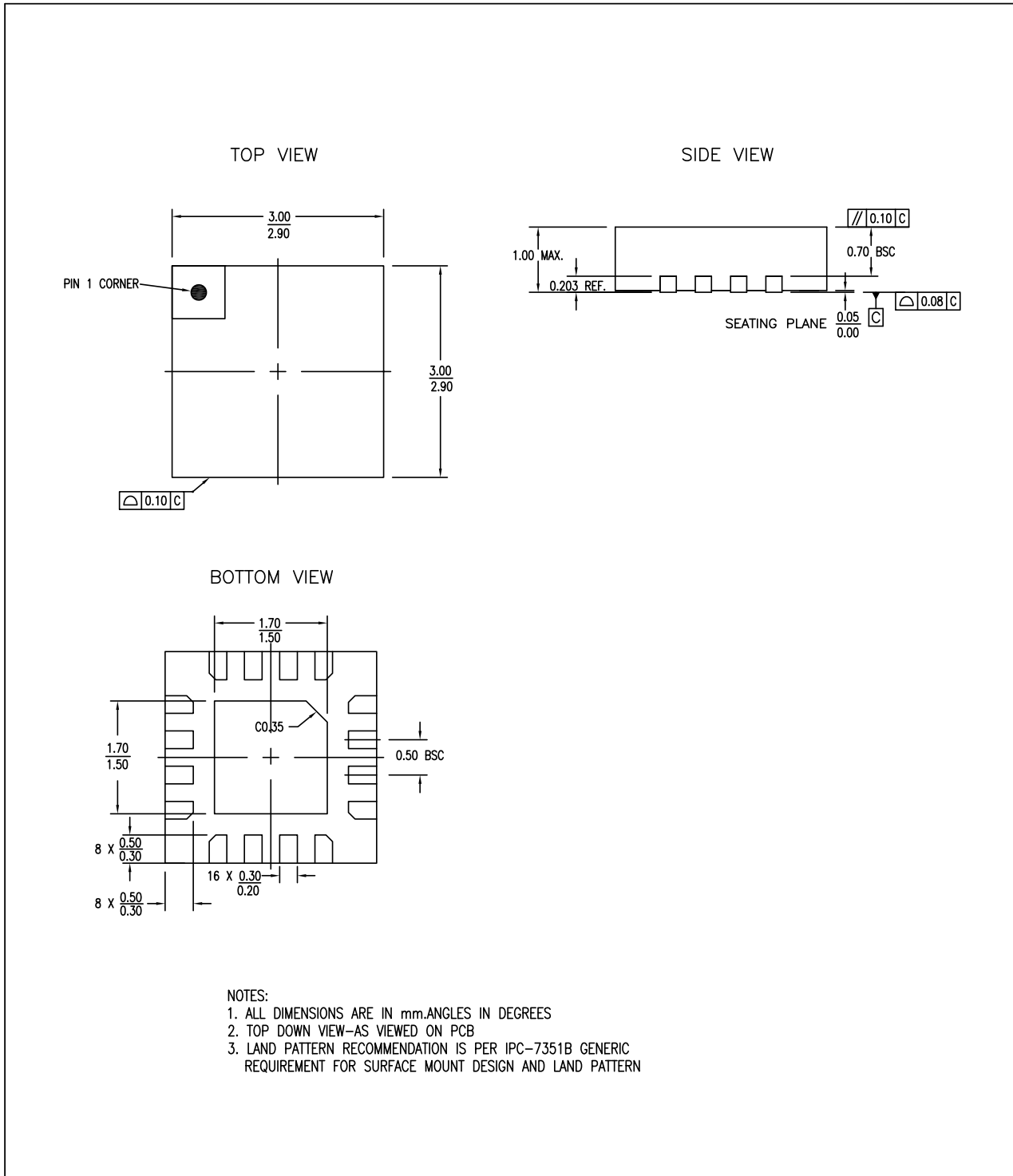

Package Outline and Dimensions (NLG16P2), cont.



16-QFN Package Outline Drawing

3.0 x 3.0 x 1.0 mm, 0.5 mm Pitch 16-QFN, 1.70 x 1.70 mm Epad
 NL/NLG16P2, PSC-4169-02, Rev 02, Page 2

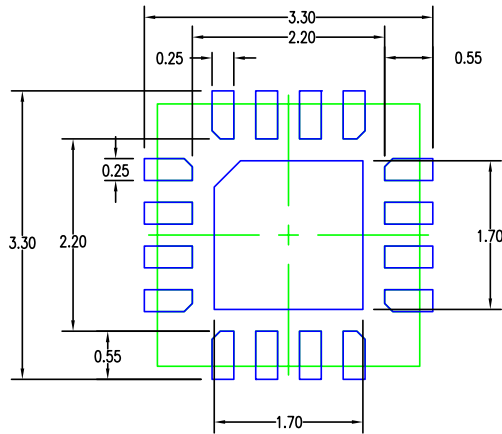

RECOMMENDED LAND PATTERN

Package Revision History		
Date Created	Rev No.	Description
Jul 28, 2017	Rev 02	New format
Feb 27, 2017	Rev 01	Change "L" Tolerance from 0.05 to 0.10

Ordering Information

Part / Order Number	Shipping Packaging	Package	Temperature
9DMV0141AKILF	Trays	16-pin VFQFPN	-40 to +85° C
9DMV0141AKILFT	Tape and Reel	16-pin VFQFPN	-40 to +85° C

“LF” to the suffix denotes Pb-Free configuration, RoHS compliant.

“A” is the device revision designator (will not correlate with the datasheet revision).

Revision History

Rev.	Initiator	Issue Date	Description	Page #
A	RDW	9/29/2014	1. Update front page text and electrical tables with char data. 2. Update pinout diagram with note about package paddle. 3. Move to final.	Various
B	RDW	1/26/2015	Updated package drawing to the latest NLG16 document.	8
C	RDW	5/11/2007	Updated package drawing to the latest NLG16 document.	8,9
D	RDW	8/15/2017	Updated package drawing to NLG16P2 document.	8,9

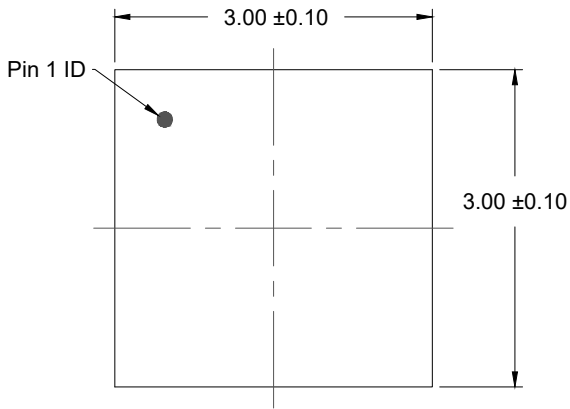

TOP VIEW

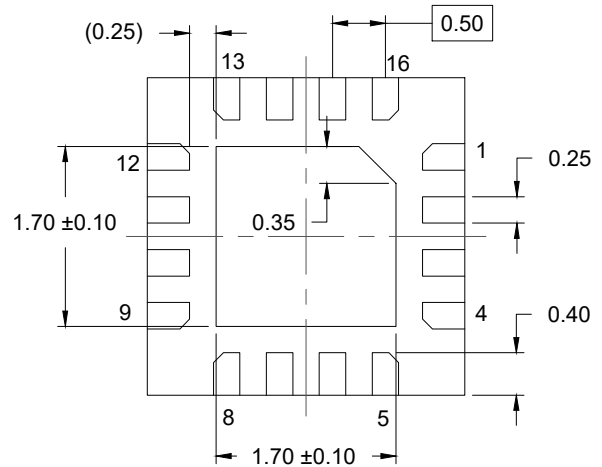

BOTTOM VIEW

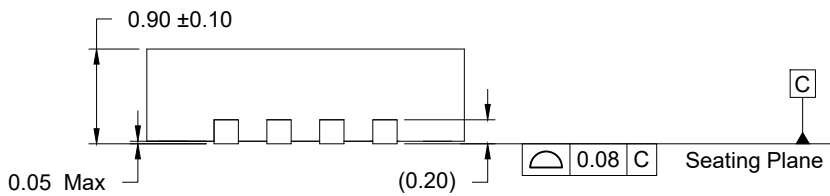

SIDE VIEW

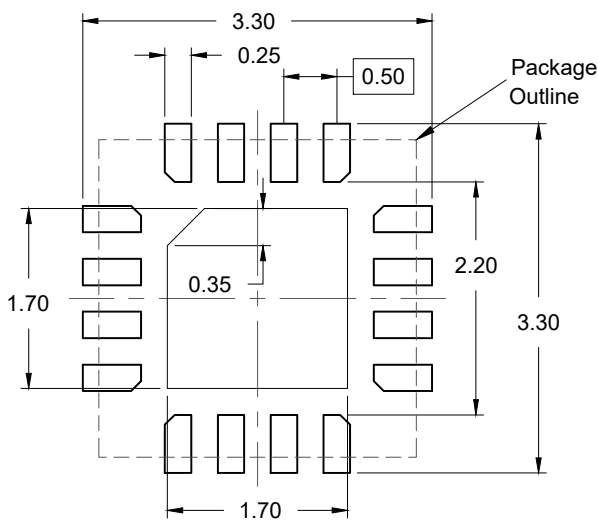

RECOMMENDED LAND PATTERN
(PCB Top View, NSMD Design)

NOTES:

1. JEDEC compatible.
2. All dimensions are in mm and angles are in degrees.
3. Use ± 0.05 mm for the non-toleranced dimensions.
4. Numbers in () are for references only.

IMPORTANT NOTICE AND DISCLAIMER

RENESAS ELECTRONICS CORPORATION AND ITS SUBSIDIARIES (“RENESAS”) PROVIDES TECHNICAL SPECIFICATIONS AND RELIABILITY DATA (INCLUDING DATASHEETS), DESIGN RESOURCES (INCLUDING REFERENCE DESIGNS), APPLICATION OR OTHER DESIGN ADVICE, WEB TOOLS, SAFETY INFORMATION, AND OTHER RESOURCES “AS IS” AND WITH ALL FAULTS, AND DISCLAIMS ALL WARRANTIES, EXPRESS OR IMPLIED, INCLUDING, WITHOUT LIMITATION, ANY IMPLIED WARRANTIES OF MERCHANTABILITY, FITNESS FOR A PARTICULAR PURPOSE, OR NON-INFRINGEMENT OF THIRD-PARTY INTELLECTUAL PROPERTY RIGHTS.

These resources are intended for developers who are designing with Renesas products. You are solely responsible for (1) selecting the appropriate products for your application, (2) designing, validating, and testing your application, and (3) ensuring your application meets applicable standards, and any other safety, security, or other requirements. These resources are subject to change without notice. Renesas grants you permission to use these resources only to develop an application that uses Renesas products. Other reproduction or use of these resources is strictly prohibited. No license is granted to any other Renesas intellectual property or to any third-party intellectual property. Renesas disclaims responsibility for, and you will fully indemnify Renesas and its representatives against, any claims, damages, costs, losses, or liabilities arising from your use of these resources. Renesas' products are provided only subject to Renesas' Terms and Conditions of Sale or other applicable terms agreed to in writing. No use of any Renesas resources expands or otherwise alters any applicable warranties or warranty disclaimers for these products.

(Disclaimer Rev.1.01)

Corporate Headquarters

TOYOSU FORESIA, 3-2-24 Toyosu,
Koto-ku, Tokyo 135-0061, Japan
www.renesas.com

Trademarks

Renesas and the Renesas logo are trademarks of Renesas Electronics Corporation. All trademarks and registered trademarks are the property of their respective owners.

Contact Information

For further information on a product, technology, the most up-to-date version of a document, or your nearest sales office, please visit www.renesas.com/contact-us/.