

Embedded 56-pin Industrial Temperature Range CK505 Compatible Clock

ICS9ERS3125

Recommended Application:

Industrial temperature CK505-compatible clock

Output Features:

- 2 - CPU differential push-pull pairs
- 4 - SRC differential push-pull pairs
- 1 - CPU/SRC selectable differential push-pull pair
- 1 - DOT96/SRC selectable differential push-pull pair
- 1 - 27M/SRC/SE selectable pair
- 1 - SRC/SATA selectable differential push-pull pair
- 5 - PCI, 33MHz
- 1 - PCI_F 33MHz free running
- 1 - USB, 48MHz
- 1 - REF, 14.31818MHz

Key Specifications:

- CPU outputs cycle-cycle jitter < 85ps
- SRC output cycle-cycle jitter < 125ps
- PCI outputs cycle-cycle jitter < 250ps
- +/- 100ppm frequency accuracy on all outputs

Pin Configuration

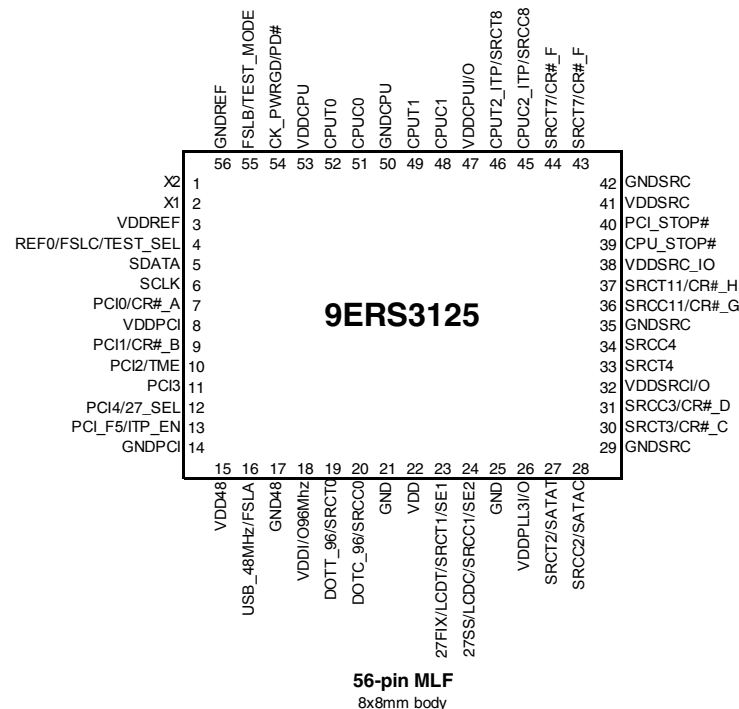

Features/Benefits:

- Fully integrated Vreg
- Differential outputs have integrated series resistors to give Zo = 50 Ohms
- Supports spread spectrum modulation, 0 to -0.5% down spread
- Supports CPU clks up to 400MHz
- Uses external 14.318MHz crystal, external crystal load caps are required for frequency tuning

Table 1: CPU Frequency Select Table

FS _L C ² B0b7	FS _L B ¹ B0b6	FS _L A ¹ B0b5	CPU MHz	SRC MHz	PCI MHz	REF MHz	USB MHz	DOT MHz
0	0	0	266.66	100.00	33.33	14.318	48.00	96.00
0	0	1	133.33					
0	1	0	200.00					
0	1	1	166.66					
1	0	0	333.33					
1	0	1	100.00					
1	1	0	400.00					
1	1	1	Reserved					

1. FS_LA and FS_LB are low-threshold inputs. Please see V_{IL,FS} and V_{IH,FS} specifications in the Input/Supply/Common Output Parameters Table for correct values. Also refer to the Test Clarification Table.
2. FS_LC is a three-level input. Please see the V_{IL,FS} and V_{IH,FS} specifications in the Input/Supply/Common Output Parameters Table for correct values.

27_SEL	pin19	pin20
0 (B1b7=1)	DOT96T	DOT96C
1 (B1b7=0)	SRCT0	SRCC0

27_SEL	pin23	pin24
0	LCDT_SS	LCDC_SS
1	27FIX	27SS

NOTE: Pin 23/24 defaults to a different spread domain than SRC without BIOS intervention.

CR # Control Table	PCIEX pair control	CR # SEL	
		0	1
CR #A	SRC0 or SRC2	SRC0	SRC2
CR #B	SRC1 or SRC4	SRC1	SRC4
CR #C	SRC0 or SRC2	SRC0	SRC2
CR #D	SRC1 or SRC4	SRC1	SRC4
CR #E	SRC6	-	-
CR #F	SRC8	-	-
CR #G	N/A	-	-
CR #H	N/A	-	-

Pin Description

PIN #	PIN NAME	TYPE	DESCRIPTION
1	X2	OUT	Crystal output, nominally 14.318MHz.
2	X1	IN	Crystal input, Nominally 14.318MHz.
3	VDDREF	PWR	Power pin for the REF outputs, 3.3V nominal.
4	REF0/FSLC/TEST_SEL	I/O	3.3V 14.318MHz reference clock/3.3V tolerant low threshold input for CPU frequency selection. Refer to input electrical characteristics for V_{il_FS} and V_{ih_FS} values/ TEST_SEL: 3-level latched input to enable test mode. Refer to Test Clarification Table.
5	SDATA	I/O	Data pin for SMBus circuitry, 5V tolerant.
6	SCLK	IN	Clock pin of SMBus circuitry, 5V tolerant.
7	PCI0/CR#_A	I/O	3.3V PCI clock output or Clock Request control A for either SRC0 or SRC2 pair The power-up default is PCI0 output, but this pin may also be used as a Clock Request control of SRC pair 0 or SRC pair 2 via SMBus. Before configuring this pin as a Clock Request Pin, the PCI output must first be disabled in byte 2, bit 0 of SMBus address space . After the PCI output is disabled (high-Z), the pin can then be set to serve as a Clock Request pin for either SRC pair 2 or pair 0 using the CR#_A_EN bit located in byte 5 of SMBUS address space. Byte 5, bit 7 0 = PCI0 enabled (default) 1= CR#_A enabled. Byte 5, bit 6 controls whether CR#_A controls SRC0 or SRC2 pair Byte 5, bit 6 0 = CR#_A controls SRC0 pair (default), 1= CR#_A controls SRC2 pair
8	VDDPCI	PWR	Power supply pin for the PCI outputs, 3.3V nominal
9	PCI1/CR#_B	I/O	3.3V PCI clock output/Clock Request control B for either SRC1 or SRC4 pair The power-up default is PCI1 output, but this pin may also be used as a Clock Request control of SRC pair 1 or SRC pair 4 via SMBus. Before configuring this pin as a Clock Request Pin, the PCI output must first be disabled in byte 2, bit 1 of SMBus address space . After the PCI output is disabled (high-Z), the pin can then be set to serve as a Clock Request pin for either SRC pair 1 or pair 4 using the CR#_B_EN bit located in byte 5 of SMBUS address space. Byte 5, bit 5 0 = PCI1 enabled (default) 1= CR#_B enabled. Byte 5, bit 4 controls whether CR#_B controls SRC1 or SRC4 pair Byte 5, bit 4 0 = CR#_B controls SRC1 pair (default) 1= CR#_B controls SRC4 pair
10	PCI2/TME	I/O	3.3V PCI clock output / Trusted Mode Enable (TME) Latched Input. This pin is sampled on power-up as follows 0 = Overclocking of CPU and SRC Allowed 1 = Overclocking of CPU and SRC NOT allowed After being sampled on power-up, this pin becomes a 3.3V PCI Output
11	PCI3	OUT	3.3V PCI clock output.
12	PCI4/27_SEL	I/O	3.3V PCI clock output / 27MHz mode select for pin23, 24 strap. On powerup, the logic value on this pin determines the power-up default of DOT_96/SRC0 and 27MHz/LCD/SRC1 output and the function table for the pin23 and pin24.
13	PCI_F5/ITP_EN	I/O	Free running PCI clock output and ITP/SRC8 enable strap. This output is not affected by the state of the PCI_STOP# pin. On powerup, the state of this pin determines whether pins 45 and 46 are an ITP or SRC pair. 0 =SRC8/SRC8# 1 = ITP/ITP#
14	GNDPCI	PWR	Ground for PCI clocks.
15	VDD48	PWR	Power supply for USB clock, nominal 3.3V.
16	USB_48MHz/FSLA	I/O	Fixed 48MHz USB clock output. 3.3V./ 3.3V tolerant input for CPU frequency selection. Refer to input electrical characteristics for V_{il_FS} and V_{ih_FS} values.
17	GND48	PWR	Ground pin for the 48MHz outputs.
18	VDD96_IO	PWR	Power supply for DOT96 output. 1.05 to 3.3V +/-5%.
19	DOTT_96/SRCT0	OUT	True clock of SRC or DOT96. The power-up default function is SRC0. After powerup, this pin function may be changed to DOT96 via SMBus Byte 1, bit 7 as follows: 0= SRC0 1=DOT96
20	DOTC_96/SRCC0	OUT	Complement clock of SRC or DOT96. The power-up default function is SRC0#. After powerup, this pin function may be changed to DOT96# via SMBus Byte 1, bit 7 as follows 0= SRC0# 1=DOT96#

Pin Description (continued)

21	GND	PWR	Ground pin for the DOT96 clocks.
22	VDD	PWR	Power supply for SRC / SE1 and SE2 clocks, 3.3V nominal.
23	27FIX/LCDD/SRCT_LR1/SE1	OUT	Single-ended 3.3V 27MHz fix clock output / True clock of differential SRC1 or LCD clock pair / Single ended 3.3V peripheral clock output. The default output selection is determined by the SEL_27 default latch value. See below: 27_SEL=0: LCD100 with -0.5% down spread is selected as default. LCD100 spread percentage can be adjusted OR output can be changed to SRC or 3.3V single-ended peripheral clock output via SMBUs B1b[4:1]. 27_SEL=1: Single-ended 27FIX output is selected.
24	27SS/LCDD/SRCC_LR1/SE2	OUT	Single-ended 3.3V 27MHz fix clock output / Complementary clock of differential SRC1 or LCD clock pair / Single ended 3.3V peripheral clock output. The default output selection is determined by the SEL_27 default latch value. See below: 27_SEL=0: LCD100 with -0.5% down spread is selected as default. LCD100 spread percentage can be adjusted OR output can be changed to SRC or 3.3V single-ended peripheral clock output via SMBUs B1b[4:1]. 27_SEL=1: Single-ended 27SS output is selected with -0.5% down spread as default. Spread percentage can be adjusted via SMBus B1b[4:1].
25	GND	PWR	Ground pin for SRC / SE1 and SE2 clocks, PLL3.
26	VDDPLL3_IO	PWR	Power supply for PLL3 output. 1.05 to 3.3V +/-5%.
27	SRCT2/SATAT	OUT	True clock of differential SRC/SATA clock pair.
28	SRCC2/SATAC	OUT	Complement clock of differential SRC/SATA clock pair.
29	GNDSRC	PWR	Ground pin for SRC clocks.
30	SRCT3/CR#_C	I/O	True clock of differential SRC clock pair/ Clock Request control C for either SRC0 or SRC2 pair The power-up default is SRCCLK3 output, but this pin may also be used as a Clock Request control of SRC pair 0 or SRC pair 2 via SMBus. Before configuring this pin as a Clock Request Pin, the SRC3 output must first be disabled in byte 4, bit 7 of SMBus address space. After the SRC3 output is disabled, the pin can then be set to serve as a Clock Request pin for either SRC pair 2 or pair 0 using the CR#_C_EN bit located in byte 5 of SMBUs address space. Byte 5, bit 3 0 = SRC3 enabled (default) 1 = CR#_C enabled. Byte 5, bit 2 controls whether CR#_C controls SRC0 or SRC2 pair Byte 5, bit 2 0 = CR#_C controls SRC0 pair (default), 1 = CR#_C controls SRC2 pair
31	SRCC3/CR#_D	I/O	Complementary clock of differential SRC clock pair/ Clock Request control D for either SRC1 or SRC4 pair The power-up default is SRCCLK3 output, but this pin may also be used as a Clock Request control of SRC pair 1 or SRC pair 4 via SMBus. Before configuring this pin as a Clock Request Pin, the SRC3 output must first be disabled in byte 4, bit 7 of SMBus address space. After the SRC3 output is disabled, the pin can then be set to serve as a Clock Request pin for either SRC pair 1 or pair 4 using the CR#_D_EN bit located in byte 5 of SMBUs address space. Byte 5, bit 1 0 = SRC3 enabled (default) 1 = CR#_D enabled. Byte 5, bit 0 controls whether CR#_D controls SRC1 or SRC4 pair Byte 5, bit 0 0 = CR#_D controls SRC1 pair (default), 1 = CR#_D controls SRC4 pair
32	VDDSRC_IO	PWR	Power supply for SRC clocks. 1.05 to 3.3V +/-5%.
33	SRCT4	I/O	True clock of differential SRC clock pair 4
34	SRCC4	I/O	Complement clock of differential SRC clock pair 4
35	GNDSRC	PWR	Ground for SRC clocks
36	SRCC11/CR#_G	I/O	SRCT11 complement /Clock Request control for SRC10 pair The power-up default is SRC11#, but this pin may also be used as a Clock Request control of SRC10 via SMBus. Before configuring this pin as a Clock Request Pin, the SRC11 output pair must first be disabled in byte 3, bit 7 of SMBus configuration space After the SRC11 output is disabled (high-Z), the pin can then be set to serve as a Clock Request for SRC10 pair using byte 6, bit 5 of SMBus configuration space Byte 6, bit 5 0 = SRC11# enabled (default) 1 = CR#_G controls SRC10 NOTE: SRC10 NOT AVAILABLE ON 9LRS3125

Pin Description (continued)

37	SRCT11/CR#_H	I/O	<p>SRC11 true or Clock Request control H for SRC11 pair</p> <p>The power-up default is SRC11, but this pin may also be used as a Clock Request control of SRC3 via SMBus. Before configuring this pin as a Clock Request Pin, the SRC11 output pair must first be disabled in byte 3, bit 7 of SMBus configuration space. After the SRC11 output is disabled (high-Z), the pin can then be set to serve as a Clock Request for SRC3 pair using byte 6, bit 4 of SMBus configuration space</p> <p>Byte 6, bit 4</p> <p>0 = SRC11 enabled (default)</p> <p>1 = CR#_H controls SRC3.</p> <p>NOTE: SRC10 NOT AVAILABLE ON 9LRS3125</p>
38	VDDSRC_IO	PWR	Power supply for SRC outputs. 1.05 to 3.3V +/-5%.
39	CPU_STOP#	IN	<p>Stops all CPU Clocks, except those set to be free running clocks.</p> <p>In AMT mode 3 bits are shifted in from the ICH to set the FSC, FSB, FSA values</p>
40	PCI_STOP#	IN	<p>Stops all PCI/SRC Clocks, except those set to be free running clocks.</p> <p>In AMT mode, this pin is a clock input which times the FSC, FSB, FSA bits shifted in on CPU_STOP#.</p>
41	VDDSRC	PWR	3.3V Power supply for SRC PLL and Logic
42	GNDSRC	PWR	Ground for SRC clocks
43	SRCC7CR#_E	I/O	<p>SRC7 complement or Clock Request control E for SRC6 pair</p> <p>The power-up default is SRC7#, but this pin may also be used as a Clock Request control of SRC6 via SMBus. Before configuring this pin as a Clock Request Pin, the SRC7 output pair must first be disabled in byte 3, bit 3 of SMBus configuration space. After the SRC output is disabled (high-Z), the pin can then be set to serve as a Clock Request for SRC6 pair using byte 6, bit 7 of SMBus configuration space</p> <p>Byte 6, bit 7</p> <p>0 = SRC7# enabled (default)</p> <p>1 = CR#_E controls SRC6.</p>
44	SRCT7/CR#_F	I/O	<p>SRC7 true or Clock Request control 8 for SRC8 pair</p> <p>The power-up default is SRC7, but this pin may also be used as a Clock Request control of SRC8 via SMBus. Before configuring this pin as a Clock Request Pin, the SRC7 output pair must first be disabled in byte 3, bit 3 of SMBus configuration space. After the SRC output is disabled (high-Z), the pin can then be set to serve as a Clock Request for SRC8 pair using byte 6, bit 6 of SMBus configuration space</p> <p>Byte 6, bit 6</p> <p>0 = SRC7# enabled (default)</p> <p>1 = CR#_F controls SRC8.</p>
45	CPUC2_ITP/SRCC8	OUT	<p>Complement clock of low power differential CPU2/Complement clock of differential SRC pair.</p> <p>The function of this pin is determined by the latched input value on pin 14, PCIF5/ITP_EN on powerup. The function is as follows:</p> <p>Pin 14 latched input Value</p> <p>0 = SRC8#</p> <p>1 = ITP#</p>
46	CPUT2_ITP/SRCT8	OUT	<p>True clock of low power differential CPU2/True clock of differential SRC pair. The function of this pin is determined by the latched input value on pin 14, PCIF5/ITP_EN on powerup. The function is as follows:</p> <p>Pin 14 latched input Value</p> <p>0 = SRC8</p> <p>1 = ITP</p>
47	VDDCPU/I/O	PWR	Power supply for CPU outputs. 1.05 to 3.3V +/-5%.
48	CPUC1_F	OUT	Complement clock of low power differential CPU clock pair. This clock will be free-running during iAMT.
49	CPUT1_F	OUT	True clock of low power differential CPU clock pair. This clock will be free-running during iAMT.
50	GNDCPU	PWR	Ground Pin for CPU Outputs
51	CPUC0	OUT	Complement clock of low power differential CPU clock pair.
52	CPUT0	OUT	True clock of low power differential CPU clock pair.
53	VDDCPU	PWR	3.3V Power Supply for CPU.
54	CK_PWRGD/PD#	IN	Notifies CK505 to sample latched inputs, or iAMT entry/exit, or PWRDWN# mode
55	FSLB/TEST_MODE	IN	3.3V tolerant input for CPU frequency selection. Refer to input electrical characteristics for V_{iL_FS} and V_{iH_FS} values. TEST_MODE is a real time input to select between Hi-Z and REF/N divider mode while in test mode. Refer to Test Clarification Table.
56	GNDREF	PWR	Ground pin for crystal oscillator circuit

General Description

ICS9ERS3125 is electrically compliant to the Intel CK505 Yellow Cover specification. This clock synthesizer provides a single chip solution for Intel chipsets. ICS9ERS3125 is driven with a 14.318MHz crystal.

Block Diagram

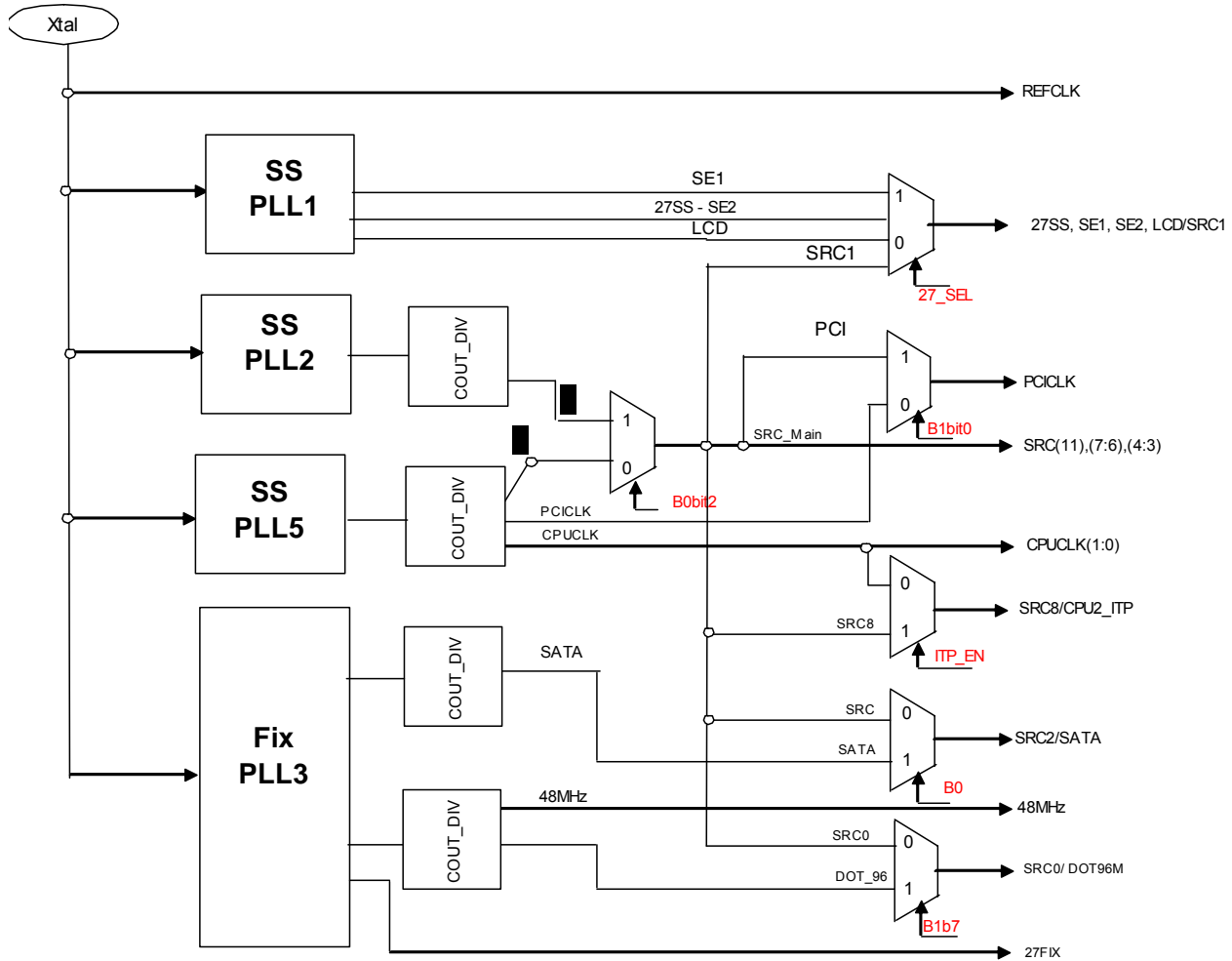

Power Groups

Pin Number		Description	
VDD	GND		
47	50	CPUCLK	Low power outputs
53	50	Master Clock, Analog	
26, 32, 38	29, 35, 42	SRCCLK	Low power outputs
41	42		PLL2
26	25	PLL1/SE	Low power outputs
22	25		PLL1
18	21	DOT 96Mhz	Low power outputs
15	17	USB 48 output and PLL	
3	56	Xtal, REF	
8	14	PCICLK	

Absolute Maximum Ratings

PARAMETER	SYMBOL	CONDITIONS	MIN	MAX	UNITS	Notes
Maximum Supply Voltage	VDDxxx	Supply Voltage		4.6	V	1,7
Maximum Supply Voltage	VDDxxx_IO	Low-Voltage Differential I/O Supply		3.8	V	1,7
Maximum Input Voltage	V _{IH}	3.3V LVCMOS Inputs		4.6	V	1,7,8
Minimum Input Voltage	V _{IL}	Any Input	GND - 0.5		V	1,7
Storage Temperature	T _s	-	-65	150	°C	1,7
Case Temperature	T _{case}			115	°C	1
Input ESD protection	ESD prot	Human Body Model	2000		V	1,7

Electrical Characteristics - Input/Supply/Common Output Parameters

PARAMETER	SYMBOL	CONDITIONS	MIN	TYPICAL	MAX	UNITS	Notes
Ambient Operating Temp	T _{ambient}	-	-40		85	°C	1
Supply Voltage	VDDxxx	Supply Voltage	3.135		3.465	V	1
Supply Voltage	VDDxxx_IO	Low-Voltage Differential I/O Supply	1		3.465	V	1
Input High Voltage	V _{IHSE}	Single-ended inputs	2		V _{DD} + 0.3	V	1
Input Low Voltage	V _{ILSE}	Single-ended inputs	V _{SS} - 0.3		0.8	V	1
Input Leakage Current	I _{IN}	V _{IN} = V _{DD} , V _{IN} = GND	-5		5	µA	1
Input Leakage Current	I _{INRES}	Inputs with pull or pull down resistors V _{IN} = V _{DD} , V _{IN} = GND	-200		200	µA	1
Output High Voltage	V _{OHSE}	Single-ended outputs, I _{OH} = -1mA	2.4			V	1
Output Low Voltage	V _{OLSE}	Single-ended outputs, I _{OL} = 1 mA			0.4	V	1
Output High Voltage	V _{OHDF}	Differential Outputs	0.7		0.9	V	1
Output Low Voltage	V _{OLDIF}	Differential Outputs			0.4	V	1
Low Threshold Input-High Voltage (Test Mode)	V _{IH_FS_TEST}	3.3 V +/-5%	2		V _{DD} + 0.3	V	1
Low Threshold Input-High Voltage	V _{IH_FS}	3.3 V +/-5%	0.7		1.5	V	1
Low Threshold Input-Low Voltage	V _{IL_FS}	3.3 V +/-5%	V _{SS} - 0.3		0.35	V	1
Operating Supply Current	I _{DD_DEFAULT}	3.3V supply, PLL1,2 off		95	125	mA	1
	I _{DD_PLL3DIF}	3.3V supply, PLL1,2 Differential Out		106	125	mA	1
	I _{DD_PLL3SE}	3.3V supply, PLL1,2 Single-ended Out		101	125	mA	1
	I _{DD_IO}	0.8V supply, Differential IO current, all outputs enabled	25	32	50	mA	1
Power Down Current	I _{DD_PD3.3}	3.3V supply, Power Down Mode		26	30	mA	1
	I _{DD_PDIO}	0.8V IO supply, Power Down Mode		0.23	0.5	mA	1
iAMT Mode Current	I _{DD_iAMT3.3}	3.3V supply, iAMT Mode		47	60	mA	1
	I _{DD_iAMT0.8}	0.8V IO supply, iAMT Mode		5	10	mA	1
Input Frequency	F _i	V _{DD} = 3.3 V			14.318	MHz	2
Pin Inductance	L _{pin}				7	nH	1
Input Capacitance	C _{IN}	Logic Inputs	1.5		5	pF	1
	C _{OUT}	Output pin capacitance			6	pF	1
	C _{INX}	X1 & X2 pins			5	pF	1
Spread Spectrum Modulation Frequency	f _{SSMOD}	Triangular Modulation	30		33	kHz	1

Electrical Characteristics - SMBus Interface

PARAMETER	SYMBOL	CONDITIONS	MIN	MAX	UNITS	Notes
SMBus Voltage	V_{DD}		2.7	5.5	V	1
Low-level Output Voltage	V_{OLSMB}	@ I_{PULLUP}		0.4	V	1
Current sinking at $V_{OLSMB} = 0.4$ V	I_{PULLUP}	SMB Data Pin	4		mA	1
SCLK/SDATA Clock/Data Rise Time	T_{R12C}	(Max VIL - 0.15) to (Min VIH + 0.15)		1000	ns	1
SCLK/SDATA Clock/Data Fall Time	T_{F12C}	(Min VIH + 0.15) to (Max VIL - 0.15)		300	ns	1
Maximum SMBus Operating Frequency	F_{SMBUS}	Block Mode		100	kHz	1

AC Electrical Characteristics - Input/Common Parameters

PARAMETER	SYMBOL	CONDITIONS	MIN	MAX	UNITS	Notes
Clk Stabilization	T_{STAB}	From VDD Power-Up or de-assertion of PD# to 1st clock		1.8	ms	1
Tdrive_SRC	T_{DRSRC}	SRC output enable after PCI_STOP# de-assertion		15	ns	1
Tdrive_PD#	T_{DRPD}	Differential output enable after PD# de-assertion		300	us	1
Tdrive_CPU	T_{DRSRC}	CPU output enable after CPU_STOP# de-assertion		10	ns	1
Tfall_PD#	T_{FALL}	Fall/rise time of PD#, PCI_STOP# and CPU_STOP# inputs		5	ns	1
Trise_PD#	T_{RISE}			5	ns	1

AC Electrical Characteristics - Low Power Differential Outputs

PARAMETER	SYMBOL	CONDITIONS	MIN	MAX	UNITS	NOTES
Rising Edge Slew Rate	t_{SLR}	Differential Measurement	2.5	8	V/ns	1,2
Falling Edge Slew Rate	t_{FLR}	Differential Measurement	2.5	8	V/ns	1,2
Slew Rate Variation	t_{SLVAR}	Single-ended Measurement		20	%	1
Maximum Output Voltage	V_{HIGH}	Includes overshoot		1150	mV	1
Minimum Output Voltage	V_{LOW}	Includes undershoot	-300		mV	1
Differential Voltage Swing	V_{SWING}	Differential Measurement	300		mV	1
Crossing Point Voltage	V_{XABS}	Single-ended Measurement	300	550	mV	1,3,4
Crossing Point Variation	$V_{XABSVAR}$	Single-ended Measurement		140	mV	1,3,5
Duty Cycle	D_{CYC}	Differential Measurement	45	55	%	1
CPU Jitter - Cycle to Cycle	$CPUJ_{C2C}$	Differential Measurement		85	ps	1
SRC Jitter - Cycle to Cycle	$SRCJ_{C2C}$	Differential Measurement		125	ps	1
SATA Jitter - Cycle to Cycle	$SATAJ_{C2C}$	Differential Measurement		125	ps	1
DOT Jitter - Cycle to Cycle	$DOTJ_{C2C}$	Differential Measurement		250	ps	1
CPU[1:0] Skew	CPU_{SKEW10}	Differential Measurement		100	ps	1
CPU[2_ITP:0] Skew	CPU_{SKEW20}	Differential Measurement		150	ps	1
SRC[11,7,4,2,0] Skew	SRC_{SKEW}	Differential Measurement	0 nominal		ps	1
SRC[11:0] Skew	SRC_{SKEW}	Differential Measurement		3	ns	1

*TA = -40 - 85°C; Supply Voltage VDD = 3.3 V +/-5%, Rs = 0Ω, CL = 2pF

Electrical Characteristics - PCICLK/PCICLK_F

PARAMETER	SYMBOL	CONDITIONS	MIN	MAX	UNITS	NOTES
Long Accuracy	ppm	see Tperiod min-max values	-100	100	ppm	1,6
Clock period	T _{period}	33.33MHz output nominal	29.99718	30.50300	ns	6
		33.33MHz output spread		30.15320	ns	6
Absolute min/max period	T _{abs}	33.33MHz output nominal/spread	29.49718	30.65320	ns	6
Output High Voltage	V _{OH}	I _{OH} = -1 mA	2.4		V	1
Output Low Voltage	V _{OL}	I _{OL} = 1 mA		0.4	V	1
Output High Current	I _{OH}	V _{OH} @ MIN = 1.0 V	-33		mA	1
		V _{OH} @ MAX = 3.135 V		-33	mA	1
Output Low Current	I _{OL}	V _{OL} @ MIN = 1.95 V	30		mA	1
		V _{OL} @ MAX = 0.4 V		38	mA	1
Rising Edge Slew Rate	t _{SLR}	Measured from 0.8 to 2.0 V	1	4	V/ns	1
Falling Edge Slew Rate	t _{FLR}	Measured from 2.0 to 0.8 V	1	4	V/ns	1
Duty Cycle	d _{tt}	V _T = 1.5 V	45	55	%	1
Skew	t _{skew}	V _T = 1.5 V		250	ps	1
Intentional PCI-PCI delay	t _{delay}	V _T = 1.5 V	200 nominal		ps	1,9
Jitter, Cycle to cycle	t _{jcy-cyc}	V _T = 1.5 V		500	ps	1

*TA = -40 - 85°C; Supply Voltage VDD = 3.3 V +/-5%, Rs = 39Ω, CL = 5pF

Electrical Characteristics - USB48MHz

PARAMETER	SYMBOL	CONDITIONS	MIN	MAX	UNITS	NOTES
Long Accuracy	ppm	see Tperiod min-max values	-100	100	ppm	1,6
Clock period	T _{period}	48.00MHz output nominal	20.83125	20.83542	ns	6
Absolute min/max period	T _{abs}	48.00MHz output nominal	20.13125	21.53542	ns	6
Output High Voltage	V _{OH}	I _{OH} = -1 mA	2.4		V	1
Output Low Voltage	V _{OL}	I _{OL} = 1 mA		0.4	V	1
Output High Current	I _{OH}	V _{OH} @ MIN = 1.0 V	-29		mA	1
		V _{OH} @ MAX = 3.135 V		-23	mA	1
Output Low Current	I _{OL}	V _{OL} @ MIN = 1.95 V	29		mA	1
		V _{OL} @ MAX = 0.4 V		27	mA	1
Rising Edge Slew Rate	t _{SLR}	Measured from 0.8 to 2.0 V	1	2	V/ns	1
Falling Edge Slew Rate	t _{FLR}	Measured from 2.0 to 0.8 V	1	2	V/ns	1
Duty Cycle	d _{tt}	V _T = 1.5 V	45	55	%	1
Jitter, Cycle to cycle	t _{jcy-cyc}	V _T = 1.5 V		350	ps	1

*TA = -40 - 85°C; Supply Voltage VDD = 3.3 V +/-5%, Rs = 39Ω, CL = 5pF

Electrical Characteristics - REF-14.318MHz

PARAMETER	SYMBOL	CONDITIONS	MIN	MAX	UNITS	Notes
Long Accuracy	ppm	see Tperiod min-max values	-100	100	ppm	1,6
Clock period	T _{period}	14.318MHz output nominal	69.8343	69.8483	ns	6
Absolute min/max period	T _{abs}	14.318MHz output nominal	68.8343	70.84825	ns	6
Output High Voltage	V _{OH}	I _{OH} = -1 mA	2.4		V	1
Output Low Voltage	V _{OL}	I _{OL} = 1 mA		0.4	V	1
Output High Current	I _{OH}	V _{OH} @ MIN = 1.0 V, V _{OH} @ MAX = 3.135 V	-33	-33	mA	1
Output Low Current	I _{OL}	V _{OL} @ MIN = 1.95 V, V _{OL} @ MAX = 0.4 V	30	38	mA	1
Rising Edge Slew Rate	t _{SLR}	Measured from 0.8 to 2.0 V	1	4	V/ns	1
Falling Edge Slew Rate	t _{FLR}	Measured from 2.0 to 0.8 V	1	4	V/ns	1
Duty Cycle	d _{tt}	V _T = 1.5 V	45	55	%	1
Jitter	t _{jcy-cyc}	V _T = 1.5 V		1000	ps	1

*TA = -40 - 85°C; Supply Voltage VDD = 3.3 V +/-5%, Rs = 39Ω, CL = 5pF

Electrical Characteristics - 27MHz_Spread / 27MHz_NonSpread

PARAMETER	SYMBOL	CONDITIONS	MIN	MAX	UNITS	Notes
Long Accuracy	ppm	see Tperiod min-max values	-50	50	ppm	1,6
Clock period	T_{period}	27.000MHz output nominal	37.0352	37.0389	ns	6
Output High Voltage	V_{OH}	$I_{OH} = -1 \text{ mA}$	2.4		V	1
Output Low Voltage	V_{OL}	$I_{OL} = 1 \text{ mA}$		0.55	V	1
Output High Current	I_{OH}	$V_{OH} @ \text{MIN} = 1.0 \text{ V}$	-29		mA	1
		$V_{OH} @ \text{MAX} = 3.135 \text{ V}$		-23	mA	1
Output Low Current	I_{OL}	$V_{OL} @ \text{MIN} = 1.95 \text{ V}$	29		mA	1
		$V_{OL} @ \text{MAX} = 0.4 \text{ V}$		27	mA	1
Edge Rate	$t_{slew/f}$	Rising/Falling edge rate	1	4	V/ns	1
Rise Time	t_{r1}	$V_{OL} = 0.4 \text{ V}, V_{OH} = 2.4 \text{ V}$	0.5	2	ns	1
Fall Time	t_{f1}	$V_{OH} = 2.4 \text{ V}, V_{OL} = 0.4 \text{ V}$	0.5	2	ns	1
Duty Cycle	d_{t1}	$V_T = 1.5 \text{ V}$	45	55	%	1
Jitter	t_{lj}	Long Term (10us), $V_T = 1.5 \text{ V}$		800	ps	1
	t_{jpk-pk}	$V_T = 1.5 \text{ V}$	-200	200	ps	1
	$t_{jvc-cyc}$	$V_T = 1.5 \text{ V}$		200	ps	1

*TA = -40 - 85°C; Supply Voltage VDD = 3.3 V +/-5%, Rs = 39Ω, CL = 5pF

Electrical Characteristics - Differential Jitter Parameters

PARAMETER	Symbol	Conditions	Min	TYP	Max	Units	Notes
Jitter, Phase	$t_{jphasePLL}$	PCIe Gen 1			86	ps (p-p)	1,11
	$t_{jphaseLo}$	PCIe Gen 2 10kHz < f < 1.5MHz			3	ps (RMS)	1,11
	$t_{jphaseHigh}$	PCIe Gen 2 1.5MHz < f < Nyquist (50MHz)			3.1	ps (RMS)	1,11

*TA = -40 - 85°C; Supply Voltage VDD = 3.3 V +/-5%, Rs= 0Ω, CL = 2pF

Notes on Electrical Characteristics:

¹Guaranteed by design and characterization, not 100% tested in production.

²Slew rate measured through Vswing centered around differential zero

³Vxabs is defined as the voltage where CLK = CLK#

⁴Only applies to the differential rising edge (CLK rising and CLK# falling)

⁵Defined as the total variation of all crossing voltages of CLK rising and CLK# falling. Matching applies to rising edge rate of CLK and falling edge of CLK#. It is measured using a +/-75mV window centered on the average cross point where CLK meets CLK#. The average cross point is used to calculate the voltage thresholds the oscilloscope is to use for the edge rate calculations.

⁶All Long Term Accuracy and Clock Period specifications are guaranteed assuming that REFOUT is at 14.31818MHz

⁷Operation under these conditions is neither implied, nor guaranteed.

⁸Maximum input voltage is not to exceed maximum VDD

⁹See PCI Clock-to-Clock Delay Figure

¹⁰At nominal voltage and temperature

¹¹See <http://www.pcisig.com> for complete specs

Figure 11. PCI Clock to Clock Delay

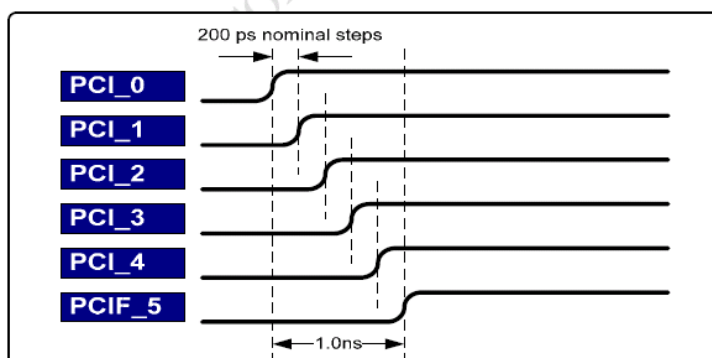

Table 1: CPU Frequency Select Table

FS _L C ² B0b7	FS _L B ¹ B0b6	FS _L A ¹ B0b5	CPU MHz	SRC MHz	PCI MHz	REF MHz	USB MHz	DOT MHz
0	0	0	266.66	100.00	33.33	14.318	48.00	96.00
0	0	1	133.33					
0	1	0	200.00					
0	1	1	166.66					
1	0	0	333.33					
1	0	1	100.00					
1	1	0	400.00					
1	1	1	Reserved					

- FS_LA and FS_LB are low-threshold inputs. Please see V_{IL_FS} and V_{IH_FS} specifications in the Input/Supply/Common Output Parameters Table for correct values. Also refer to the Test Clarification Table.
- FS_LC is a three-level input. Please see the V_{IL_FS} and V_{IH_FS} specifications in the Input/Supply/Common Output Parameters Table for correct values.

Table 2: 27FIX/LCDT/SRCT_LR1/SE1, 27SS/LCDC/SRCC_LR1/SE2 Configuration

27_SEL	B1b4	B1b3	B1b2	B1b1	27FIX/LCDT/SRCT_LR1/SE1	27SS/LCDC/SRCC_LR1/SE2	Spread %	Comment
					MHz	MHz		
0	0	0	0	0	PLL1 & PLL2 disabled			
0	0	0	0	1	100.00	100.00		SRCCLK1 from SRC_MAIN
0	0	0	1	0	100.00	100.00	-0.50%	LCDCLK from PLL1
0	0	0	1	1	100.00	100.00	-1%	LCDCLK from PLL1
0	0	1	0	0	100.00	100.00	-1.50%	LCDCLK from PLL1
0	0	1	0	1	100.00	100.00	+/-0.25%	LCDCLK from PLL1
0	0	1	1	0	100.00	100.00	+/-0.5%	LCDCLK from PLL1
0	0	1	1	1	N/A	N/A	N/A	N/A
0	1	0	0	0	24.576	24.576	None	24.576Mhz on SE1 and SE2
0	1	0	0	1	24.576	98.304	None	24.576Mhz on SE1, 98.304Mhz on SE2
0	1	0	1	0	98.304	98.304	None	98.304Mhz on SE1 and SE2
0	1	0	1	1	27.000	27.000	None	27Mhz on SE1 and SE2
0	1	1	0	0	25.000	25.000	None	25Mhz on SE1 and SE2
0	1	1	0	1				N/A
0	1	1	1	0	N/A	N/A	N/A	N/A
0	1	1	1	1	N/A	N/A	N/A	N/A
1	0	0	0	0	N/A	N/A	N/A	N/A
1	0	0	0	1	N/A	N/A	N/A	N/A
1	0	0	1	0	27MHz_nonSS	27MHz_SS	-0.5%	
1	0	0	1	1	27MHz_nonSS	27MHz_SS	-1%	
1	0	1	0	0	27MHz_nonSS	27MHz_SS	-1.5%	
1	0	1	0	1	27MHz_nonSS	27MHz_SS	-2%	
1	0	1	1	0	27MHz_nonSS	27MHz_SS	-0.75%	
1	0	1	1	1	27MHz_nonSS	27MHz_SS	-1.25%	
1	1	0	0	0	27MHz_nonSS	27MHz_SS	-1.75%	
1	1	0	0	1	27MHz_nonSS	27MHz_SS	+0.5%	
1	1	0	1	0	27MHz_nonSS	27MHz_SS	+0.75%	
1	1	0	1	1	N/A	N/A		
1	1	1	0	0	N/A	N/A		
1	1	1	1	0	N/A	N/A		
1	1	1	1	0	N/A	N/A		
1	1	1	1	1	N/A	N/A		

Note: Mode 00000 ~ 00110 on Table 2 only applies when SRC_MAIN source is from PLL5.

Table 3: IO_Vout select table

B9b2	B9b1	B9b0	IO_Vout
0	0	0	0.3V
0	0	1	0.4V
0	1	0	0.5V
0	1	1	0.6V
1	0	0	0.7V
1	0	1	0.8V
1	1	0	0.9V
1	1	1	1.0V

Table 4: Device ID table

B8b7	B8b6	B8b5	B8b4	Comment
0	0	0	0	9LRS3125BIK
0	0	0	1	Reserved
0	0	1	0	Reserved
0	0	1	1	Reserved
0	1	0	0	Reserved
0	1	0	1	Reserved
0	1	1	0	Reserved
0	1	1	1	Reserved
1	1	0	0	Reserved
1	1	0	1	Reserved
1	1	1	0	Reserved
1	1	1	1	Reserved
1	1	0	0	Reserved
1	1	0	1	Reserved
1	1	1	0	Reserved
1	1	1	1	Reserved

CPU Power Management Table

PD#	CPU_STOP#	PCI_STOP#	PEREQ#	SMBus Register OE	CPU0	CPU0#	CPU1	CPU1#	CPU2	CPU2#
1	1	1	X	Enable	Running	Running	Running	Running	Running	Running
0	X	X	X	Enable	Low/20K	Low	Low/20K	Low	Low/20K	Low
1	0	X	X	Enable	High	Low	High	Low	High	Low
1	X	X	X	Disable	Low/20K	Low	Low/20K	Low	Low/20K	Low
M1					Low/20K	Low	Running	Running	Low/20K	Low

PCIEX, LCD Power Management Table

PD#	CPU_STOP#	PCI_STOP#	PEREQ#	SMBus Register OE	PCIeT	PCIeC	PCIeT	PCIeC	LCD	LCD #	LCD	LCD #	SATA	SATA#	SATA	SATA#
					Free-Run		Stoppable		Free-Run		Stoppable		Free-Run		Stoppable	
1	X	1	0	Enable	Running	Running	Running	Running	Running	Running	Running	Running	Running	Running	Running	Running
0	X	X	X	Enable	Low/20K	Low	Low/20K	Low	Low/20K	Low	Low/20K	Low	Low/20K	Low	Low/20K	Low
1	X	0	0	Enable	Running	Running	High	Low	Running	Running	High	Low	Running	Running	High	Low
1	X	X	1	Enable	Running	Running	Low/20K	Low	Running	Running	Running	Running	Running	Running	Running	Running
1	X	X	X	Disable	Low/20K	Low	Low/20K	Low	Low/20K	Low	Low/20K	Low	Low/20K	Low	Low/20K	Low
M1					Low/20K	Low	Low/20K	Low	Low/20K	Low	Low/20K	Low	Low/20K	Low	Low/20K	Low

DOT Power Management Table

PD#	CPU_STOP#	PCI_STOP#	PEREQ#	SMBus Register OE	DOT	DOT#
1	X	1	X	Enable	Running	Running
0	X	X	X	Enable	Low/20K	Low
1	X	0	X	Enable	Running	Running
1	X	X	X	Enable	Running	Running
1	X	X	X	Disable	Low/20K	Low
M1					Low/20K	Low

Singled-Ended Power Management Table

PD#	CPU_STOP#	PCI_STOP#	PEREQ#	SMBus Register OE	PCIF/PCI Free-Run	PCIF/PCI Stoppable	USB48	REF	27M	SE
1	X	1	X	Enable	Running	Running	Running	Running	Running	Running
0	X	X	X	Enable	Low	Low	Low	Low	Low	Low
1	X	0	X	Enable	Running	Low	Running	Running	Running	Running
1	X	X	X	Disable	Low	Low	Low	Low	Low	Low
M1					Low	Low	Low	Low	Low	Low

Differential Clock Tolerances

	CPU	SRC	DOT96		
PPM tolerance	100	100	100		ppm
Cycle to Cycle Jitter	50	125	250		ps
Spread	-0.50%	-0.50%	0		%

Clock Periods - Differential Outputs with Spread Spectrum Disabled

SSC OFF	Center Freq. MHz	Measurement Window							Units	Notes
		1 Clock	1us	0.1s	0.1s	0.1s	1us	1 Clock		
		-c2c jitter AbsPer Min	-SSC Short-Term Average Min	- ppm Long-Term Average Min	0 ppm Period Nominal	+ ppm Long-Term Average Max	+SSC Short-Term Average Max	+c2c jitter		
CPU	100.00	9.94900		9.99900	10.00000	10.00100		10.05100	ns	1,2
	133.33	7.44925		7.49925	7.50000	7.50075		7.55075	ns	1,2
	166.67	5.94940		5.99940	6.00000	6.00060		6.05060	ns	1,2
	200.00	4.94950		4.99950	5.00000	5.00050		5.05050	ns	1,2
	266.67	3.69962		3.74962	3.75000	3.75037		3.80037	ns	1,2
	333.33	2.94970		2.99970	3.00000	3.00030		3.05030	ns	1,2
	400.00	2.44975		2.49975	2.50000	2.50025		2.55025	ns	1,2
SRC	100.00	9.87400	9.99900	10.00000	10.00100	10.12600	ns	1,2		
DOT96	96.00	10.16563	10.41563	10.41667	10.41771	10.66771	ns	1,2		

Clock Periods - Differential Outputs with Spread Spectrum Enabled

SSC ON	Center Freq. MHz	Measurement Window							Units	Notes
		1 Clock	1us	0.1s	0.1s	0.1s	1us	1 Clock		
		-c2c jitter AbsPer Min	-SSC Short-Term Average Min	- ppm Long-Term Average Min	0 ppm Period Nominal	+ ppm Long-Term Average Max	+SSC Short-Term Average Max	+c2c jitter		
CPU	99.75	9.94906	9.99906	10.02406	10.02506	10.02607	10.05107	10.10107	ns	1,2
	133.00	7.44930	7.49930	7.51805	7.51880	7.51955	7.53830	7.58830	ns	1,2
	166.25	5.94944	5.99944	6.01444	6.01504	6.01564	6.03064	6.08064	ns	1,2
	199.50	4.94953	4.99953	5.01203	5.01253	5.01303	5.02553	5.07553	ns	1,2
	266.00	3.69965	3.74965	3.75902	3.75940	3.75977	3.76915	3.81915	ns	1,2
	332.50	2.94972	2.99972	3.00722	3.00752	3.00782	3.01532	3.06532	ns	1,2
	399.00	2.44977	2.49977	2.50602	2.50627	2.50652	2.51277	2.56277	ns	1,2
SRC	99.75	9.87406	9.99906	10.02406	10.02506	10.02607	10.05107	10.17607	ns	1,2

¹Guaranteed by design and characterization, not 100% tested in production.

²All Long Term Accuracy specifications are guaranteed with the assumption that the crystal input is tuned to exactly 14.31818MHz.

General SMBus serial interface information for the ICS9ERS3125

How to Write:

- Controller (host) sends a start bit.
- Controller (host) sends the write address $D2_{(H)}$
- ICS clock will **acknowledge**
- Controller (host) sends the beginning byte location = N
- ICS clock will **acknowledge**
- Controller (host) sends the data byte count = X
- ICS clock will **acknowledge**
- Controller (host) starts sending **Byte N through Byte N + X - 1**
- ICS clock will **acknowledge** each byte **one at a time**
- Controller (host) sends a Stop bit

How to Read:

- Controller (host) will send start bit.
- Controller (host) sends the write address $D2_{(H)}$
- ICS clock will **acknowledge**
- Controller (host) sends the beginning byte location = N
- ICS clock will **acknowledge**
- Controller (host) will send a separate start bit.
- Controller (host) sends the read address $D3_{(H)}$
- ICS clock will **acknowledge**
- ICS clock will send the data byte count = X
- ICS clock sends **Byte N + X - 1**
- ICS clock sends **Byte 0 through byte X (if $X_{(H)}$ was written to byte 8).**
- Controller (host) will need to acknowledge each byte
- Controller (host) will send a not acknowledge bit
- Controller (host) will send a stop bit

Index Block Write Operation		
Controller (Host)		ICS (Slave/Receiver)
T	starT bit	
Slave Address $D2_{(H)}$		
WR	WRite	
		ACK
Beginning Byte = N		
		ACK
Data Byte Count = X		
		ACK
Beginning Byte N		X Byte
○		
○		
○		
Byte N + X - 1		
		ACK
P	stoP bit	

Index Block Read Operation		
Controller (Host)		ICS (Slave/Receiver)
T	starT bit	
Slave Address $D2_{(H)}$		
WR	WRite	
		ACK
Beginning Byte = N		
		ACK
RT	Repeat starT	
Slave Address $D3_{(H)}$		
RD	ReaD	
		ACK
		Data Byte Count = X
ACK		X Byte
ACK		
○		
○		
○		
		Byte N + X - 1
N	Not acknowledge	
P	stoP bit	

Byte 0 FS Readback & PLL Selection Register

Bit	Name	Description	Type	0	1	Default
7	FSLC	CPU Freq. Sel. Bit (Most Significant)	R	See Table 1 : CPU Frequency Select Table		Latch
6	FSLB	CPU Freq. Sel. Bit	R			Latch
5	FSLA	CPU Freq. Sel. Bit (Least Significant)	R			Latch
4	iAMT_EN	Set via SMBus or dynamically by CK505 if detects dynamic M1	R	Legacy Mode	iAMT Enabled	iAMT power on status
3	Reserved					1
2	SRC_Main_SEL	Select source for SRC Main	RW	SRC Main = PLL5	SRC Main = PLL2	0
1	SATA_SEL	Select source for SATA clock	RW	SATA = SRC_Main	SATA = PLL3	0
0	PD_Restore	1 = on Power Down de-assert return to last known state 0 = clear all SMBus configurations as if cold power-on and go to latches open state This bit is ignored and treated at '1' if device is in iAMT mode.	RW	Configuration Not Saved	Configuration Saved	1

Byte 1 DOT96 Select & PLL3 Quick Config Register,**Note 1 : When 27_Select pin = 0, B1b7 Default = 1; When 27_Select pin = 1, Default = 0**

Bit	Name	Description	Type	0	1	Default
7	SRC0_SEL	Select SRC0 or DOT96	RW	SRC0	DOT96	Note 1
6	PLL5_SSC_SEL	Select 0.5% down or center SSC	RW	Down spread	Center spread	0
5	PLL2_SSC_SEL	Select 0.5% center or down SSC	RW	Down	Center	0
4	PLL1_CF3	PLL1 Quick Config Bit 3	RW	See Table 2: pin 27FIX/LCDT/SRCT_LR1/SE1, 27SS/LCDC/SRCC_LR1/SE2 Configuration Only applies if Byte 0, bit 2 = 0.		0
3	PLL1_CF2	PLL1 Quick Config Bit 2	RW			0
2	PLL1_CF1	PLL1 Quick Config Bit 1	RW			1
1	PLL1_CF0	PLL1 Quick Config Bit 0	RW			0
0	PCI_SEL	PCI_SEL	RW	PCI from PLL5	PCI from SRC_MAIN	1

Byte 2 Single Ended Output Enable Register

Bit	Name	Description	Type	0	1	Default
7	REF_OE	Output enable for USB	RW	Output Disabled	Output Enabled	1
6	USB_OE	Output enable for USB	RW	Output Disabled	Output Enabled	1
5	PCIF5_OE	Output enable for PCI5	RW	Output Disabled	Output Enabled	1
4	PCI4_OE	Output enable for PCI4	RW	Output Disabled	Output Enabled	1
3	PCI3_OE	Output enable for PCI3	RW	Output Disabled	Output Enabled	1
2	PCI2_OE	Output enable for PCI2	RW	Output Disabled	Output Enabled	1
1	PCI1_OE	Output enable for PCI1	RW	Output Disabled	Output Enabled	1
0	PCI0_OE	Output enable for PCI0	RW	Output Disabled	Output Enabled	1

Byte 3 SRC Output Enable Register

Bit	Name	Description	Type	0	1	Default
7	SRC11_OE	Output enable for SRC11	RW	Output Disabled	Output Enabled	1
6	Reserved					1
5	Reserved					1
4	SRC8/ITP_OE	Output enable for SRC8 or ITP	RW	Output Disabled	Output Enabled	1
3	SRC7_OE	Output enable for SRC7	RW	Output Disabled	Output Enabled	1
2	SRC6_OE	Output enable for SRC6	RW	Output Disabled	Output Enabled	1
1	Reserved					1
0	SRC4_OE	Output enable for SRC4	RW	Output Disabled	Output Enabled	1

Byte 4 SRC/CPU/DOT Output Enable & Spread Spectrum Disable Register

Bit	Name	Description	Type	0	1	Default
7	SRC3_OE	Output enable for SRC3	RW	Output Disabled	Output Enabled	1
6	SATA/SRC2_OE	Output enable for SATA/SRC2	RW	Output Disabled	Output Enabled	1
5	SRC1_OE	Output enable for SRC1	RW	Output Disabled	Output Enabled	1
4	SRC0/DOT96_OE	Output enable for SRC0/DOT96	RW	Output Disabled	Output Enabled	1
3	CPU1_OE	Output enable for CPU1	RW	Output Disabled	Output Enabled	1
2	CPU0_OE	Output enable for CPU0	RW	Output Disabled	Output Enabled	1
1	PLL5_SSC_ON	Enable PLL5's spread modulation	RW	Spread Disabled	Spread Enabled	1
0	PLL2_SSC_ON	Enable PLL2's spread modulation	RW	Spread Disabled	Spread Enabled	1

Byte 5 Clock Request Enable/Configuration Register

Bit	Name	Description	Type	0	1	Default
7	CR#_A_EN	Enable CR#_A (clk req) for SRC0 or SRC2	RW	Disable CR#_A	Enable CR#_A	0
6	CR#_A_SEL	Sets CR#_A to control either SRC0 or SRC2	RW	CR#_A -> SRC0	CR#_A -> SRC2	0
5	CR#_B_EN	Enable CR#_B (clk req) for SRC1 or SRC4	RW	Disable CR#_B	Enable CR#_B	0
4	CR#_B_SEL	Sets CR#_B to control either SRC1 or SRC4	RW	CR#_B -> SRC1	CR#_B -> SRC4	0
3	CR#_C_EN	Enable CR#_C (clk req) for SRC0 or SRC2	RW	Disable CR#_C	Enable CR#_C	0
2	CR#_C_SEL	Sets CR#_C to control either SRC0 or SRC2	RW	CR#_C -> SRC0	CR#_C -> SRC2	0
1	CR#_D_EN	Enable CR#_D (clk req) for SRC1 or SRC4	RW	Disable CR#_D	Enable CR#_D	0
0	CR#_D_SEL	Sets CR#_D to control either SRC1 or SRC4	RW	CR#_D -> SRC1	CR#_D -> SRC4	0

Byte 6 Clock Request Enable/Configuration Register

Bit	Name	Description	Type	0	1	Default
7	CR#_E_EN	Enable CR#_E (clk req) for SRC6	RW	Disable CR#_E	Enable CR#_E	0
6	CR#_F_EN	Enable CR#_F (clk req) for SRC8	RW	Disable CR#_F	Enable CR#_F	0
5		Reserved				0
4		Reserved				0
3		Reserved				0
2		Reserved				0
1	LCD/SRC1_STP_CRTL*	If set, LCD_SS/SRC1 stops with PCI_STOP#	RW	Free Running	Stops with PCI_STOP# assertion	0
0	SRC0_STP_CRTL	If set, SRC0 stop with PCI_STOP#	RW	Free Running	Stops with PCI_STOP# assertion	0

Byte 7 Vendor ID/ Revision ID Register

Bit	Name	Description	Type	0	1	Default
7	Rev Code Bit 3	Revision ID	R	Vendor specific		0
6	Rev Code Bit 2		R			0
5	Rev Code Bit 1		R			0
4	Rev Code Bit 0		R			1
3	Vendor ID bit 3	Vendor ID ICS is 0001, binary	R			0
2	Vendor ID bit 2		R			0
1	Vendor ID bit 1		R			0
0	Vendor ID bit 0		R	1		

Byte 8 Device ID & Output Enable Register

Bit	Name	Description	Type	0	1	Default (MLF)
7	Device_ID3	Table of Device identifier codes, used for differentiating between CK505 package options, etc.	R	See Device ID Table 4		0
6	Device_ID2		R			0
5	Device_ID1		R			0
4	Device_ID0		R			0
3		Reserved				0
2		Reserved				0
1	27MHz_nonSS/SE1_OE	Output enable for SE1	RW	Disabled	Enabled	1
0	27MHz_SS/SE2_OE	Output enable for SE2	RW	Disabled	Enabled	1

Byte 9 Test and Output Control Register

Bit	Name	Description	Type	0	1	Default
7	PCIF5_STOP_EN	Allows control of PCIF5 with assertion of PCI_STOP#	RW	Free running	Stops with PCI_STOP# assertion	0
6	TME_Readback	Trusted Mode Enable (TME) strap status	R	normal operation	no overclocking	TME latch
5		Reserved				1
4	Test Mode Select	Allows test select, ignores REF/FSC/TestSel	RW	Outputs HI-Z	Outputs = REF/N	0
3	Test Mode Entry	Allows entry into test mode, ignores FSB/TestMode	RW	Normal operation	Test mode	0
2	CPU_IO_VOUT2	CPU IO Output Voltage Select (Most Significant Bit)	RW	See Table 3: V_IO Selection (Default is 0.8V)		1
1	CPU_IO_VOUT1	CPU IO Output Voltage Select	RW			0
0	CPU_IO_VOUT0	CPU IO Output Voltage Select (Least Significant Bit)	RW			1

Byte 10 Output Control Register

Bit	Name	Description	Type	0	1	Default
7	27_SEL Latch Readback	Readback of 27_Select latch	R	Dot96/ LCD_SS /SE	SRC0/ 27MHz	27_SEL latch
6	PCI4 STOP EN	Allows control of PCI4 with assertion of PCI_STOP#	RW	Free running	Stops with PCI_STOP# assertion	1
5	PCI3 STOP EN	Allows control of PCI3 with assertion of PCI_STOP#	RW	Free running	Stops with PCI_STOP# assertion	1
4	PCI2 STOP EN	Allows control of PCI2 with assertion of PCI_STOP#	RW	Free running	Stops with PCI_STOP# assertion	1
3	PCI1 STOP EN	Allows control of PCI1 with assertion of PCI_STOP#	RW	Free running	Stops with PCI_STOP# assertion	1
2	PCI0 STOP EN	Allows control of PCI0 with assertion of PCI_STOP#	RW	Free running	Stops with PCI_STOP# assertion	1
1	CPU1 Stop Enable	Enables control of CPU1 with CPU_STOP#	RW	Free Running	Stoppable	1
0	CPU0 Stop Enable	Enables control of CPU0 with CPU_STOP#	RW	Free Running	Stoppable	1

Byte 11 iAMT/CPU2 Control Register

Bit	Name	Description	Type	0	1	Default
7		Reserved				0
6		Reserved				0
5		Reserved				0
4		Reserved				0
3	CPU2_AMT_EN	M1 mode clk enable, only if ITP_EN=1	RW	Disable	Enable	0
2	CPU1_AMT_EN	M1 mode clk enable	RW	Disable	Enable	1
1	Reserved	Reserved	RW	-	-	0
0	CPU2 Stop Enable	Enables control of CPU2 with CPU_STOP#	RW	Free Running	Stoppable	1

Byte 12 Byte Count Register

Bit	Name	Description	Type	0	1	Default
7		Reserved				0
6		Reserved				0
5	BC5	Read Back byte count register, max bytes = 32	RW	-	-	0
4	BC4		RW	-	-	0
3	BC3		RW	-	-	1
2	BC2		RW	-	-	1
1	BC1		RW	-	-	0
0	BC0		RW	-	-	1

Byte 13 Single Ended Output Slew Rate Control Register

Bit	Name	Description	RW	0	1	Default
7	REF	Slew Rate Control	RW	00 = Hi-Z	01 = 1.4 V/ns	0
6	REF		RW	10 = 2.0 V/ns	11 = 2.4 V/ns	1
5	27M_FIX	Slew Rate Control	RW	00 = Hi-Z	01 = 1.4 V/ns	0
4	27M_FIX		RW	10 = 2.0 V/ns	11 = 2.4 V/ns	1
3	27M_SS	Slew Rate Control	RW	00 = Hi-Z	01 = 1.4 V/ns	0
2	27M_SS		RW	10 = 2.0 V/ns	11 = 2.4 V/ns	1
1		Reserved				0
0		Reserved				0

Byte 14 Reserved

Bit	Name	Description	Type	0	1	Default
7		Reserved				X
6		Reserved				X
5		Reserved				X
4		Reserved				X
3		Reserved				X
2		Reserved				X
1		Reserved				X
0		Reserved				X

Byte 15 Reserved

Bit	Name	Description	Type	0	1	Default
7		Reserved				X
6		Reserved				X
5		Reserved				X
4		Reserved				X
3		Reserved				X
2		Reserved				X
1		Reserved				X
0		Reserved				X

Byte 16 Reserved

Bit	Name	Description	Type	0	1	Default
7		Reserved				X
6		Reserved				X
5		Reserved				X
4		Reserved				X
3		Reserved				X
2		Reserved				X
1		Reserved				X
0		Reserved				X

Byte 17 SRC Output Control Register

Bit	Name	Description	RW	0	1	Default
7	SATA/SRC2_STP_CTRL	If set, SATA/SRC2 stops with PCI_STOP#	RW	Free Running	Stops with PCI_STOP# assertion	0
6	SRC3_STP_CTRL	If set, SRC3 stops with PCI_STOP#	RW	Free Running	Stops with PCI_STOP# assertion	0
5	SRC4_STP_CTRL	If set, SRC4 stops with PCI_STOP#	RW	Free Running	Stops with PCI_STOP# assertion	0
4	SRC6_STP_CTRL	If set, SRC6 stops with PCI_STOP#	RW	Free Running	Stops with PCI_STOP# assertion	0
3	SRC7_STP_CTRL	If set, SRC7 stops with PCI_STOP#	RW	Free Running	Stops with PCI_STOP# assertion	0
2		Reserved				0
1	SRC8_STP_CTRL	If set, SRC8 stops with PCI_STOP#	RW	Free Running	Stops with PCI_STOP# assertion	0
0		Reserved				0

Byte 18 Differential Output Control Register

Bit	Name	Description	RW	0	1	Default
7		Reserved				0
6	SRC11_STP_CTRL	If set, SRC11 stops with PCI_STOP#	RW	Free Running	Stops with PCI_STOP# assertion	0
5	SRC/CPUITP_SRC8 IO_VOUT2	SRC & CPUITP_SRC8 IO Output Voltage Select (Most Significant Bit)	RW	See Table 3: V_IO Selection (Default is 0.8V)		1
4	SRC/CPUITP_SRC8 IO_VOUT1	SRC IO & CPUITP_SRC8 Output Voltage Select	RW			0
3	SRC/CPUITP_SRC8 IO_VOUT0	SRC & CPUITP_SRC8 IO Output Voltage Select (Least Significant Bit)	RW			1
2	SATA/SRC2 IO_VOUT2	SATA_SRC2 IO Output Voltage Select (Most Significant Bit)	RW	See Table 3: V_IO Selection (Default is 0.8V)		1
1	SATA/SRC2 IO_VOUT1	SATA_SRC2 IO Output Voltage Select	RW			0
0	SATA/SRC2 IO_VOUT0	SATA_SRC2 IO Output Voltage Select (Least Significant Bit)	RW			1

Byte 19 Differential Output Control Register

Bit	Name	Description	RW	0	1	Default
7	LCD_SS (SRC1) IO_VOUT2	LCD_SS IO Output Voltage Select (Most Significant Bit)	RW	See Table 3: V_IO Selection (Default is 0.8V)		1
6	LCD_SS (SRC1) IO_VOUT1	LCD_SS IO Output Voltage Select	RW			0
5	LCD_SS (SRC1) IO_VOUT0	LCD_SS IO Output Voltage Select (Least Significant Bit)	RW			1
4	SRC0/DOT96 IO_VOUT2	SRC0_DOT96 IO Output Voltage Select (Most Significant Bit)	RW	See Table 3: V_IO Selection (Default is 0.8V)		1
3	SRC0/DOT96 IO_VOUT1	SRC0_DOT96 IO Output Voltage Select	RW			0
2	SRC0/DOT96 IO_VOUT0	SRC0_DOT96 IO Output Voltage Select (Least Significant Bit)	RW			1
1		Reserved				0
0		Reserved				0

Byte 20 Single Ended Slew Rate Control Register

Bit	Name	Description	Type	0	1	Default
7	48MHz	Slew Rate Control	RW	00 = Hi-Z	01 = 1.4 V/ns	0
6	48MHz		RW	10 = 2.0 V/ns	11 = 2.4 V/ns	1
5	PCIF5	Slew Rate Control	RW	00 = Hi-Z	01 = 1.4 V/ns	0
4	PCIF5		RW	10 = 2.0 V/ns	11 = 2.4 V/ns	1
3	PCI4	Slew Rate Control	RW	00 = Hi-Z	01 = 1.4 V/ns	0
2	PCI4		RW	10 = 2.0 V/ns	11 = 2.4 V/ns	1
1	PCI3	Slew Rate Control	RW	00 = Hi-Z	01 = 1.4 V/ns	0
0	PCI3		RW	10 = 2.0 V/ns	11 = 2.4 V/ns	1

Byte 21 Single Ended Slew Rate & M/N Enable Control Register

Bit	Name	Description	Type	0	1	Default
7	PCI2	Slew Rate Control	RW	00 = Hi-Z	01 = 1.4 V/ns	0
6	PCI2		RW	10 = 2.0 V/ns	11 = 2.4 V/ns	1
5	PCI1	Slew Rate Control	RW	00 = Hi-Z	01 = 1.4 V/ns	0
4	PCI1		RW	10 = 2.0 V/ns	11 = 2.4 V/ns	1
3	PCI0	Slew Rate Control	RW	00 = Hi-Z	01 = 1.4 V/ns	0
2	PCI0		RW	10 = 2.0 V/ns	11 = 2.4 V/ns	1
1		Reserved				0
0		Reserved				0

Test Clarification Table

Comments	HW		SW		OUTPUT
	FSLC/ TEST_SEL HW PIN	FSLB/ TEST_MODE HW PIN	TEST ENTRY BIT B9b3	REF/N or HI-Z B9b4	
	<2.0V	X	0	0	NORMAL
	>2.0V	0	X	0	HI-Z
CK_PWRG=1 w/ TEST_SEL = 1 to enter test mode Cycle power to disable test mode FSLC./TEST_SEL -->3-level latched input If CK_PWRG=1 w/ V>2.0V then use TEST_SEL If CK_PWRG=1 w/ V<2.0V then use FSLC FSLB/TEST_MODE -->low Vth input TEST_MODE is a real time input	>2.0V	0	X	1	REF/N
	>2.0V	1	X	0	REF/N
	>2.0V	1	X	1	REF/N
	<2.0V	X	1	0	HI-Z
If TEST_SEL HW pin is 0 after CK_PWRG=1, test mode can be invoked through B9b3. If test mode is invoked by B9b3, only B9b4 is used to select HI-Z or REF/N FSLB/TEST_Mode pin is not used. Cycle power to disable test mode, one shot control	<2.0V	X	1	1	REF/N
	<2.0V	X	1	1	REF/N

B9b3: 1= ENTER TEST MODE, Default = 0 (NORMAL OPERATION)

B9b4: 1= REF/N, Default = 0 (HI-Z)

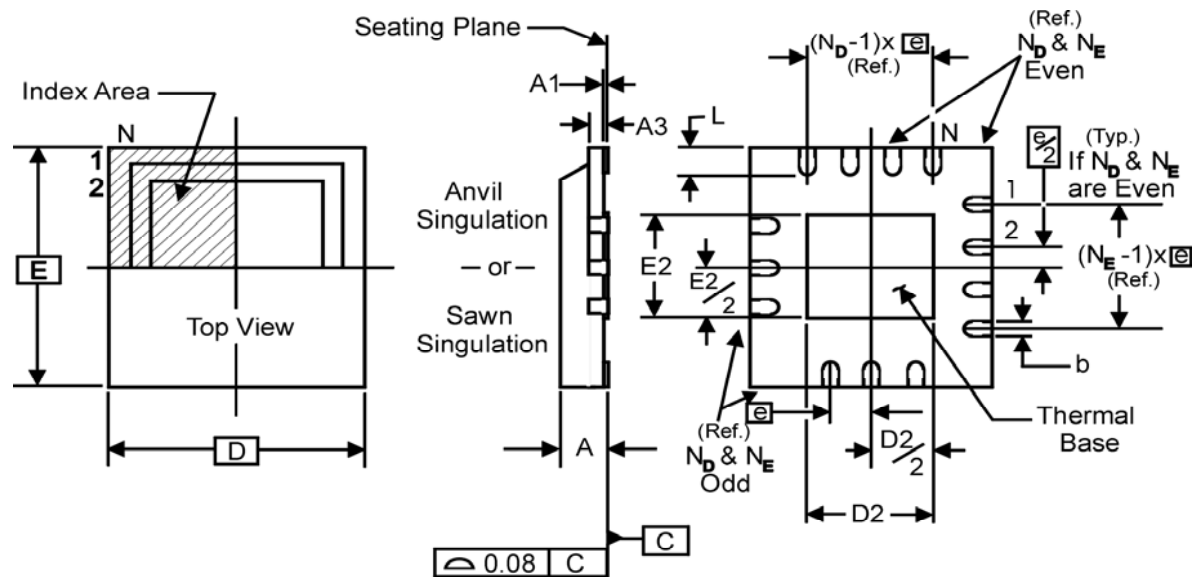

**THERMALLY ENHANCED, VERY THIN, FINE PITCH
QUAD FLAT / NO LEAD PLASTIC PACKAGE**

DIMENSIONS

SYMBOL	56L
N	56
N _D	14
N _E	14

DIMENSIONS (mm)

SYMBOL	MIN.	MAX.
A	0.8	1.0
A1	0	0.05
A3	0.25 Reference	
b	0.18	0.3
e	0.50 BASIC	
D x E BASIC	8.00 x 8.00	
D2 MIN. / MAX.	4.35	4.65
E2 MIN. / MAX.	5.05	5.35
L MIN. / MAX.	0.3	0.5

Ordering Information

Part/Order Number	Shipping Packaging	Package	Temperature
9ERS3125BKILF	Tubes	56-pin MLF	-40 to +85° C
9ERS3125BKILFT	Tape and Reel	56-pin MLF	-40 to +85° C

Parts that are ordered with a "LF" suffix to the part number are the Pb-Free configuration and are RoHS compliant. Due to package size constraints, actual top-side marking may differ from the full orderable part number.

Revision History

Rev.	Issue Date	Description	Page #
0.1	07/31/09	Initial Release	-
A	08/19/09	Released to final	

This product is protected by United States Patent NO. 7,342,420 and other patents.

IMPORTANT NOTICE AND DISCLAIMER

RENESAS ELECTRONICS CORPORATION AND ITS SUBSIDIARIES (“RENESAS”) PROVIDES TECHNICAL SPECIFICATIONS AND RELIABILITY DATA (INCLUDING DATASHEETS), DESIGN RESOURCES (INCLUDING REFERENCE DESIGNS), APPLICATION OR OTHER DESIGN ADVICE, WEB TOOLS, SAFETY INFORMATION, AND OTHER RESOURCES “AS IS” AND WITH ALL FAULTS, AND DISCLAIMS ALL WARRANTIES, EXPRESS OR IMPLIED, INCLUDING, WITHOUT LIMITATION, ANY IMPLIED WARRANTIES OF MERCHANTABILITY, FITNESS FOR A PARTICULAR PURPOSE, OR NON-INFRINGEMENT OF THIRD-PARTY INTELLECTUAL PROPERTY RIGHTS.

These resources are intended for developers who are designing with Renesas products. You are solely responsible for (1) selecting the appropriate products for your application, (2) designing, validating, and testing your application, and (3) ensuring your application meets applicable standards, and any other safety, security, or other requirements. These resources are subject to change without notice. Renesas grants you permission to use these resources only to develop an application that uses Renesas products. Other reproduction or use of these resources is strictly prohibited. No license is granted to any other Renesas intellectual property or to any third-party intellectual property. Renesas disclaims responsibility for, and you will fully indemnify Renesas and its representatives against, any claims, damages, costs, losses, or liabilities arising from your use of these resources. Renesas' products are provided only subject to Renesas' Terms and Conditions of Sale or other applicable terms agreed to in writing. No use of any Renesas resources expands or otherwise alters any applicable warranties or warranty disclaimers for these products.

(Disclaimer Rev.1.01 Jan 2024)

Corporate Headquarters

TOYOSU FORESIA, 3-2-24 Toyosu,
Koto-ku, Tokyo 135-0061, Japan
www.renesas.com

Trademarks

Renesas and the Renesas logo are trademarks of Renesas Electronics Corporation. All trademarks and registered trademarks are the property of their respective owners.

Contact Information

For further information on a product, technology, the most up-to-date version of a document, or your nearest sales office, please visit www.renesas.com/contact-us/.