

Frequency Generator for P4™ CPU, PCI Express™ & Fully Buffered DIMM Clocks

Recommended Application:

DB1900G: CPU Host Bus, PCI Express and Fully-Buffered DIMM clocking

Features:

- Power up default is all outputs in 1:1 mode
- DIF_(16:0) can be “gear-shifted” from the input CPU Host Clock
- DIF_(18:17) can be “gear-shifted” from the input CPU Host Clock
- Spread spectrum compatible
- Supports output clock frequencies up to 400 MHz
- 8 Selectable SMBus addresses
- SMBus address determines PLL or Bypass mode
- VDDA controlled power down mode

Key Specifications:

- DIF output cycle-to-cycle jitter < 50ps
- DIF (0:18) output-to-output skew < 225ps
- DIF (0:16) output-to-output skew < 100ps

Functionality at Power Up (PLL Mode)

FS_A_410 ¹	CLK_IN (CPU FSB) MHz	DIF_(18:0) MHz
1	100 <= CLK_IN < 200	CLK_IN
0	200 <= CLK_IN <= 400	CLK_IN

1. FS_A_410 is a low-threshold input. Please see the V_{IL,FS} and V_{IH,FS} specifications in the Input/Supply/Common Output Parameters Table for correct values.

Power Down Functionality

INPUTS		OUTPUTS		PLL State
VDDA/PD#	CLK_IN/CLK_IN#	DIF	DIF#	
3.3V (NOM)	Running	Running		ON
GND	X	Hi-Z		OFF

Functionality Note

It is recommended that Byte 2, bit 6 be toggled from 1 to 0 and back to 1, the first time VDDA is applied. This ensures proper initialization of the device.

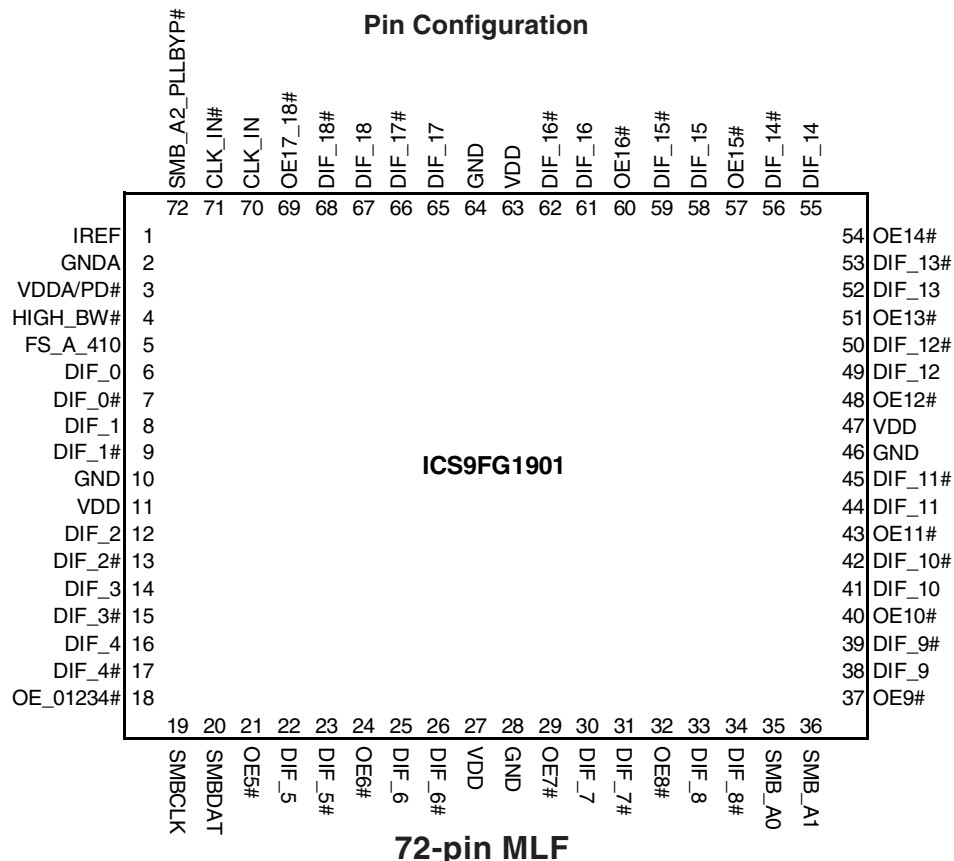

Pin Description

PIN #	PIN NAME	PIN TYPE	DESCRIPTION
1	IREF	OUT	This pin establishes the reference current for the differential current-mode output pairs. This pin requires a fixed precision resistor tied to ground in order to establish the appropriate current. 475 ohms is the standard value.
2	GNDA	PWR	Ground pin for the PLL core.
3	VDDA/PD#	PWR	3.3V power for the PLL core that also functions as Power Down. Collapsing this power supply places the device in Power Down mode.
4	HIGH_BW#	IN	3.3V input for selecting PLL Band Width 0 = High, 1 = Low
5	FS_A_410	IN	3.3V tolerant low threshold input for CPU frequency selection. This pin requires CK410 FSA. Refer to input electrical characteristics for Vil_FS and Vih_FS threshold values.
6	DIF_0	OUT	0.7V differential true clock output
7	DIF_0#	OUT	0.7V differential complement clock output
8	DIF_1	OUT	0.7V differential true clock output
9	DIF_1#	OUT	0.7V differential complement clock output
10	GND	PWR	Ground pin.
11	VDD	PWR	Power supply, nominal 3.3V
12	DIF_2	OUT	0.7V differential true clock output
13	DIF_2#	OUT	0.7V differential complement clock output
14	DIF_3	OUT	0.7V differential true clock output
15	DIF_3#	OUT	0.7V differential complement clock output
16	DIF_4	OUT	0.7V differential true clock output
17	DIF_4#	OUT	0.7V differential complement clock output
18	OE_01234#	IN	Active low input for enabling DIF pairs 0, 1, 2, 3 and 4. 1 = tri-state outputs, 0 = enable outputs
19	SMBCLK	IN	Clock pin of SMBUS circuitry, 5V tolerant
20	SMBDAT	I/O	Data pin of SMBUS circuitry, 5V tolerant
21	OE5#	IN	Active low input for enabling DIF pair 5. 1 = tri-state outputs, 0 = enable outputs
22	DIF_5	OUT	0.7V differential true clock output
23	DIF_5#	OUT	0.7V differential complement clock output
24	OE6#	IN	Active low input for enabling DIF pair 6. 1 = tri-state outputs, 0 = enable outputs
25	DIF_6	OUT	0.7V differential true clock output
26	DIF_6#	OUT	0.7V differential complement clock output
27	VDD	PWR	Power supply, nominal 3.3V
28	GND	PWR	Ground pin.
29	OE7#	IN	Active low input for enabling DIF pair 7. 1 = tri-state outputs, 0 = enable outputs
30	DIF_7	OUT	0.7V differential true clock output
31	DIF_7#	OUT	0.7V differential complement clock output
32	OE8#	IN	Active low input for enabling DIF pair 8. 1 = tri-state outputs, 0 = enable outputs
33	DIF_8	OUT	0.7V differential true clock output
34	DIF_8#	OUT	0.7V differential complement clock output
35	SMB_A0	IN	SMBus address bit 0 (LSB)
36	SMB_A1	IN	SMBus address bit 1

Pin Description (Continued)

PIN #	PIN NAME	PIN TYPE	DESCRIPTION
37	OE9#	IN	Active low input for enabling DIF pair 9. 1 = tri-state outputs, 0 = enable outputs
38	DIF_9	OUT	0.7V differential true clock output
39	DIF_9#	OUT	0.7V differential complement clock output
40	OE10#	IN	Active low input for enabling DIF pair 10. 1 = tri-state outputs, 0 = enable outputs
41	DIF_10	OUT	0.7V differential true clock output
42	DIF_10#	OUT	0.7V differential complement clock output
43	OE11#	IN	Active low input for enabling DIF pair 11. 1 = tri-state outputs, 0 = enable outputs
44	DIF_11	OUT	0.7V differential true clock output
45	DIF_11#	OUT	0.7V differential complement clock output
46	GND	PWR	Ground pin.
47	VDD	PWR	Power supply, nominal 3.3V
48	OE12#	IN	Active low input for enabling DIF pair 12. 1 = tri-state outputs, 0 = enable outputs
49	DIF_12	OUT	0.7V differential true clock output
50	DIF_12#	OUT	0.7V differential complement clock output
51	OE13#	IN	Active low input for enabling DIF pair 13. 1 = tri-state outputs, 0 = enable outputs
52	DIF_13	OUT	0.7V differential true clock output
53	DIF_13#	OUT	0.7V differential complement clock output
54	OE14#	IN	Active low input for enabling DIF pair 14. 1 = tri-state outputs, 0 = enable outputs
55	DIF_14	OUT	0.7V differential true clock output
56	DIF_14#	OUT	0.7V differential complement clock output
57	OE15#	IN	Active low input for enabling DIF pair 15. 1 = tri-state outputs, 0 = enable outputs
58	DIF_15	OUT	0.7V differential true clock output
59	DIF_15#	OUT	0.7V differential complement clock output
60	OE16#	IN	Active low input for enabling DIF pair 16. 1 = tri-state outputs, 0 = enable outputs
61	DIF_16	OUT	0.7V differential true clock output
62	DIF_16#	OUT	0.7V differential complement clock output
63	VDD	PWR	Power supply, nominal 3.3V
64	GND	PWR	Ground pin.
65	DIF_17	OUT	0.7V differential true clock output
66	DIF_17#	OUT	0.7V differential complement clock output
67	DIF_18	OUT	0.7V differential true clock output
68	DIF_18#	OUT	0.7V differential complement clock output
69	OE17_18#	IN	Active low input for enabling DIF pairs 17 and 18. 1 = tri-state outputs, 0 = enable outputs
70	CLK_IN	IN	Input for reference clock.
71	CLK_IN#	IN	"Complementary" reference clock input.
72	SMB_A2_PLLBYP#	IN	SMBus address bit 2. When Low, the part operates as a fanout buffer with the PLL bypassed. When High, the part operates as a zero-delay buffer (ZDB) with the PLL operating. 0 = fanout mode (PLL bypassed), 1 = ZDB mode (PLL used)

General Description

The **ICS9FG1901** follows the Intel DB1900G Differential Buffer Specification. This buffer provides 19 output clocks for CPU Host Bus, PCI-Express, or Fully Buffered DIMM applications. The outputs are configured with two groups. Both groups, DIF_(16:0) and DIF_(18:17) can be equal to or have a gear ratio to the input clock. A differential CPU clock from a CK410 or CK410B main clock generator, such as the ICS954101 or ICS932S401, drives the **ICS9FG1901**. The **ICS9FG1901** can provide outputs up to 400MHz.

Block Diagram

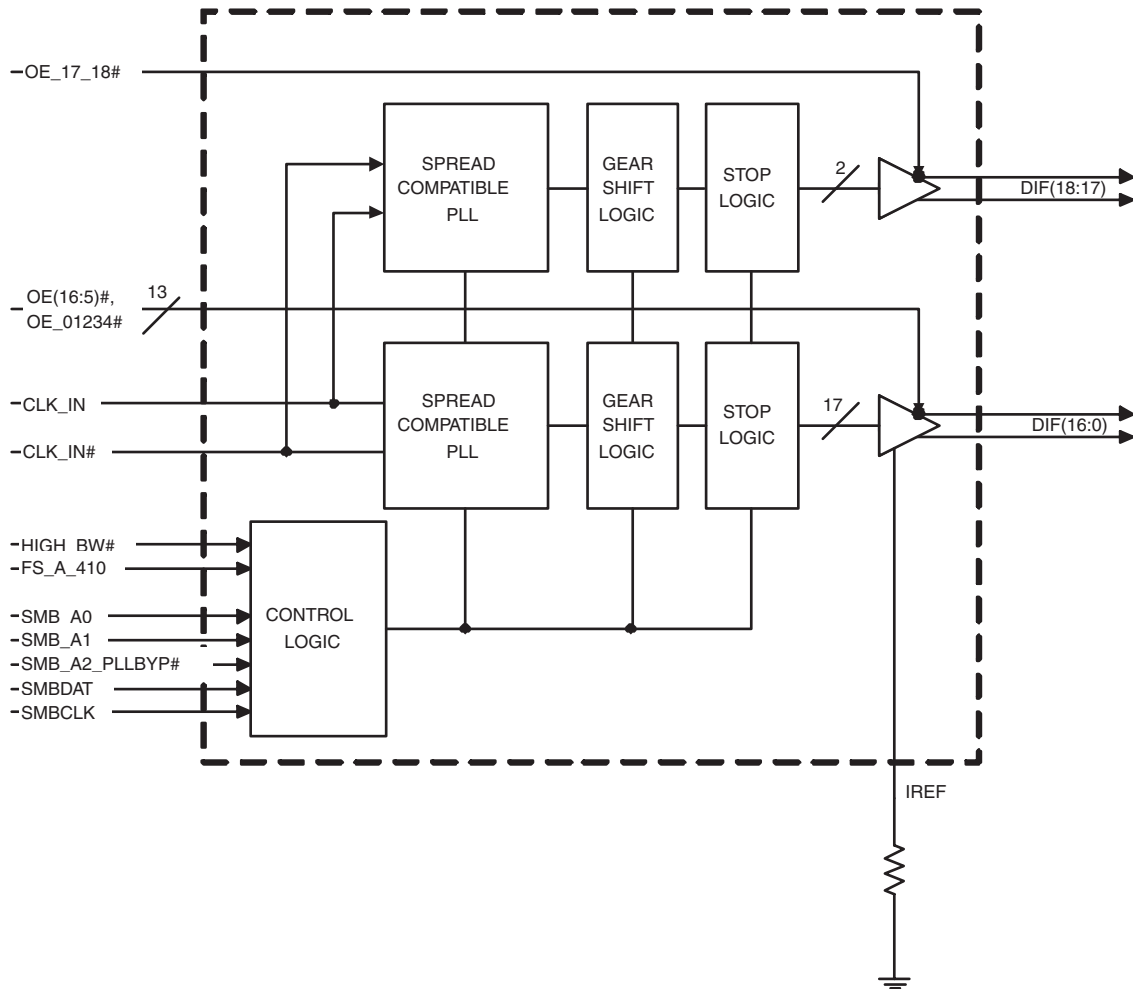

Power Groups

Pin Number		Description
VDD	GND	
3	2	Main PLL, Analog
11,27,47,63	10,28,46,64	DIF clocks

ICS9FG1901 Programmable Gear Ratios

FS_A_410	SMBus Byte 0				Input (m)	Output (n)	Gear Ratio (n/m)	Input (CPU FSB) and Output Frequencies (MHz)				
	Bit 3	Bit 2	Bit 1	Bit 0				200.0	266.7	320.0	333.3	400.0
0	0	0	0	0	3	1	0.333	66.7	88.9	106.7	111.1	133.3
0	0	0	0	1	5	2	0.400	80.0	106.7	128.0	133.3	160.0
0	0	0	1	0	12	5	0.417	83.3	111.1	133.3	138.9	166.7
0	0	0	1	1	2	1	0.500	100.0	133.3	160.0	166.7	200.0
0	0	1	0	0	5	3	0.600	120.0	160.0	192.0	200.0	240.0
0	0	1	0	1	8	5	0.625	125.0	166.7	200.0	208.3	250.0
0	0	1	1	0	3	2	0.667	133.3	177.8	213.3	222.2	266.7
0	0	1	1	1	4	3	0.750	150.0	200.0	240.0	250.0	300.0
0	1	0	0	0	6	5	0.833	166.7	222.2	266.7	277.8	333.3
0	1	0	0	1	1	1	1.000	200.0	266.7	320.0	333.3	400.0
0	1	0	1	0	5	6	1.200	240.0	320.0	384.0	400.0	NA
0	1	0	1	1	4	5	1.250	250.0	333.3	400.0	NA	NA
0	1	1	0	0	3	4	1.333	266.7	355.6	NA	NA	NA
0	1	1	0	1	2	3	1.500	300.0	400.0	NA	NA	NA
0	1	1	1	0	3	5	1.667	333.3	NA	NA	NA	NA
0	1	1	1	1	1	2	2.000	400.0	NA	NA	NA	NA
								CLK IN (CPU FSB) Frequency (MHz)				
								100	133.33	160	166.67	
1	0	0	0	0	3	1	0.333					
1	0	0	0	1	5	2	0.400	NA	53.3	64.0	66.7	
1	0	0	1	0	12	5	0.417	NA	55.6	66.7	69.4	
1	0	0	1	1	2	1	0.500	50.0	66.7	80.0	83.3	
1	0	1	0	0	5	3	0.600	60.0	80.0	96.0	100.0	
1	0	1	0	1	8	5	0.625	62.5	83.3	100.0	104.2	
1	0	1	1	0	3	2	0.667	66.7	88.9	106.7	111.1	
1	0	1	1	1	5	4	0.800	80.0	106.7	128.0	133.3	
1	1	0	0	0	6	5	0.833	NA	111.1	133.3	138.9	
1	1	0	0	1	1	1	1.000	100.0	133.3	160.0	166.7	
1	1	0	1	0	5	6	1.200	120.0	160.0	192.0	200.0	
1	1	0	1	1	4	5	1.250	125.0	166.7	200.0	208.3	
1	1	1	0	0	3	4	1.333	133.3	177.8	213.3	222.2	
1	1	1	0	1	2	3	1.500	150.0	200.0			
1	1	1	1	0	3	5	1.667	166.7	222.2	266.7	277.8	
1	1	1	1	1	1	2	2.000	200.0	266.7	320.0	333.3	

Note: Lines in **BOLD** are Power-up defaults for FS_A_410 = 0 and 1 respectively.

Shaded areas are shown for reference only and are not necessarily valid operating points

Absolute Max

Symbol	Parameter	Min	Max	Units
VDD_A	3.3V Core Supply Voltage		V _{DD} + 0.5V	V
VDD_In	3.3V Logic Input Supply Voltage	GND - 0.5	V _{DD} + 0.5V	V
Ts	Storage Temperature	-65	150	°C
Tambient	Ambient Operating Temp	0	70	°C
Tcase	Case Temperature		115	°C
ESD prot	Input ESD protection human body model	2000		V

Electrical Characteristics - Input/Supply/Common Output Parameters

T_A = 0 - 70°C; Supply Voltage V_{DD} = 3.3 V +/-5%

PARAMETER	SYMBOL	CONDITIONS	MIN	TYP	MAX	UNITS	NOTES
Input High Voltage	V _{IH}	3.3 V +/-5%	2		V _{DD} + 0.3	V	
Input Low Voltage	V _{IL}	3.3 V +/-5%	V _{SS} - 0.3		0.8	V	
Input High Current	I _{IH}	V _{IN} = V _{DD}	-5		5	uA	
Input Low Current	I _{IL1}	V _{IN} = 0 V; Inputs with no pull-up resistors	-5			uA	
	I _{IL2}	V _{IN} = 0 V; Inputs with pull-up resistors	-200			uA	
Low Threshold Input-High Voltage	V _{IH_FS}	3.3 V +/-5%	0.7		V _{DD} + 0.3	V	
Low Threshold Input-Low Voltage	V _{IL_FS}	3.3 V +/-5%	V _{SS} - 0.3		0.35	V	
Operating Current	I _{DD3.3OP}	all outputs driven		450	600	mA	
Powerdown Current	I _{DD3.3PD}	all differential pairs tri-stated		13	36	mA	
Input Frequency	F _i	V _{DD} = 3.3 V	100		400	MHz	3
Pin Inductance	L _{pin}				7	nH	1
Input Capacitance	C _{IN}	Logic Inputs			5	pF	1
	C _{OUT}	Output pin capacitance		2.500		pF	1
Clk Stabilization	T _{STAB}	From V _{DD} Power-Up or valid input clock, whichever comes last		1.300	1.8	ms	1,2
Modulation Frequency Tracking		Triangular Modulation	30		33	kHz	1
SMBus Voltage	V _{MAX}	Maximum input voltage			5.5	V	1
Low-level Output Voltage	V _{OL}	@ I _{PULLUP}			0.4	V	1
Current sinking at V _{OL} = 0.4 V	I _{PULLUP}		4			mA	1
SCLK/SDATA Clock/Data Rise Time	T _{RI2C}	(Max V _{IL} - 0.15) to (Min V _{IH} + 0.15)			1000	ns	1
SCLK/SDATA Clock/Data Fall Time	T _{FI2C}	(Min V _{IH} + 0.15) to (Max V _{IL} - 0.15)			300	ns	1

¹Guaranteed by design and characterization, not 100% tested in production.

²See timing diagrams for timing requirements.

³Output frequency accuracy is dependent upon the accuracy of the input frequency measured at the CLK_IN pins.

Electrical Characteristics - DIF 0.7V Current Mode Differential Pair

T_A = 0 - 70°C; V_{DD} = 3.3 V +/-5%; C_L = 2pF, R_S = 33.2Ω, R_p = 49.9Ω, I_{REF} = 475Ω

PARAMETER	SYMBOL	CONDITIONS	MIN	TYP	MAX	UNITS	NOTES
Current Source Output Impedance	Z _o ¹	V _O = V _x	3000			Ω	1
Voltage High	VHigh	Statistical measurement on single ended signal using oscilloscope math function.	660	750	850	mV	1,3
Voltage Low	VLow		-150		150		1,3
Max Voltage	Vovs	Measurement on single ended signal using absolute value.			1150	mV	1
Min Voltage	Vuds		-300				1
Crossing Voltage (abs)	Vcross(abs)		250		550	mV	1
Crossing Voltage (var)	d-Vcross	Variation of crossing over all edges			140	mV	1
Long Accuracy	ppm	see Tperiod min-max values	-300		300	ppm	1,2
Average period	Tperiod	400MHz nominal	2.4993		2.5008	ns	2
		400MHz spread	2.4993		2.5133	ns	2
		333.33MHz nominal	2.9991		3.0009	ns	2
		333.33MHz spread	2.9991		3.016	ns	2
		266.66MHz nominal	3.7489		3.7511	ns	2
		266.66MHz spread	3.7489		3.77	ns	2
		200MHz nominal	4.9985		5.0015	ns	2
		200MHz spread	4.9985		5.0266	ns	2
		166.66MHz nominal	5.9982		6.0018	ns	2
		166.66MHz spread	5.9982		6.0320	ns	2
		133.33MHz nominal	7.4978		7.5023	ns	2
		133.33MHz spread	7.4978		7.5400	ns	2
		100.00MHz nominal	9.9970		10.0030	ns	2
		100.00MHz spread	9.9970		10.0533	ns	2
Absolute min period	T _{absmin}	400MHz nominal/spread	2.4143			ns	1,2
		333.33MHz nominal/spread	2.9141			ns	1,2
		266.66MHz nominal/spread	3.6639			ns	1,2
		200MHz nominal/spread	4.8735			ns	1,2
		166.66MHz nominal/spread	5.8732			ns	1,2
		133.33MHz nominal/spread	7.3728			ns	1,2
		100.00MHz nominal/spread	9.8720			ns	1,2
Rise Time	t _r	V _{OL} = 0.175V, V _{OH} = 0.525V	175	400	700	ps	1
Fall Time	t _f	V _{OH} = 0.525V V _{OL} = 0.175V	175	425	700	ps	1
Rise Time Variation	d-t _r			20	125	ps	1
Fall Time Variation	d-t _f			15	125	ps	1
Duty Cycle	d _{ts}	Measurement from differential waveform	45	50.5	55	%	1
Output-to-Output Skew - DIF(0:16)	t _{sk3_016}	V _T = 50%, Skew within Group of 17, 1 to 1 mode only		75	100	ps	1
Output-to-Output Skew - DIF(0:18)	t _{sk3_018}	V _T = 50%, Skew across all outputs 1 to 1 mode only		200	225	ps	1
Input-to-Output Delay	t _{pdpll}	PLL Mode	-500		500	ps	1
	t _{pdby}	Bypass Mode	2.5	3.6	4.5	ns	1
Jitter, Cycle to cycle	t _{jyc-cyc}	PLL mode, from differential waveform		40	50	ps	1
		Bypass mode as additive jitter		25	50	ps	1

¹Guaranteed by design and characterization, not 100% tested in production.

²All Long Term Accuracy and Clock Period specifications are guaranteed assuming that the input frequency meets CK410 accuracy requirements

³I_{REF} = V_{DD}/(3xR_R). For R_R = 475Ω (1%), I_{REF} = 2.32mA. I_{OH} = 6 x I_{REF} and V_{OH} = 0.7V @ Z_o = 50Ω

PLL Bandwidth and Peaking

Parameter		Conditions	Min	Typical	Max	Units	Notes
PLL Jitter Peaking	$j_{\text{peak-hibw}}$	(HIGH_BW# = 0)	0	1	2.5	dB	2,8
PLL Jitter Peaking	$j_{\text{peak-lobw}}$	(HIGH_BW# = 1)	0	1	2	dB	2,8
PLL Bandwidth	p_{llHIBW}	(HIGH_BW# = 0)	2	2.3	4	MHz	1,8
PLL Bandwidth	p_{llLOBW}	(HIGH_BW# = 1)	0.7	1.28	1.4	MHz	1,8
Output phase jitter impact – PCIe* Gen1	θ_{PCIe1}	(including PLL BW 1.5-22 MHz, $z = 0.54$, $T_d=10$ ns, $F_{\text{trk}}=1.5$ MHz)	0	77	108	ps	3,6,7,8
Output phase jitter impact – FBD	θ_{FBD}	(including PLL BW 11- 33 Mz, $z = 0.54$, $T_d=5$ ns, $F_{\text{trk}}=0.2$ MHz)	0		3	ps RMS	3,4,7,8

NOTES:

1. Measured at 3 db down or half power point.
2. Measured as maximum pass band gain. At frequencies within the loop BW, highest point of magnification is called PLL jitter peaking.
3. Post processed evaluation through Intel supplied Matlab scripts.
4. Refer to FB-DIMM Specification: "High Speed Differential Point-to-Point Link at 1.5 V" for updates to this specification.
5. PCIe* Gen2 filter characteristics are subject to final ratification by PC ISIG. Please check the PCI* SIG for the latest specification. Tested with DBxx00G driven by low phase noise signal generator such as an Agilent 8133A.
6. These jitter numbers are defined for a BER of 1E-12. Measured numbers at a smaller sample size have to be extrapolated to this BER target.
7. $z = 0.54$ is implying a jitter peaking of 3 dB.
8. Guaranteed by design and characterization, not 100% tested in production.

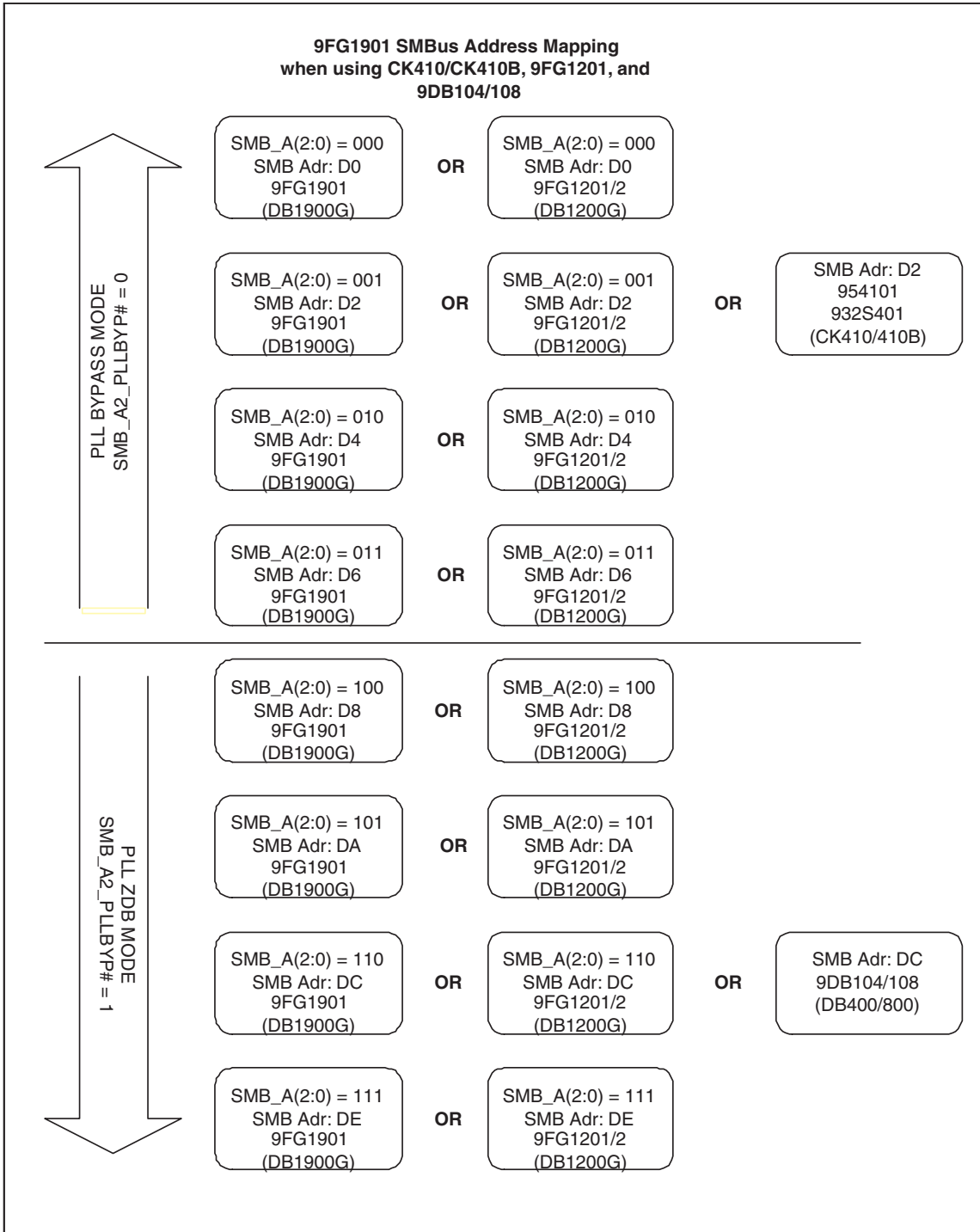

SMBusTable: FSB Frequency Select Register

Byte 0	Pin #	Name	Control Function	Type	0	1	PWD	
Bit 7	DIF(16:0)	GRSEL_17	Group of 17 gear ratio select	RW	Gear Ratio	1:1	1	
Bit 6	DIF(18:17)	GRSEL_2	Group of 2 gear ratio select	RW	Gear Ratio	1:1	1	
Bit 5		Reserved						X
Bit 4	-	FS_A_410 Latched Input		RW	See ICS9FG1901 Programmable Gear Ratios Table		Latch	
Bit 3	-	FSBG_3	FSB Gear Ratio FS_3	RW			x	
Bit 2	-	FSBG_2	FSB Gear Ratio FS_2	RW			0	
Bit 1	-	FSBG_1	FSB Gear Ratio FS_1	RW			x	
Bit 0	-	FSBG_0	FSB Gear Ratio FS_0	RW			1	

SMBusTable: Output Control Register

Byte 1	Pin #	Name	Control Function	Type	0	1	PWD
Bit 7		DIF_7	Output Control	RW	Hi-Z	Enable	1
Bit 6		DIF_6	Output Control	RW	Hi-Z	Enable	1
Bit 5		DIF_5	Output Control	RW	Hi-Z	Enable	1
Bit 4		DIF_4	Output Control	RW	Hi-Z	Enable	1
Bit 3		DIF_3	Output Control	RW	Hi-Z	Enable	1
Bit 2		DIF_2	Output Control	RW	Hi-Z	Enable	1
Bit 1		DIF_1	Output Control	RW	Hi-Z	Enable	1
Bit 0		DIF_0	Output Control	RW	Hi-Z	Enable	1

SMBusTable: Output and PLL BW Control Register

Byte 2	Pin #	Name	Control Function	Type	0	1	PWD
Bit 7	see note	PLL_BW# adjust		RW	High BW	Low BW	1
Bit 6	see note	BYPASS# test mode / PLL		RW	Bypass	PLL	1
Bit 5		DIF_13	Output Control	RW	Hi-Z	Enable	1
Bit 4		DIF_12	Output Control	RW	Hi-Z	Enable	1
Bit 3		DIF_11	Output Control	RW	Hi-Z	Enable	1
Bit 2		DIF_10	Output Control	RW	Hi-Z	Enable	1
Bit 1		DIF_9	Output Control	RW	Hi-Z	Enable	1
Bit 0		DIF_8	Output Control	RW	Hi-Z	Enable	1

Note: Bit 7 is wired OR to the HIGH_BW# input, any 0 selects High BW

Note: Bit 6 is wired OR to the SMB_A2_PLLBYP# input, any 0 selects Fanout Bypass mode

SMBusTable: Output Enable Readback Register

Byte 3	Pin #	Name	Control Function	Type	0	1	PWD
Bit 7		Readback - OE9# Input		R	Readback		X
Bit 6		Readback - OE8# Input		R	Readback		X
Bit 5		Readback - OE7# Input		R	Readback		X
Bit 4		Readback - OE6# Input		R	Readback		X
Bit 3		Readback - OE5# Input		R	Readback		X
Bit 2		Readback - OE_01234# Input		R	Readback		X
Bit 1	8	Readback - HIGH_BW# In		R	Readback		X
Bit 0	72	Readback - SMB_A2_PLLBYP# In		R	Readback		X

SMBusTable: Output Enable Readback Register

Byte 4	Pin #	Name	Control Function	Type	0	1	PWD
Bit 7	69		Readback - OE17_18# Input	R	Readback		X
Bit 6	60		Readback - OE16# Input	R	Readback		X
Bit 5	57		Readback - OE15# Input	R	Readback		X
Bit 4	54		Readback - OE14# Input	R	Readback		X
Bit 3	51		Readback - OE13# Input	R	Readback		X
Bit 2	48		Readback - OE12# Input	R	Readback		X
Bit 1	43		Readback - OE11# Input	R	Readback		X
Bit 0	40		Readback - OE10# Input	R	Readback		X

SMBusTable: Vendor & Revision ID Register

Byte 5	Pin #	Name	Control Function	Type	0	1	PWD
Bit 7	-	RID3	REVISION ID	R	-	-	X
Bit 6	-	RID2		R	-	-	X
Bit 5	-	RID1		R	-	-	X
Bit 4	-	RID0		R	-	-	X
Bit 3	-	VID3	VENDOR ID	R	-	-	0
Bit 2	-	VID2		R	-	-	0
Bit 1	-	VID1		R	-	-	0
Bit 0	-	VID0		R	-	-	1

SMBusTable: DEVICE ID

Byte 6	Pin #	Name	Control Function	Type	0	1	PWD
Bit 7	-		Device ID 7 (MSB)	RW	Reserved		1
Bit 6	-		Device ID 6	RW	Reserved		0
Bit 5	-		Device ID 5	RW	Reserved		0
Bit 4	-		Device ID 4	RW	Reserved		1
Bit 3	-		Device ID 3	RW	Reserved		0
Bit 2	-		Device ID 2	RW	Reserved		0
Bit 1	-		Device ID 1	RW	Reserved		0
Bit 0	-		Device ID 0	RW	Reserved		1

SMBusTable: Byte Count Register

Byte 7	Pin #	Name	Control Function	Type	0	1	PWD
Bit 7	-	BC7	Writing to this register configures how many bytes will be read back.	RW	-	-	0
Bit 6	-	BC6		RW	-	-	0
Bit 5	-	BC5		RW	-	-	0
Bit 4	-	BC4		RW	-	-	0
Bit 3	-	BC3		RW	-	-	0
Bit 2	-	BC2		RW	-	-	1
Bit 1	-	BC1		RW	-	-	1
Bit 0	-	BC0		RW	-	-	1

SMBusTable: Control Pin Readback Register

Byte 8	Pin #	Name	Control Function	Type	0	1	PWD
Bit 7	5		Readback - FS_A_410	R	Readback		X
Bit 6			RESERVED				X
Bit 5			RESERVED				X
Bit 4		DIF_18	Output Control	RW	Hi-Z	Enable	1
Bit 3		DIF_17	Output Control	RW	Hi-Z	Enable	1
Bit 2		DIF_16	Output Control	RW	Hi-Z	Enable	1
Bit 1		DIF_15	Output Control	RW	Hi-Z	Enable	1
Bit 0		DIF_14	Output Control	RW	Hi-Z	Enable	1

SMBusTable: Reserved Register

Byte 9	Pin #	Name	Control Function	Type	0	1	PWD
Bit 7			RESERVED				0
Bit 6			RESERVED				0
Bit 5			RESERVED				0
Bit 4			RESERVED				0
Bit 3			RESERVED				0
Bit 2			RESERVED				0
Bit 1			RESERVED				0
Bit 0			RESERVED				0

SMBus Table: M/N Programming & Watchdog Safe Register

Byte 10	Pin #	Name	Control Function	Type	0	1	PWD
Bit 7	-	M/N_EN	Gearing PLL and 1:1 PLL M/N Programming Enable	RW	Disable	Enable	0
Bit 6			RESERVED				X
Bit 5			RESERVED				X
Bit 4			RESERVED				X
Bit 3			RESERVED				X
Bit 2			RESERVED				X
Bit 1			RESERVED				X
Bit 0			RESERVED				X

SMBus Table: Gearing PLL Frequency Control Register

Byte 11	Pin #	Name	Control Function	Type	0	1	PWD
Bit 7	-	Gearing PLL N Div8	N Divider Prog bit 8	RW			X
Bit 6	-	Gearing PLL N Div9	N Divider Prog bit 9	RW			X
Bit 5	-	Gearing PLL M Div5	M Divider Programming bit (5:0)	RW			X
Bit 4	-	Gearing PLL M Div4		RW			X
Bit 3	-	Gearing PLL M Div3		RW			X
Bit 2	-	Gearing PLL M Div2		RW			X
Bit 1	-	Gearing PLL M Div1		RW			X
Bit 0	-	Gearing PLL M Div0		RW			X

SMBus Table: Gearing PLL Frequency Control Register

Byte 12	Pin #	Name	Control Function	Type	0	1	PWD
Bit 7	-	Gearing PLL N Div7	N Divider Programming Byte12 bit(7:0) and Byte11 bit(7:6)	RW			X
Bit 6	-	Gearing PLL N Div6		RW			X
Bit 5	-	Gearing PLL N Div5		RW			X
Bit 4	-	Gearing PLL N Div4		RW			X
Bit 3	-	Gearing PLL N Div3		RW			X
Bit 2	-	Gearing PLL N Div2		RW			X
Bit 1	-	Gearing PLL N Div1		RW			X
Bit 0	-	Gearing PLL N Div0		RW			X

SMBusTable: Gearing PLL Output Divider Register (Rev H and higher)

Byte 13	Pin #	Name	Control Function	Type	0	1	PWD
Bit 7			RESERVED				0
Bit 6			RESERVED				0
Bit 5			RESERVED				0
Bit 4			RESERVED				0
Bit 3		Gearing PLL OutDiv 3	PLL 1 Output Divider	RW	See Output Divider Table		X
Bit 2		Gearing PLL OutDiv 2	PLL 1 Output Divider	RW			X
Bit 1		Gearing PLL OutDiv 1	PLL 1 Output Divider	RW			X
Bit 0		Gearing PLL OutDiv 0	PLL 1 Output Divider	RW			X

SMBusTable: Reserved Register

Byte 14	Pin #	Name	Control Function	Type	0	1	PWD
Bit 7			RESERVED				0
Bit 6			RESERVED				0
Bit 5			RESERVED				0
Bit 4			RESERVED				0
Bit 3			RESERVED				0
Bit 2			RESERVED				0
Bit 1			RESERVED				0
Bit 0			RESERVED				0

SMBusTable: Reserved Register

Byte 15	Pin #	Name	Control Function	Type	0	1	PWD
Bit 7			RESERVED				0
Bit 6			RESERVED				0
Bit 5			RESERVED				0
Bit 4			RESERVED				0
Bit 3			RESERVED				0
Bit 2			RESERVED				0
Bit 1			RESERVED				0
Bit 0			RESERVED				0

SMBusTable: Reserved Register

Byte 16	Pin #	Name	Control Function	Type	0	1	PWD
Bit 7				RESERVED			0
Bit 6				RESERVED			0
Bit 5				RESERVED			0
Bit 4				RESERVED			0
Bit 3				RESERVED			0
Bit 2				RESERVED			0
Bit 1				RESERVED			0
Bit 0				RESERVED			0

SMBus Table: 1:1 PLL Frequency Control Register

Byte 17	Pin #	Name	Control Function	Type	0	1	PWD
Bit 7	-	1:1 PLL N Div8	N Divider Prog bit 8	RW			X
Bit 6	-	1:1 PLL N Div9	N Divider Prog bit 9	RW			X
Bit 5	-	1:1 PLL M Div5	M Divider Programming bits	RW			X
Bit 4	-	1:1 PLL M Div4		RW			X
Bit 3	-	1:1 PLL M Div3		RW			X
Bit 2	-	1:1 PLL M Div2		RW			X
Bit 1	-	1:1 PLL M Div1		RW			X
Bit 0	-	1:1 PLL M Div0		RW			X

SMBus Table: 1:1 PLL Frequency Control Register

Byte 18	Pin #	Name	Control Function	Type	0	1	PWD
Bit 7	-	1:1 PLL N Div7	N Divider Programming b(7:0)	RW			X
Bit 6	-	1:1 PLL N Div6		RW			X
Bit 5	-	1:1 PLL N Div5		RW			X
Bit 4	-	1:1 PLL N Div4		RW			X
Bit 3	-	1:1 PLL N Div3		RW			X
Bit 2	-	1:1 PLL N Div2		RW			X
Bit 1	-	1:1 PLL N Div1		RW			X
Bit 0	-	1:1 PLL N Div0		RW			X

SMBusTable: 1:1 PLL Output Divider Register (Rev H and higher)

Byte 19	Pin #	Name	Control Function	Type	0	1	PWD
Bit 7				RESERVED			0
Bit 6				RESERVED			0
Bit 5				RESERVED			0
Bit 4				RESERVED			0
Bit 3		1:1 PLL OutDiv 3	PLL 2 Output Divider	RW	See Output Divider Table		X
Bit 2		1:1 PLL OutDiv 2	PLL 2 Output Divider	RW			X
Bit 1		1:1 PLL OutDiv 1	PLL 2 Output Divider	RW			X
Bit 0		1:1 PLL OutDiv 0	PLL 2 Output Divider	RW			X

SMBusTable: Reserved Register

Byte 20	Pin #	Name	Control Function	Type	0	1	PWD
Bit 7			RESERVED				0
Bit 6			RESERVED				0
Bit 5			RESERVED				0
Bit 4			RESERVED				0
Bit 3			RESERVED				0
Bit 2			RESERVED				0
Bit 1			RESERVED				0
Bit 0			RESERVED				0

SMBusTable: Test Byte Register

Byte 21	Test	Test Function	Type	Test Result	PWD
Bit 7		ICS ONLY TEST	RW	Reserved	0
Bit 6		ICS ONLY TEST	RW	Reserved	0
Bit 5		ICS ONLY TEST	RW	Reserved	0
Bit 4		ICS ONLY TEST	RW	Reserved	0
Bit 3		ICS ONLY TEST	RW	Reserved	0
Bit 2		ICS ONLY TEST	RW	Reserved	0
Bit 1		ICS ONLY TEST	RW	Reserved	0
Bit 0		ICS ONLY TEST	RW	Reserved	0

Note: Do NOT write to Bit 21. Erratic device operation will result!

**Output Divider Table Rev
H Devices only**

Byte 13(3:0) Byte 19(3:0)	Divider Value
0000	2
0001	3
0010	5
0011	NA
0100	4
0101	6
0110	10
0111	NA
1000	8
1001	12
1010	20
1011	NA
1100	NA
1101	nA
1110	NA
1111	NA

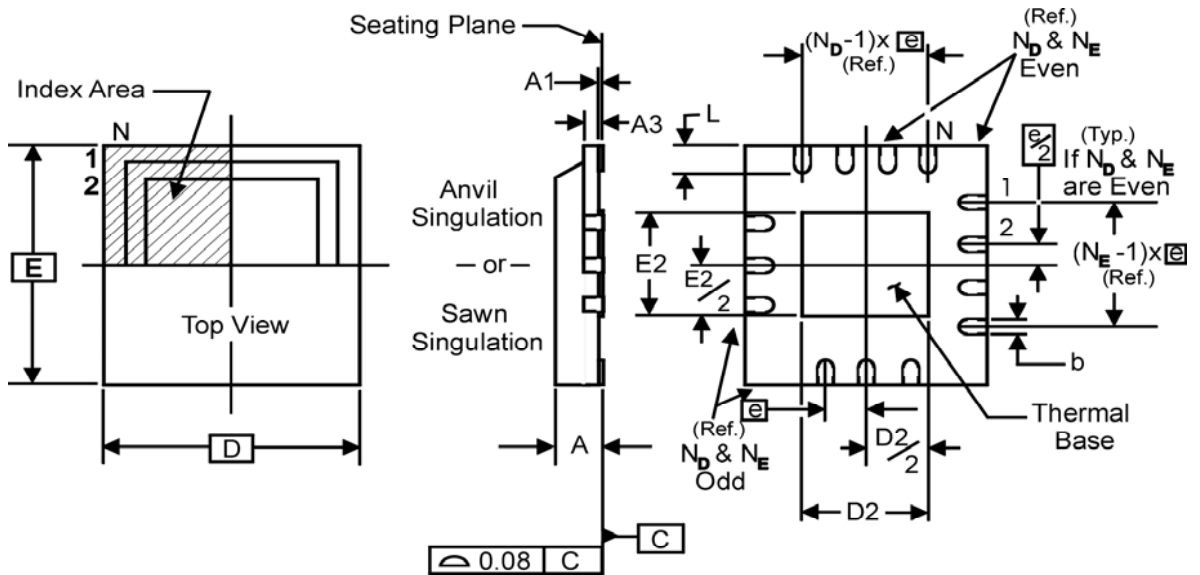

THERMALLY ENHANCED, VERY THIN, FINE PITCH
QUAD FLAT / NO LEAD PLASTIC PACKAGE

DIMENSIONS		
SYMBOL	MIN.	MAX.
A	0.8	1.0
A1	0	0.05
A3	0.25 Reference	
b	0.18	0.3
e	0.50 BASIC	

DIMENSIONS	
SYMBOL	ICS 72L TOLERANCE
N	72
N_D	18
N_E	18
D x E BASIC	10.00 x 10.00
D2 MIN. / MAX.	5.75 / 6.15
E2 MIN. / MAX.	5.75 / 6.15
L MIN. / MAX.	0.3 / 0.5

Ordering Information

ICS9FG1901yKLF-T

Reference: JEDEC Publication 95, MO-220

Example:

ICS XXXX y K - LFT



Revision History

Rev.	Issue Date	Description	Page #
A	4/25/2005	1. Added Symbol "A" to Dimensions table. 2. Preliminary Release.	15
B	12/19/2005	1. Rearranged page 1 to enlarge Pin Configuration	1
C	6/14/2006	1. Updated TBD to actual values. 2. Added PLL BW and Peaking Table. 3. Updated Skew specs. 4. Updated Paddle Dimensions.	Various
D	8/17/2006	Final Release.	-
E	1/2/2007	1. Added Output Dividers to Bytes 13 and 19 for Rev H devices. 2. Changed PLL1 and PLL2 naming to 1:1 and Gearing PLL	Various

IMPORTANT NOTICE AND DISCLAIMER

RENESAS ELECTRONICS CORPORATION AND ITS SUBSIDIARIES (“RENESAS”) PROVIDES TECHNICAL SPECIFICATIONS AND RELIABILITY DATA (INCLUDING DATASHEETS), DESIGN RESOURCES (INCLUDING REFERENCE DESIGNS), APPLICATION OR OTHER DESIGN ADVICE, WEB TOOLS, SAFETY INFORMATION, AND OTHER RESOURCES “AS IS” AND WITH ALL FAULTS, AND DISCLAIMS ALL WARRANTIES, EXPRESS OR IMPLIED, INCLUDING, WITHOUT LIMITATION, ANY IMPLIED WARRANTIES OF MERCHANTABILITY, FITNESS FOR A PARTICULAR PURPOSE, OR NON-INFRINGEMENT OF THIRD-PARTY INTELLECTUAL PROPERTY RIGHTS.

These resources are intended for developers who are designing with Renesas products. You are solely responsible for (1) selecting the appropriate products for your application, (2) designing, validating, and testing your application, and (3) ensuring your application meets applicable standards, and any other safety, security, or other requirements. These resources are subject to change without notice. Renesas grants you permission to use these resources only to develop an application that uses Renesas products. Other reproduction or use of these resources is strictly prohibited. No license is granted to any other Renesas intellectual property or to any third-party intellectual property. Renesas disclaims responsibility for, and you will fully indemnify Renesas and its representatives against, any claims, damages, costs, losses, or liabilities arising from your use of these resources. Renesas' products are provided only subject to Renesas' Terms and Conditions of Sale or other applicable terms agreed to in writing. No use of any Renesas resources expands or otherwise alters any applicable warranties or warranty disclaimers for these products.

(Disclaimer Rev.1.01 Jan 2024)

Corporate Headquarters

TOYOSU FORESIA, 3-2-24 Toyosu,
Koto-ku, Tokyo 135-0061, Japan
www.renesas.com

Trademarks

Renesas and the Renesas logo are trademarks of Renesas Electronics Corporation. All trademarks and registered trademarks are the property of their respective owners.

Contact Information

For further information on a product, technology, the most up-to-date version of a document, or your nearest sales office, please visit www.renesas.com/contact-us/.