

56-PIN CK505 W/FULLY INTEGRATED VOLTAGE REGULATOR

ICS9LPR502

Recommended Application:

CK505 compliant clock with fully integrated voltage regulator, PCIe Gen 1 compliant

Output Features:

- 2 - CPU differential low power push-pull pairs
- 7 - SRC differential low power push-pull pairs
- 1 - CPU/SRC selectable differential low power push-pull pair
- 1 - SRC/DOT selectable differential low power push-pull pair
- 5 - PCI, 33MHz
- 1 - PCI_F, 33MHz free running
- 1 - USB, 48MHz
- 1 - REF, 14.318MHz

Key Specifications:

- CPU outputs cycle-cycle jitter < 85ps
- SRC output cycle-cycle jitter < 125ps
- PCI outputs cycle-cycle jitter < 250ps
- +/- 100ppm frequency accuracy on CPU & SRC clocks

Features/Benefits:

- Does not require external pass transistor for voltage regulator
- Supports spread spectrum modulation, default is 0.5% down spread
- Uses external 14.318MHz crystal, external crystal load caps are required for frequency tuning
- One differential push-pull pair selectable between SRC and two single-ended outputs

Table 1: CPU Frequency Select Table

FS _L C ² B0b7	FS _L B ¹ B0b6	FS _L A ¹ B0b5	CPU MHz	SRC MHz	PCI MHz	REF MHz	USB MHz	DOT MHz
0	0	0	266.66	100.00	33.33	14.318	48.00	96.00
0	0	1	133.33					
0	1	0	200.00					
0	1	1	166.66					
1	0	0	333.33					
1	0	1	100.00					
1	1	0	400.00					
1	1	1	Reserved					

1. FS_LA and FS_LB are low-threshold inputs. Please see V_{IL,FS} and V_{IH,FS} specifications in the Input/Supply/Common Output Parameters Table for correct values. Also refer to the Test Clarification Table.
2. FS_LC is a three-level input. Please see the V_{IL,FS} and V_{IH,FS} specifications in the Input/Supply/Common Output Parameters Table for correct values.

Pin Configuration

PCI0/CR#_A	1	56	SCLK
VDDPCI	2	55	SDATA
PCI1/CR#_B	3	54	REF0/FSLC/TEST_SEL
PCI2/TME	4	53	VDDREF
PCI3	5	52	X1
PCI4/SRC5_EN	6	51	X2
PCI_F5/ITP_EN	7	50	GNDREF
GNDPCI	8	49	FSLB/TEST_MODE
VDD48	9	48	CK_PWRGD/PD#
USB_48MHz/FSLA	10	47	VDDCPU
GND48	11	46	CPUT0
VDDI/O96Mhz	12	45	CPUC0
DOTT_96/SRCT0	13	44	GNDCPU
DOTC_96/SRCC0	14	43	CPUT1
GND	15	42	CPUC1
VDD	16	41	VDDI/OCPU
SRCT1/SE1	17	40	NC
SRCC1/SE2	18	39	CPUT2_ITP/SRCT8
GND	19	38	CPUC2_ITP/SRCC8
VDDPLL3I/O	20	37	VDDSRCI/O
SRCT2/SATAT	21	36	SRCT7/CR#_F
SRCC2/SATAC	22	35	SRCC7/CR#_E
GNDSRC	23	34	GNDSRC
SRCT3/CR#_C	24	33	SRCT6
SRCC3/CR#_D	25	32	SRCC6
VDDSRCI/O	26	31	VDDSRC
SRCT4	27	30	PCI_STOP#/SRCT5
SRCC4	28	29	CPU_STOP#/SRCC5

ICS 9LPR502

56-SSOP/TSSOP

SSOP/TSSOP Pin Description

PIN #	PIN NAME	TYPE	DESCRIPTION
1	PCI0/CR#_A	I/O	3.3V PCI clock output or Clock Request control A for either SRC0 or SRC2 pair The power-up default is PCI0 output, but this pin may also be used as a Clock Request control of SRC pair 0 or SRC pair 2 via SMBus. Before configuring this pin as a Clock Request Pin, the PCI output must first be disabled in byte 2, bit 0 of SMBus address space. After the PCI output is disabled (high-Z), the pin can then be set to serve as a Clock Request pin for either SRC pair 2 or pair 0 using the CR#_A_EN bit located in byte 5 of SMBUs address space. Byte 5, bit 7 0 = PCI0 enabled (default) 1 = CR#_A enabled. Byte 5, bit 6 controls whether CR#_A controls SRC0 or SRC2 pair Byte 5, bit 6 0 = CR#_A controls SRC0 pair (default), 1 = CR#_A controls SRC2 pair
2	VDDPCI	PWR	Power supply pin for the PCI outputs, 3.3V nominal
3	PCI1/CR#_B	I/O	3.3V PCI clock output/Clock Request control B for either SRC1 or SRC4 pair The power-up default is PCI1 output, but this pin may also be used as a Clock Request control of SRC pair 1 or SRC pair 4 via SMBus. Before configuring this pin as a Clock Request Pin, the PCI output must first be disabled in byte 2, bit 1 of SMBus address space. After the PCI output is disabled (high-Z), the pin can then be set to serve as a Clock Request pin for either SRC pair 1 or pair 4 using the CR#_B_EN bit located in byte 5 of SMBUs address space. Byte 5, bit 5 0 = PCI1 enabled (default) 1 = CR#_B enabled. Byte 5, bit 6 controls whether CR#_B controls SRC1 or SRC4 pair Byte 5, bit 4 0 = CR#_B controls SRC1 pair (default) 1 = CR#_B controls SRC4 pair
4	PCI2/TME	I/O	3.3V PCI clock output / Trusted Mode Enable (TME) Latched Input. This pin is sampled on power-up as follows 0 = Overclocking of CPU and SRC Allowed 1 = Overclocking of CPU and SRC <u>NOT</u> allowed After being sampled on power-up, this pin becomes a 3.3V PCI Output
5	PCI3	OUT	3.3V PCI clock output.
6	PCI4/SRC5_EN	I/O	3.3V PCI clock output / SRC5 pair or PCI_STOP#/CPU_STOP# enable strap. On powerup, the logic value on this pin determines if the SRC5 pair is enabled or if CPU_STOP#/PCI_STOP# is enabled (pins 29 and 30). The latched value controls the pin function on pins 29 and 30 as follows 0 = PCI_STOP#/CPU_STOP# 1 = SRC5/SRC5#
7	PCI_F5/ITP_EN	I/O	Free running PCI clock output and ITP/SRC8 enable strap. This output is not affected by the state of the PCI_STOP# pin. On powerup, the state of this pin determines whether pins 38 and 39 are an ITP or SRC pair. 0 = SRC8/SRC8# 1 = ITP/ITP#
8	GNDPCI	PWR	Ground for PCI clocks.
9	VDD48	PWR	Power supply for USB clock, nominal 3.3V.
10	USB_48MHz/FSLA	I/O	Fixed 48MHz USB clock output. 3.3V/ 3.3V tolerant input for CPU frequency selection. Refer to input electrical characteristics for V _{IL_FS} and V _{IH_FS} values.
11	GND48	PWR	Ground pin for the 48MHz outputs.
12	VDD96_IO	PWR	Power supply for DOT96 output. 1.05 to 3.3V +/-5%.
13	DOTT_96/SRCT0	OUT	True clock of SRC or DOT96. The power-up default function is SRC0. After powerup, this pin function may be changed to DOT96 via SMBus Byte 1, bit 7 as follows: 0 = SRC0 1 = DOT96
14	DOTC_96/SRCC0	OUT	Complement clock of SRC or DOT96. The power-up default function is SRC0#. After powerup, this pin function may be changed to DOT96# via SMBus Byte 1, bit 7 as follows 0 = SRC0# 1 = DOT96#
15	GND	PWR	Ground pin for the DOT96 clocks.
16	VDD	PWR	Power supply for SRC / SE1 and SE2 clocks, 3.3V nominal.

SSOP/TSSOP Pin Description (continued)

PIN #	PIN NAME	TYPE	DESCRIPTION
17	SRCT1/SE1	OUT	True clock of differential SRC1 clock pair / 3.3V single-ended output. The powerup default is 100 MHz SRC, -0.5% downspread. The pin function may be changed via SMBus B1b[4:1]
18	SRCC1/SE2	OUT	Complement clock of differential SRC1 clock pair / 3.3V single-ended output. The powerup default is 100 MHz SRC, -0.5% downspread. The pin function may be changed via SMBus B1b[4:1]
19	GND	PWR	Ground pin for SRC / SE1 and SE2 clocks, PLL3.
20	VDDPLL3_IO	PWR	Power supply for PLL3 output. 1.05 to 3.3V +/-5%.
21	SRCT2/SATAT	OUT	True clock of differential SRC/SATA clock pair.
22	SRCC2/SATAC	OUT	Complement clock of differential SRC/SATA clock pair.
23	GNDSRC	PWR	Ground pin for SRC clocks.
24	SRCT3/CR#_C	I/O	<p>True clock of differential SRC clock pair/ Clock Request control C for either SRC0 or SRC2 pair The power-up default is SRCCLK3 output, but this pin may also be used as a Clock Request control of SRC pair 0 or SRC pair 2 via SMBus. Before configuring this pin as a Clock Request Pin, the SRC3 output must first be disabled in byte 4, bit 7 of SMBus address space . After the SRC3 output is disabled, the pin can then be set to serve as a Clock Request pin for either SRC pair 2 or pair 0 using the CR#_C_EN bit located in byte 5 of SMBUs address space.</p> <p>Byte 5, bit 3 0 = SRC3 enabled (default) 1= CR#_C enabled. Byte 5, bit 2 controls whether CR#_C controls SRC0 or SRC2 pair</p> <p>Byte 5, bit 2 0 = CR#_C controls SRC0 pair (default), 1= CR#_C controls SRC2 pair</p>
25	SRCC3/CR#_D	I/O	<p>Complementary clock of differential SRC clock pair/ Clock Request control D for either SRC1 or SRC4 pair The power-up default is SRCCLK3 output, but this pin may also be used as a Clock Request control of SRC pair 1 or SRC pair 4 via SMBus. Before configuring this pin as a Clock Request Pin, the SRC3 output must first be disabled in byte 4, bit 7 of SMBus address space . After the SRC3 output is disabled, the pin can then be set to serve as a Clock Request pin for either SRC pair 1 or pair 4 using the CR#_D_EN bit located in byte 5 of SMBUs address space.</p> <p>Byte 5, bit 1 0 = SRC3 enabled (default) 1= CR#_D enabled. Byte 5, bit 0 controls whether CR#_D controls SRC1 or SRC4 pair</p> <p>Byte 5, bit 0 0 = CR#_D controls SRC1 pair (default), 1= CR#_D controls SRC4 pair</p>
26	VDDSRC_IO	PWR	Power supply for SRC clocks. 1.05 to 3.3V +/-5%.
27	SRCT4	I/O	True clock of differential SRC clock pair 4
28	SRCC4	I/O	Complement clock of differential SRC clock pair 4

SSOP/TSSOP Pin Description (Continued)

PIN #	PIN NAME	TYPE	DESCRIPTION
29	CPU_STOP#/SRCC5	I/O	Stops all CPU Clocks, except those set to be free running clocks / Complement clock of differential SRC pair. The function of this pin is set up by the power-up strap on pin 6, PCI4/SRC5_EN. The logic value sampled on pin 6 at power-up sets the function as follows: 0= CPU_STOP# 1 = SRC5 In AMT mode 3 bits are shifted in from the ICH to set the FSC, FSB, FSA values
30	PCI_STOP#/SRCT5	I/O	Stops all PCI Clocks, except those set to be free running clocks / Complement clock of differential SRC pair. The function of this pin is set up by the power-up strap on pin 6, PCI4/SRC5_EN. The logic value sampled on pin 6 at power-up sets the function as follows: 0= PCI_STOP# 1 = SRC5# In AMT mode, this pin is a clock input which times the FSC, FSB, FSA bits shifted in on pin 37.
31	VDDSRC	PWR	VDD pin for SRC Pre-drivers, 3.3V nominal
32	SRCC6	OUT	Complement clock of low power differential SRC clock pair.
33	SRCT6	OUT	True clock of low power differential SRC clock pair.
34	GNDSRC	PWR	Ground for SRC clocks
35	SRCC7/CR#_E	I/O	SRC7 complement or Clock Request control E for SRC6 pair The power-up default is SRC7#, but this pin may also be used as a Clock Request control of SRC6 via SMBus. Before configuring this pin as a Clock Request Pin, the SRC7 output pair must first be disabled in byte 3, bit 3 of SMBus configuration space. After the SRC output is disabled (high-Z), the pin can then be set to serve as a Clock Request for SRC6 pair using byte 6, bit 7 of SMBus configuration space Byte 6, bit 7 0 = SRC7# enabled (default) 1= CR#_E controls SRC6.
36	SRCT7/CR#_F	I/O	SRC7 true or Clock Request control 8 for SRC8 pair The power-up default is SRC7, but this pin may also be used as a Clock Request control of SRC8 via SMBus. Before configuring this pin as a Clock Request Pin, the SRC7 output pair must first be disabled in byte 3, bit 3 of SMBus configuration space. After the SRC output is disabled (high-Z), the pin can then be set to serve as a Clock Request for SRC8 pair using byte 6, bit 6 of SMBus configuration space Byte 6, bit 6 0 = SRC7# enabled (default) 1 = CR#_F controls SRC8.
37	VDDSRC_IO	PWR	Power supply for SRC outputs. 1.05 to 3.3V +/-5%.
38	CPUC2_ITP/SRCC8	OUT	Complement clock of low power differential CPU2/Complement clock of differential SRC pair. The function of this pin is determined by the latched input value on pin 7, PCIF5/ITP_EN on powerup. The function is as follows: Pin 7 latched input Value 0 = SRC8# 1 = ITP#
39	CPUT2_ITP/SRCT8	OUT	True clock of low power differential CPU2/True clock of differential SRC pair. The function of this pin is determined by the latched input value on pin 7, PCIF5/ITP_EN on powerup. The function is as follows: Pin 7 latched input Value 0 = SRC8 1 = ITP
40	NC	N/A	No Connect
41	VDDCPU_IO	PWR	Supply for CPU outputs. 1.05 to 3.3V +/-5%.
42	CPUC1_F	OUT	Complement clock of low power differential CPU clock pair. This clock will be free-running during iAMT.
43	CPUT1_F	OUT	True clock of low power differential CPU clock pair. This clock will be free-running during iAMT.
44	GNDCPU	PWR	Ground Pin for CPU Outputs
45	CPUC0	OUT	Complement clock of low power differential CPU clock pair.
46	CPUT0	OUT	True clock of low power differential CPU clock pair.
47	VDDCPU	PWR	Power Supply 3.3V nominal.

SSOP/TSSOP Pin Description (Continued)

PIN #	PIN NAME	TYPE	DESCRIPTION
48	CK_PWRGD/PD#	IN	Notifies CK505 to sample latched inputs, or iAMT entry/exit, or PWRDWN# mode
49	FSLB/TEST_MODE	IN	3.3V tolerant input for CPU frequency selection. Refer to input electrical characteristics for V_{iL_FS} and V_{iH_FS} values. TEST_MODE is a real time input to select between Hi-Z and REF/N divider mode while in test mode. Refer to Test Clarification Table.
50	GNDREF	PWR	Ground pin for crystal oscillator circuit
51	X2	OUT	Crystal output, nominally 14.318MHz.
52	X1	IN	Crystal input, Nominally 14.318MHz.
53	VDDREF	PWR	Power pin for the REF outputs, 3.3V nominal.
54	REF0/FSLC/TEST_SEL	I/O	3.3V 14.318MHz reference clock/3.3V tolerant low threshold input for CPU frequency selection. Refer to input electrical characteristics for V_{iL_FS} and V_{iH_FS} values/ TEST_SEL: 3-level latched input to enable test mode. Refer to Test Clarification Table.
55	SDATA	I/O	Data pin for SMBus circuitry, 5V tolerant.
56	SCLK	IN	Clock pin of SMBus circuitry, 5V tolerant.

Fully Integrated Regulator Connection for Desktop/Mobile Applications

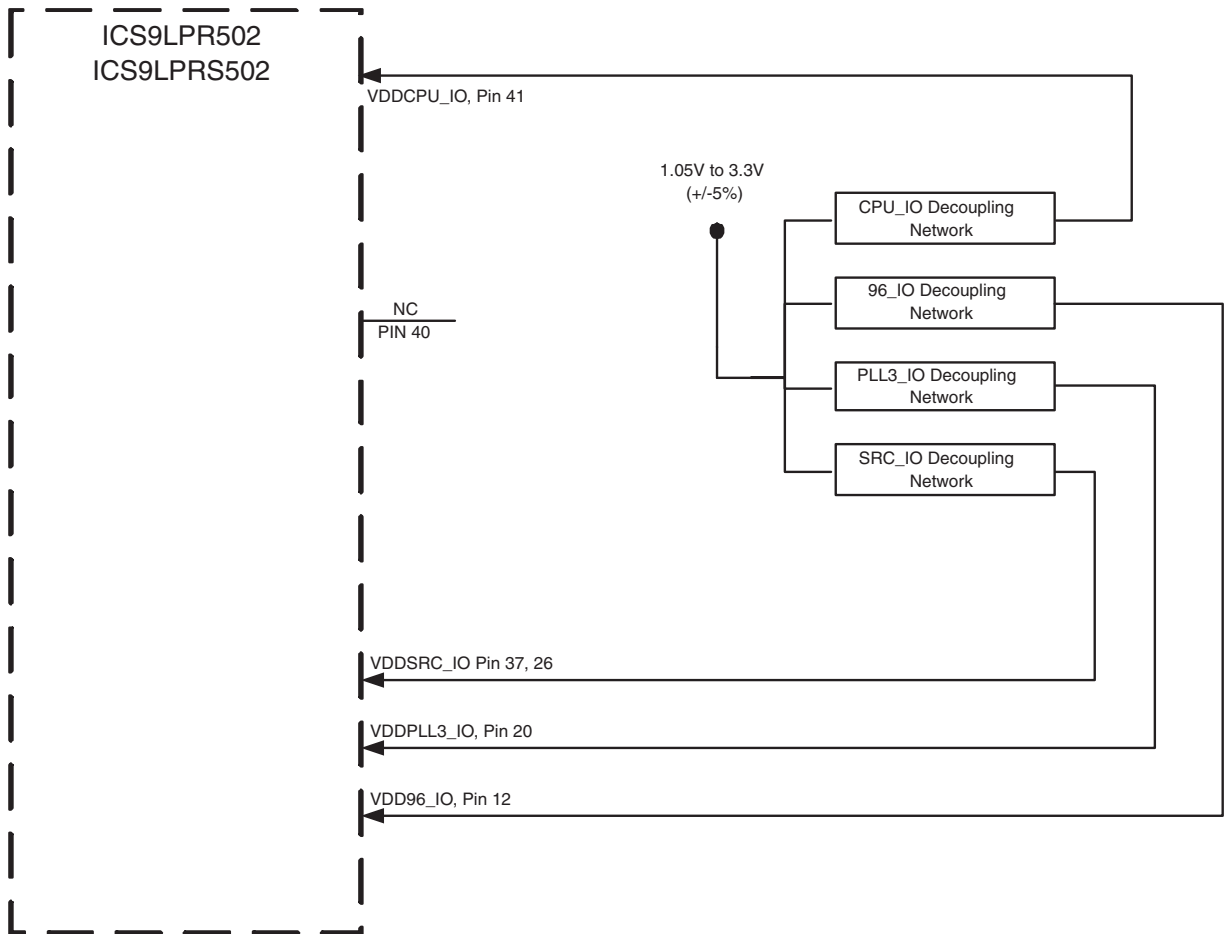

SSOP/TSSOP Pin Description (Continued)

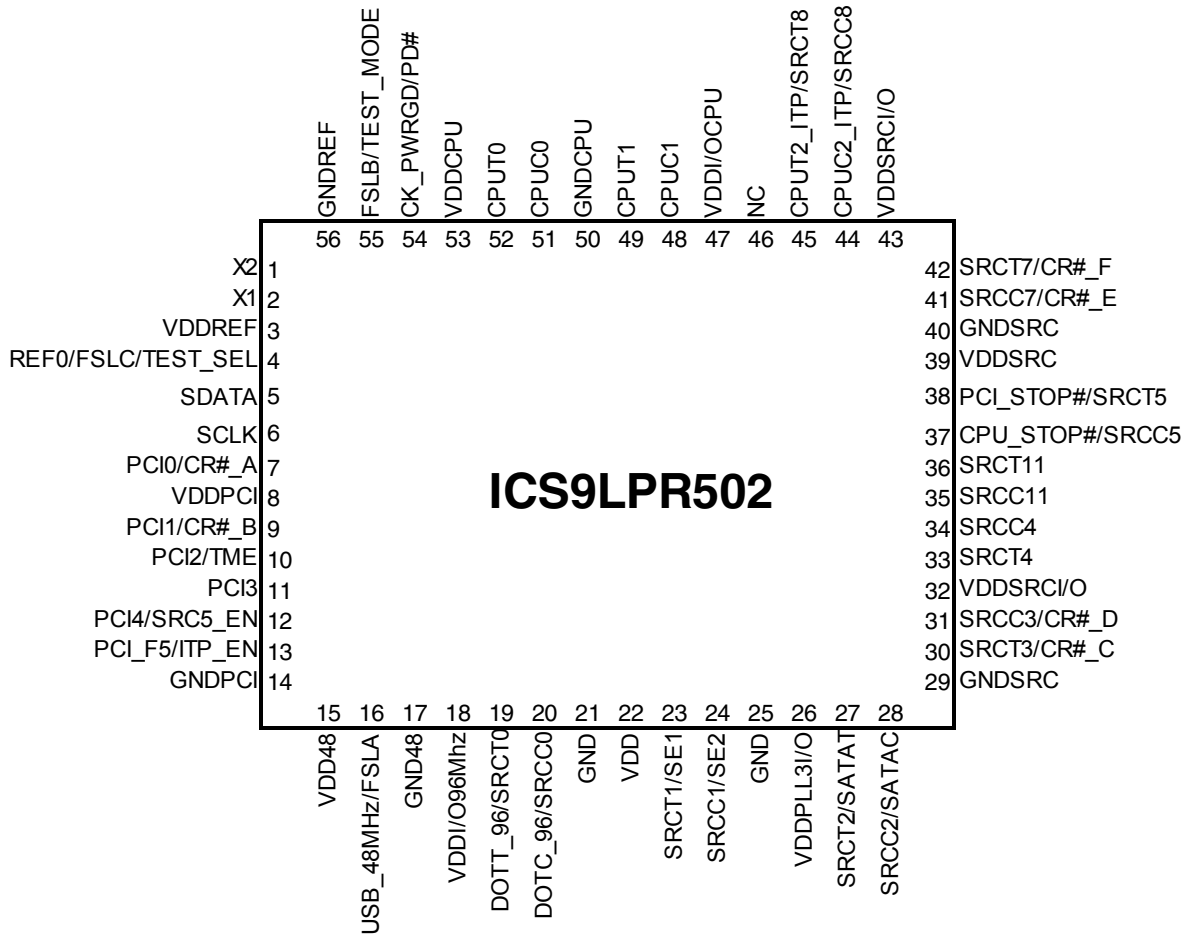

56-pin MLF

MLF Pin Description

PIN #	PIN NAME	TYPE	DESCRIPTION
1	X2	OUT	Crystal output, nominally 14.318MHz.
2	X1	IN	Crystal input, Nominally 14.318MHz.
3	VDDREF	PWR	Power pin for the REF outputs, 3.3V nominal.
4	REF0/FSLC/TEST_SEL	I/O	3.3V 14.318MHz reference clock/3.3V tolerant low threshold input for CPU frequency selection. Refer to input electrical characteristics for V_{il_FS} and V_{ih_FS} values/ TEST_SEL: 3-level latched input to enable test mode. Refer to Test Clarification Table.
5	SDATA	I/O	Data pin for SMBus circuitry, 5V tolerant.
6	SCLK	IN	Clock pin of SMBus circuitry, 5V tolerant.
7	PCI0/CR#_A	I/O	3.3V PCI clock output or Clock Request control A for either SRC0 or SRC2 pair The power-up default is PCI0 output, but this pin may also be used as a Clock Request control of SRC pair 0 or SRC pair 2 via SMBus. Before configuring this pin as a Clock Request Pin, the PCI output must first be disabled in byte 2, bit 0 of SMBus address space . After the PCI output is disabled (high-Z), the pin can then be set to serve as a Clock Request pin for either SRC pair 2 or pair 0 using the CR#_A_EN bit located in byte 5 of SMBus address space. Byte 5, bit 7 0 = PCI0 enabled (default) 1= CR#_A enabled. Byte 5, bit 6 controls whether CR#_A controls SRC0 or SRC2 pair Byte 5, bit 6 0 = CR#_A controls SRC0 pair (default), 1= CR#_A controls SRC2 pair
8	VDDPCI	PWR	Power supply pin for the PCI outputs, 3.3V nominal
9	PCI1/CR#_B	I/O	3.3V PCI clock output/Clock Request control B for either SRC1 or SRC4 pair The power-up default is PCI1 output, but this pin may also be used as a Clock Request control of SRC pair 1 or SRC pair 4 via SMBus. Before configuring this pin as a Clock Request Pin, the PCI output must first be disabled in byte 2, bit 1 of SMBus address space . After the PCI output is disabled (high-Z), the pin can then be set to serve as a Clock Request pin for either SRC pair 1 or pair 4 using the CR#_B_EN bit located in byte 5 of SMBus address space. Byte 5, bit 5 0 = PCI1 enabled (default) 1= CR#_B enabled. Byte 5, bit 6 controls whether CR#_B controls SRC1 or SRC4 pair Byte 5, bit 4 0 = CR#_B controls SRC1 pair (default) 1= CR#_B controls SRC4 pair
10	PCI2/TME	I/O	3.3V PCI clock output / Trusted Mode Enable (TME) Latched Input. This pin is sampled on power-up as follows 0 = Overclocking of CPU and SRC Allowed 1 = Overclocking of CPU and SRC NOT allowed After being sampled on power-up, this pin becomes a 3.3V PCI Output
11	PCI3	OUT	3.3V PCI clock output.
12	PCI4/SRC5_EN	I/O	3.3V PCI clock output / SRC5 pair or PCI_STOP#/CPU_STOP# enable strap. On powerup, the logic value on this pin determines if the SRC5 pair is enabled or if CPU_STOP#/PCI_STOP# is enabled (pins 29 and 30). The latched value controls the pin function on pins 29 and 30 as follows 0 = PCI_STOP#/CPU_STOP# 1 = SRC5/SRC5#
13	PCI_F5/ITP_EN	I/O	Free running PCI clock output and ITP/SRC8 enable strap. This output is not affected by the state of the PCI_STOP# pin. On powerup, the state of this pin determines whether pins 38 and 39 are an ITP or SRC pair. 0 =SRC8/SRC8# 1 = ITP/ITP#
14	GNDPCI	PWR	Ground for PCI clocks.

MLF Pin Description (Continued)

PIN #	PIN NAME	TYPE	DESCRIPTION
15	VDD48	PWR	Power supply for USB clock, nominal 3.3V.
16	USB_48MHz/FSLA	I/O	Fixed 48MHz USB clock output. 3.3V./ 3.3V tolerant input for CPU frequency selection. Refer to input electrical characteristics for V_{il_FS} and V_{ih_FS} values.
17	GND48	PWR	Ground pin for the 48MHz outputs.
18	VDD96_IO	PWR	Power supply for DOT96 output. 1.05 to 3.3V +/-5%.
19	DOTT_96/SRCT0	OUT	True clock of SRC or DOT96. The power-up default function is SRC0. After powerup, this pin function may be changed to DOT96 via SMBus Byte 1, bit 7 as follows: 0= SRC0 1=DOT96
20	DOTC_96/SRCC0	OUT	Complement clock of SRC or DOT96. The power-up default function is SRC0#. After powerup, this pin function may be changed to DOT96# via SMBus Byte 1, bit 7 as follows 0= SRC0# 1=DOT96#
21	GND	PWR	Ground pin for the DOT96 clocks.
22	VDD	PWR	Power supply for SRC / SE1 and SE2 clocks, 3.3V nominal.
23	SRCT1/SE1	OUT	True clock of differential SRC1 clock pair / 3.3V single-ended output. The powerup default is 100 MHz SRC, -0.5% downspread. The pin function may be changed via SMBus B1b[4:1]
24	SRCC1/SE2	OUT	Complement clock of differential SRC1 clock pair / 3.3V single-ended output. The powerup default is 100 MHz SRC, -0.5% downspread. The pin function may be changed via SMBus B1b[4:1]
25	GND	PWR	Ground pin for SRC / SE1 and SE2 clocks, PLL3.
26	VDDPLL3_IO	PWR	Power supply for PLL3 output. 1.05 to 3.3V +/-5%.
27	SRCT2/SATAT	OUT	True clock of differential SRC/SATA clock pair.
28	SRCC2/SATAC	OUT	Complement clock of differential SRC/SATA clock pair.

MLF Pin Description (Continued)

PIN #	PIN NAME	TYPE	DESCRIPTION
29	GNDSRC	PWR	Ground pin for SRC clocks.
30	SRCT3/CR#_C	I/O	True clock of differential SRC clock pair/ Clock Request control C for either SRC0 or SRC2 pair The power-up default is SRCCLK3 output, but this pin may also be used as a Clock Request control of SRC pair 0 or SRC pair 2 via SMBus. Before configuring this pin as a Clock Request Pin, the SRC3 output must first be disabled in byte 4, bit 7 of SMBus address space . After the SRC3 output is disabled, the pin can then be set to serve as a Clock Request pin for either SRC pair 2 or pair 0 using the CR#_C_EN bit located in byte 5 of SMBUS address space. Byte 5, bit 3 0 = SRC3 enabled (default) 1= CR#_C enabled. Byte 5, bit 2 controls whether CR#_C controls SRC0 or SRC2 pair Byte 5, bit 2 0 = CR#_C controls SRC0 pair (default), 1= CR#_C controls SRC2 pair
31	SRCC3/CR#_D	I/O	Complementary clock of differential SRC clock pair/ Clock Request control D for either SRC1 or SRC4 pair The power-up default is SRCCLK3 output, but this pin may also be used as a Clock Request control of SRC pair 1 or SRC pair 4 via SMBus. Before configuring this pin as a Clock Request Pin, the SRC3 output must first be disabled in byte 4, bit 7 of SMBus address space . After the SRC3 output is disabled, the pin can then be set to serve as a Clock Request pin for either SRC pair 1 or pair 4 using the CR#_D_EN bit located in byte 5 of SMBUS address space. Byte 5, bit 1 0 = SRC3 enabled (default) 1= CR#_D enabled. Byte 5, bit 0 controls whether CR#_D controls SRC1 or SRC4 pair Byte 5, bit 0 0 = CR#_D controls SRC1 pair (default), 1= CR#_D controls SRC4 pair
32	VDDSRC_IO	PWR	Power supply for SRC outputs. 1.05 to 3.3V +/-5%.
33	SRCT4	I/O	True clock of differential SRC clock pair 4
34	SRCC4	I/O	Complement clock of differential SRC clock pair 4
35	SRCC11	OUT	Complement clock of low power differential SRC clock pair.
36	SRCT11	OUT	True clock of low power differential SRC clock pair.
37	CPU_STOP#/SRCC5	I/O	Stops all CPU Clocks, except those set to be free running clocks / Complement clock of differential SRC pair. The function of this pin is set up by the power-up strap on pin 6, PCI4/SRC5_EN. The logic value sampled on pin 6 at power-up sets the function as follows: 0= CPU_STOP# 1 = SRC5 In AMT mode 3 bits are shifted in from the ICH to set the FSC, FSB, FSA values
38	PCI_STOP#/SRCT5	I/O	Stops all PCI Clocks, except those set to be free running clocks / Complement clock of differential SRC pair. The function of this pin is set up by the power-up strap on pin 6, PCI4/SRC5_EN. The logic value sampled on pin 6 at power-up sets the function as follows: 0= PCI_STOP# 1 = SRC5# In AMT mode, this pin is a clock input which times the FSC, FSB, FSA bits shifted in on pin 37.
39	VDDSRC	PWR	VDD pin for SRC Pre-drivers, 3.3V nominal
40	GNDSRC	PWR	Ground for SRC clocks
41	SRCC7/CR#_E	I/O	SRC7 complement or Clock Request control E for SRC6 pair The power-up default is SRC7#, but this pin may also be used as a Clock Request control of SRC6 via SMBus. Before configuring this pin as a Clock Request Pin, the SRC7 output pair must first be disabled in byte 3, bit 3 of SMBus configuration space . After the SRC output is disabled (high-Z), the pin can then be set to serve as a Clock Request for SRC6 pair using byte 6, bit 7 of SMBus configuration space Byte 6, bit 7 0 = SRC7# enabled (default) 1= CR#_E controls SRC6.
42	SRCT7/CR#_F	I/O	SRC7 true or Clock Request control 8 for SRC8 pair The power-up default is SRC7, but this pin may also be used as a Clock Request control of SRC8 via SMBus. Before configuring this pin as a Clock Request Pin, the SRC7 output pair must first be disabled in byte 3, bit 3 of SMBus configuration space After the SRC output is disabled (high-Z), the pin can then be set to serve as a Clock Request for SRC8 pair using byte 6, bit 6 of SMBus configuration space Byte 6, bit 6 0 = SRC7# enabled (default) 1 = CR#_F controls SRC8.

MLF Pin Description (Continued)

PIN #	PIN NAME	TYPE	DESCRIPTION
43	VDDSRC_IO	PWR	Power supply for SRC outputs. 1.05 to 3.3V +/-5%.
44	CPUC2_ITP/SRCC8	OUT	Complement clock of low power differential CPU2/Complement clock of differential SRC pair. The function of this pin is determined by the latched input value on pin 7, PCIF5/ITP_EN on powerup. The function is as follows: Pin 7 latched input Value 0 = SRC8# 1 = ITP#
45	CPUT2_ITP/SRCT8	OUT	True clock of low power differential CPU2/True clock of differential SRC pair. The function of this pin is determined by the latched input value on pin 7, PCIF5/ITP_EN on powerup. The function is as follows: Pin 7 latched input Value 0 = SRC8 1 = ITP
46	NC	NC	Not Connected
47	VDDCPU_IO	PWR	Power supply for CPU outputs. 1.05 to 3.3V +/-5%.
48	CPUC1_F	OUT	Complement clock of low power differential CPU clock pair. This clock will be free-running during iAMT.
49	CPUT1_F	OUT	True clock of low power differential CPU clock pair. This clock will be free-running during iAMT.
50	GNDCPU	PWR	Ground Pin for CPU Outputs
51	CPUC0	OUT	Complement clock of low power differential CPU clock pair.
52	CPUT0	OUT	True clock of low power differential CPU clock pair.
53	VDDCPU	PWR	Power Supply 3.3V nominal.
54	CK_PWRGD/PD#	IN	Notifies CK505 to sample latched inputs, or iAMT entry/exit, or PWRDWN# mode
55	FSLB/TEST_MODE	IN	3.3V tolerant input for CPU frequency selection. Refer to input electrical characteristics for V_{il_FS} and V_{ih_FS} values. TEST_MODE is a real time input to select between Hi-Z and REF/N divider mode while in test mode. Refer to Test Clarification Table.
56	GNDREF	PWR	Ground pin for crystal oscillator circuit

General Description

ICS9LPR502 follows Intel CK505 Yellow Cover specification. This clock synthesizer provides a single chip solution for next generation Intel processors and Intel chipsets. ICS9LPR502 is driven with a 14.318MHz crystal. It also provides a tight ppm accuracy output for Serial ATA and PCI-Express support.

Functional Block Diagram

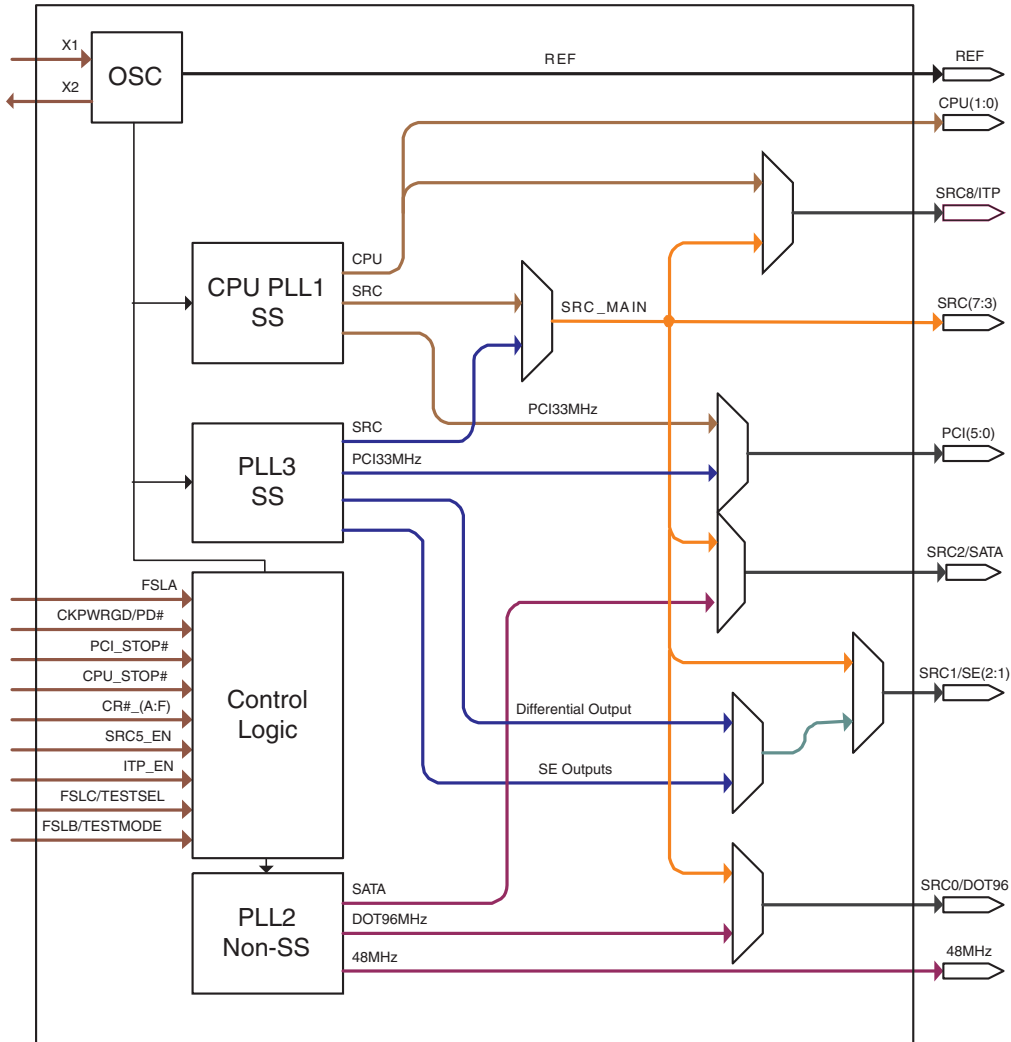

Power Groups

Pin Number		Description	
VDD	GND		
41	44	CPUCLK	Low power outputs
47	44	Master Clock, Analog	
26, 37	23,34	SRCCLK	Low power outputs
31	23,34		PLL 1
20	19	PLL3/SE	Low power outputs
16	19		PLL 3
12	11	DOT 96Mhz	Low power outputs
9	11	USB 48	
53	50	Xtal, REF	
2	8	PCICLK	

Absolute Maximum Ratings - DC Parameters

PARAMETER	SYMBOL	CONDITIONS	MIN	MAX	UNITS	Notes
Maximum Supply Voltage	VDDxxx	Supply Voltage		4.6	V	7
Maximum Supply Voltage	VDDxxx_IO	Low-Voltage Differential I/O Supply		3.8	V	7
Maximum Input Voltage	V _{IH}	3.3V Inputs		4.6	V	4,5,7
Minimum Input Voltage	V _{IL}	Any Input	GND - 0.5		V	4,7
Storage Temperature	T _s	-	-65	150	°C	4,7
Input ESD protection	ESD prot	Human Body Model	2000		V	6,7

¹Guaranteed by design and characterization, not 100% tested in production.

²Operation under these conditions is neither implied, nor guaranteed.

³Maximum input voltage is not to exceed VDD

Electrical Characteristics - Input/Supply/Common Output DC Parameters

PARAMETER	SYMBOL	CONDITIONS	MIN	MAX	UNITS	Notes
Ambient Operating Temp	Tambient	-	0	70	°C	
Supply Voltage	VDDxxx	Supply Voltage	3.135	3.465	V	
Supply Voltage	VDDxxx_IO	Low-Voltage Differential I/O Supply	0.9975	3.465	V	10
Input High Voltage	V _{IHSE}	Single-ended 3.3V inputs	2	V _{DD} + 0.3	V	3
Input Low Voltage	V _{ILSE}	Single-ended 3.3V inputs	V _{SS} - 0.3	0.8	V	3
Low Threshold Input- High Voltage	V _{IH_FS_TEST}	3.3 V +/-5%	2	VDD + 0.3	V	8
Low Threshold Input- FSC = '1' Voltage	V _{IH_FS_FSC}	3.3 V +/-5%	0.7	1.5	V	8
Low Threshold Input- FSA,FSB = '1' Voltage	V _{IH_FS_FSAB}	3.3 V +/-5%	0.7	VDD+0.3	V	
Low Threshold Input-Low Voltage	V _{IL_FS}	3.3 V +/-5%	V _{SS} - 0.3	0.35	V	
PCI3/CFG0 Input	V _{IL_CFGHI}	Optional input, 2.75V typ.	2.4	VDD+0.3	V	9
PCI3/CFG0 Input	V _{IL_CFGMID}	Optional input, 1.65V typ.	1.3	2	V	9
PCI3/CFG0 Input	V _{IL_CFGLO}	Optional input, 0.55V typ.	V _{SS} - 0.3	0.9	V	9
Input Leakage Current	I _{IN}	V _{IN} = V _{DD} , V _{IN} = GND	-5	5	uA	2
Input Leakage Current	I _{INRES}	Inputs with pull up or pull down resistors V _{IN} = V _{DD} , V _{IN} = GND	-200	200	uA	
Output High Voltage	V _{OHSE}	Single-ended outputs, I _{OH} = -1mA	2.4		V	1
Output Low Voltage	V _{OLSE}	Single-ended outputs, I _{OL} = 1 mA		0.4	V	1
Operating Supply Current	I _{DDOP3.3}	Full Active, C _L = Full load; I _{DD} 3.3V		200	mA	
	I _{DDPIO}	Full Active, C _L = Full load; I _{DD} IO		70	mA	10
iAMT Mode Current	I _{DDIAMT3.3}	M1 mode, 3.3V Rail		80	mA	
	I _{DDIAMTIO}	M1 Mode, IO Rail		10	mA	
Powerdown Current	I _{DDPD3.3}	Power down mode, 3.3V Rail		5	mA	
	I _{DDPDIO}	Power down mode, IO Rail		0.1	mA	10
Input Frequency	F _i	V _{DD} = 3.3 V		15	MHz	
Pin Inductance	L _{pin}			7	nH	
Input Capacitance	C _{IN}	Logic Inputs	1.5	5	pF	
	C _{OUT}	Output pin capacitance		6	pF	
	C _{INX}	X1 & X2 pins		6	pF	
Clk Stabilization	T _{STAB}	From VDD Power-Up or de-assertion of PD to 1st clock		1.8	ms	
Tdrive_CR_off	T _{DRCROFF}	Output stop after CR deasserted		400	ns	
Tdrive_CR_on	T _{DRCRON}	Output run after CR asserted		0	us	
Tdrive_CPU	T _{DRSRC}	CPU output enable after PCI_STOP# de-assertion		10	ns	
Tfall_SE	T _{FALL}	Fall/rise time of all 3.3V control inputs from 20-80%		10	ns	
Trise_SE	T _{RISE}			10	ns	
SMBus Voltage	V _{DD}		2.7	5.5	V	
Low-level Output Voltage	V _{OLSMB}	@ I _{PULLUP}		0.4	V	
Current sinking at V _{OLSMB} = 0.4 V	I _{PULLUP}	SMB Data Pin	4		mA	
SCLK/SDATA Clock/Data Rise Time	T _{R12C}	(Max VIL - 0.15) to (Min VIH + 0.15)		1000	ns	
SCLK/SDATA Clock/Data Fall Time	T _{F12C}	(Min VIH + 0.15) to (Max VIL - 0.15)		300	ns	
Maximum SMBus Operating Frequency	F _{SMBUS}			100	kHz	
Spread Spectrum Modulation Frequency	f _{SSMOD}	Triangular Modulation	30	33	kHz	

Electrical Characteristics - Input/Supply/Common Output DC ParametersDC Parameters: (unless otherwise noted, guaranteed by design and characterization, not 100% tested in production).

¹Signal is required to be monotonic in this region.

²input leakage current does not include inputs with pull-up or pull-down resistors

³3.3V referenced inputs are: PCI_STOP#, CPU_STOP#, TME, SRC5_EN, ITP_EN, SCLKL, SDATA, TESTMODE, TESTSEL, CKPWRGD and CR# inputs if selected.

⁴Intentionally blank

⁵Maximum VIH is not to exceed VDD

⁶Human Body Model

⁷Operation under these conditions is neither implied, nor guaranteed.

⁸Frequency Select pins which have tri-level input

⁹PCI3/CFG0 is optional

¹⁰If present. Not all parts have this feature.

AC Electrical Characteristics - Low Power Differential Outputs

PARAMETER	SYMBOL	CONDITIONS	MIN	MAX	UNITS	NOTES
Rising Edge Slew Rate	tSLR	Averaging on	2.5	4	V/ns	2, 3
Falling Edge Slew Rate	tFLR	Averaging on	2.5	4	V/ns	2, 3
Slew Rate Variation	tSLVAR	Averaging on		20	%	1, 10
Differential Voltage Swing	VSWING	Averaging off	300		mV	2
Crossing Point Voltage	VXABS	Averaging off	300	550	mV	1,4,5
Crossing Point Variation	VXABSVAR	Averaging off		140	mV	1,4,9
Maximum Output Voltage	VHIGH	Averaging off		1150	mV	1,7
Minimum Output Voltage	VLOW	Averaging off	-300		mV	1,8
Duty Cycle	DCYC	Averaging on	45	55	%	2
CPU Skew	CPUSKEW	Averaging on		100	ps	
CPU[1:0] Skew	CPUSKEW10	Differential Measurement		100	ps	1
CPU[2_ITP:0] Skew	CPUSKEW20	Differential Measurement		150	ps	1
SRC[10:0] Skew	SRCSKEW	Differential Measurement		3000	ps	1,6,11

NOTES on DIF Output AC Specs: (unless otherwise noted, guaranteed by design and characterization, not 100% tested in production).

¹Measurement taken for single ended waveform on a component test board (not in system)

²Measurement taken from differential waveform on a component test board. (not in system)

³Slew rate emasured through V_swing voltage range centered about differential zero

⁴Vcross is defined at the voltage where Clock = Clock#, measured on a component test board (not in system)

⁵Only applies to the differential rising edge (Clock rising, Clock# falling)

⁶Total distributed intentional SRC to SRC skew. PCIe Gen2 outputs (SRC3, 4, 6 and 7) will have 0 nominal skew. Maximum allowable interpair skew is 150 ps.

⁷The max voltage including overshoot.

⁸The min voltage including undershoot.

⁹The total variation of all Vcross measurements in any particular system. Note this is a subset of V_cross min/mas (V_Cross absolute) allowed. The intent is to limit Vcross induced

¹⁰Matching applies to rising edge rate for Clock and falling edge rate for Clock#. It is measured using a +/-75mV window centered on the average cross point where Clock rising meets

¹¹For PCIe Gen2 compliant devices, SRC 3, 4, 6, and 7 will have 0 ps nominal skew.

Clock Jitter Specs - Low Power Differential Outputs

PARAMETER	SYMBOL	CONDITIONS	MIN	MAX	UNITS	NOTES
CPU Jitter - Cycle to Cycle	CPUJC2C	Differential Measurement		85	ps	1
SRC Jitter - Cycle to Cycle	SRCJC2C	Differential Measurement		125	ps	1,2
DOT Jitter - Cycle to Cycle	DOTJC2C	Differential Measurement		250	ps	1

NOTES on DIF Output Jitter: (unless otherwise noted, guaranteed by design and characterization, not 100% tested in production).

¹Jitter specs are specified as measured on a clock characterization board. System designers need to take special care not to use these numbers, as the in-system performance will be somewhat degraded. The receiver EMTS (chispet or CPU) will have the rece

²Phase jitter requirement: The designated Ge2 outputs will meet the reference clock jitter requirements from the PCI Express Gen2 Base Spec. The test is performed on a component test board under quiet conditions with all outputs on. Jitter analysis is performed using a standardized tool provided by the PCI SIG or equivalent. Measurement methodology is as defined by the PCI SIG.

Electrical Characteristics - PCICLK/PCICLK_F

PARAMETER	SYMBOL	CONDITIONS	MIN	MAX	UNITS	NOTES
Long Accuracy	ppm	see Tperiod min-max values	-100	100	ppm	1,2
Clock period	T _{period}	33.33MHz output no spread	29.99700	30.00300	ns	2
		33.33MHz output spread	30.08421	30.23459	ns	2
Absolute min/max period	T _{abs}	33.33MHz output no spread	29.49700	30.50300	ns	2
		33.33MHz output nominal/spread	29.56617	30.58421	ns	2
Output High Voltage	V _{OH}	I _{OH} = -1 mA	2.4		V	1
Output Low Voltage	V _{OL}	I _{OL} = 1 mA		0.55	V	1
Output High Current	I _{OH}	V _{OH} @ MIN = 1.0 V	-33		mA	1
		V _{OH} @ MAX = 3.135 V		-33	mA	1
Output Low Current	I _{OL}	V _{OL} @ MIN = 1.95 V	30		mA	1
		V _{OL} @ MAX = 0.4 V		38	mA	1
Rising Edge Slew Rate	t _{SLR}	Measured from 0.8 to 2.0 V	1	4	V/ns	1
Falling Edge Slew Rate	t _{FLR}	Measured from 2.0 to 0.8 V	1	4	V/ns	1
Pin to Pin Skew	t _{skew}	V _T = 1.5 V		250	ps	2
Intentional PCI to PCI delay	t _{skew}	V _T = 1.5 V	100	200	ps	2
Duty Cycle	d _{t1}	V _T = 1.5 V	45	55	%	2
Jitter, Cycle to cycle	t _{jcy-cyc}	V _T = 1.5 V		500	ps	2

Intentional PCI Clock to Clock Delay

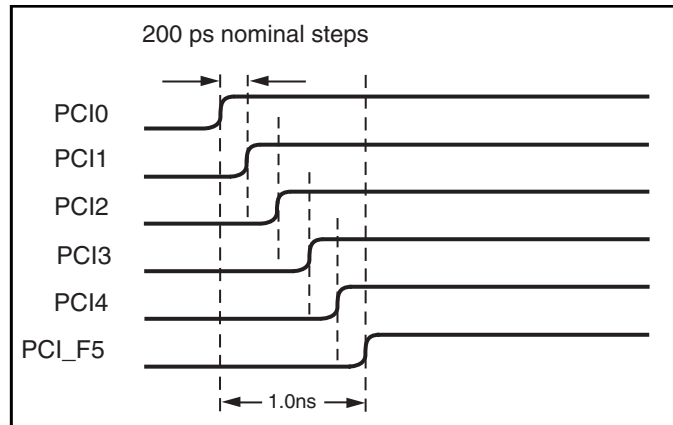

Electrical Characteristics - USB48MHz

PARAMETER	SYMBOL	CONDITIONS	MIN	MAX	UNITS	NOTES
Long Accuracy	ppm	see Tperiod min-max values	-100	100	ppm	2,4
Clock period	T _{period}	48.00MHz output nominal	20.83125	20.83542	ns	2,3
Absolute min/max period	T _{abs}	48.00MHz output nominal	20.48125	21.18542	ns	2
CLK High Time	T _{HIGH}		8.216563	11.15198	V	
CLK Low time	T _{LOW}		7.816563	10.95198	V	
Output High Voltage	V _{OH}	I _{OH} = -1 mA	2.4		V	
Output Low Voltage	V _{OL}	I _{OL} = 1 mA		0.55	V	
Output High Current	I _{OH}	V _{OH} @ MIN = 1.0 V	-29		mA	
		V _{OH} @ MAX = 3.135 V		-23	mA	
Output Low Current	I _{OL}	V _{OL} @ MIN = 1.95 V	29		mA	
		V _{OL} @ MAX = 0.4 V		27	mA	
Rising Edge Slew Rate	t _{SLR}	Measured from 0.8 to 2.0 V	1	2	V/ns	1
Falling Edge Slew Rate	t _{FLR}	Measured from 2.0 to 0.8 V	1	2	V/ns	1
Duty Cycle	d _{t1}	V _T = 1.5 V	45	55	%	2
Jitter, Cycle to cycle	t _{jcy-cyc}	V _T = 1.5 V		350	ps	2

Electrical Characteristics - REF-14.318MHz

PARAMETER	SYMBOL	CONDITIONS	MIN	MAX	UNITS	Notes
Long Accuracy	ppm	see Tperiod min-max values	-100	100	ppm	2, 4
Clock period	Tperiod	14.318MHz output nominal	69.82033	69.86224	ns	2, 3
Absolute min/max period	Tab	14.318MHz output nominal	69.83400	70.84800	ns	2
CLK High Time	THIGH		29.97543	38.46654	V	
CLK Low time	TLOW		29.57543	38.26654	V	
Output High Voltage	VOH	IOH = -1 mA	2.4		V	
Output Low Voltage	VOL	IOL = 1 mA		0.4	V	
Output High Current	IOH	VOH @MIN = 1.0 V, VOH@MAX = 3.135 V	-33	-33	mA	
Output Low Current	IOL	VOL @MIN = 1.95 V, VOL @MAX = 0.4 V	30	38	mA	
Rising Edge Slew Rate	tSLR	Measured from 0.8 to 2.0 V	1	4	V/ns	1
Falling Edge Slew Rate	tFLR	Measured from 2.0 to 0.8 V	1	4	V/ns	1
Duty Cycle	dt1	VT = 1.5 V	45	55	%	2
Jitter, Cycle to cycle	tjcy-cyc	VT = 1.5 V		1000	ps	2

NOTES on SE outputs: (unless otherwise noted, guaranteed by design and characterization, not 100% tested in production).

¹Edge rate in system is measured from 0.8V to 2.0V.

²Duty cycle, Period and Jitter are measured with respect to 1.5V

³The average period over any 1us period of time

⁴Using frequency counter with the measurement interval equal or greater that 0.15s, target frequencies are 14.318180 MHz, 33.333333MHz and 48.000000MHz

Table 1: CPU Frequency Select Table

FS _L C ² B0b7	FS _L B ¹ B0b6	FS _L A ¹ B0b5	CPU MHz	SRC MHz	PCI MHz	REF MHz	USB MHz	DOT MHz
0	0	0	266.66	100.00	33.33	14.318	48.00	96.00
0	0	1	133.33					
0	1	0	200.00					
0	1	1	166.66					
1	0	0	333.33					
1	0	1	100.00					
1	1	0	400.00					
1	1	1	Reserved					

- FS_LA and FS_LB are low-threshold inputs. Please see V_{IL_FS} and V_{IH_FS} specifications in the Input/Supply/Common Output Parameters Table for correct values.
Also refer to the Test Clarification Table.
- FS_LC is a three-level input. Please see the V_{IL_FS} and V_{IH_FS} specifications in the Input/Supply/Common Output Parameters Table for correct values.

Table 2: PLL3 Quick Configuration

B1b4	B1b3	B1b2	B1b1	Pin 17	Pin 18	Spread	Comment
				MHz	MHz	%	
0	0	0	0	PLL 3 disabled			
0	0	0	1	100.00	100.00	0.5% Down Spread	SRCCLK1 from SRC_MAIN
0	0	1	0	100.00	100.00	0.5% Down Spread	Only SRCCLK1 from PLL3
0	0	1	1	100.00	100.00	1% Down Spread	Only SRCCLK1 from PLL3
0	1	0	0	100.00	100.00	1.5% Down Spread	Only SRCCLK1 from PLL3
0	1	0	1	100.00	100.00	2% Down Spread	Only SRCCLK1 from PLL3
0	1	1	0	100.00	100.00	2.5% Down Spread	Only SRCCLK1 from PLL3
0	1	1	1	N/A	N/A	N/A	N/A
1	0	0	0	24.576	24.576	None	24.576Mhz on SE1 and SE2
1	0	0	1	24.576	98.304	None	24.576Mhz on SE1, 98.304Mhz on SE2
1	0	1	0	98.304	98.304	None	98.304Mhz on SE1 and SE2
1	0	1	1	27.000	27.000	None	27Mhz on SE1 and SE2
1	1	0	0	25.000	25.000	None	25Mhz on SE1 and SE2
1	1	0	1	N/A	N/A	N/A	N/A
1	1	1	0	N/A	N/A	N/A	N/A
1	1	1	1	N/A	N/A	N/A	N/A

Table 3: IO_Vout select table

B9b2	B9b1	B9b0	IO_Vout
0	0	0	0.3V
0	0	1	0.4V
0	1	0	0.5V
0	1	1	0.6V
1	0	0	0.7V
1	0	1	0.8V
1	1	0	0.9V
1	1	1	1.0V

Table 4: Device ID table

B8b7	B8b6	B8b5	B8b4	Comment
0	0	0	0	56 pin TSSOP/QFN
0	0	0	1	64 pin TSSOP/QFN
0	0	1	0	Reserved
0	0	1	1	Reserved
0	1	0	0	Reserved
0	1	0	1	Reserved
0	1	1	0	Reserved
0	1	1	1	Reserved
1	0	0	0	Reserved
1	0	0	1	Reserved
1	0	1	0	Reserved
1	0	1	1	Reserved
1	1	0	0	Reserved
1	1	0	1	Reserved
1	1	1	0	Reserved
1	1	1	1	Reserved

PCI_STOP# Power Management

SMBus OE Bit	PCI_STOP#	Stop Drive Mode	Single-ended Clocks		Differential Clocks (Except CPU)	
			Stoppable	Free running	Stoppable	Free running
Enable	1	X	Running	Running	Running	Running
	0	0	Low	Low	CK= High CK# = Low	Running
		1			CK= Pull down CK# = Low	Running
Disable	X	X	Low		CK= Pull down, CK# = Low	

CPU_STOP# Power Management

SMBus OE Bit	PCI_STOP#	Stop Drive Mode	Differential Clocks	
			Stoppable	Free running
Enable	1	X	Running	Running
	0	0	CK= High CK# = Low	Running
		1	CK= Pull down CK# = Low	Running
Disable	X	X	Low	

CR# Power Management

SMBus OE Bit	CR#	Stop Drive Mode	Differential Clocks	
			Stoppable	Free running
Enable	1	X	Running	Running
	0		CK= Pull down, CK# = Low	
Disable	X		CK = Pull down, CK# = Low	

PD# Power Management

Device State	Single-ended Clocks		Differential Clocks (Except CPU1)	CPU1
	w/o Latched input	w/Latched input		
Latches Open	Low	Hi-Z	CK= Pull down, CK# = Low	CK= Pull down, CK# = Low
Power Down			CK= Pull down CK# = Low	CK= Pull down CK# = Low
M1			CK= Pull down CK# = Low	Running
Virtual Power Cycle to Latches Open			CK= Pull down, CK# = Low	CK= Pull down, CK# = Low

General SMBus serial interface information for the ICS9LPR502

How to Write:

- Controller (host) sends a start bit.
- Controller (host) sends the write address $D2_{(H)}$
- ICS clock will **acknowledge**
- Controller (host) sends the beginning byte location = N
- ICS clock will **acknowledge**
- Controller (host) sends the data byte count = X
- ICS clock will **acknowledge**
- Controller (host) starts sending **Byte N through Byte N + X - 1**
- ICS clock will **acknowledge** each byte **one at a time**
- Controller (host) sends a Stop bit

How to Read:

- Controller (host) will send start bit.
- Controller (host) sends the write address $D2_{(H)}$
- ICS clock will **acknowledge**
- Controller (host) sends the beginning byte location = N
- ICS clock will **acknowledge**
- Controller (host) will send a separate start bit.
- Controller (host) sends the read address $D3_{(H)}$
- ICS clock will **acknowledge**
- ICS clock will send the data byte count = X
- ICS clock sends **Byte N + X - 1**
- ICS clock sends **Byte 0 through byte X (if $X_{(H)}$ was written to byte 8).**
- Controller (host) will need to acknowledge each byte
- Controller (host) will send a not acknowledge bit
- Controller (host) will send a stop bit

Index Block Write Operation		
Controller (Host)		ICS (Slave/Receiver)
T	starT bit	
Slave Address $D2_{(H)}$		
WR	WRite	
		ACK
Beginning Byte = N		
		ACK
Data Byte Count = X		
		ACK
Beginning Byte N	X Byte	
○		ACK
○		○
○		○
Byte N + X - 1		○
		ACK
P	stoP bit	

Index Block Read Operation		
Controller (Host)		ICS (Slave/Receiver)
T	starT bit	
Slave Address $D2_{(H)}$		
WR	WRite	
		ACK
Beginning Byte = N		
		ACK
RT	Repeat starT	
Slave Address $D3_{(H)}$		
RD	ReaD	
		ACK
		Data Byte Count = X
ACK		
ACK		Beginning Byte N
○		○
○		○
○		○
		Byte N + X - 1
N	Not acknowledge	
P	stoP bit	

Byte 0 FS Readback and PLL Selection Register

Bit	Pin	Name	Description	Type	0	1	Default
7	-	FSLC	CPU Freq. Sel. Bit (Most Significant)	R	See Table 1 : CPU Frequency Select Table		Latch
6	-	FSLB	CPU Freq. Sel. Bit	R			Latch
5	-	FSLA	CPU Freq. Sel. Bit (Least Significant)	R			Latch
4	-	iAMT_EN	Set via SMBus or dynamically by CK505 if detects dynamic M1	RW	Legacy Mode	iAMT Enabled	0
3		Reserved	Reserved	RW			0
2	-	SRC_Main_SEL	Select source for SRC Main	RW	SRC Main = PLL1	SRC Main = PLL3	0
1	-	SATA_SEL	Select source for SATA clock	RW	SATA = SRC_Main	SATA = PLL2	0
0	-	PD_Restore	1 = on Power Down de-assert return to last known state 0 = clear all SMBus configurations as if cold power-on and go to latches open state This bit is ignored and treated at '1' if device is in iAMT mode.	RW	Configuration Not Saved	Configuration Saved	1

Byte 1 DOT96 Select and PLL3 Quick Config Register

Bit	Pin	Name	Description	Type	0	1	Default
7	13/14	SRC0_SEL	Select SRC0 or DOT96	RW	SRC0	DOT96	0
6	-	PLL1_SSC_SEL	Select 0.5% down or center SSC	RW	Down spread	Center spread	0
5		PLL3_SSC_SEL	Select 0.5% down or center SSC	RW	Down spread	Center spread	0
4		PLL3_CF3	PLL3 Quick Config Bit 3	RW	See Table 2: PLL3 Quick Configuration Only applies if Byte 0, bit 2 = 0.		0
3		PLL3_CF2	PLL3 Quick Config Bit 2	RW			0
2		PLL3_CF1	PLL3 Quick Config Bit 1	RW			0
1		PLL3_CF0	PLL3 Quick Config Bit 0	RW			1
0		PCI_SEL	PCI_SEL	RW	PCI from PLL1	PCI from SRC_MAIN	1

Byte 2 Output Enable Register

Bit	Pin	Name	Description	Type	0	1	Default
7		REF_OE	Output enable for REF, if disabled output is tri-stated	RW	Output Disabled	Output Enabled	1
6		USB_OE	Output enable for USB	RW	Output Disabled	Output Enabled	1
5		PCIF5_OE	Output enable for PCI5	RW	Output Disabled	Output Enabled	1
4		PCI4_OE	Output enable for PCI4	RW	Output Disabled	Output Enabled	1
3		PCI3_OE	Output enable for PCI3	RW	Output Disabled	Output Enabled	1
2		PCI2_OE	Output enable for PCI2	RW	Output Disabled	Output Enabled	1
1		PCI1_OE	Output enable for PCI1	RW	Output Disabled	Output Enabled	1
0		PCI0_OE	Output enable for PCI0	RW	Output Disabled	Output Enabled	1

Byte 3 Output Enable Register

Bit	Pin	Name	Description	Type	0	1	Default
7		SRC11_OE	Output enable for SRC11	RW	Output Disabled	Output Enabled	1
6		SRC10_OE	Output enable for SRC10	RW	Output Disabled	Output Enabled	1
5		SRC9_OE	Output enable for SRC9	RW	Output Disabled	Output Enabled	1
4		SRC8/ITP_OE	Output enable for SRC8 or ITP	RW	Output Disabled	Output Enabled	1
3		SRC7_OE	Output enable for SRC7	RW	Output Disabled	Output Enabled	1
2		SRC6_OE	Output enable for SRC6	RW	Output Disabled	Output Enabled	1
1		SRC5_OE	Output enable for SRC5	RW	Output Disabled	Output Enabled	1
0		SRC4_OE	Output enable for SRC4	RW	Output Disabled	Output Enabled	1

Byte 4 Output Enable and Spread Spectrum Disable Register

Bit	Pin	Name	Description	Type	0	1	Default
7		SRC3_OE	Output enable for SRC3	RW	Output Disabled	Output Enabled	1
6		SATA/SRC2_OE	Output enable for SATA/SRC2	RW	Output Disabled	Output Enabled	1
5		SRC1_OE	Output enable for SRC1	RW	Output Disabled	Output Enabled	1
4		SRC0/DOT96_OE	Output enable for SRC0/DOT96	RW	Output Disabled	Output Enabled	1
3		CPU1_OE	Output enable for CPU1	RW	Output Disabled	Output Enabled	1
2		CPU0_OE	Output enable for CPU0	RW	Output Disabled	Output Enabled	1
1		PLL1_SSC_ON	Enable PLL1's spread modulation	RW	Spread Disabled	Spread Enabled	1
0		PLL3_SSC_ON	Enable PLL3's spread modulation	RW	Spread Disabled	Spread Enabled	1

Byte 5 Clock Request Enable/Configuration Register

Bit	Pin	Name	Description	Type	0	1	Default
7		CR#_A_EN	Enable CR#_A (clk req), PCI0_OE must be = 1 for this bit to take effect	RW	Disable CR#_A	Enable CR#_A	0
6		CR#_A_SEL	Sets CR#_A to control either SRC0 or SRC2	RW	CR#_A -> SRC0	CR#_A -> SRC2	0
5		CR#_B_EN	Enable CR#_B (clk req)	RW	Disable CR#_B	Enable CR#_B	0
4		CR#_B_SEL	Sets CR#_B -> SRC1 or SRC4	RW	CR#_B -> SRC1	CR#_B -> SRC4	0
3		CR#_C_EN	Enable CR#_C (clk req)	RW	Disable CR#_C	Enable CR#_C	0
2		CR#_C_SEL	Sets CR#_C -> SRC0 or SRC2	RW	CR#_C -> SRC0	CR#_C -> SRC2	0
1		CR#_D_EN	Enable CR#_D (clk req)	RW	Disable CR#_D	Enable CR#_D	0
0		CR#_D_SEL	Sets CR#_D -> SRC1 or SRC4	RW	CR#_D -> SRC1	CR#_D -> SRC4	0

Byte 6 Clock Request Enable/Configuration and Stop Control Register

Bit	Pin	Name	Description	Type	0	1	Default
7		CR#_E_EN	Enable CR#_E (clk req) -> SRC6	RW	Disable CR#_E	Enable CR#_E	0
6		CR#_F_EN	Enable CR#_F (clk req) -> SRC8	RW	Disable CR#_F	Enable CR#_F	0
5		CR#_G_EN	Enable CR#_G (clk req) -> SRC9	RW	Disable CR#_G	Enable CR#_G	0
4		CR#_H_EN	Enable CR#_H (clk req) -> SRC10	RW	Disable CR#_H	Enable CR#_H	0
3		Reserved	Reserved	RW			0
2		Reserved	Reserved	RW			0
1		SSCD_STP_CRTL (SRC1)	If set, SSCD (SRC1) stops with PCI_STOP#	RW	Free Running	Stops with PCI_STOP# assertion	0
0		SRC_STP_CRTL	If set, SRCs (except SRC1) stop with PCI_STOP#	RW	Free Running	Stops with PCI_STOP# assertion	0

Byte 7 Vendor ID/ Revision ID

Bit	Pin	Name	Description	Type	0	1	Default
7		Rev Code Bit 3	Revision ID	R	Vendor specific		X
6		Rev Code Bit 2		R			X
5		Rev Code Bit 1		R			X
4		Rev Code Bit 0		R			X
3		Vendor ID bit 3	Vendor ID ICS is 0001, binary	R			0
2		Vendor ID bit 2		R			0
1		Vendor ID bit 1		R			0
0		Vendor ID bit 0		R	1		

Byte 8 Device ID and Output Enable Register

Bit	Pin	Name	Description	Type	0	1	Default
7		Device_ID3	Table of Device identifier codes, used for differentiating between CK505 package options, etc.	R	See Device ID Table		0
6		Device_ID2		R			0
5		Device_ID1		R			0
4		Device_ID0		R			0
3		Reserved	Reserved	RW	-	-	0
2		Reserved	Reserved	RW	-	-	0
1		SE1_OE	Output enable for SE1	RW	Disabled	Enabled	0
0		SE2_OE	Output enable for SE2	RW	Disabled	Enabled	0

Byte 9 Output Control Register

Bit	Pin	Name	Description	Type	0	1	Default
7		PCIF5_STOP_EN	Allows control of PCIF5 with assertion of PCI_STOP#	RW	Free running	Stops with PCI_STOP# assertion	0
6		TME_Readback	Trusted Mode Enable (TME) strap status	R	normal operation	no overclocking	0
5		Reserved	Reserved	RW	-	-	1
4		Test Mode Select	Allows test select, ignores REF/FSC/TestSel	RW	Outputs HI-Z	Outputs = REF/N	0
3		Test Mode Entry	Allows entry into test mode, ignores FSB/TestMode	RW	Normal operation	Test mode	0
2		IO_VOUT2	IO Output Voltage Select (Most Significant Bit)	RW	See Table 3: V_IO Selection (Default is 0.8V)		1
1		IO_VOUT1	IO Output Voltage Select	RW			0
0		IO_VOUT0	IO Output Voltage Select (Least Significant Bit)	RW			1

Byte 10 CK505 Rev 0.85 functions (ICS Rev H silicon and higher)

Bit	Pin	Name	Description	Type	0	1	Default
7		SRC5_EN Readback	Readback of SRC5 enable latch	R	CPU/PCI Stop Enabled	SRC5 Enabled	Latch
6		Reserved	Reserved	RW	TBD	TBD	0
5		Reserved		RW	TBD	TBD	0
4		Reserved		RW	TBD	TBD	0
3		Reserved		RW	TBD	TBD	0
2		Reserved		RW	TBD	TBD	0
1		CPU 1 Stop Enable	Enables control of CPU1 with CPU_STOP#	RW	Free Running	Stoppable	1
0		CPU 0 Stop Enable	Enables control of CPU 0 with CPU_STOP#	RW	Free Running	Stoppable	1

Byte 11 CK505 Rev 1.0 functions (ICS Rev P silicon and higher)

Bit	Pin	Name	Description	Type	0	1	Default
7		Reserved	Reserved	RW	TBD	TBD	0
6		Reserved		RW	TBD	TBD	0
5		Reserved		RW	TBD	TBD	0
4		Reserved		RW	TBD	TBD	0
3		CPU2 iAMT_EN	Enables CPU2(ITP) output in iAMT state (M1)	RW	Off in iAMT	Free running in iAMT	0
2		CPU1 iAMT_EN	Enables CPU1 output in iAMT state (M1)	RW	Off in iAMT	Free running in iAMT	1
1		PCIe-Gen2	PCIe-Gen2 status	R	non-Gen2	PCIe Gen2 compliant	0
0		CPU2 Stop Enable	Enables control of CPU2(ITP) with CPU_STOP#	RW	Free Running	Stoppable	1

Byte 12 Byte Count Register

Bit	Pin	Name	Description	Type	0	1	Default	
7		Reserved	Read Back byte count register, max bytes = 32	RW			0	
6		Reserved		RW				0
5		BC5		RW				0
4		BC4		RW				0
3		BC3		RW				1
2		BC2		RW				1
1		BC1		RW				0
0		BC0		RW				1

Byte 13 CK505 PLL1 M/N Programming Register

Bit	Pin	Name	Description	Type	0	1	Default
7		N Div8	N Divider 8	RW	-	-	X
6		N Div9	N Divider 9	RW	-	-	X
5		M Div5	The decimal representation of M and N Divider in Byte 13 and 14 will configure the VCO frequency. Default at power up = latch-in or Byte 0 Rom table.	RW	-	-	X
4		M Div4		RW	-	-	X
3		M Div3		RW	-	-	X
2		M Div2		RW	-	-	X
1		M Div1		RW	-	-	X
				RW	-	-	X
0		M Div0		RW	-	-	X

Byte 14 CK505 PLL1 M/N Programming Register

Bit	Pin	Name	Description	Type	0	1	Default
7		N Div7	The decimal representation of M and N Divider in Byte 13 and 14 will configure the VCO frequency. Default at power up = latch-in or Byte 0 Rom table.	RW	-	-	X
6		N Div6		RW	-	-	X
5		N Div5		RW	-	-	X
4		N Div4		RW	-	-	X
3		N Div3		RW	-	-	X
2		N Div2		RW	-	-	X
1		N Div1		RW	-	-	X
0		N Div0		RW	-	-	X

Byte 15 CK505 PLL1 Spread Spectrum Control Register

Bit	Pin	Name	Description	Type	0	1	Default
7		SSP7	These Spread Spectrum bits will program the spread percentage. Contact ICS for the correct values.	RW	-	-	X
6		SSP6		RW	-	-	X
5		SSP5		RW	-	-	X
4		SSP4		RW	-	-	X
3		SSP3		RW	-	-	X
2		SSP2		RW	-	-	X
1		SSP1		RW	-	-	X
0		SSP0		RW	-	-	X

Byte 16 CK505 PLL1 Spread Spectrum Control Register

Bit	Pin	Name	Description	Type	0	1	Default
7		Reserved	Reserved	RW	-	-	0
6		SSP14	These Spread Spectrum bits will program the spread percentage. Contact ICS for the correct values.	RW	-	-	x
5		SSP13		RW	-	-	X
4		SSP12		RW	-	-	X
3		SSP11		RW	-	-	X
2		SSP10		RW	-	-	X
1		SSP9		RW	-	-	X
0		SSP8		RW	-	-	X

Byte 17 CK505 PLL3 M/N Programming Register

Bit	Pin	Name	Description	Type	0	1	Default
7		N Div8	N Divider 8	RW	-	-	X
6		N Div9	N Divider 9	RW	-	-	X
5		M Div5	The decimal representation of M and N Divider in Byte 17 and 18 will configure the VCO frequency. Default at power up = latch-in or Byte 0 Rom table.	RW	-	-	X
4		M Div4		RW	-	-	X
3		M Div3		RW	-	-	X
2		M Div2		RW	-	-	X
1		M Div1		RW	-	-	X
0		M Div0		RW	-	-	X

Byte 18 CK505 PLL3 M/N Programming Register

Bit	Pin	Name	Description	Type	0	1	Default
7		N Div7	The decimal representation of M and N Divider in Byte 17 and 18 will configure the VCO frequency. Default at power up = latch-in or Byte 0 Rom table.	RW	-	-	X
6		N Div6		RW	-	-	X
5		N Div5		RW	-	-	X
4		N Div4		RW	-	-	X
3		N Div3		RW	-	-	X
2		N Div2		RW	-	-	X
1		N Div1		RW	-	-	X
0		N Div0		RW	-	-	X

Byte 19 CK505 PLL3 Spread Spectrum Control Register

Bit	Pin	Name	Description	Type	0	1	Default
7		SSP7	These Spread Spectrum bits will program the spread percentage. Contact ICS for the correct values.	RW	-	-	X
6		SSP6		RW	-	-	X
5		SSP5		RW	-	-	X
4		SSP4		RW	-	-	X
3		SSP3		RW	-	-	X
2		SSP2		RW	-	-	X
1		SSP1		RW	-	-	X
0		SSP0		RW	-	-	X

Byte 20 CK505 PLL3 Spread Spectrum Control Register

Bit	Pin	Name	Description	Type	0	1	Default
7		Reserved	Reserved	RW	-	-	0
6		SSP14	These Spread Spectrum bits will program the spread percentage. Contact ICS for the correct values.	RW	-	-	X
5		SSP13		RW	-	-	X
4		SSP12		RW	-	-	X
3		SSP11		RW	-	-	X
2		SSP10		RW	-	-	X
1		SSP9		RW	-	-	X
0		SSP8		RW	-	-	X

Byte 21 M/N Enables

Bit	Pin	Name	Description	Type	0	1	Default
7		Reserved		RW			0
6		Reserved		RW			0
5		Reserved		RW			0
4		Reserved		RW			0
3		Reserved		RW			0
2		Reserved		RW			0
1		M/N Enable CPU		RW	Disable	Enable	0
0		M/N Enable		RW	Disable	Enable	0

Byte 22 CPU M/N Programming

Bit	Pin	Name	Description	Type	0	1	Default
7		N Div bit 8	PLL 1 M/N Programming	RW	-	-	X
6		N Div bit 9	(Intel PLL1 CPU)	RW	-	-	X
5		M Div Bit 5		RW	-	-	X
4		M Div Bit 4		RW	-	-	X
3		M Div Bit 3		RW	-	-	X
2		M Div Bit 2		RW	-	-	X
1		M Div Bit 1		RW	-	-	X
0		M Div Bit 0		RW	-	-	X

Byte 23 CPU M/N Programming

Bit	Pin	Name	Description	Type	0	1	Default
7		N Div bit 7	PLL 1 M/N Programming	RW	-	-	X
6		N Div bit 6	(Intel PLL1 CPU)	RW	-	-	X
5		N Div bit 5		RW	-	-	X
4		N Div bit 4		RW	-	-	X
3		N Div bit 3		RW	-	-	X
2		N Div bit 2		RW	-	-	X
1		N Div bit 1		RW	-	-	X
0		N Div Bit 0		RW	-	-	X

Bytes 24-62 Reserved

Byte 63 Special Power Management Features (Rev P Silicon and Higher)

Bit	Pin	Name	Description	RW	0	1	Default
7		Reserved		RW			0
6		Reserved		RW			0
5		Reserved		RW			0
4		Reserved		RW			0
3		Reserved		RW			0
2		Reserved		RW			0
1		SATA PLL	Power Management Feature	RW	off	on	Note
0		XTAL PD Control	Controls XTAL on/off in legacy PD	RW	off	on	1

Note: Default is "off" for Rev P Silicon and higher.

***Accessing any SMBus bytes not shown in the datasheet could result in incorrect clock functions.**

Test Clarification Table

Comments	HW		SW		OUTPUT
	FSLC/ TEST_SEL HW PIN	FSLB/ TEST_MOD E HW PIN	TEST ENTRY BIT B9b3	REF/N or HI-Z B9b4	
	<2.0V	X	0	0	NORMAL
Power-up w/ TEST_SEL = 1 to enter test mode Cycle power to disable test mode FSLC./TEST_SEL -->3-level latched input If power-up w/ V>2.0V then use TEST_SEL If power-up w/ V<2.0V then use FSLC FSLB/TEST_MODE -->low Vth input TEST_MODE is a real time input	>2.0V	0	X	0	HI-Z
	>2.0V	0	X	1	REF/N
	>2.0V	1	X	0	REF/N
	>2.0V	1	X	1	REF/N
If TEST_SEL HW pin is 0 during power-up, test mode can be invoked through B9b3. If test mode is invoked by B9b3, only B9b4 is used to select HI-Z or REF/N FSLB/TEST_Mode pin is not used. Cycle power to disable test mode, one shot control	<2.0V	X	1	0	HI-Z
	<2.0V	X	1	1	REF/N

B9b3: 1= ENTER TEST MODE, Default = 0 (NORMAL OPERATION)

B9b4: 1= REF/N, Default = 0 (HI-Z)

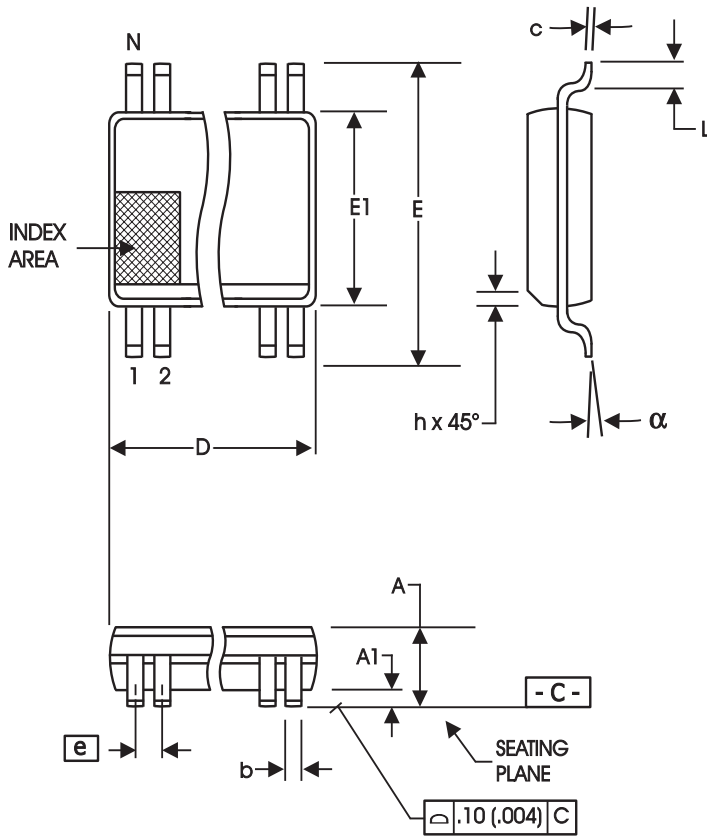

56-Lead, 300 mil Body, 25 mil, SSOP

SYMBOL	In Millimeters COMMON DIMENSIONS		In Inches COMMON DIMENSIONS	
	MIN	MAX	MIN	MAX
A	2.41	2.80	.095	.110
A1	0.20	0.40	.008	.016
b	0.20	0.34	.008	.0135
c	0.13	0.25	.005	.010
D	SEE VARIATIONS		SEE VARIATIONS	
E	10.03	10.68	.395	.420
E1	7.40	7.60	.291	.299
e	0.635 BASIC		0.025 BASIC	
h	0.38	0.64	.015	.025
L	0.50	1.02	.020	.040
N	SEE VARIATIONS		SEE VARIATIONS	
alpha	0°	8°	0°	8°

VARIATIONS

N	D mm.		D (inch)	
	MIN	MAX	MIN	MAX
56	18.31	18.55	.720	.730

Reference Doc.: JEDEC Publication 95, MO-118

10-0034

Ordering Information

9LPR502yFLFT

Example:

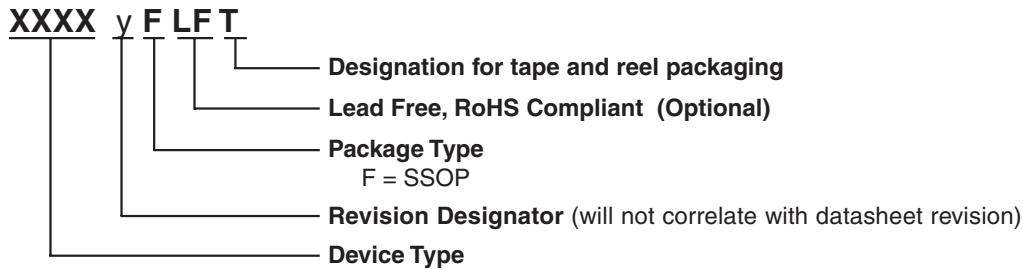

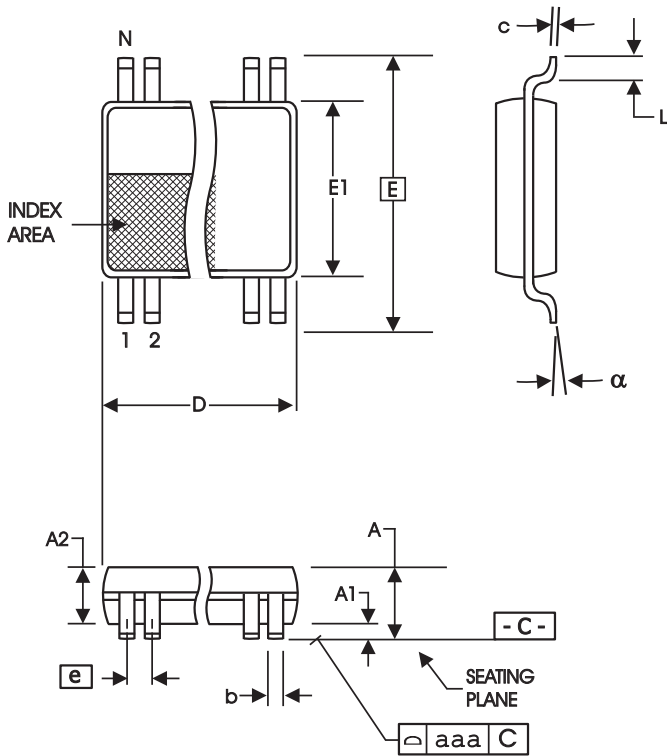

56-Lead 6.10 mm. Body, 0.50 mm. Pitch TSSOP
(240 mil) (20 mil)

SYMBOL	In Millimeters		In Inches	
	COMMON DIMENSIONS	COMMON DIMENSIONS	COMMON DIMENSIONS	COMMON DIMENSIONS
	MIN	MAX	MIN	MAX
A	--	1.20	--	.047
A1	0.05	0.15	.002	.006
A2	0.80	1.05	.032	.041
b	0.17	0.27	.007	.011
c	0.09	0.20	.0035	.008
D	SEE VARIATIONS		SEE VARIATIONS	
E	8.10 BASIC		0.319 BASIC	
E1	6.00	6.20	.236	.244
e	0.50 BASIC		0.020 BASIC	
L	0.45	0.75	.018	.030
N	SEE VARIATIONS		SEE VARIATIONS	
alpha	0°	8°	0°	8°
aaa	--	0.10	--	.004

VARIATIONS

N	D mm.		D (inch)	
	MIN	MAX	MIN	MAX
56	13.90	14.10	.547	.555

Reference Doc.: JEDEC Publication 95, MO-153

10-0039

Ordering Information

9LPR502yGLFT

Example:

XXXX **y** **G** **LFT**

Designation for tape and reel packaging

Lead Free, RoHS Compliant

Package Type
G = TSSOP

Revision Designator (will not correlate with datasheet revision)

Device Type

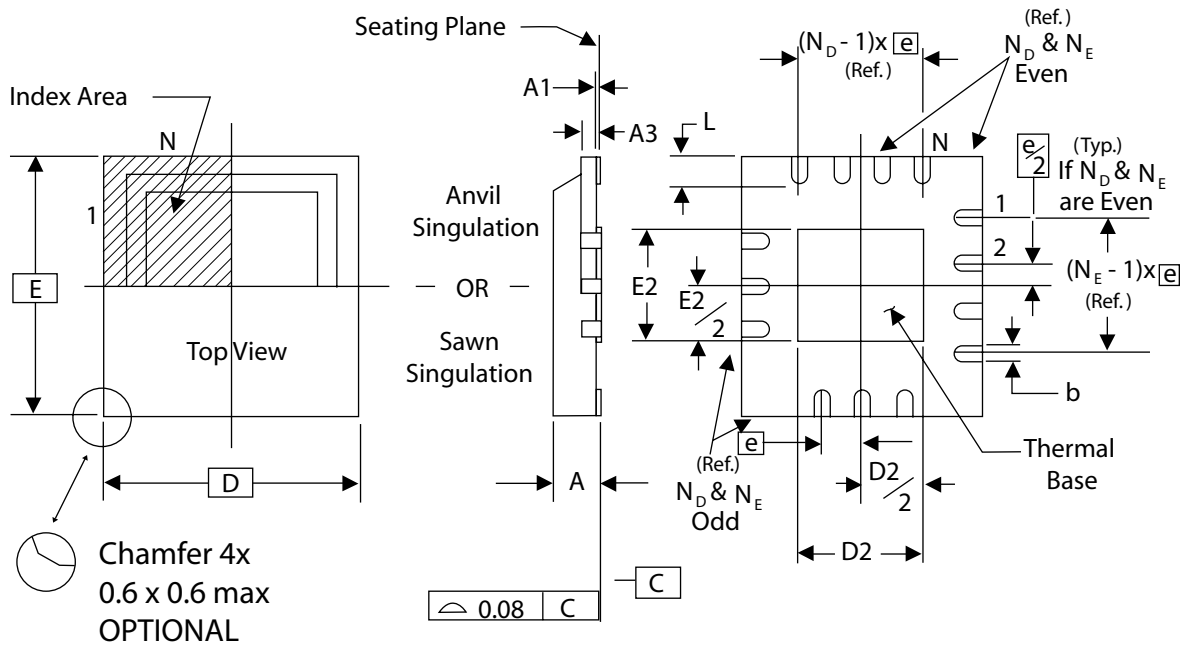

**THERMALLY ENHANCED, VERY THIN, FINE PITCH
QUAD FLAT / NO LEAD PLASTIC PACKAGE**

DIMENSIONS

SYMBOL	MIN.	MAX.
A	0.8	1.0
A1	0	0.05
A3	0.25 Reference	
b	0.18	0.3
e	0.50 BASIC	

DIMENSIONS

SYMBOL	ICS 56L TOLERANCE
N	56
N_D	14
N_E	14
D x E BASIC	8.00 x 8.00
D2 MIN. / MAX.	4.35 / 4.65
E2 MIN. / MAX.	5.05 / 5.35
L MIN. / MAX.	0.30 / 0.50

Ordering Information

9LPR502yKLFT

Example:

XXXX y K LFT

- Designation for tape and reel packaging
- Lead Free, RoHS Compliant
- Package Type
K = MLF
- Revision Designator (will not correlate with datasheet revision)
- Device Type

Revision History

Rev.	Issue Date	Description	Page #
A	2/19/2008	1. Updated Table 3: PLL3 Configuration. 2. Release to Final.	16
B	2/9/2009	1. Updated Electrical tables	Various
C	2/23/2009	Updated note under Byte 63 Table.	24
D	2/26/2009	Updated Byte 8 Table.	21

IMPORTANT NOTICE AND DISCLAIMER

RENESAS ELECTRONICS CORPORATION AND ITS SUBSIDIARIES (“RENESAS”) PROVIDES TECHNICAL SPECIFICATIONS AND RELIABILITY DATA (INCLUDING DATASHEETS), DESIGN RESOURCES (INCLUDING REFERENCE DESIGNS), APPLICATION OR OTHER DESIGN ADVICE, WEB TOOLS, SAFETY INFORMATION, AND OTHER RESOURCES “AS IS” AND WITH ALL FAULTS, AND DISCLAIMS ALL WARRANTIES, EXPRESS OR IMPLIED, INCLUDING, WITHOUT LIMITATION, ANY IMPLIED WARRANTIES OF MERCHANTABILITY, FITNESS FOR A PARTICULAR PURPOSE, OR NON-INFRINGEMENT OF THIRD-PARTY INTELLECTUAL PROPERTY RIGHTS.

These resources are intended for developers who are designing with Renesas products. You are solely responsible for (1) selecting the appropriate products for your application, (2) designing, validating, and testing your application, and (3) ensuring your application meets applicable standards, and any other safety, security, or other requirements. These resources are subject to change without notice. Renesas grants you permission to use these resources only to develop an application that uses Renesas products. Other reproduction or use of these resources is strictly prohibited. No license is granted to any other Renesas intellectual property or to any third-party intellectual property. Renesas disclaims responsibility for, and you will fully indemnify Renesas and its representatives against, any claims, damages, costs, losses, or liabilities arising from your use of these resources. Renesas' products are provided only subject to Renesas' Terms and Conditions of Sale or other applicable terms agreed to in writing. No use of any Renesas resources expands or otherwise alters any applicable warranties or warranty disclaimers for these products.

(Disclaimer Rev.1.01 Jan 2024)

Corporate Headquarters

TOYOSU FORESIA, 3-2-24 Toyosu,
Koto-ku, Tokyo 135-0061, Japan
www.renesas.com

Trademarks

Renesas and the Renesas logo are trademarks of Renesas Electronics Corporation. All trademarks and registered trademarks are the property of their respective owners.

Contact Information

For further information on a product, technology, the most up-to-date version of a document, or your nearest sales office, please visit www.renesas.com/contact-us/.