

### Recommended Application:

Poulsbo Based Ultra-Mobile PC (UMPC) - CK610

### Output Features:

- 3 - CPU low power differential push-pull pairss
- 3 - SRC low power differential push-pull pairs
- 1 - LCD100 SSCD low power differential push-pull pair
- 1 - DOT96 low power differential push-pull pair
- 1 - REF, 14.31818MHz, 3.3V SE output

### Features/Benefits:

- Supports Dothan ULV CPUs with 100 to 200 MHz CPU outputs
- Dedicated TEST/SEL and TEST/MODE pins saves isolation resistors on pins
- CPU STOP# input for power managment
- Fully integrated Vreg
- Integrated series resistors on differential outputs
- 1.5V VDD IO, 1.5V VDD core, 3.3V VDD supply pin for REF

### Pin Configuration

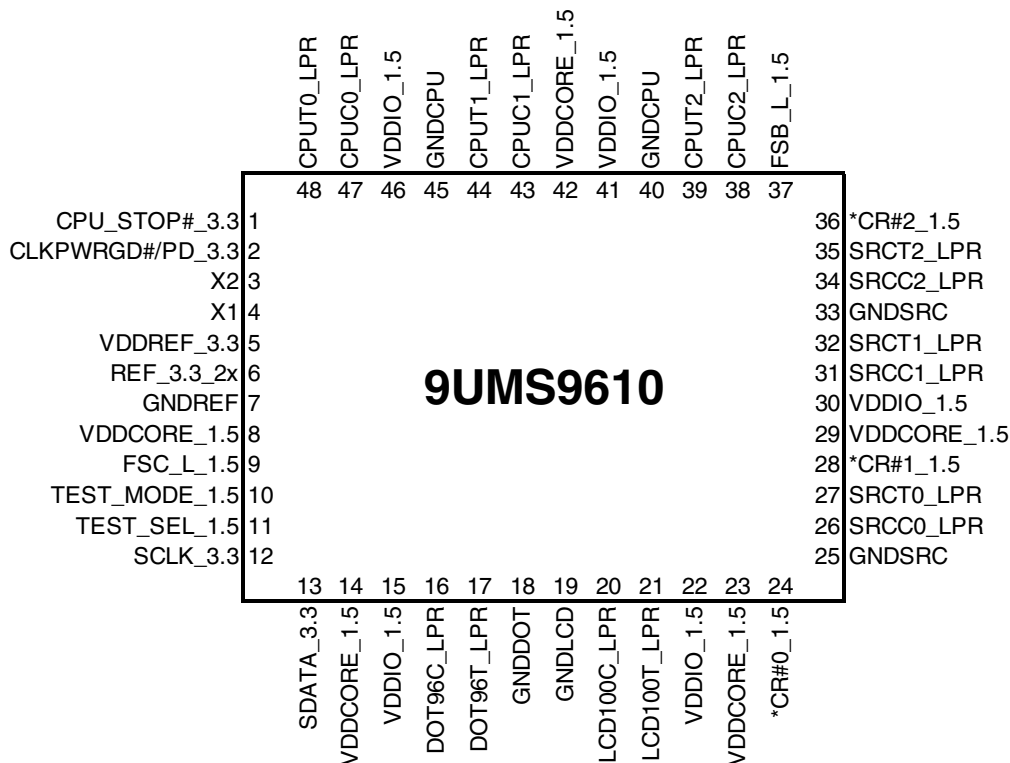

**48-pin MLF, 6x6 mm, 0.4mm pitch**

\* indicates inputs with internal pull up of ~10Kohm to 1.5V

## Pin Description

PIN #	PIN NAME	TYPE	DESCRIPTION	Logic Level (V)	Input Level Tolerance (V)
1	CPU_STOP#_3.3	IN	This active-low input stops all CPU clocks that are set to be stoppable.	3.3	3.3
2	CLKPWRGD#/PD_3.3	IN	This level sensitive strobe determines when latch inputs are valid and are ready to be sampled. When high, this asynchronous input places the device into the power down state.	3.3	3.3
3	X2	OUT	Crystal output, Nominally 14.318MHz	N/A	N/A
4	X1	IN	Crystal input, Nominally 14.318MHz.	1.5	1.5
5	VDDREF_3.3	PWR	Power pin for the XTAL and REF clocks, nominal 3.3V	3.3	3.3
6	REF_3.3_2x	OUT	3.3V 14.318 MHz reference clock. Default 2 load drive strength	3.3	N/A
7	GNDREF	GND	Ground pin for the REF outputs.	0	N/A
8	VDDCORE_1.5	PWR	1.5V power for the PLL core	1.5	1.5
9	FSC_L_1.5	IN	Low threshold input for CPU frequency selection. Refer to input electrical characteristics for Vil_FS and Vih_FS values. 1.5V Max input voltage.	1.5	1.5
10	TEST_MODE_1.5	IN	TEST_MODE is a real time input to select between Hi-Z and REF/N divider mode while in test mode. Refer to Test Clarification Table. Max input voltage is 1.5V.	1.5	3.3
11	TEST_SEL_1.5	IN	TEST_SEL: latched input to select TEST MODE. Max input voltage is 1.5V 1 = All outputs are tri-stated for test 0 = All outputs behave normally.	1.5	3.3
12	SCLK_3.3	IN	Clock pin of SMBus circuitry, 3.3V tolerant.	3.3	3.3
13	SDATA_3.3	I/O	Data pin for SMBus circuitry, 3.3V tolerant.	3.3	3.3
14	VDDCORE_1.5	PWR	1.5V power for the PLL core	1.5	1.5
15	VDDIO_1.5	PWR	Power supply for low power differential outputs, nominal 1.5V.	1.5	1.5
16	DOT96C_LPR	OUT	Complement clock of low power differential pair for 96.00MHz DOT clock. No 50ohm resistor to GND needed. No Rs needed.	0.8	N/A
17	DOT96T_LPR	OUT	True clock of low power differential pair for 96.00MHz DOT clock. No 50ohm resistor to GND needed. No Rs needed.	0.8	N/A
18	GNDDOT	GND	Ground pin for DOT clock output	0	N/A
19	GNDLCD	GND	Ground pin for LCD clock output	0	N/A
20	LCD100C_LPR	OUT	Complement clock of low power differential pair for LCD100 SS clock. No 50ohm resistor to GND needed. No Rs needed.	0.8	N/A
21	LCD100T_LPR	OUT	True clock of low power differential pair for LCD100 SS clock. No 50ohm resistor to GND needed. No Rs needed.	0.8	N/A
22	VDDIO_1.5	PWR	Power supply for low power differential outputs, nominal 1.5V.	1.5	1.5
23	VDDCORE_1.5	PWR	1.5V power for the PLL core	1.5	1.5
24	*CR#0_1.5	IN	1.5V Clock request for SRC0, 0 = enable, 1 = disable	1.5	1.5

## Pin Description (continued)

PIN #	PIN NAME	TYPE	DESCRIPTION	Logic Level (V)	Input Level Tolerance (V)
25	GNDSRC	GND	Ground pin for the SRC outputs	0	N/A
26	SRCC0_LPR	OUT	Complementary clock of differential 0.8V push-pull SRC output with integrated 33ohm series resistor. No 50ohm resistor to GND needed.	0.8	N/A
27	SRCT0_LPR	OUT	True clock of differential 0.8V push-pull SRC output with integrated 33ohm series resistor. No 50ohm resistor to GND needed.	0.8	N/A
28	*CR#1_1.5	IN	1.5V Clock request for SRC1, 0 = enable, 1 = disable	1.5	1.5
29	VDDCORE_1.5	PWR	1.5V power for the PLL core	1.5	1.5
30	VDDIO_1.5	PWR	Power supply for low power differential outputs, nominal 1.5V.	1.5	1.5
31	SRCC1_LPR	OUT	Complementary clock of differential 0.8V push-pull SRC output with integrated 33ohm series resistor. No 50ohm resistor to GND needed.	0.8	N/A
32	SRCT1_LPR	OUT	True clock of differential 0.8V push-pull SRC output with integrated 33ohm series resistor. No 50ohm resistor to GND needed.	0.8	N/A
33	GNDSRC	GND	Ground pin for the SRC outputs	0	N/A
34	SRCC2_LPR	OUT	Complementary clock of differential 0.8V push-pull SRC output with integrated 33ohm series resistor. No 50ohm resistor to GND needed.	0.8	N/A
35	SRCT2_LPR	OUT	True clock of differential 0.8V push-pull SRC output with integrated 33ohm series resistor. No 50ohm resistor to GND needed.	0.8	N/A
36	*CR#2_1.5	IN	1.5V Clock request for SRC2, 0 = enable, 1 = disable	1.5	1.5
37	FSB_L_1.5	IN	Low threshold input for CPU frequency selection. Refer to input electrical characteristics for $V_{il\_FS}$ and $V_{ih\_FS}$ values. 1.5V Max input voltage.	1.5	1.5
38	CPUC2_LPR	OUT	Complementary clock of differential pair 0.8V push-pull CPU outputs with integrated 33ohm series resistor. No 50 ohm resistor to GND needed.	0.8	N/A
39	CPUT2_LPR	OUT	True clock of differential pair 0.8V push-pull CPU outputs with integrated 33ohm series resistor. No 50 ohm resistor to GND needed.	0.8	N/A
40	GNDCPU	GND	Ground pin for the CPU outputs	0	N/A
41	VDDIO_1.5	PWR	Power supply for low power differential outputs, nominal 1.5V.	1.5	1.5
42	VDDCORE_1.5	PWR	1.5V power for the PLL core	1.5	1.5
43	CPUC1_LPR	OUT	Complementary clock of differential pair 0.8V push-pull CPU outputs with integrated 33ohm series resistor. No 50 ohm resistor to GND needed.	0.8	N/A
44	CPUT1_LPR	OUT	True clock of differential pair 0.8V push-pull CPU outputs with integrated 33ohm series resistor. No 50 ohm resistor to GND needed.	0.8	N/A
45	GNDCPU	GND	Ground pin for the CPU outputs	0	N/A
46	VDDIO_1.5	PWR	Power supply for low power differential outputs, nominal 1.5V.	1.5	1.5
47	CPUC0_LPR	OUT	Complementary clock of differential pair 0.8V push-pull CPU outputs with integrated 33ohm series resistor. No 50 ohm resistor to GND needed.	0.8	N/A
48	CPUT0_LPR	OUT	True clock of differential pair 0.8V push-pull CPU outputs with integrated 33ohm series resistor. No 50 ohm resistor to GND needed.	0.8	N/A

## Functional Block Diagram

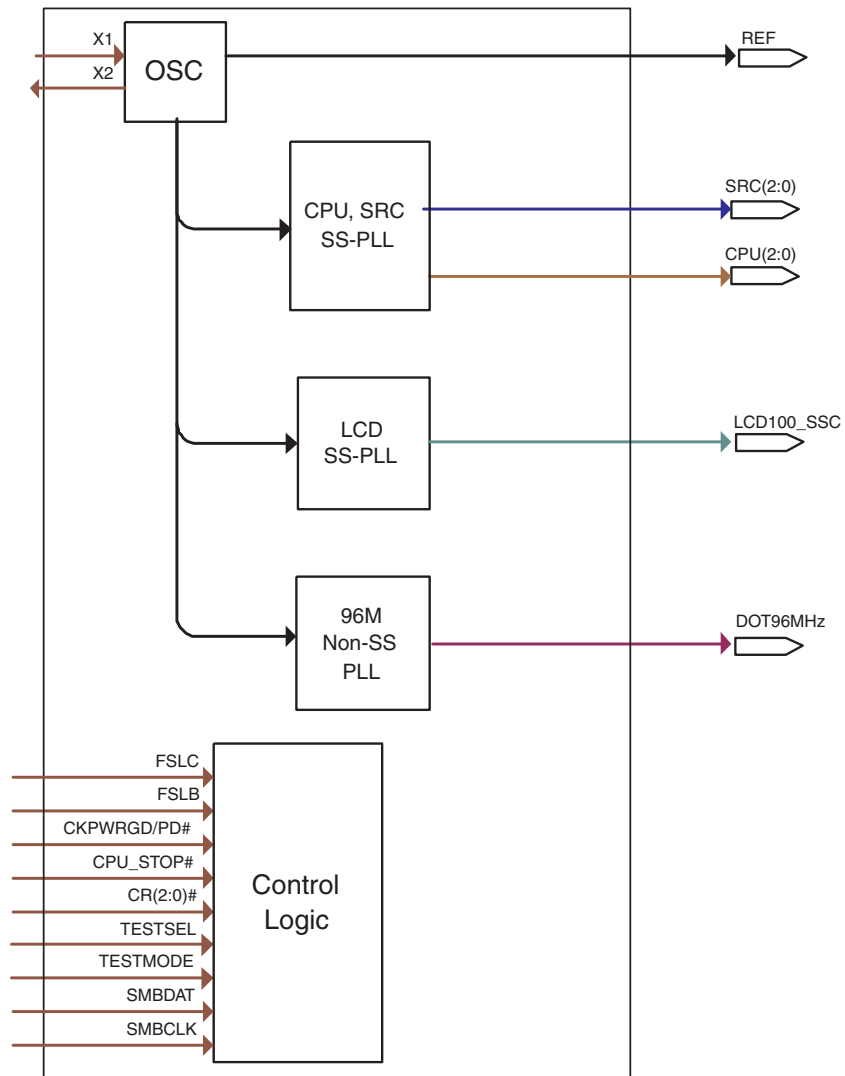

## Power Groups

Pin Number		Description	
VDD	GND		
41, 46	40, 45	CPUCLK	Low power outputs
42			VDDCORE_1.5V
30	25, 33	SRCCLK	Low power outputs
29			VDDCORE_1.5V
22	19	LCDCLK	Low power outputs
23			VDDCORE_1.5V
15	18	DOT 96Mhz	Low power outputs
14			VDDCORE_1.5V
5	7	Xtal, REF	

## Absolute Maximum Ratings

PARAMETER	SYMBOL	CONDITIONS	MIN	MAX	UNITS	Notes
3.3V Supply Voltage	VDDxxx_3.3	Supply Voltage		3.9	V	1,2
1.5V Supply Voltage	VDDxxx_1.5	Supply Voltage		2.1	V	1,2
3.3_Input High Voltage	V <sub>IH3.3</sub>	3.3V Inputs		VDD_3.3+ 0.3V	V	1,2,3
1.5_Input High Voltage	V <sub>IH1.5</sub>	1.5V Inputs		VDD_1.5+ 0.3V	V	1,2,3
Minimum Input Voltage	V <sub>IL</sub>	Any Input	GND - 0.5		V	1
Storage Temperature	T <sub>s</sub>	-	-65	150	°C	1,2
Input ESD protection	ESD prot	Human Body Model	2000		V	1,2

### Notes:

<sup>1</sup>Guaranteed by design and characterization, not 100% tested in production.

<sup>2</sup>Operation under these conditions is neither implied, nor guaranteed.

<sup>3</sup>Maximum input voltage is not to exceed maximum VDD

## Electrical Characteristics - Input/Supply/Common Output Parameters

PARAMETER	SYMBOL	CONDITIONS	MIN	MAX	UNITS	Notes
Ambient Operating Temp	T <sub>ambient</sub>	No Airflow	0	85	°C	1
3.3V Supply Voltage	VDDxxx_3.3	3.3V +/- 5%	3.135	3.465	V	1
1.5V Supply Voltage	VDDxxx_1.5	1.5V +/- 5%	1.425	1.575	V	1
3.3V Input High Voltage	V <sub>IHSE3.3</sub>	Single-ended inputs	2	V <sub>DDxx_3.3</sub> + 0.3	V	1
3.3V Input Low Voltage	V <sub>ILSE3.3</sub>	Single-ended inputs	V <sub>SS</sub> - 0.3	0.8	V	1
1.5V Input High Voltage	V <sub>IHSE1.5</sub>	Single-ended inputs	1.2	V <sub>DDxx_1.5</sub> + 0.3	V	1
1.5V Input Low Voltage	V <sub>ILSE1.5</sub>	Single-ended inputs	V <sub>SS</sub> - 0.3	0.3	V	1
Input Leakage Current	I <sub>IN</sub>	V <sub>IN</sub> = V <sub>DD</sub> , V <sub>IN</sub> = GND	-5	5	uA	1
Input Leakage Current	I <sub>INRES</sub>	Inputs with pull or pull down resistors V <sub>IN</sub> = V <sub>DD</sub> , V <sub>IN</sub> = GND	-200	200	uA	1
Output High Voltage	V <sub>OHSSE</sub>	Single-ended output, I <sub>OH</sub> = -1mA	2.4		V	1
Output Low Voltage	V <sub>OLSSE</sub>	Single-ended output, I <sub>OL</sub> = 1 mA		0.4	V	1
Low Threshold Input-High Voltage	V <sub>IH_FS</sub>	1.5 V +/-5%	0.7	1.5	V	1
Low Threshold Input-Low Voltage	V <sub>IL_FS</sub>	1.5 V +/-5%	V <sub>SS</sub> - 0.3	0.35	V	1
Operating Supply Current	I <sub>DD_3.3</sub>	3.3V supply		10	mA	1
	I <sub>DD_DEFAULT1.5</sub>	1.5V core supply, LCDPLL off		45	mA	1
	I <sub>DD_LCDEN1.5</sub>	1.5V core supply, LCDPLL enabled		55	mA	1
	I <sub>DD_IO1.5</sub>	1.5V supply, Differential IO current, all outputs enabled		15	mA	1
Power Down Current	I <sub>DD_PD3.3</sub>	3.3V supply, Power Down Mode		0.5	mA	1
	I <sub>DD_PD1.5CORE</sub>	1.5V CORE supply, Power Down Mode		0.5	mA	1
	I <sub>DD_PD1.5IO</sub>	1.5V IO supply, Power Down Mode		0.1	mA	1
Input Frequency	F <sub>i</sub>	V <sub>DD</sub> = 3.3 V		15	MHz	2
Pin Inductance	L <sub>pin</sub>			7	nH	1
Input Capacitance	C <sub>IN</sub>	Logic Inputs	1.5	5	pF	1
	C <sub>OUT</sub>	Output pin capacitance		6	pF	1
	C <sub>INX</sub>	X1 & X2 pins	3	5	pF	1
Spread Spectrum Modulation Frequency	f <sub>SSMOD</sub>	Triangular Modulation	30	33	kHz	1

### AC Electrical Characteristics - Input/Common Parameters

PARAMETER	SYMBOL	CONDITIONS	MIN	MAX	UNITS	Notes
Clk Stabilization	$T_{STAB}$	From VDD Power-Up or de-assertion of PD# to 1st clock		1.8	ms	1
Tdrive_PD#	$T_{DRPD}$	Differential output enable after PD# de-assertion		300	us	1
Tdrive_CPU	$T_{DRSRC}$	CPU output enable after CPU_STOP# de-assertion	2	6	Cycles	1
Tfall_PD#	$T_{FALL}$	Fall/rise time of PD# and CPU_STOP# inputs		5	ns	1
Trise_PD#	$T_{RISE}$			5	ns	1

### AC Electrical Characteristics - Low Power Differential Outputs

PARAMETER	SYMBOL	CONDITIONS	MIN	MAX	UNITS	NOTES
Rising Edge Slew Rate	$t_{SLR}$	Differential Measurement	0.6	4	V/ns	1,2
Falling Edge Slew Rate	$t_{FLR}$	Differential Measurement	0.6	4	V/ns	1,2
Rise/Fall Time Variation	$t_{SLVAR}$	Single-ended Measurement		125	ps	1
Maximum Output Voltage	$V_{HIGH}$	Includes overshoot		1150	mV	1
Minimum Output Voltage	$V_{LOW}$	Includes undershoot	-300		mV	1
Differential Voltage Swing	$V_{SWING}$	Differential Measurement	300		mV	1
Crossing Point Voltage	$V_{XABS}$	Single-ended Measurement	300	550	mV	1,3,4
Crossing Point Variation	$V_{XABSVAR}$	Single-ended Measurement		140	mV	1,3,5
Duty Cycle	$D_{CYC}$	Differential Measurement	45	55	%	1
CPU Jitter - Cycle to Cycle	$CPUJ_{C2C}$	Differential Measurement		85	ps	1
SRC Jitter - Cycle to Cycle	$SRCJ_{C2C}$	Differential Measurement		125	ps	1
DOT Jitter - Cycle to Cycle	$DOTJ_{C2C}$	Differential Measurement		250	ps	1
LCD Jitter - Cycle to Cycle	$LCDJ_{C2C}$	Differential Measurement		85	ps	1
CPU[2:0] Skew	$CPU_{SKEW10}$	Differential Measurement		100	ps	1
SRC[2:0] Skew	$SRC_{SKEW}$	Differential Measurement		250	ps	1

### Electrical Characteristics - REF-14.318MHz

PARAMETER	SYMBOL	CONDITIONS	MIN	MAX	UNITS	Notes
Long Accuracy	ppm	see Tperiod min-max values	-300	300	ppm	1,2
Clock period	$T_{period}$	14.318MHz output nominal	69.8203	69.8622	ns	2
Absolute min/max period	$T_{abs}$	14.318MHz output nominal	69.8203	70.86224	ns	2
Output High Voltage	$V_{OH}$	$I_{OH} = -1$ mA	2.4		V	1
Output Low Voltage	$V_{OL}$	$I_{OL} = 1$ mA		0.4	V	1
Output High Current	$I_{OH}$	$V_{OH} @ MIN = 1.0$ V, $V_{OH} @ MAX = 3.135$ V	-33	-33	mA	1
Output Low Current	$I_{OL}$	$V_{OL} @ MIN = 1.95$ V, $V_{OL} @ MAX = 0.4$ V	30	38	mA	1
Rising Edge Slew Rate	$t_{SLR}$	Measured from 0.8 to 2.0 V	1	4	V/ns	1
Falling Edge Slew Rate	$t_{FLR}$	Measured from 2.0 to 0.8 V	1	4	V/ns	1
Duty Cycle	$d_{11}$	$V_T = 1.5$ V	45	55	%	1
Jitter	$t_{jycyc-cyc}$	$V_T = 1.5$ V		1000	ps	1

## Electrical Characteristics - SMBus Interface

PARAMETER	SYMBOL	CONDITIONS	MIN	MAX	UNITS	Notes
SMBus Voltage	$V_{DD}$		2.7	3.6	V	1
Low-level Output Voltage	$V_{OLSMB}$	@ $I_{PULLUP}$		0.4	V	1
Current sinking at $V_{OLSMB} = 0.4\text{ V}$	$I_{PULLUP}$	SMB Data Pin	4		mA	1
SCLK/SDATA Clock/Data Rise Time	$T_{RI2C}$	(Max $V_{IL} - 0.15$ ) to (Min $V_{IH} + 0.15$ )		1000	ns	1
SCLK/SDATA Clock/Data Fall Time	$T_{FI2C}$	(Min $V_{IH} + 0.15$ ) to (Max $V_{IL} - 0.15$ )		300	ns	1
Maximum SMBus Operating Frequency	$F_{SMBUS}$	Block Mode		100	kHz	1

### Notes on Electrical Characteristics:

- <sup>1</sup>Guaranteed by design and characterization, not 100% tested in production.
- <sup>2</sup>Slew rate measured through  $V_{swing}$  centered around differential zero
- <sup>3</sup> $V_{xabs}$  is defined as the voltage where  $CLK = CLK\#$
- <sup>4</sup>Only applies to the differential rising edge (CLK rising and CLK# falling)
- <sup>5</sup>Defined as the total variation of all crossing voltages of CLK rising and CLK# falling. Matching applies to rising edge rate of CLK and falling edge of CLK#. It is measured using a +/-75mV window centered on the average cross point where CLK meets CLK#. The average cross point is used to calculate the voltage thresholds the oscilloscope is to use for the edge rate calculations.
- <sup>6</sup>All Long Term Accuracy and Clock Period specifications are guaranteed assuming that REF is at 14.31818MHz
- <sup>7</sup>Operation under these conditions is neither implied, nor guaranteed.
- <sup>8</sup>Maximum input voltage is not to exceed maximum VDD
- <sup>9</sup>See PCI Clock-to-Clock Delay Figure

## Clock Periods Differential Outputs with Spread Spectrum Enabled

Measurement Window	1 Clock	1us	0.1s	0.1s	0.1s	1us	1 Clock			
Symbol	Lg-	-SSC	-ppm error	0ppm	+ ppm error	+SSC	Lg+			
Definition	Absolute Period	Short-term Average	Long-Term Average	Period	Long-Term Average	Short-term Average	Period	Units	Notes	
	Minimum Absolute Period	Minimum Absolute Period	Minimum Absolute Period	Nominal	Maximum	Maximum	Maximum			
Signal Name	SRC 100	9.87400	9.99900	9.99900	10.00000	10.00100	10.05130	10.17630	ns	1,2
	CPU 100	9.91400	9.99900	9.99900	10.00000	10.00100	10.05130	10.13630	ns	1,2
	CPU 133	7.41425	7.49925	7.49925	7.50000	7.50075	7.53845	7.62345	ns	1,2

## Clock Periods Differential Outputs with Spread Spectrum Disabled

Measurement Window	1 Clock	1us	0.1s	0.1s	0.1s	1us	1 Clock			
Symbol	Lg-	-SSC	-ppm error	0ppm	+ ppm error	+SSC	Lg+			
Definition	Absolute Period	Short-term Average	Long-Term Average	Period	Long-Term Average	Short-term Average	Period	Units	Notes	
	Minimum Absolute Period	Minimum Absolute Period	Minimum Absolute Period	Nominal	Maximum	Maximum	Maximum			
Signal Name	SRC 100	9.87400		9.99900	10.00000	10.00100		10.17630	ns	1,2
	CPU 100	9.91400		9.99900	10.00000	10.00100		10.13630	ns	1,2
	CPU 133	7.41425		7.49925	7.50000	7.50075		7.62345	ns	1,2
	DOT 96	10.16560		10.41560	10.41670	10.41770		10.66770	ns	1,2

<sup>1</sup>Guaranteed by design and characterization, not 100% tested in production.

<sup>2</sup>All Long Term Accuracy and Clock Period specifications are guaranteed assuming that REFOUT is at 14.31818MHz

**Table 1: CPU Frequency Select Table**

FS <sub>L</sub> C <sup>1</sup>	FS <sub>L</sub> B <sup>1</sup>	CPU MHz	SRC MHz	DOT MHz	LCD100 MHz	REF MHz
0	0	133.33	100.00	96.00	100.00	14.318
0	1	166.67				
1	0	100.00				
1	1	200.00				

1. FS<sub>L</sub>C is a low-threshold input. Please see V<sub>IL\_FS</sub> and V<sub>IH\_FS</sub> specifications in the Input/Supply/Common Output Parameters Table for correct values. Also refer to the Test Clarification Table.

**Table 2: LCD Spread Select Table (Pin 20/21)**

B1b5	B1b4	B1b3	Spread %	Comment
0	0	0	-0.5%	LCD100
0	0	1	-1%	LCD100
0	1	0	-2%	LCD100
0	1	1	-2.5%	LCD100
1	0	0	+/- 0.25%	LCD100
1	0	1	+/-0.5%	LCD100
1	1	0	+/-1%	LCD100
1	1	1	+/-1.25%	LCD100



## General I<sup>2</sup>C serial interface information for the ICS9UMS9610

### How to Write:

- Controller (host) sends a start bit.
- Controller (host) sends the write address D2<sub>(H)</sub>
- ICS clock will **acknowledge**
- Controller (host) sends the beginning byte location = N
- ICS clock will **acknowledge**
- Controller (host) sends the data byte count = X
- ICS clock will **acknowledge**
- Controller (host) starts sending **Byte N through Byte N + X - 1**
- ICS clock will **acknowledge** each byte **one at a time**
- Controller (host) sends a Stop bit

Index Block Write Operation		
Controller (Host)		ICS (Slave/Receiver)
T	starT bit	
Slave Address D2 <sub>(H)</sub>		
WR	WRite	
		ACK
Beginning Byte = N		
		ACK
Data Byte Count = X		
		ACK
Beginning Byte N		X Byte
○		
○		
○		
Byte N + X - 1		
		ACK
P	stoP bit	

### How to Read:

- Controller (host) will send start bit.
- Controller (host) sends the write address D2<sub>(H)</sub>
- ICS clock will **acknowledge**
- Controller (host) sends the beginning byte location = N
- ICS clock will **acknowledge**
- Controller (host) will send a separate start bit.
- Controller (host) sends the read address D3<sub>(H)</sub>
- ICS clock will **acknowledge**
- ICS clock will send the data byte count = X
- ICS clock sends **Byte N + X - 1**
- ICS clock sends **Byte 0 through byte X (if X<sub>(H)</sub> was written to byte 8).**
- Controller (host) will need to acknowledge each byte
- Controller (host) will send a not acknowledge bit
- Controller (host) will send a stop bit

Index Block Read Operation		
Controller (Host)		ICS (Slave/Receiver)
T	starT bit	
Slave Address D2 <sub>(H)</sub>		
WR	WRite	
		ACK
Beginning Byte = N		
		ACK
RT	Repeat starT	
Slave Address D3 <sub>(H)</sub>		
RD	ReaD	
		ACK
		Data Byte Count = X
ACK		
		X Byte
Beginning Byte N		
○		
○		
○		
		Byte N + X - 1
N	Not acknowledge	
P	stoP bit	

Byte 0 PLL & Divider Enable Register

Bit(s)	Pin #	Name	Description	Type	0	1	Default
7	-	PLL1 Enable	This bit controls whether the PLL driving the CPU and SRC clocks is enabled or not.	RW	0 = Disabled	1 = Enabled	1
6	-	PLL2 Enable	This bit controls whether the PLL driving the DOT and clock is enabled or not.	RW	0 = Disabled	1 = Enabled	1
5	-	PLL3 Enable	This bit controls whether the PLL driving the LCD clock is enabled or not.	RW	0 = Disabled	1 = Enabled	1
4	-	Reserved					0
3	-	CPU Divider Enable	This bit controls whether the CPU output divider is enabled or not. <b>NOTE:</b> This bit should be automatically set to '0' if bit 7 is set to '0'.	RW	0 = Disabled	1 = Enabled	1
2	-	SRC Output Divider Enable	This bit controls whether the SRC output divider is enabled or not. <b>NOTE:</b> This bit should be automatically set to '0' if bit 7 is set to '0'.	RW	0 = Disabled	1 = Enabled	1
1	-	LCD Output Divider Enable	This bit controls whether the LCD output divider is enabled or not. <b>NOTE:</b> This bit should be automatically set to '0' if bit 5 is set to '0'.	RW	0 = Disabled	1 = Enabled	1
0	-	DOT Output Divider Enable	This bit controls whether the DOT output divider is enabled or not. <b>NOTE:</b> This bit should be automatically set to '0' if bit 6 is set to '0'.	RW	0 = Disabled	1 = Enabled	1

Byte 1 PLL SS Enable/Control Register

Bit(s)	Pin #	Name	Description	Type	0	1	Default
7		PLL1 SS Enable	This bit controls whether PLL1 has spread enabled or not. Spread spectrum for PLL1 is set at -0.5% down-spread. Note that PLL1 drives the CPU and SRC clocks.	RW	0 = Disabled	1 = Enabled	1
6		PLL3 SS Enable	This bit controls whether PLL3 has spread enabled or not. Note that PLL3 drives the SSC clock, and that the spread spectrum amount is set in bits 3-5.	RW	0 = Disabled	1 = Enabled	1
5		PLL3 FS Select	These 3 bits select the frequency of PLL3 and the SSC clock when Byte 1 Bit 6 (PLL3 Spread Spectrum Enable) is set.	RW	See Table 2: LCD Spread Select Table		0
4	0						
3	0						
2		Reserved					0
1		Reserved					0
0		Reserved					0

Byte 2 Output Enable Register

Bit(s)	Pin #	Name	Description	Type	0	1	Default
7		CPU0 Enable	This bit controls whether the CPU[0] output buffer is enabled or not.	RW	0 = Disabled	1 = Enabled	1
6		CPU1 Enable	This bit controls whether the CPU[1] output buffer is enabled or not.	RW	0 = Disabled	1 = Enabled	1
5		CPU2 Enable	This bit controls whether the CPU[2] output buffer is enabled or not.	RW	0 = Disabled	1 = Enabled	1
4		SRC0 Enable	This bit controls whether the SRC[0] output buffer is enabled or not.	RW	0 = Disabled	1 = Enabled	1
3		SRC1 Enable	This bit controls whether the SRC[1] output buffer is enabled or not.	RW	0 = Disabled	1 = Enabled	1
2		SRC2 Enable	This bit controls whether the SRC[2] output buffer is enabled or not.	RW	0 = Disabled	1 = Enabled	1
1		DOT Enable	This bit controls whether the DOT output buffer is enabled or not.	RW	0 = Disabled	1 = Enabled	1
0		LCD100 Enable	This bit controls whether the LCD output buffer is enabled or not.	RW	0 = Disabled	1 = Enabled	1

Byte 3 Output Control Register

Bit(s)	Pin #	Name	Description	Type	0	1	Default
7		Reserved					0
6		Reserved					0
5		REF Enable	This bit controls whether the REF output buffer is enabled or not.	RW	0 = Disabled	1 = Enabled	1
4		REF Slew	These bits control the edge rate of the REF clock.	RW	00 = Slow Edge Rate 01 = Medium Edge Rate 10 = Fast Edge Rate 11 = Reserved		10
3							
2		CPU0 Stop Enable	This bit controls whether the CPU[0] output buffer is free-running or stoppable. If it is set to stoppable the CPU[0] output buffer will be disabled with the assertion of CPU_STP#.	RW	Free Running	Stoppable	0
1		CPU1 Stop Enable	This bit controls whether the CPU[1] output buffer is free-running or stoppable. If it is set to stoppable the CPU[1] output buffer will be disabled with the assertion of CPU_STP#.	RW	Free Running	Stoppable	0
0		CPU2 Stop Enable	This bit controls whether the CPU[2] output buffer is free-running or stoppable. If it is set to stoppable the CPU[2] output buffer will be disabled with the assertion of CPU_STP#.	RW	Free Running	Stoppable	0

Byte 4 CPU PLL M/N Register

Bit(s)	Pin #	Name	Control Function	Type	0	1	Default
Bit 7		CPU N Div8	N Divider Prog bit 8	RW	The decimal representation of M and N Divider in Byte 4 and 5 will configure the CPU VCO frequency. Default at power up = latch-in. VCO Frequency = $14.318 \times [\text{NDiv}(11:0)] / [\text{MDiv}(5:0)]$		X
Bit 6		CPU N Div9	N Divider Prog bit 9	RW			X
Bit 5		CPU M Div5	M Divider Programming bit (5:0)	RW			X
Bit 4		CPU M Div4		RW			X
Bit 3		CPU M Div3		RW			X
Bit 2		CPU M Div2		RW			X
Bit 1		CPU M Div1		RW			X
Bit 0		CPU M Div0		RW			X

Byte 5 CPU PLL M/N Register

Bit(s)	Pin #	Name	Control Function	Type	0	1	Default
Bit 7		CPU N Div7	N Divider Programming Byte5 bit(7:0) and Byte5 bit(7:6)	RW	The decimal representation of M and N Divider in Byte 4 and 5 will configure the CPU VCO frequency. Default at power up = latch-in. VCO Frequency = $14.318 \times [\text{NDiv}(11:0)] / [\text{MDiv}(5:0)]$		X
Bit 6		CPU N Div6		RW			X
Bit 5		CPU N Div5		RW			X
Bit 4		CPU N Div4		RW			X
Bit 3		CPU N Div3		RW			X
Bit 2		CPU N Div2		RW			X
Bit 1		CPU N Div1		RW			X
Bit 0		CPU N Div0		RW			X

Byte 6 DOT96 PLL M/N Register

Bit(s)	Pin #	Name	Control Function	Type	0	1	Default
Bit 7		DOT N Div8	N Divider Prog bit 8	RW	The decimal representation of M and N Divider in Byte 6 and 7 will configure the DOT VCO frequency. VCO Frequency = $14.318 \times [\text{NDiv}(11:0)] / [\text{MDiv}(5:0)]$		X
Bit 6		DOT N Div9	N Divider Prog bit 9	RW			X
Bit 5		DOT M Div5	M Divider Programming bit (5:0)	RW			X
Bit 4		DOT M Div4		RW			X
Bit 3		DOT M Div3		RW			X
Bit 2		DOT M Div2		RW			X
Bit 1		DOT M Div1		RW			X
Bit 0		DOT M Div0		RW			X

Byte 7 DOT96 PLL M/N Register

Bit(s)	Pin #	Name	Control Function	Type	0	1	Default
Bit 7		DOT N Div7	N Divider Programming Byte7 bit(7:0) and Byte6 bit(7:6)	RW	The decimal representation of M and N Divider in Byte 6 and 7 will configure the DOT VCO frequency. VCO Frequency = $14.318 \times [\text{NDiv}(11:0)] / [\text{MDiv}(5:0)]$		X
Bit 6		DOT N Div6		RW			X
Bit 5		DOT N Div5		RW			X
Bit 4		DOT N Div4		RW			X
Bit 3		DOT N Div3		RW			X
Bit 2		DOT N Div2		RW			X
Bit 1		DOT N Div1		RW			X
Bit 0		DOT N Div0		RW			X

Byte 8 LCD100 PLL M/N Register

Bit(s)	Pin #	Name	Control Function	Type	0	1	Default
Bit 7		LCD100 N Div8	N Divider Prog bit 8	RW	The decimal representation of M and N Divider in Byte 8 and 9 will configure the DOT VCO frequency. VCO Frequency = $14.318 \times [\text{NDiv}(11:0)] / [\text{MDiv}(5:0)]$		X
Bit 6		LCD100 N Div9	N Divider Prog bit 9	RW		X	
Bit 5		LCD100 M Div5	M Divider Programming bit (5:0)	RW		X	
Bit 4		LCD100 M Div4		RW		X	
Bit 3		LCD100 M Div3		RW		X	
Bit 2		LCD100 M Div2		RW		X	
Bit 1		LCD100 M Div1		RW		X	
Bit 0		LCD100 M Div0		RW		X	

Byte 9 LCD100 PLL M/N Register

Bit(s)	Pin #	Name	Control Function	Type	0	1	Default
Bit 7		LCD100 N Div7	N Divider Programming Byte9 bit(7:0) and Byte8 bit(7:6)	RW	The decimal representation of M and N Divider in Byte 8 and 9 will configure the DOT VCO frequency. VCO Frequency = $14.318 \times [\text{NDiv}(11:0)] / [\text{MDiv}(5:0)]$		X
Bit 6		LCD100 N Div6		RW		X	
Bit 5		LCD100 N Div5		RW		X	
Bit 4		LCD100 N Div4		RW		X	
Bit 3		LCD100 N Div3		RW		X	
Bit 2		LCD100 N Div2		RW		X	
Bit 1		LCD100 N Div1		RW		X	
Bit 0		LCD100 N Div0		RW		X	

Byte 10 Status Readback Register

Bit(s)	Pin #	Name	Description	Type	0	1	Default
7	37	FSB	Frequency Select B	R	See Table 1: CPU Frequency Select Table		Latch
6	9	FSC	Frequency Select C	R			Latch
5	24	CR0# Readbk	Real time CR0# State Indicator	R	CR0# is Low	CR0# is High	X
4	28	CR1# Readbk	Real time CR1# State Indicator	R	CR1# is Low	CR1# is High	X
3	36	CR2# Readbk	Real time CR2# State Indicator	R	CR2# is Low	CR2# is High	X
2		Reserved					0
1		Reserved					0
0		Reserved					0

Byte 11 Revision ID/Vendor ID Register

Bit(s)	Pin #	Name	Description	Type	0	1	Default	
7		Rev Code Bit 3	Revision ID	R	Vendor specific		X	
6		Rev Code Bit 2		R		X		
5		Rev Code Bit 1		R		X		
4		Rev Code Bit 0		R		X		
3		Vendor ID bit 3	Vendor ID	R				0
2		Vendor ID bit 2		R				0
1		Vendor ID bit 1		R				0
0		Vendor ID bit 0		R				1

**Byte 12 Device ID Register**

Bit(s)	Pin #	Name	Description	Type	0	1	Default
7		DEV_ID3	Device ID MSB	R			1
6		DEV_ID2	Device ID 2	R			0
5		DEV_ID1	Device ID 1	R			1
4		DEV_ID0	Device ID LSB	R			0
3		Reserved					0
2		Reserved					0
1		Reserved					0
0		Reserved					0

**Byte 13 Reserved Register**

Bit(s)	Pin #	Name	Control Function	Type	0	1	Default
Bit 7		Reserved					0
Bit 6		Reserved					0
Bit 5		Reserved					0
Bit 4		Reserved					0
Bit 3		Reserved					0
Bit 2		Reserved					0
Bit 1		Reserved					0
Bit 0		Reserved					0

**Byte 14 Reserved Register**

Bit(s)	Pin #	Name	Control Function	Type	0	1	Default
Bit 7		Reserved					0
Bit 6		Reserved					0
Bit 5		Reserved					0
Bit 4		Reserved					0
Bit 3		Reserved					0
Bit 2		Reserved					0
Bit 1		Reserved					0
Bit 0		Reserved					0

**Byte 15 Byte Count Register**

Bit(s)	Pin #	Name	Control Function	Type	0	1	Default
Bit 7		Reserved					0
Bit 6		BC6	Byte Count 6 (MSB)	RW	Specifies Number of bytes to be read back during an SMBus read. Default is 0xF.		0
Bit 5		BC5	Byte Count 5	RW		0	
Bit 4		BC4	Byte Count 4	RW		0	
Bit 3		BC3	Byte Count 3	RW		1	
Bit 2		BC2	Byte Count 2	RW		1	
Bit 1		BC1	Byte Count 1	RW		1	
Bit 0		BC0	Byte Count LSB	RW		1	

Byte 16 M/N Enable Register

Bit(s)	Pin #	Name	Control Function	Type	0	1	Default
Bit 7		MN Enable	Enables PLL MN programming	RW	MN Disabled	MN Enabled	0
Bit 6		Reserved					0
Bit 5		Reserved					0
Bit 4		Reserved					0
Bit 3		Reserved					0
Bit 2		Reserved					0
Bit 1		Reserved					0
Bit 0		Reserved					0

Byte 17 CPU PLL Spread Spectrum Index Register

Bit(s)	Pin #	Name	Control Function	Type	0	1	Default
Bit 7		CPUSSP7	Spread Spectrum Programming bit(7:0) Contact IDT before editing these values.	RW	These Spread Spectrum bits in Byte 17 and 18 will program the spread percentage of the CPU and SRC outputs		X
Bit 6		CPUSSP6		RW			X
Bit 5		CPUSSP5		RW			X
Bit 4		CPUSSP4		RW			X
Bit 3		CPUSSP3		RW			X
Bit 2		CPUSSP2		RW			X
Bit 1		CPUSSP1		RW			X
Bit 0		CPUSSP0		RW			X

Byte 18 CPU PLL Spread Spectrum Index Register

Bit(s)	Pin #	Name	Control Function	Type	0	1	Default
Bit 7		CPUSSP15	Spread Spectrum Programming bit(15:8) Contact IDT before editing these values.	RW	These Spread Spectrum bits in Byte 17 and 18 will program the spread percentage of the CPU and SRC outputs		X
Bit 6		CPUSSP14		RW			X
Bit 5		CPUSSP13		RW			X
Bit 4		CPUSSP12		RW			X
Bit 3		CPUSSP11		RW			X
Bit 2		CPUSSP10		RW			X
Bit 1		CPUSSP9		RW			X
Bit 0		CPUSSP8		RW			X

Byte 19 LCD100 PLL Spread Spectrum Index Register

Bit(s)	Pin #	Name	Control Function	Type	0	1	Default
Bit 7		LCDSSP7	Spread Spectrum Programming bit(7:0) Contact IDT before editing these values.	RW	These Spread Spectrum bits in Byte 19 and 20 will program the spread percentage of the CPU and SRC outputs		X
Bit 6		LCDSSP6		RW			X
Bit 5		LCDSSP5		RW			X
Bit 4		LCDSSP4		RW			X
Bit 3		LCDSSP3		RW			X
Bit 2		LCDSSP2		RW			X
Bit 1		LCDSSP1		RW			X
Bit 0		LCDSSP0		RW			X

**Byte 20 LCD100 PLL Spread Spectrum Index Register**

Bit(s)	Pin #	Name	Control Function	Type	0	1	Default
Bit 7		LCDSSP15	Spread Spectrum Programming bit(15:8) Contact IDT before editing these values.	RW	These Spread Spectrum bits in Byte 19 and 20 will program the spread percentage of the CPU and SRC outputs		X
Bit 6		LCDSSP14		RW			X
Bit 5		LCDSSP13		RW			X
Bit 4		LCDSSP12		RW			X
Bit 3		LCDSSP11		RW			X
Bit 2		LCDSSP10		RW			X
Bit 1		LCDSSP9		RW			X
Bit 0		LCDSSP8		RW			X

**Byte 21 CPU PLL M/N Register**

Bit(s)	Pin #	Name	Control Function	Type	0	1	Default
Bit 7		CPU NDIV 10	N Divider Prog bit 10	RW	See Byte 4/5 Description		X
Bit 6		CPU NDIV 11	N Divider Prog bit 11	RW			X
Bit 5		Reserved					0
Bit 4		Reserved					0
Bit 3		Reserved					0
Bit 2		Reserved					0
Bit 1		Reserved					0
Bit 0		Reserved					0

**Byte 22 LCD100 PLL M/N Register**

Bit(s)	Pin #	Name	Control Function	Type	0	1	Default
Bit 7		LCD NDIV 10	N Divider Prog bit 10	RW	See Byte 8/9 Description		X
Bit 6		LCD NDIV 11	N Divider Prog bit 11	RW			X
Bit 5		Reserved					0
Bit 4		Reserved					0
Bit 3		Reserved					0
Bit 2		Reserved					0
Bit 1		Reserved					0
Bit 0		Reserved					0



**Test Clarification Table**

Comments	HW		OUTPUT
	TEST_SEL HW PIN	TEST_MODE HW PIN	
	<0.35V	X	NORMAL
Power-up w/ TEST_SEL = 1 to enter test mode Cycle power to disable test mode TEST_MODE -->low Vth input TEST_MODE is a real time input	>0.7V	<0.35V	HI-Z
	>0.7V	>0.7V	REF/N

MLF Top Mark Information (9UMS9610)

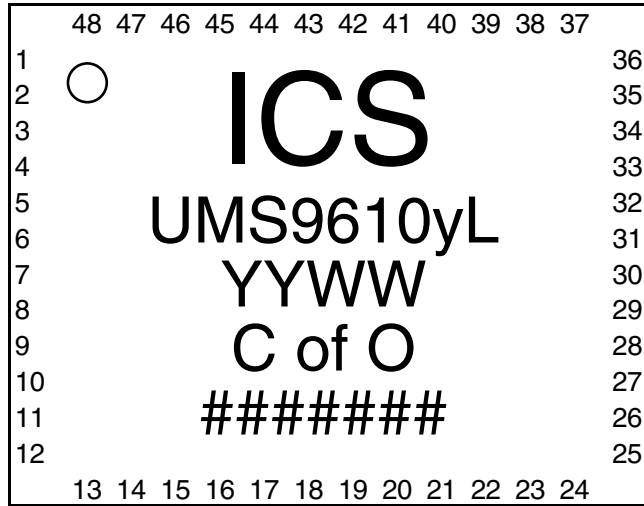

- Line 1. Company name
- Line 2. Part Number
- Line 3. YYWW = Date Code
- Line 3. Country of Origin
- Line 4. ##### = Lot Number

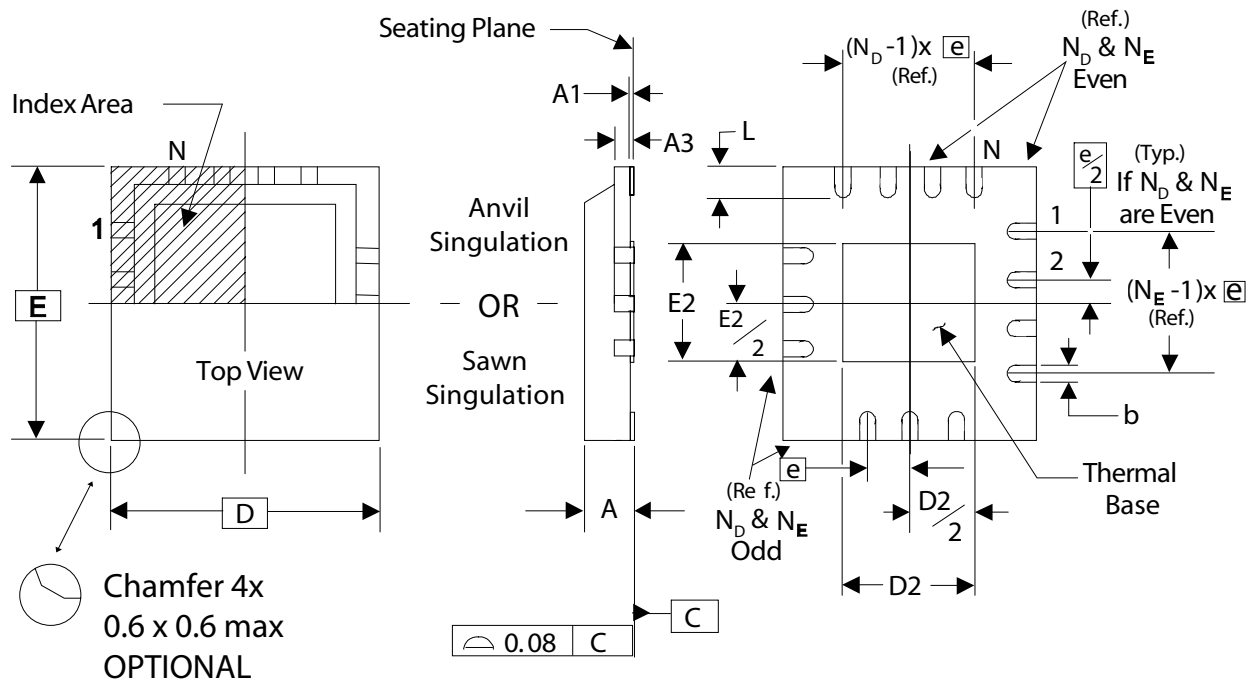

THEMALLY ENHANCED, VERY THIN, FINE PITCH  
QUAD FLAT / NO LEAD PLASTIC PACKAGE

DIMENSIONS

SYMBOL	MIN.	MAX.
A	0.8	1.0
A1	0	0.05
A3	0.20 Reference	
b	0.18	0.3
e	0.40 BASIC	

DIMENSIONS

SYMBOL	48L TOLERANCE
N	48
$N_D$	12
$N_E$	12
D x E BASIC	6.00 x 6.00
D2 MIN. / MAX.	3.95 / 4.25
E2 MIN. / MAX.	3.95 / 4.25
L MIN. / MAX.	0.30 / 0.50

## Ordering Information

Part / Order Number	Marking	Shipping Packaging	Package	Temperature
9UMS9610CKLF	see page 18	Tubes	48-pin MLF	0 to +85° C
9UMS9610CKLFT		Tape and Reel	48-pin MLF	0 to +85° C

Parts that are ordered with a "LF" suffix to the part number are the Pb-Free configuration and are RoHS compliant.

## Revision History

Rev.	Issue Date	Description	Page #
0.1	04/25/07	Initial Release	-
0.15	05/03/07	Corrected CLKPWRGD#/PD polarity	1
0.2	5/18/2007	Updated Test Clarification Table with the correct voltage levels.	-
0.3	8/31/2007	Updated Input Pin names to indicate maximum Input voltage level	-
0.4	9/11/2007	Added Logic Level and Input Level Tolerance Columns to Pin Descriptions.	2, 3
0.5	9/13/2007	Clarified that X1 is 1.5V only input	2
0.6	10/23/007	1. Byte Count in Byte 15 is 7 bits, not 8 bits. B15b7 is now reserved. 2. Modified PLL programming formulas in Bytes(4:9). N is 12 bits instead of 10 bits. 3. Changed REF_3.3 output name to reflect default drive strength (new name is REF_3.3_2x).	Various
0.7	11/6/2007	Updated Bytes [9:4].	12-13
0.8	11/29/2007	Added Bytes 16-22 to the SMBUS.	15-16
0.9	2/26/2008	Added MLF Top Mark Information.	18
0.91	7/8/2008	Updated Electrical Specifications	5-7
0.92	7/21/2008	Updated Electrical Specifications	5-7
A	5/21/2009	Moved to final.	-
B	6/1/2009	Updated electrical specs; TA spec in ordering information.	Various

## IMPORTANT NOTICE AND DISCLAIMER

RENESAS ELECTRONICS CORPORATION AND ITS SUBSIDIARIES (“RENESAS”) PROVIDES TECHNICAL SPECIFICATIONS AND RELIABILITY DATA (INCLUDING DATASHEETS), DESIGN RESOURCES (INCLUDING REFERENCE DESIGNS), APPLICATION OR OTHER DESIGN ADVICE, WEB TOOLS, SAFETY INFORMATION, AND OTHER RESOURCES “AS IS” AND WITH ALL FAULTS, AND DISCLAIMS ALL WARRANTIES, EXPRESS OR IMPLIED, INCLUDING, WITHOUT LIMITATION, ANY IMPLIED WARRANTIES OF MERCHANTABILITY, FITNESS FOR A PARTICULAR PURPOSE, OR NON-INFRINGEMENT OF THIRD-PARTY INTELLECTUAL PROPERTY RIGHTS.

These resources are intended for developers who are designing with Renesas products. You are solely responsible for (1) selecting the appropriate products for your application, (2) designing, validating, and testing your application, and (3) ensuring your application meets applicable standards, and any other safety, security, or other requirements. These resources are subject to change without notice. Renesas grants you permission to use these resources only to develop an application that uses Renesas products. Other reproduction or use of these resources is strictly prohibited. No license is granted to any other Renesas intellectual property or to any third-party intellectual property. Renesas disclaims responsibility for, and you will fully indemnify Renesas and its representatives against, any claims, damages, costs, losses, or liabilities arising from your use of these resources. Renesas' products are provided only subject to Renesas' Terms and Conditions of Sale or other applicable terms agreed to in writing. No use of any Renesas resources expands or otherwise alters any applicable warranties or warranty disclaimers for these products.

(Disclaimer Rev.1.01 Jan 2024)

### Corporate Headquarters

TOYOSU FORESIA, 3-2-24 Toyosu,  
Koto-ku, Tokyo 135-0061, Japan  
[www.renesas.com](http://www.renesas.com)

### Trademarks

Renesas and the Renesas logo are trademarks of Renesas Electronics Corporation. All trademarks and registered trademarks are the property of their respective owners.

### Contact Information

For further information on a product, technology, the most up-to-date version of a document, or your nearest sales office, please visit [www.renesas.com/contact-us/](http://www.renesas.com/contact-us/).