

AD7520, AD7521

10-Bit, 12-Bit, Multiplying D/A Converters

FN3104
Rev.4.00
August 2002

The AD7520 and AD7521 are monolithic, high accuracy, low cost 10-bit and 12-bit resolution, multiplying digital-to-analog converters (DAC). Intersil's thin-film on CMOS processing gives up to 10-bit accuracy with TTL/CMOS compatible operation. Digital inputs are fully protected against static discharge by diodes to ground and positive supply.

Typical applications include digital/analog interfacing, multiplication and division, programmable power supplies, CRT character generation, digitally controlled gain circuits, integrators and attenuators, etc.

Features

- AD7520, 10-Bit Resolution; 8-Bit Linearity
- AD7521, 12-Bit Resolution; 10-Bit Linearity
- Low Power Dissipation (Max). 20mW
- Low Nonlinearity Tempco at 2ppm of FSR/°C
- Current Settling Time to 0.05% of FSR 1.0µs
- Supply Voltage Range ±5V to +15V
- TTL/CMOS Compatible
- Full Input Static Protection

Ordering Information

PART NUMBER	LINEARITY (INL, DNL)	TEMP. RANGE (°C)	PACKAGE	PKG. NO.
AD7520JN	0.2% (8-Bit)	0 to 70	16 Ld PDIP	E16.3
AD7521LN	0.05% (10-Bit)	0 to 70	18 Ld PDIP	E18.3

Pinouts

AD7520 (PDIP)
TOP VIEW

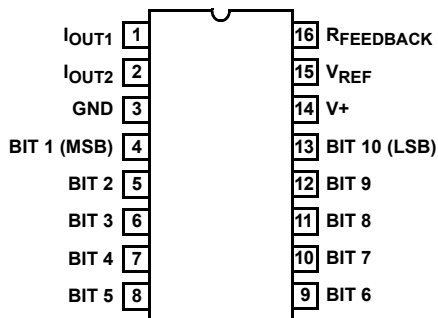

AD7521 (PDIP)
TOP VIEW

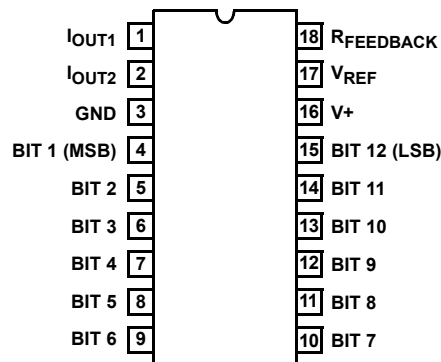

Absolute Maximum Ratings

Supply Voltage (V+ to GND)	+17V
V _{REF}	±25V
Digital Input Voltage Range	V+ to GND
Output Voltage Compliance	-100mV to V+

Operating Conditions

Temperature Ranges

JN, LN Versions 0°C to 70°C

CAUTION: Stresses above those listed in "Absolute Maximum Ratings" may cause permanent damage to the device. This is a stress only rating and operation of the device at these or any other conditions above those indicated in the operational sections of this specification is not implied.

The digital control inputs are zener protected; however, permanent damage may occur on unconnected units under high energy electrostatic fields. Keep unused units in conductive foam at all times.

Do not apply voltages higher than V_{DD} or less than GND potential on any terminal except V_{REF} and R_{FEEDBACK}.

1. θ_{JA} is measured with the component mounted on a low effective thermal conductivity test board in free air. See Tech Brief TB379 for details.

Thermal Information

Thermal Resistance (Typical, Note 1)	θ_{JA} (°C/W)	θ_{JC} (°C/W)
16 Ld PDIP Package	90	N/A
18 Ld PDIP Package	80	N/A
Maximum Junction Temperature (Plastic Packages)	150°C	
Maximum Storage Temperature Range	-65°C to 150°C	
Maximum Lead Temperature (Soldering 10s)	300°C	

Electrical Specifications V+ = +15V, V_{REF} = +10V, T_A = 25°C Unless Otherwise Specified

PARAMETER	TEST CONDITIONS	AD7520			AD7521			UNITS	
		MIN	TYP	MAX	MIN	TYP	MAX		
SYSTEM PERFORMANCE (Note 2)									
Resolution		10	10	10	12	12	12	Bits	
Nonlinearity	J	(Note 3) (Figure 2) -10V ≤ V _{REF} ≤ +10V	-	-	±0.2 (8-Bit)	-	-	-	% of FSR
	L	-10V ≤ V _{REF} ≤ +10V (Figure 2)	-	-	±0.05 (10-Bit)	-	-	±0.05 (10-Bit)	% of FSR
Nonlinearity Tempco		-10V ≤ V _{REF} ≤ +10V (Notes 3, 4)	-	-	±2	-	-	±2	ppm of FSR/°C
Gain Error			-	±0.3	-	-	±0.3	-	% of FSR
Gain Error Tempco			-	-	±10	-	-	±10	ppm of FSR/°C
Output Leakage Current (Either Output)	Over the Specified Temperature Range	-	-	±200	-	-	±200	nA	
DYNAMIC CHARACTERISTICS									
Output Current Settling Time	To 0.05% of FSR (All Digital Inputs Low To High And High To Low) (Note 4) (Figure 7)	-	1.0	-	-	1.0	-	µs	
Feedthrough Error	V _{REF} = 20V _{P-P} , 100kHz All Digital Inputs Low (Note 4) (Figure 6)	-	-	10	-	-	10	mV _{P-P}	
REFERENCE INPUT									
Input Resistance	All Digital Inputs High I _{OUT1} at Ground	5	10	20	5	10	20	kΩ	
ANALOG OUTPUT									
Output Capacitance	I _{OUT1}	All Digital Inputs High (Note 4) (Figure 5)	-	200	-	-	200	-	pF
			-	75	-	-	75	-	pF
	I _{OUT2}	All Digital Inputs Low (Note 4) (Figure 5)	-	75	-	-	75	-	pF
			-	200	-	-	200	-	pF
Output Noise	Both Outputs (Note 4) (Figure 4)	-	Equivalent to 10kΩ	-	-	Equivalent to 10kΩ	-	Johnson Noise	
DIGITAL INPUTS									
Low State Threshold, V _{IL}	Over the Specified Temperature Range V _{IN} = 0V or +15V	-	-	0.8	-	-	0.8	V	
High State Threshold, V _{IH}		2.4	-	-	2.4	-	-	V	
Input Current, I _{IL} , I _{IH}		-	-	±1	-	-	±1	µA	
Input Coding	See Tables 1 and 2	Binary/Offset Binary							

Electrical Specifications $V_+ = +15V$, $V_{REF} = +10V$, $T_A = 25^\circ C$ Unless Otherwise Specified (Continued)

PARAMETER	TEST CONDITIONS	AD7520			AD7521			UNITS
		MIN	TYP	MAX	MIN	TYP	MAX	
POWER SUPPLY CHARACTERISTICS								
Power Supply Rejection	$V_+ = 14.5V$ to $15.5V$ (Note 3) (Figure 3)	-	± 0.005	-	-	± 0.005	-	% FSR/% ΔV_+
Power Supply Voltage Range		+5 to +15			+5 to +15			V
I_+	All Digital Inputs at 0V or V_+ Excluding Ladder Network	-	± 1	-	-	± 1	-	μA
	All Digital Inputs High or Low Excluding Ladder Network	-	-	2	-	-	2	mA
Total Power Dissipation	Including the Ladder Network	-	20	-	-	20	-	mW

NOTES:

- Full Scale Range (FSR) is 10V for Unipolar and $\pm 10V$ for Bipolar modes.
- Using internal feedback resistor $R_{FEEDBACK}$.
- Guaranteed by design, or characterization and not production tested.
- Accuracy not guaranteed unless outputs at GND potential.
- Accuracy is tested and guaranteed at $V_+ = 15V$ only.

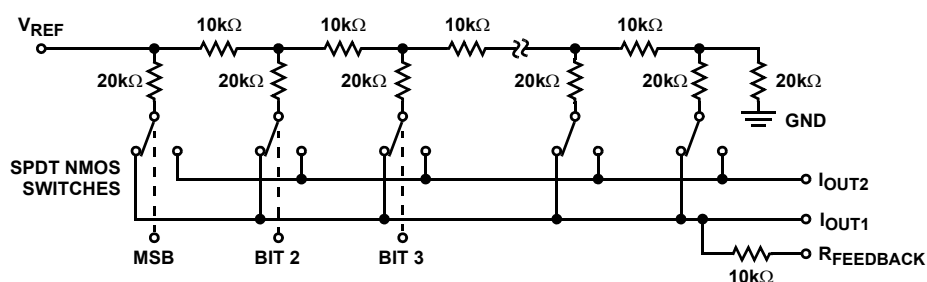
Functional Diagram

NOTES:

Switches shown for Digital Inputs "High".
Resistor values are typical.

Pin Descriptions

AD7520	AD7521	PIN NAME	DESCRIPTION
1	1	IOUT1	Current Out summing junction of the R2R ladder network.
2	2	IOUT2	Current Out virtual ground, return path for the R2R ladder network.
3	3	GND	Digital Ground. Ground potential for digital side of D/A.
4	4	Bits 1 (MSB)	Most Significant Digital Data Bit.
5	5	Bit 2	Digital Bit 2.
6	6	Bit 3	Digital Bit 3.
7	7	Bit 4	Digital Bit 4.
8	8	Bit 5	Digital Bit 5.
9	9	Bit 6	Digital Bit 6.
10	10	Bit 7	Digital Bit 7.
11	11	Bit 8	Digital Bit 8.
12	12	Bit 9	Digital Bit 9.
13	13	Bit 10	Digital Bit 10 (AD7521). Least Significant Digital Data Bit (AD7520).
-	14	Bit 11	Digital Bit 11 (AD7521).
-	15	Bit 12	Least Significant Digital Data Bit (AD7521).
14	16	V_+	Power Supply +5V to +15V.
15	17	V_{REF}	Voltage Reference Input to set the output range. Supplies the R2R resistor ladder.
16	18	RFEEDBACK	Feedback resistor used for the current to voltage conversion when using an external Op Amp.

Definition of Terms

Nonlinearity: Error contributed by deviation of the DAC transfer function from a “best straight line” through the actual plot of transfer function. Normally expressed as a percentage of full scale range or in (sub)multiples of 1 LSB.

Resolution: It is addressing the smallest distinct analog output change that a D/A converter can produce. It is commonly expressed as the number of converter bits. A converter with resolution of N bits can resolve output changes of 2^{-N} of the full-scale range, e.g., $2^{-N} V_{REF}$ for a unipolar conversion. Resolution by no means implies linearity.

Settling Time: Time required for the output of a DAC to settle to within specified error band around its final value (e.g., $1/2$ LSB) for a given digital input change, i.e., all digital inputs LOW to HIGH and HIGH to LOW.

Gain Error: The difference between actual and ideal analog output values at full scale range, i.e., all digital inputs at HIGH state. It is expressed as a percentage of full scale range or in (sub)multiples of 1 LSB.

Feedthrough Error: Error caused by capacitive coupling from V_{REF} to I_{OUT1} with all digital inputs LOW.

Output Capacitance: Capacitance from I_{OUT1} and I_{OUT2} terminals to ground.

Output Leakage Current: Current which appears on I_{OUT1} terminal when all digital inputs are LOW or on I_{OUT2} terminal when all digital inputs are HIGH.

Detailed Description

The AD7520 and AD7521 are monolithic, multiplying D/A converters. A highly stable thin film R-2R resistor ladder network and NMOS SPDT switches form the basis of the converter circuit, CMOS level shifters permit low power TTL/CMOS compatible operation. An external voltage or

current reference and an operational amplifier are all that is required for most voltage output applications.

A simplified equivalent circuit of the DAC is shown in the *Functional Diagram*. The NMOS SPDT switches steer the ladder leg currents between I_{OUT1} and I_{OUT2} buses which must be held either at ground potential. This configuration maintains a constant current in each ladder leg independent of the input code.

Converter errors are further reduced by using separate metal interconnections between the major bits and the outputs. Use of high threshold switches reduce offset (leakage) errors to a negligible level.

The level shifter circuits are comprised of three inverters with positive feedback from the output of the second to the first, see Figure 1. This configuration results in TTL/CMOS compatible operation over the full military temperature range. With the ladder SPDT switches driven by the level shifter, each switch is binarily weighted for an ON resistance proportional to the respective ladder leg current. This assures a constant voltage drop across each switch, creating equipotential terminations for the 2R ladder resistors and highly accurate leg currents.

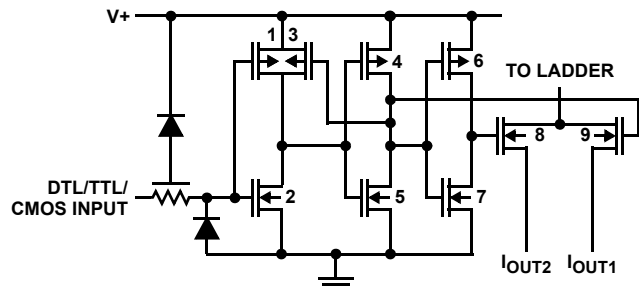

FIGURE 1. CMOS LEVEL SHIFTER AND SWITCH

Test Circuits The following test circuits apply for the AD7520. Similar circuits are used for the AD7521.

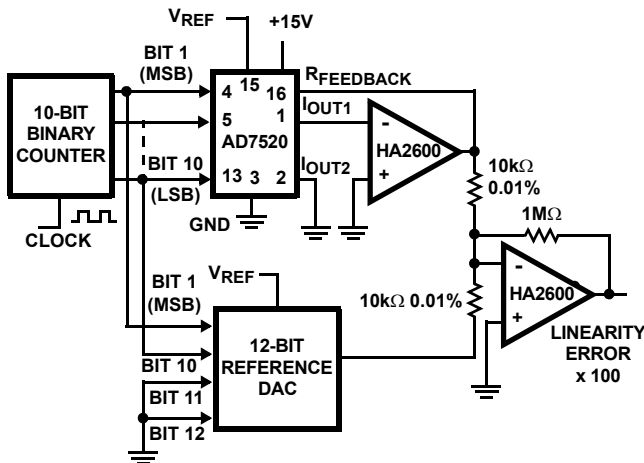

FIGURE 2. NONLINEARITY

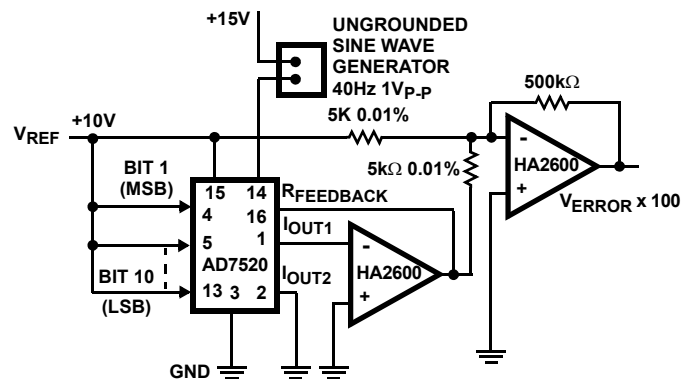

FIGURE 3. POWER SUPPLY REJECTION

Test Circuits The following test circuits apply for the AD7520. Similar circuits are used for the AD7521. (Continued)

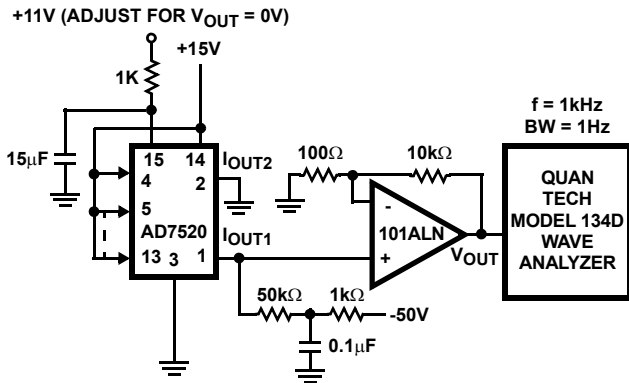

FIGURE 4. NOISE

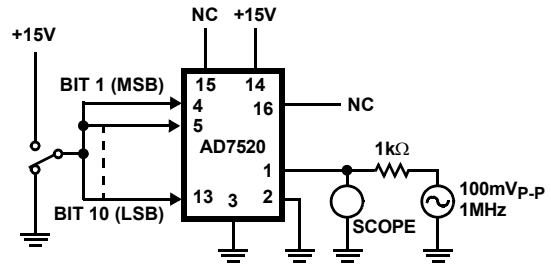

FIGURE 5. OUTPUT CAPACITANCE

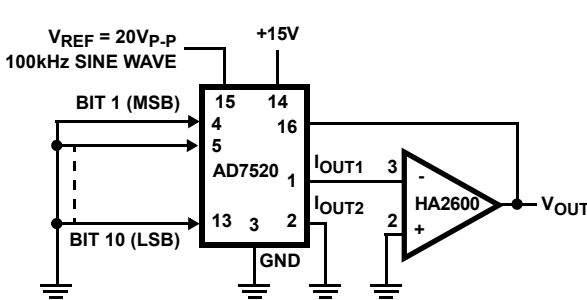

FIGURE 6. FEEDTHROUGH ERROR

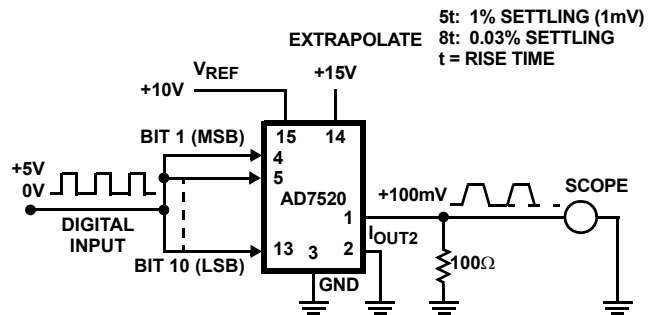

FIGURE 7. OUTPUT CURRENT SETTLING TIME

Applications

Unipolar Binary Operation

The circuit configuration for operating the AD7520 in unipolar mode is shown in Figure 8. Similar circuits can be used for AD7521. With positive and negative V_{REF} values the circuit is capable of 2-Quadrant multiplication. The *Digital Input Code/Analog Output Value* table for unipolar mode is given in Table 1.

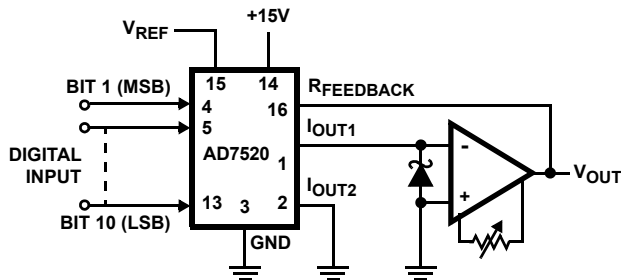

FIGURE 8. UNIPOLAR BINARY OPERATION (2-QUADRANT MULTIPLICATION)

TABLE 1. CODE TABLE - UNIPOLAR BINARY OPERATION

DIGITAL INPUT	ANALOG OUTPUT
1111111111	$-V_{REF} (1-2^{-N})$
1000000001	$-V_{REF} (\frac{1}{2} + 2^{-N})$
1000000000	$-V_{REF}/2$
0111111111	$-V_{REF} (\frac{1}{2}-2^{-N})$
0000000001	$-V_{REF} (2^{-N})$
0000000000	0

NOTES:

1. $LSB = 2^{-N} V_{REF}$.
2. $N = 8$ for 7520
 $N = 10$ for 7521.

Zero Offset Adjustment

1. Connect all digital inputs to GND.
2. Adjust the offset zero adjust trimpot of the output operational amplifier for 0V at V_{OUT} .

Gain Adjustment

1. Connect all digital inputs to $V+$.
2. Monitor V_{OUT} for a $-V_{REF} (1-2^{-N})$ reading. ($N = 8$ for AD7520 and $N = 10$ for AD7521).

- To decrease V_{OUT} , connect a series resistor (0 to 250Ω) between the reference voltage and the V_{REF} terminal.
- To increase V_{OUT} , connect a series resistor (0 to 250Ω) in the I_{OUT1} amplifier feedback loop.

Bipolar (Offset Binary) Operation

The circuit configuration for operating the AD7520 in the bipolar mode is given in Figure 9. Similar circuits can be used for AD7521. Using offset binary digital input codes and positive and negative reference voltage values, 4-Quadrant multiplication can be realized. The “Digital Input Code/Analog Output Value” table for bipolar mode is given in Table 2.

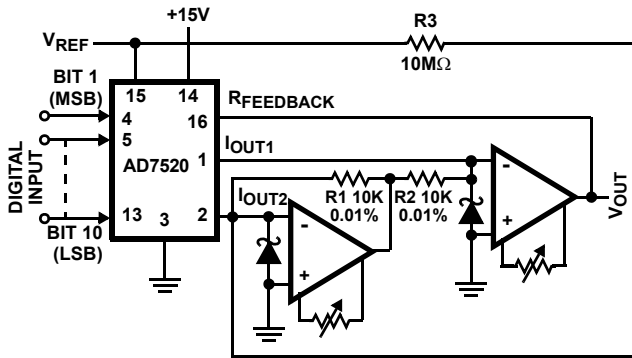

FIGURE 9. BIPOLAR OPERATION (4-QUADRANT MULTIPLICATION)

TABLE 2. BIPOLAR (OFFSET BINARY) CODE TABLE

DIGITAL INPUT	ANALOG OUTPUT
1111111111	$-V_{REF} (1-2^{-(N-1)})$
1000000001	$-V_{REF} (2^{-(N-1)})$
1000000000	0
0111111111	$V_{REF} (2^{-(N-1)})$
0000000001	$V_{REF} (1-2^{-(N-1)})$
0000000000	V_{REF}

NOTES:

- $LSB = 2^{-(N-1)} V_{REF}$.
- $N = 8$ for 7520
 $N = 10$ for 7521.

A “Logic 1” input at any digital input forces the corresponding ladder switch to steer the bit current to IOUT1 bus. A “Logic 0” input forces the bit current to IOUT2 bus. For any code the IOUT1 and IOUT2 bus currents are complements of one another. The current amplifier at IOUT2 changes the polarity of IOUT2 current and the transconductance amplifier at IOUT1 output sums the two currents. This configuration doubles the output range. The difference current resulting at zero offset binary code, (MSB = “Logic 1”, all other bits = “Logic 0”), is corrected by using an external resistor, ($10M\Omega$), from VREF to IOUT2.

Offset Adjustment

- Adjust V_{REF} to approximately +10V.
- Connect all digital inputs to “Logic 1”.
- Adjust I_{OUT2} amplifier offset adjust trimpot for $0V \pm 1mV$ at I_{OUT2} amplifier output.
- Connect MSB (Bit 1) to “Logic 1” and all other bits to “Logic 0”.
- Adjust I_{OUT1} amplifier offset adjust trimpot for $0V \pm 1mV$ at V_{OUT} .

Gain Adjustment

- Connect all digital inputs to $V+$.
- Monitor V_{OUT} for a $-V_{REF} (1-2^{-(N-1)})$ volts reading. ($N = 8$ for AD7520, and $N = 10$ for AD7521.).
- To increase V_{OUT} , connect a series resistor of up to 250Ω between V_{OUT} and $R_{FEEDBACK}$.
- To decrease V_{OUT} , connect a series resistor of up to 250Ω between the reference voltage and the V_{REF} terminal.

Die Characteristics

DIE DIMENSIONS:

101 mils x 103 mils (2565 μ m x 2616 μ m)

METALLIZATION:

Type: Pure Aluminum
 Thickness: 10 \pm 1k \AA

PASSIVATION:

Type: PSG/Nitride
 PSG: 7 \pm 1.4k \AA
 Nitride: 8 \pm 1.2k \AA

PROCESS:

CMOS Metal Gate

Metallization Mask Layout

AD7520

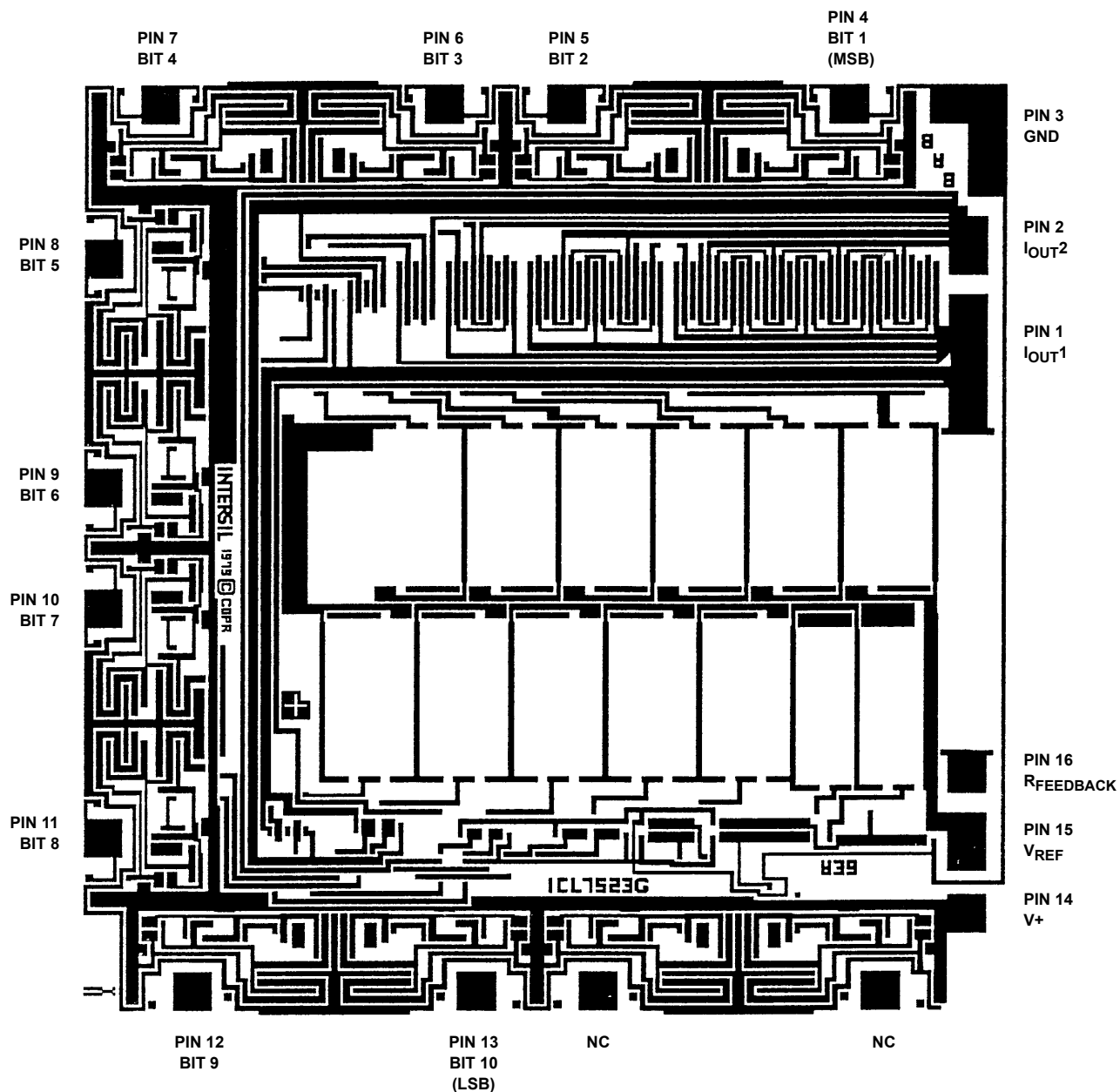

Die Characteristics

DIE DIMENSIONS:

101 mils x 103 mils (2565 μ m x 2616 μ m)

METALLIZATION:

Type: Pure Aluminum

Thickness: 10 \pm 1k \AA

PASSIVATION:

Type: PSG/Nitride

PSG: 7 \pm 1.4k \AA

Nitride: 8 \pm 1.2k \AA

PROCESS:

CMOS Metal Gate

Metallization Mask Layout

AD7521

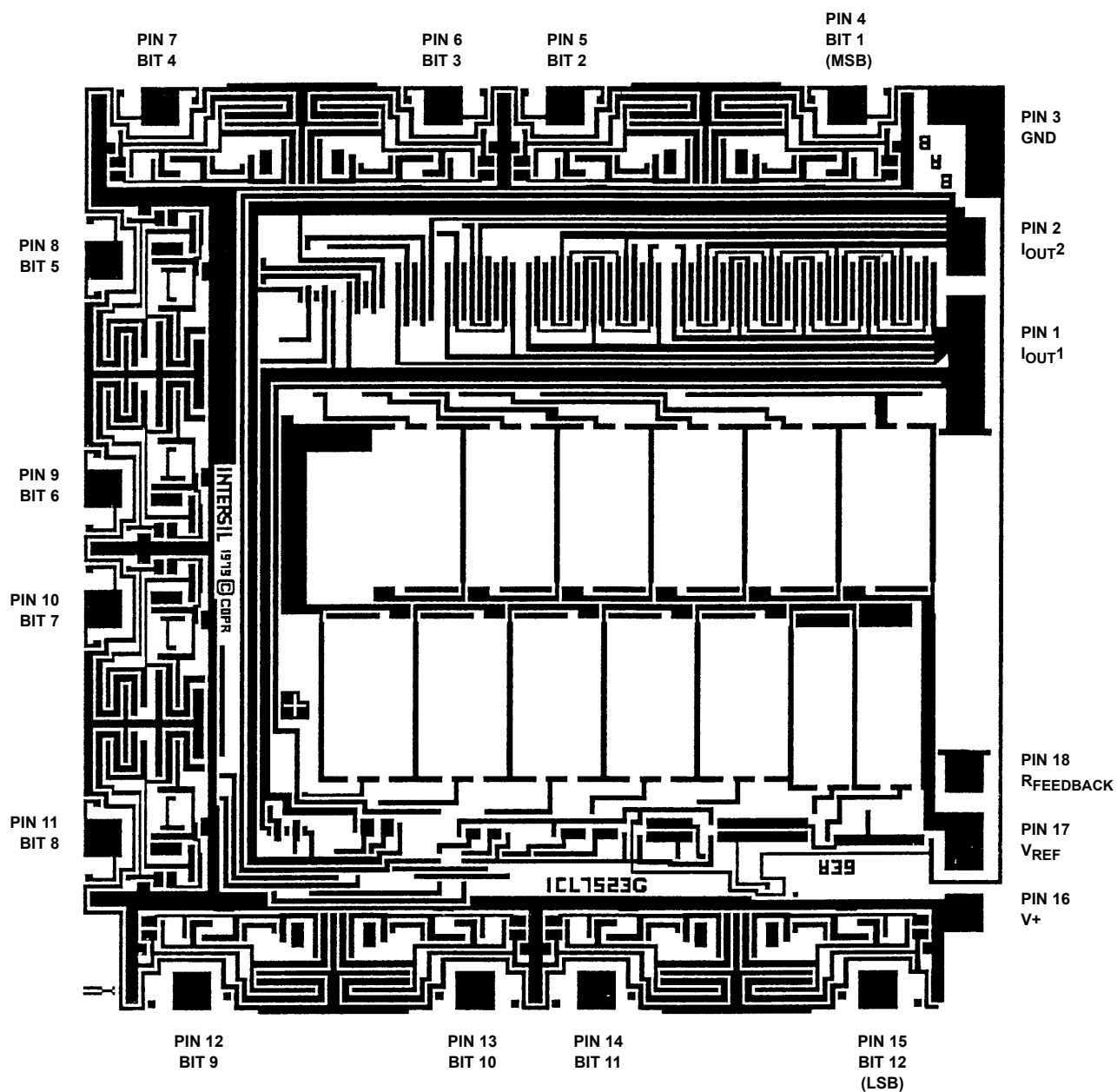

Dual-In-Line Plastic Packages (PDIP)

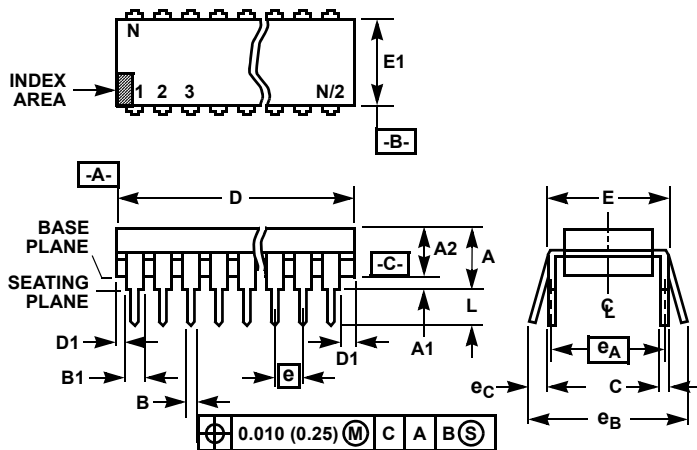

NOTES:

1. Controlling Dimensions: INCH. In case of conflict between English and Metric dimensions, the inch dimensions control.
2. Dimensioning and tolerancing per ANSI Y14.5M-1982.
3. Symbols are defined in the "MO Series Symbol List" in Section 2.2 of Publication No. 95.
4. Dimensions A, A1 and L are measured with the package seated in JEDEC seating plane gauge GS-3.
5. D, D1, and E1 dimensions do not include mold flash or protrusions. Mold flash or protrusions shall not exceed 0.010 inch (0.25mm).
6. E and e_A are measured with the leads constrained to be perpendicular to datum $-C-$.
7. e_B and e_C are measured at the lead tips with the leads unconstrained. e_C must be zero or greater.
8. B1 maximum dimensions do not include dambar protrusions. Dambar protrusions shall not exceed 0.010 inch (0.25mm).
9. N is the maximum number of terminal positions.
10. Corner leads (1, N, N/2 and N/2 + 1) for E8.3, E16.3, E18.3, E28.3, E42.6 will have a B1 dimension of 0.030 - 0.045 inch (0.76 - 1.14mm).

E16.3 (JEDEC MS-001-BB ISSUE D) 16 LEAD DUAL-IN-LINE PLASTIC PACKAGE

SYMBOL	INCHES		MILLIMETERS		NOTES
	MIN	MAX	MIN	MAX	
A	-	0.210	-	5.33	4
A1	0.015	-	0.39	-	4
A2	0.115	0.195	2.93	4.95	-
B	0.014	0.022	0.356	0.558	-
B1	0.045	0.070	1.15	1.77	8, 10
C	0.008	0.014	0.204	0.355	-
D	0.735	0.775	18.66	19.68	5
D1	0.005	-	0.13	-	5
E	0.300	0.325	7.62	8.25	6
E1	0.240	0.280	6.10	7.11	5
e	0.100 BSC		2.54 BSC		-
e_A	0.300 BSC		7.62 BSC		6
e_B	-	0.430	-	10.92	7
L	0.115	0.150	2.93	3.81	4
N	16		16		9

Rev. 0 12/93

Dual-In-Line Plastic Packages (PDIP)

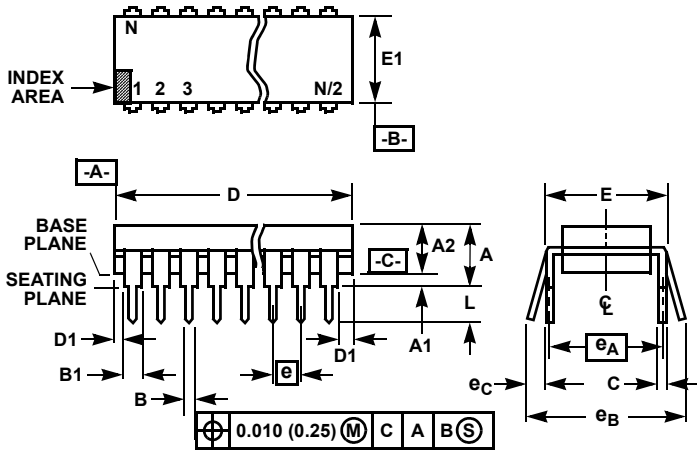

NOTES:

1. Controlling Dimensions: INCH. In case of conflict between English and Metric dimensions, the inch dimensions control.
2. Dimensioning and tolerancing per ANSI Y14.5M-1982.
3. Symbols are defined in the "MO Series Symbol List" in Section 2.2 of Publication No. 95.
4. Dimensions A, A1 and L are measured with the package seated in JEDEC seating plane gauge GS-3.
5. D, D1, and E1 dimensions do not include mold flash or protrusions. Mold flash or protrusions shall not exceed 0.010 inch (0.25mm).
6. E and e_A are measured with the leads constrained to be perpendicular to datum [-C-].
7. e_B and e_C are measured at the lead tips with the leads unconstrained. e_C must be zero or greater.
8. B1 maximum dimensions do not include dambar protrusions. Dambar protrusions shall not exceed 0.010 inch (0.25mm).
9. N is the maximum number of terminal positions.
10. Corner leads (1, N, N/2 and N/2 + 1) for E8.3, E16.3, E18.3, E28.3, E42.6 will have a B1 dimension of 0.030 - 0.045 inch (0.76 - 1.14mm).

**E18.3 (JEDEC MS-001-BC ISSUE D)
18 LEAD DUAL-IN-LINE PLASTIC PACKAGE**

SYMBOL	INCHES		MILLIMETERS		NOTES
	MIN	MAX	MIN	MAX	
A	-	0.210	-	5.33	4
A1	0.015	-	0.39	-	4
A2	0.115	0.195	2.93	4.95	-
B	0.014	0.022	0.356	0.558	-
B1	0.045	0.070	1.15	1.77	8, 10
C	0.008	0.014	0.204	0.355	-
D	0.845	0.880	21.47	22.35	5
D1	0.005	-	0.13	-	5
E	0.300	0.325	7.62	8.25	6
E1	0.240	0.280	6.10	7.11	5
e	0.100 BSC		2.54 BSC		-
e_A	0.300 BSC		7.62 BSC		6
e_B	-	0.430	-	10.92	7
L	0.115	0.150	2.93	3.81	4
N	18		18		9

Rev. 0 12/93

© Copyright Intersil Americas LLC 2002. All Rights Reserved.

All trademarks and registered trademarks are the property of their respective owners.

For additional products, see www.intersil.com/en/products.html

Intersil products are manufactured, assembled and tested utilizing ISO9001 quality systems as noted in the quality certifications found at www.intersil.com/en/support/qualandreliability.html

Intersil products are sold by description only. Intersil may modify the circuit design and/or specifications of products at any time without notice, provided that such modification does not, in Intersil's sole judgment, affect the form, fit or function of the product. Accordingly, the reader is cautioned to verify that datasheets are current before placing orders. Information furnished by Intersil is believed to be accurate and reliable. However, no responsibility is assumed by Intersil or its subsidiaries for its use; nor for any infringements of patents or other rights of third parties which may result from its use. No license is granted by implication or otherwise under any patent or patent rights of Intersil or its subsidiaries.

For information regarding Intersil Corporation and its products, see www.intersil.com