

AT25SF161B

16-Mbit SPI Serial Flash Memory with Dual I/O and Quad I/O Support

Features

- Two supply voltage options:
 - 2.7 V - 3.6 V
 - 2.5 V - 3.6 V
- Serial Peripheral Interface (SPI) Compatible
 - Supports SPI modes 0 and 3
 - Supports dual output operations (1,1,2)
 - Supports quad output operations (1-1-4)
 - Supports quad I/O / XiP operations (1-4-4, 0-4-4)
- 108 MHz maximum operating frequency
- Read operations
 - Fast read up to 108 MHz
 - Continuous read (with 8/16/32/64-byte wrap)
- Flexible erase architecture and time
 - Block erase 4 kB: 50 ms (typical)
 - Block erase 32 kB and 64 kB: 120 ms and 200 ms (typical)
 - Full chip erase: 5.5 seconds (typical)
- Flexible programming and time
 - Page/byte program: from 1 to 256 bytes
 - Page program time: 0.4 ms (typical)
- Erase program suspend resume
- JEDEC Standard Manufacturer and Device ID
- Memory protection support
 - User-definable protected area at start or end of memory array
 - Enable/disable protection with \overline{WP} pin
- 3 x 256-byte One-Time Programmable (OTP) security registers
- Serial Flash Discoverable Parameters (SFDP) register
- Low power dissipation
 - Standby current: 15 μ A (maximum)
 - Deep power-down current: 1.5 μ A (maximum)
- Endurance: 100,000 Program and Erase Cycles
- Data retention: 20 Years
- Temperature range (-40 °C to 85 °C)
- Industry standard green (Pb/Halide-free/RoHS compliant) package options
 - 8-lead SOIC (0.150" Narrow and 0.208" Wide)
 - 8-pad DFN (5 x 6 x 0.6 mm)
 - 8-ball WLCSP (3 x 2 x 3 grid array)
 - Die Wafer Form

Contents

Features	1
Figures	4
Tables	5
1. Product Overview	6
2. Pin Descriptions and Package Pinouts	7
3. Block Diagram	9
4. Memory Array	10
5. Device Operation	12
5.1 Dual Output Read (1-1-2)	12
5.2 Dual I/O Read (1-2-2)	12
5.3 Quad Output Read (1-1-4)	12
5.4 Quad I/O Read (1-4-4)	12
6. Commands and Addressing	13
7. Read Commands	15
7.1 Read Array (0Bh and 03h)	15
7.2 Dual-Output Read Array (3Bh)	16
7.3 Dual-I/O Read Array (BBh)	17
7.4 Quad Output Fast Read Array (6Bh)	18
7.5 Quad-I/O Read Array (EBh)	19
7.6 Quad-I/O Word Fast Read (E7h)	22
7.7 Read Serial Flash Discoverable Parameter (5Ah)	23
8. Program and Erase Commands	24
8.1 Byte/Page Program (02h)	24
8.2 Quad Page Program (32h)	25
8.3 Block Erase (20h, 52h, or D8h)	26
8.4 Chip Erase (60h or C7h)	27
8.5 Program/Erase Suspend (75h)	27
8.6 Program/Erase Resume (7Ah)	28
9. Protection Commands and Features	29
9.1 Write Enable (06h)	29
9.2 Write Disable (04h)	29
9.3 Non-Volatile Protection	30
9.4 Protected States and the Write Protect Pin	31
9.5 Enable Reset (66h) and Reset Device (99h)	32
10. Security Register Commands	33
10.1 Read Unique ID Number (4Bh)	33
10.2 Erase Security Registers (44h)	34
10.3 Program Security Registers (42h)	35
10.4 Read Security Registers (48h)	36
11. Status Register Commands	37
11.1 Read Status Register (05h, 35h, and 15h)	37
11.2 Write Status Register (01h, 31h, 11h)	41
11.3 Write Enable for Volatile Status Register (50h)	42

12. Other Commands and Functions	43
12.1 Read Manufacturer and Device ID (9Fh)	44
12.2 Read ID (Legacy Command) (90h)	45
12.3 Dual I/O Read Manufacture ID/ Device ID (92h)	46
12.4 Quad I/O Read Manufacture ID / Device ID (94h)	47
12.5 Deep Power-Down (B9h)	48
12.6 Resume from Deep Power-Down (ABh)	49
12.7 Hold Function	50
13. Electrical Specifications	51
13.1 Absolute Maximum Ratings	51
13.2 DC and AC Operating Range	51
13.3 DC Characteristics	51
13.4 AC Characteristics - Maximum Clock Frequencies	52
13.5 Program and Erase Characteristics	53
13.6 Power-Up Conditions	53
13.7 Input Test Waveforms and Measurement Levels	53
13.8 Output Test Load	54
14. AC Waveforms	54
15. Ordering Information	56
15.1 8-Pad, 150-mil Narrow JEDEC SOIC	57
15.2 8-Lead, 208-mil Wide EIAJ SOIC	58
15.3 8-Pad, 5 x 6 x 0.6 DFN	59
15.4 8-Ball 3 x 2 x 3 WLCSP	60
16. Revision History	61

Figures

Figure 1. 8-SOIC (0.150" and 0.208") — Top View	8
Figure 2. 8-ball WLCSP (3 x 2 x 3) — Bottom View	8
Figure 3. 8-DFN — Top View	8
Figure 4. Block Diagram	9
Figure 5. SPI Mode 0 and 3	12
Figure 6. Read Array - 03h Opcode	15
Figure 7. Read Array - 0Bh Opcode	15
Figure 8. Dual-Output Read Array	16
Figure 9. Dual I/O Read Array (Initial command or previous M5, M4 = 1,0)	17
Figure 10. Dual-I/O Read Array (Previous command set M5, M4 = 1,0)	18
Figure 11. Quad-Output Read Array	18
Figure 12. Quad-I/O Read Array (Initial command or previous M5, M4 = 1,0)	19
Figure 13. Quad I/O Read Array with Continuous Read Mode (Previous Command Set M5, M4 = 1,0)	20
Figure 14. Set Burst with Wrap Timing (SPI Mode)	21
Figure 15. Quad I/O Word Fast Read Timing (Initial Command Set M5, M4 ≠ 1,0) SPI Mode	22
Figure 16. Quad I/O Word Fast Read Timing (Previous Command Set M5, M4 = 1,0) SPI Mode	22
Figure 17. Read Serial Flash Discoverable Parameter Command Timing	23
Figure 18. Byte Program	24
Figure 19. Page Program Timing	25
Figure 20. Quad Page Program (32h) Timing	25
Figure 21. Block Erase	26
Figure 22. Erase/Program Suspend Timing	28
Figure 23. Enable Reset (66h) and Reset Device (99h) Command Timing (SPI Mode)	32
Figure 24. Read Unique ID Timing (SPI Mode)	33
Figure 25. Erase Security Register Page	34
Figure 26. Program Security Registers	35
Figure 27. Read Security Registers	36
Figure 28. Read Status Register 1	37
Figure 29. Read Status Register 2	38
Figure 30. Write Status Register	41
Figure 31. Write Enable for Volatile Status Register	42
Figure 32. Read Manufacturer and Device ID	44
Figure 33. Read ID (Legacy Command)	45
Figure 34. Dual I/O Read Manufacture ID/ Device ID Timing	46
Figure 35. Quad I/O Read Manufacture ID / Device ID Timing	47
Figure 36. Deep Power-Down	48
Figure 37. Resume from Deep Power-Down	49
Figure 38. Resume from Deep Power-Down and Read Device ID Timing	50
Figure 39. Power-Up Timing and Voltage	53
Figure 40. Serial Input Timing	54
Figure 41. Serial Output Timing	54
Figure 42. \overline{WP} Timing for Write Status Register Command When BPL = 1	55
Figure 43. \overline{HOLD} Timing – Serial Input	55
Figure 44. \overline{HOLD} Timing – Serial Output	55

Tables

Table 1. Pin Descriptions	7
Table 2. AT25SF161B Command Table	13
Table 3. Set Burst with Wrap Command Functions	21
Table 4. Memory Array with CMP = 0	30
Table 5. Memory Array Protection with CMP = 1	31
Table 6. Security Register Addresses for Erase Security Register Page Command	34
Table 7. Security Register Addresses for Program Security Registers Command	35
Table 8. Security Register Addresses for Read Security Registers Command	36
Table 9. Status Register 1 Bit Assignments	37
Table 10. Status Register 2 Bit Assignments	38
Table 11. Status Register 3 Bit Assignments	39
Table 12. Status Register Protection Table	39
Table 13. Write Status Register 1	41
Table 14. Write Status Register 2	41
Table 15. Write Status Register 3	41
Table 16. Manufacturer and Device ID Information	43
Table 17. Manufacturer and Device ID Information	44
Table 18. Manufacturer and Device ID Details	44

1. Product Overview

The AT25SF161B is a Serial Peripheral Interface (SPI) Flash memory device designed for use in a wide variety of high-volume industrial, consumer and connected applications.

It can be used for storing program memory that is booted from Flash memory into embedded or external RAM; it can also be used for directly executing the program code from the Flash memory (execute in place [XiP]).

XiP is specifically supported by features which enhance read speed:

- Quad-SPI, which allows reading four bits in one clock cycle.
- Continuous read mode (0-4-4 command format), which removes the need to send a command opcode.
- High SPI clock frequency.

These features allow fast response from the Flash memory whenever the host must fetch commands or data from it.

2. Pin Descriptions and Package Pinouts

Table 1. Pin Descriptions

Symbol	Name and Function	Assert State	Type
$\overline{\text{CS}}$	<p>CHIP SELECT</p> <p>Asserting the $\overline{\text{CS}}$ pin selects the device. When the $\overline{\text{CS}}$ pin is deasserted, the device is deselected and normally be placed in standby mode.</p> <p>A high-to-low transition on the $\overline{\text{CS}}$ pin is required to start an operation; a low-to-high transition is required to end an operation. When ending an internally self-timed operation, such as a program or erase cycle, the device does not enter the standby mode until the operation is complete.</p> <p>To ensure correct power-up sequencing, it is recommended to add a 10k Ohm pull-up resistor from $\overline{\text{CS}}$ to V_{CC}. This ensures $\overline{\text{CS}}$ ramps together with V_{CC} during power-up.</p>	Low	Input
SCK	<p>SERIAL CLOCK</p> <p>This pin provides a clock to the device. Command, address, and input data present on the SI pin is latched in on the rising edge of SCK, while output data on the SO pin is clocked out on the falling edge of SCK.</p>	-	Input
SI (I/O ₀)	<p>SERIAL INPUT</p> <p>The SI pin is used for all data input, including command and address sequences. Data on the SI pin is always latched in on the rising edge of SCK.</p> <p>With the Dual-Output and Quad-Output Read commands, the SI pin becomes an output pin (I/O₀) in conjunction with other pins to allow two or four bits of data (on I/O₃₋₀) to be clocked in on every falling edge of SCK.</p> <p>Data present on the SI pin is ignored whenever the device is deselected ($\overline{\text{CS}}$ is deasserted).</p>	-	Input/Output
SO (I/O ₁)	<p>SERIAL OUTPUT</p> <p>Data on the SO pin is clocked out on the falling edge of SCK.</p> <p>With the Dual-Output Read commands, the SO pin remains an output pin (I/O₀) in conjunction with other pins to allow two bits of data (on I/O₁₋₀) to be clocked in on every falling edge of SCK.</p> <p>The SO pin is in a high-impedance state whenever the device is deselected ($\overline{\text{CS}}$ is deasserted).</p>	-	Input/Output
$\overline{\text{WP}}$ (I/O ₂)	<p>WRITE PROTECT</p> <p>This pin is used either for write-protection, in which case it is referred to as $\overline{\text{WP}}$, or as one of the quad-SPI I/O pins, in which case it is referred to as IO₂.</p> <p>When the Quad Enable (QE) bit of Status Register 2 is 0, and the SRP1 and SRP0 bits are 0 and 1, respectively, the pin can be used for write-protection. It then can be asserted (driven low) to protect the Status Registers from modification.</p> <p>When the Quad Enable (QE) bit of Status Register 2 is 1, quad-SPI communication is enabled, and the pin is used as I/O pin IO₂ in any command that makes use of quad-SPI. In this setting, do not use the pin for write-protection.</p> <p>The $\overline{\text{WP}}$ pin is internally pulled-high and can be left floating if not used.</p>	-	Input/Output
$\overline{\text{HOLD}}$ (I/O ₃)	<p>HOLD</p> <p>This pin is used either for pausing communication, in which case it is referred to as $\overline{\text{HOLD}}$, or as one of the quad-SPI I/O pins, in which case it is referred to as IO₃.</p> <p>When the Quad Enable (QE) bit of Status Register 2 is 0, this pin is used as a $\overline{\text{HOLD}}$ pin.</p> <p>When the QE bit of Status Register 2 is 1, quad-SPI communication is enabled, and the pin is used as I/O pin IO₃ in any command that makes use of quad-SPI. In this setting, do not use the pin for pausing communication.</p> <p>The $\overline{\text{HOLD}}$ pin is used to pause a SPI sequence without resetting the clocking sequence. To enable the HOLD mode, the $\overline{\text{CS}}$ must be low. The HOLD mode effect is on with the falling edge of the $\overline{\text{HOLD}}$ signal with SCK being low. The HOLD mode ends on the rising edge of $\overline{\text{HOLD}}$ signal with SCK being low.</p> <p>The $\overline{\text{HOLD}}$/IO₃ pin is internally pulled-high and can be left floating if not used.</p>	-	Input/Output
V_{CC}	<p>DEVICE POWER SUPPLY</p> <p>The V_{CC} pin supplies the source voltage to the device.</p>	-	Power

Table 1. Pin Descriptions (Continued)

Symbol	Name and Function	Assert State	Type
GND	GROUND The ground reference for the power supply. Connect GND to the system ground.	-	Power

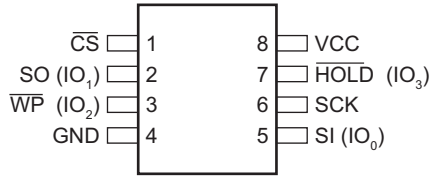

Figure 1. 8-SOIC (0.150" and 0.208") — Top View

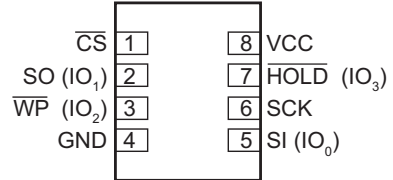

Figure 3. 8-DFN — Top View

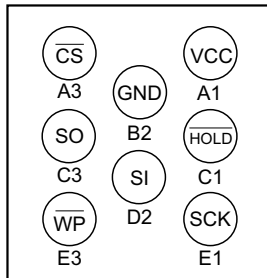
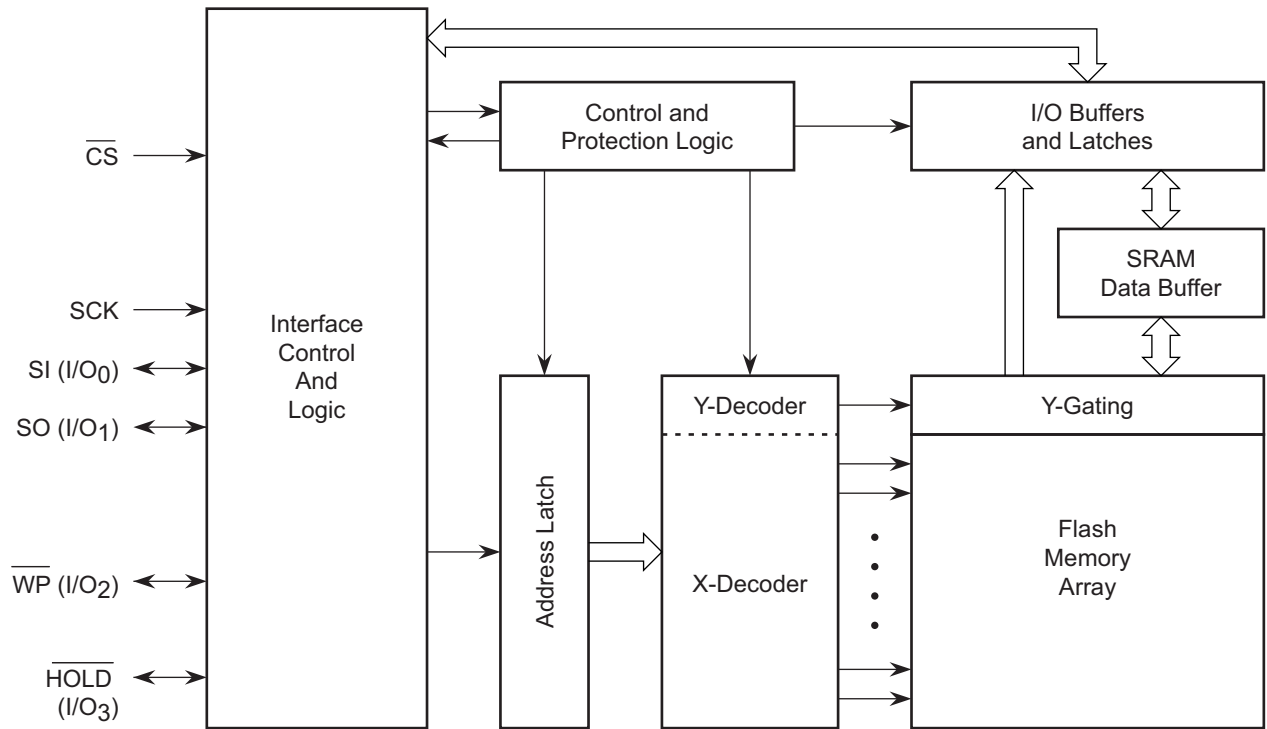

Figure 2. 8-ball WLCSP (3 x 2 x 3) — Bottom View

3. Block Diagram



Note: I/O₃₋₀ pin naming convention is used for Dual-I/O and Quad-I/O commands.

Figure 4. Block Diagram

4. Memory Array

To provide the greatest flexibility, the memory array of the AT25SF161B can be erased in four levels of granularity, including a full-chip erase. The size of the erase blocks is optimized for both code and data storage applications, allowing both code and data segments to reside in their own erase regions. Note that in the following figures, the (Bxxx) value in parentheses indicates the block number.

The physical block size of this device is 4 Mbit.

64 kbyte Block Erase (D8h)	32 kbyte Block Erase (52h)	4 kbyte Block Erase (20h)	Block Address Range
64 kbytes (block 31)	32 kbytes (block 63)	4 kbytes (B511)	1FF000h - 1FFFFFFh
		4 kbytes (B510)	1FE000h - 1FEFFFh
		4 kbytes (B509)	1FD000h - 1FDFFFh
		4 kbytes (B508)	1FC000h - 1FCFFFh
		4 kbytes (B507)	1FB000h - 1FBFFFh
		4 kbytes (B506)	1FA000h - 1FAFFFh
		4 kbytes (B505)	1F9000h - 1F9FFFh
		4 kbytes (B504)	1F8000h - 1F8FFFh
	32 kbytes (block 62)	4 kbytes (B503)	1F7000h - 1F7FFFh
		4 kbytes (B502)	1F6000h - 1F6FFFh
		4 kbytes (B501)	1F5000h - 1F5FFFh
		4 kbytes (B500)	1F4000h - 1F4FFFh
		4 kbytes (B499)	1F3000h - 1F3FFFh
		4 kbytes (B498)	1F2000h - 1F2FFFh
		4 kbytes (B497)	1F1000h - 1F1FFFh
		4 kbytes (B496)	1F0000h - 1F0FFFh
64 kbytes (block 30) to 64 kbytes (block 1)	32 kbytes (block 61) to 32 kbytes (block 2)	4 kbytes (B495) to 4 kbytes (B16)	1EF000h - 1EFFFFh to 010000h - 010FFFh
64 kbytes (block 0)	32 kbytes (block 1)	4 kbytes (B15)	00F000h - 00FFFFh
		4 kbytes (B14)	00E000h - 00EFFFh
		4 kbytes (B13)	00D000h - 00DFFFh
		4 kbytes (B12)	00C000h - 00CFFFh
		4 kbytes (B11)	00B000h - 00BFFFh
		4 kbytes (B10)	00A000h - 00AFFFh
		4 kbytes (B9)	009000h - 009FFFh
		4 kbytes (B8)	008000h - 008FFFh
	32 kbytes (block 0)	4 kbytes (B7)	007000h - 007FFFh
		4 kbytes (B6)	006000h - 006FFFh
		4 kbytes (B5)	005000h - 005FFFh
		4 kbytes (B4)	004000h - 004FFFh
		4 kbytes (B3)	003000h - 003FFFh
		4 kbytes (B2)	002000h - 002FFFh
		4 kbytes (B1)	001000h - 001FFFh
		4 kbytes (B0)	000000h - 000FFFh

4 kbytes Blocks	256 Byte Page	1 - 256 Byte Page Program
4 kbytes (B511)	256 Bytes	1FFF00h - 1FFFFFh
4 kbytes (B510)	256 Bytes	1FFE00h - 1FFEFFh
4 kbytes (B509)	256 Bytes	1FFD00h - 1FFDFFh
4 kbytes (B508)	256 Bytes	1FFC00h - 1FFCFFh
4 kbytes (B507)	256 Bytes	1FFB00h - 1FFBFFh
4 kbytes (B506)	256 Bytes	1FFA00h - 1FFAFFh
4 kbytes (B505)	256 Bytes	1FF900h - 1FF9FFh
4 kbytes (B504)	256 Bytes	1FF800h - 1FF8FFh
4 kbytes (B503)	256 Bytes	1FF700h - 1FF7FFh
4 kbytes (B502)	256 Bytes	1FF600h - 1FF6FFh
4 kbytes (B501)	256 Bytes	1FF500h - 1FF5FFh
4 kbytes (B500)	256 Bytes	1FF400h - 1FF4FFh
4 kbytes (B499)	256 Bytes	1FF300h - 1FF3FFh
4 kbytes (B498)	256 Bytes	1FF200h - 1FF2FFh
4 kbytes (B497)	256 Bytes	1FF100h - 1FF1FFh
4 kbytes (B496)	256 Bytes	1FF000h - 1FF0FFh
4 kbytes (B494) to 4 kbytes (B16)	.	.
4 kbytes (B15)	256 Bytes	000F00h - 000FFFh
4 kbytes (B14)	256 Bytes	000E00h - 000EFFh
4 kbytes (B13)	256 Bytes	000D00h - 000DFFh
4 kbytes (B12)	256 Bytes	000C00h - 000CFFh
4 kbytes (B11)	256 Bytes	000B00h - 000BFFh
4 kbytes (B10)	256 Bytes	000A00h - 000AFFh
4 kbytes (B9)	256 Bytes	000900h - 0009FFh
4 kbytes (B8)	256 Bytes	000800h - 0008FFh
4 kbytes (B7)	256 Bytes	000700h - 0007FFh
4 kbytes (B6)	256 Bytes	000600h - 0006FFh
4 kbytes (B5)	256 Bytes	000500h - 0005FFh
4 kbytes (B4)	256 Bytes	000400h - 0004FFh
4 kbytes (B3)	256 Bytes	000300h - 0003FFh
4 kbytes (B2)	256 Bytes	000200h - 0002FFh
4 kbytes (B1)	256 Bytes	000100h - 0001FFh
4 kbytes (B0)	256 Bytes	000000h - 0000FFh

5. Device Operation

The AT25SF161B is controlled by a set of commands sent from a host controller, SPI Master. The SPI Master communicates with the AT25SF161B through the SPI bus, which consists of four pins: Chip Select (\overline{CS}), Serial Clock (SCK), Serial Input (SI), and Serial Output (SO).

The SPI protocol defines a total of four modes of operation (mode 0, 1, 2, or 3). The AT25SF161B supports the two most common modes, SPI modes 0 and 3. For these modes, data is latched in on the rising edge of SCK and output on the falling edge of SCK.

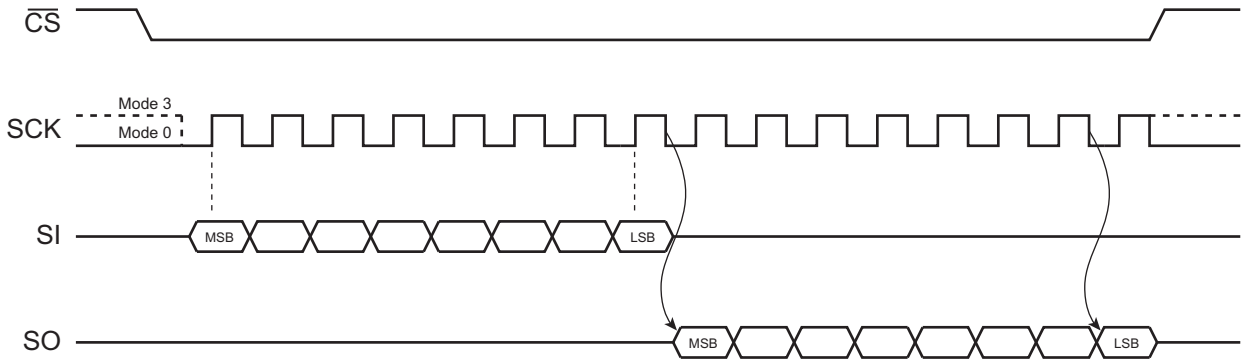

Figure 5. SPI Mode 0 and 3

5.1 Dual Output Read (1-1-2)

The AT25SF161B supports Dual Output (1-1-2) transfers, which enhance overall throughput over the standard SPI mode. This mode transfers the command and address on the SI pin, but the data are transferred on the SI and SO pins. This means that only half the number of clocks are required to transfer the data.

5.2 Dual I/O Read (1-2-2)

The AT25SF161B supports Dual I/O (1-2-2) transfers, which enhance throughput over the standard SPI mode. This mode transfers the command on the SI pin, but the address and data are transferred on the SI and SO pins. This means that only half the number of clocks are required to transfer the address and data.

5.3 Quad Output Read (1-1-4)

The AT25SF161B supports Quad Output (1-1-4) transfers, which enhance overall throughput over the standard SPI mode. This mode transfers the command and address on the SI pin, but the data is transferred on the SI, SO, \overline{WP} , and \overline{HOLD} pins. This means that only a quarter the number of clocks are required to transfer the data. With the Quad-Output Read Array command, the SI, \overline{WP} , and \overline{HOLD} pins become outputs along with the SO pin.

5.4 Quad I/O Read (1-4-4)

The AT25SF161B supports Quad I/O (1-4-4) transfers, which enhance throughput over the standard SPI mode. This mode transfers the command on the SI pin, but the address and data are transferred on the SI, SO, \overline{WP} , and \overline{HOLD} pins. This means that only a quarter of the number of clocks are required to transfer the address and data. With the Quad I/O Read Array command, the SI, \overline{WP} , and \overline{HOLD} and SO pins become inputs during the address transfer, and switch to outputs during the data transfer.

6. Commands and Addressing

A valid command or operation must be started by first asserting the \overline{CS} pin. After the \overline{CS} pin has been asserted, the host controller must clock out a valid eight-bit opcode on the SPI bus. Following the opcode, command-dependent information, such as address and data bytes, can be clocked out by the host controller. All opcode, address, and data bytes are transferred with the most-significant bit (MSB) first. An operation is ended by deasserting the \overline{CS} pin.

Opcodes not supported by the AT25SF161B are ignored by the device, and no operation is started. The device continues to ignore any data presented on the SI pin until the start of the next operation (\overline{CS} pin being deasserted and then reasserted). If the \overline{CS} pin is deasserted before complete opcode, and address information is sent to the device, no operation is performed, and the device returns to the idle state and waits for the next operation.

Addressing of the device requires three bytes of information to be sent, representing address bits A23-A0. Since the upper address limit of the AT25SF161B memory array is 1FFFFh, address bits A23-A21 are ignored by the device.

Table 2. AT25SF161B Command Table

Command Name	Command Opcode	Bus Transfer Type (OP-AD-DA) ¹	Mode Bit Present	Mode Bit Clocks	Wait Cycle Dummy Clocks	Data Bytes
System Commands						
Enable Reset	66h	1-0-0	N	0	0	0
Reset Device	99h	1-0-0	N	0	0	0
Deep Power-down	B9h	1-0-0	N	0	0	0
Release Power-down	ABh	1-0-0	N	0	0	0
Read Commands						
Normal Read Data	03h	1-1-1	N	0	0	1+
Fast Read	0Bh	1-1-1	N	0	8	1+
Dual Output Fast read	3Bh	1-1-2	N	0	8	1+
Dual I/O Fast read	BBh	1-2-2	Y	4	0	1+
Dual I/O Fast read (Continuous Mode)	BBh	0-2-2	Y	4	0	1+
Quad Output Fast read	6Bh	1-1-4	N	0	8	1+
Quad I/O Fast read	EBh	1-4-4	Y	2	4	1+
Quad I/O Fast read (Continuous Mode)	EBh	0-4-4	Y	2	4	1+
Word Read Quad I/O	E7h	1-4-4	Y	2	2	1+
Word Read Quad I/O (Continuous Mode)	E7h	0-4-4	Y	2	2	1+
Set Burst With Wrap	77h	1-0-4	N	0	6	1, D[6:4]
Write Commands						
Write Enable	06h	1-0-0	N	0	0	0
Volatile SR Write Enable	50h	1-0-0	N	0	0	0
Write Disable	04h	1-0-0	N	0	0	0

Table 2. AT25SF161B Command Table (Continued)

Command Name	Command Opcode	Bus Transfer Type (OP-AD-DA) ¹	Mode Bit Present	Mode Bit Clocks	Wait Cycle Dummy Clocks	Data Bytes
Program Commands						
Page Program	02h	1-1-1	N	0	0	1+
Quad Page Program	32h	1-1-4	N	0	0	1+
Erase Commands						
Block Erase (4KB)	20h	1-1-0	N	0	0	0
Block Erase (32KB)	52h	1-1-0	N	0	0	0
Block Erase (64KB)	D8h	1-1-0	N	0	0	0
Chip Erase	C7h/60h	1-0-0	N	0	0	0
Suspend/Resume Commands						
Program/Erase Suspend	75h	1-0-0	N	0	0	0
Program/Erase Resume	7Ah	1-0-0	N	0	0	0
Status Register Commands						
Read Status Register 1	05h	1-0-1	N	0	0	1
Read Status Register 2	35h	1-0-1	N	0	0	1
Read Status Register 3	15h	1-0-1	N	0	0	1
Write Status Register 1	01h	1-0-1	N	0	0	1
Write Status Register 2	31h	1-0-1	N	0	0	1
Write Status Register 3	11h	1-0-1	N	0	0	1
Device Information Commands						
Manufacturer/Device ID	90h	1-1-1	N	0	0	2
Mfgr./Device ID Dual I/O	92h	1-2-2	N	0	4	2
Mfgr./Device ID Quad I/O	94h	1-4-4	N	0	4	2
Read JEDEC ID	9Fh	1-0-1	N	0	0	3
Read Serial Flash Discoverable Parameter	5Ah	1-1-1	N	0	8	1+
OTP Commands						
Erase Security Registers	44h	1-1-0	N	0	0	0
Program Security Registers	42h	1-1-1	N	0	0	1+
Read Security Registers	48h	1-1-1	N	0	8	1+
Read Unique ID Number	4Bh	1-0-1	N	0	32	1+

1. OP = Opcode (command number), AD = Address. DA = Data. 0 indicates the corresponding transfer does not occur in that command. 1 indicates the transfer does occur. For example, 1-0-0 indicates a command transfer occurs, but no address or data transfers occur.
 Op: Opcode or Commands (8-bits): 0 → No Opcode [continuous Read], 1 → 8 clocks for Opcode, 2 → 4 clocks for Opcode, 4 → 2 clocks for opcode.
 AD: Address (24-bits) Only: 0 → No address, Opcode only operation, 1 → 24 clocks for Address, 2 → 12 clocks for address, 4 → 6 clocks for address.
 AD: Address (24-bits) + Mode (8-bits): 2 → 12 clocks for address, 4 clocks for mode [BBh only], 4 → 6 clocks for address, 2 clocks for mode [EBh and E7h].
 DA: Data(8-bits): 1 → 8 clocks for Byte, 2 → 4 clocks for Byte, 4 → 2 clocks for Byte.

7. Read Commands

7.1 Read Array (0Bh and 03h)

The Read Array command can be used to sequentially read a continuous stream of data from the device by providing the clock pin once the initial starting address is specified. The device incorporates an internal address counter that automatically increments every clock cycle.

To perform the Read Array operation, the \overline{CS} pin first must be asserted, and the appropriate opcode (0Bh or 03h) must be clocked into the device. After the opcode has been clocked in, the three address bytes must be clocked in to specify the starting address location of the first byte to read within the memory array. If the 0Bh opcode is used for the Read Array operation, an additional dummy byte must be clocked into the device after the three address bytes.

After the three address bytes (and the dummy byte, if using opcode 0Bh) have been clocked in, additional clock cycles result in data being output on the SO pin. The data is always output with the MSB of a byte first. When the last byte (1FFFFFFh) of the memory array has been read, the device continues reading back at the beginning of the array (000000h). No delays are incurred when wrapping around from the end of the array to the beginning of the array.

Deasserting the \overline{CS} pin terminates the read operation and puts the SO pin into high-impedance state. The \overline{CS} pin can be deasserted at any time and does not require a full byte of data be read.

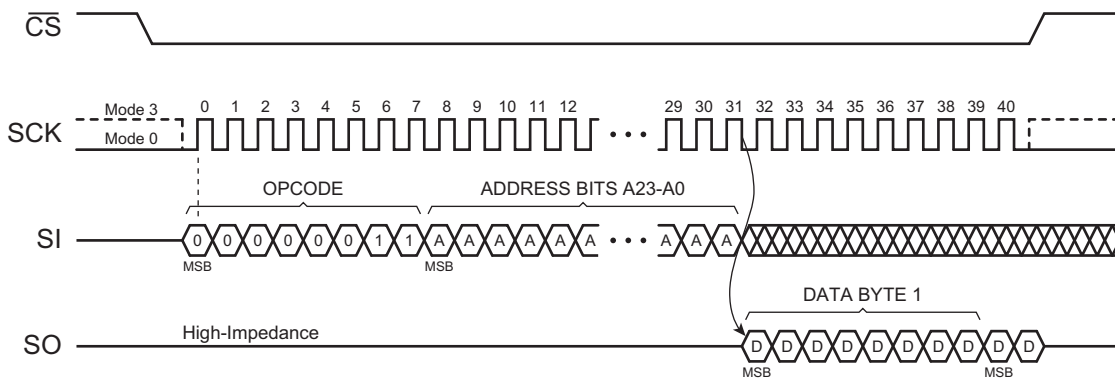

Figure 6. Read Array - 03h Opcode

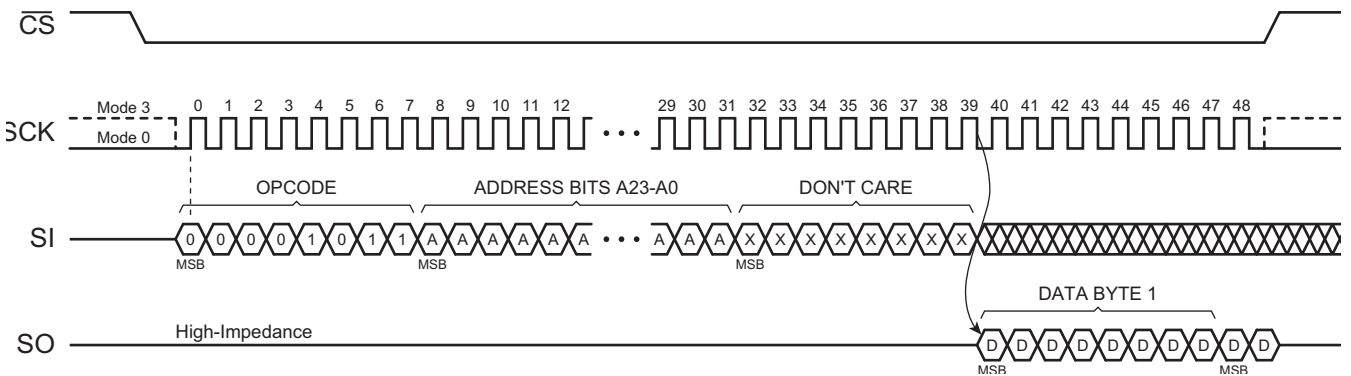

Figure 7. Read Array - 0Bh Opcode

7.2 Dual-Output Read Array (3Bh)

The Dual-Output Read Array command is similar to the standard Read Array command; it can be used to sequentially read a continuous stream of data from the device by providing the clock pin once the initial starting address has been specified. Unlike the standard Read Array command, the Dual-Output Read Array command allows two bits of data to be clocked out of the device on every clock cycle, rather than just one.

To perform the Dual-Output Read Array operation, the \overline{CS} pin must first be asserted; then, the opcode 3Bh must be clocked into the device. After the opcode has been clocked in, the three address bytes must be clocked in to specify the location of the first byte to read within the memory array. Following the three address bytes, a single dummy byte also must be clocked into the device.

After the three address bytes and the dummy byte have been clocked in, additional clock cycles output data on both the SO and SI pins. The data is output with the MSB of a byte first, and the MSB is output on the SO pin. During the first clock cycle, bit seven of the first data byte is output on the SO pin, while bit six of the same data byte is output on the SI pin. During the next clock cycle, bits five and four of the first data byte are output on the SO and SI pins, respectively. The sequence continues with each byte of data being output after every four clock cycles. When the last byte (1FFFFFFh) of the memory array has been read, the device continues reading from the beginning of the array (000000h). There are no delays because of wrapping around from the end of the array to the beginning of the array. Deasserting the \overline{CS} pin terminates the read operation and puts the SO and SI pins into a high-impedance state. The \overline{CS} pin can be deasserted at any time and does not require that a full byte of data be read.

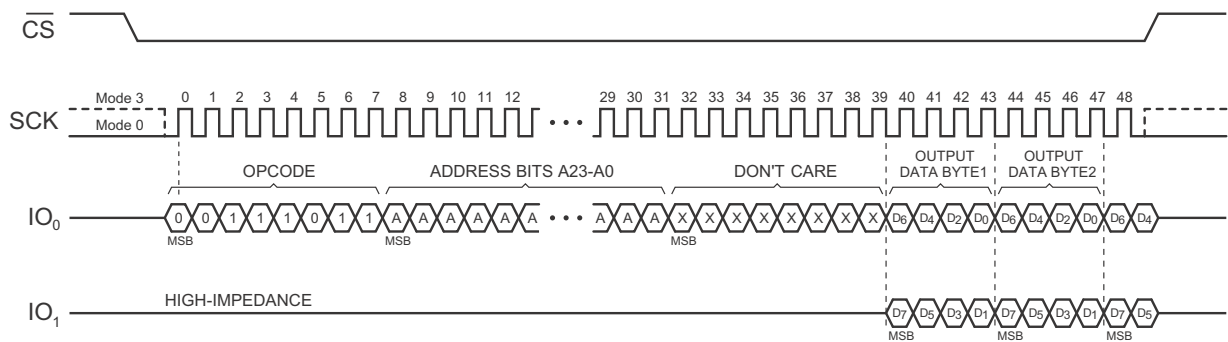

Figure 8. Dual-Output Read Array

7.3 Dual-I/O Read Array (BBh)

The Dual-I/O Read Array command is similar to the Dual-Output Read Array command and can be used to sequentially read a continuous stream of data from the device by providing the clock pin once the initial starting address with two bits of address on each clock and two bits of data on every clock cycle.

To perform the Dual-I/O Read Array operation, the \overline{CS} pin must first be asserted; then, the opcode BBh must be clocked into the device. After the opcode has been clocked in, the three address bytes must be clocked in to specify the location of the first byte to read within the memory array. Following the three address bytes, a single mode byte also must be clocked into the device.

After the three address bytes and the mode byte have been clocked in, additional clock cycles output data on both the SO and SI pins. The data is always output with the MSB of a byte first, and the MSB is always output on the SO pin. During the first clock cycle, bit seven of the first data byte is output on the SO pin, while bit six of the same data byte is output on the SI pin. During the next clock cycle, bits five and four of the first data byte are output on the SO and SI pins, respectively. The sequence continues with each byte of data output after every four clock cycles. When the last byte (1FFFFFFh) of the memory array has been read, the device continues reading from the beginning of the array (000000h). No delays are incurred when wrapping around from the end of the array to the beginning of the array. Deasserting the \overline{CS} pin terminates the read operation and puts the SO and SI pins into a high-impedance state. The \overline{CS} pin can be deasserted at any time and does not require that a full byte of data be read.

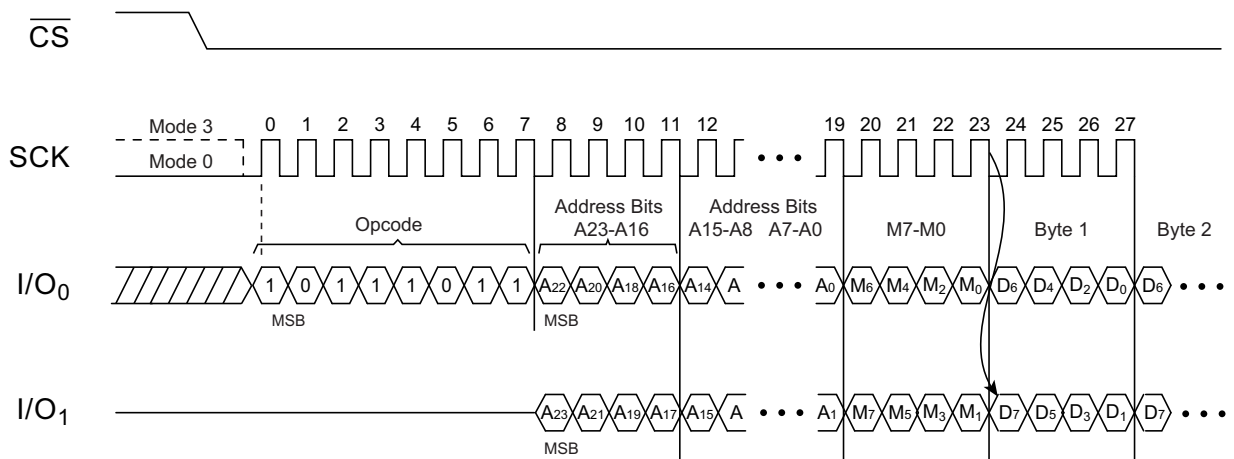

Figure 9. Dual I/O Read Array (Initial command or previous M₅,M₄ ≠ 1,0)

7.3.1 Dual-I/O Read Array (BBh) with Continuous Read Mode

The Fast Read Dual I/O command can further reduce command overhead through setting the Continuous Read Mode bits (M7-0) after the input Address bits (A23-0), as shown in Figure 10. The upper nibble of M7-4 controls the length of the next Fast Read Dual I/O command through the inclusion, or exclusion, of the first byte command code. The lower nibble bits of M3-0 are don't care (x). However, the I/O pins must be high-impedance prior to the falling edge of the first data out clock. If the Continuous Read Mode bits M5-4 = (1,0), the next Fast Read Dual I/O command (after \overline{CS} is raised and then lowered) does not require the BBh command code. This reduces the command sequence by eight clocks and allows the Read address to be immediately entered after \overline{CS} is asserted low. If the Continuous Read Mode bits M5-4 do not equal to (1,0), the next command (after \overline{CS} is raised and then lowered) requires the first byte command code, thus returning to normal operation. A Continuous Read Mode Reset command can also be used to reset M7-0 before issuing normal commands.

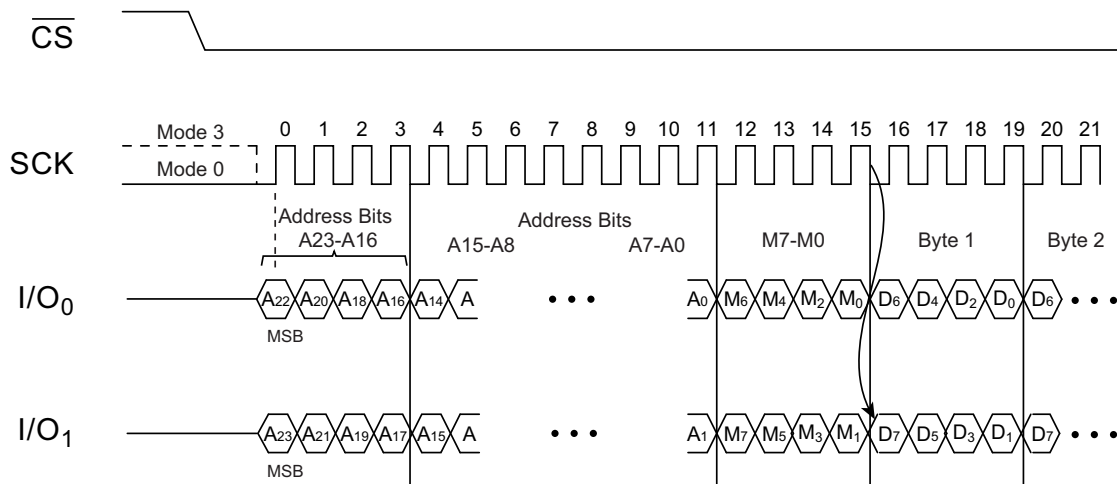

Figure 10. Dual-I/O Read Array (Previous command set M5, M4 = 1,0)

7.4 Quad Output Fast Read Array (6Bh)

The Quad-Output Read Array command is followed by a three-byte address (A23 - A0) and one dummy byte, each bit being latched in during the rising edge of SCK; then, the memory contents are shifted out four bits per clock cycle from I/O₃, I/O₂, I/O₁, and I/O₀. The first byte addressed can be at any location. The address automatically increments to the next higher address after each byte of data is shifted out.

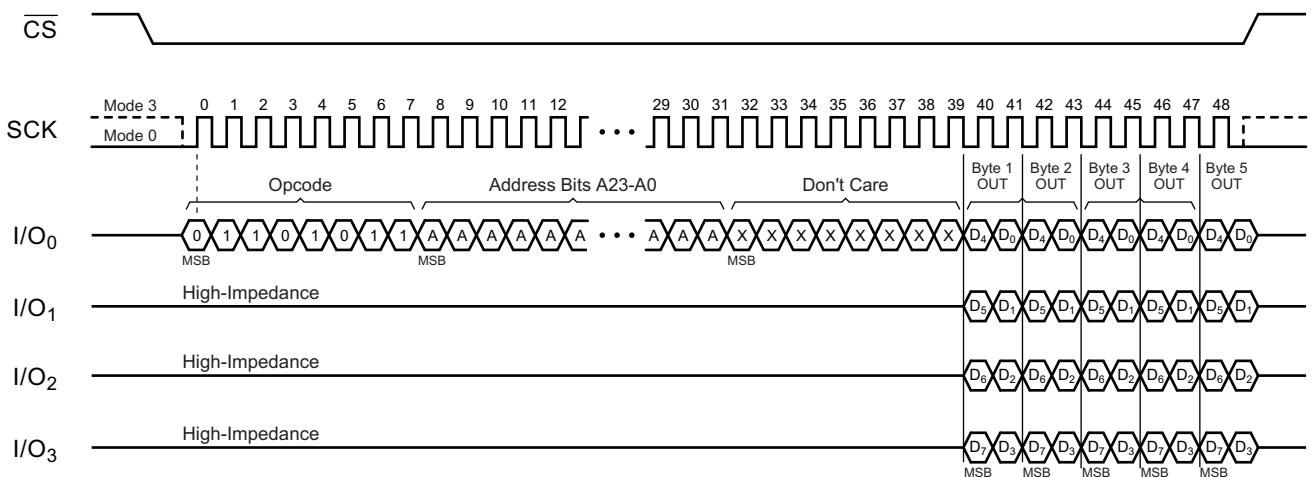

Figure 11. Quad-Output Read Array

7.5 Quad-I/O Read Array (EBh)

The Quad-I/O Read Array command is similar to the Quad-Output Read Array command. It allows four bits of address to be clocked into the device on every clock cycle, rather than just one.

To perform the Quad-I/O Read Array operation, the \overline{CS} pin must first be asserted; then, the opcode EBh must be clocked into the device. After the opcode has been clocked in, the three address bytes must be clocked in to specify the location of the first byte to read within the memory array. Following the three address bytes, a single mode byte must also be clocked into the device.

After the three address bytes, the mode byte and two dummy bytes have been clocked in, additional clock cycles output data on the I/O₃₋₀ pins. The data is output with the MSB of a byte first, and the MSB is output on the I/O₃ pin. During the first clock cycle, bit 7 of the first data byte is output on the I/O₃ pin while bits 6, 5, and 4 of the same data byte are output on the I/O₂, I/O₁, and I/O₀ pins, respectively. During the next clock cycle, bits 3, 2, 1, and 0 of the first data byte are output on the I/O₃, I/O₂, I/O₁ and I/O₀ pins, respectively. The sequence continues with each byte of data being output after every two clock cycles.

When the last byte (1FFFFFFh) of the memory array has been read, the device continues reading from the beginning of the array (000000h). No delays are incurred when wrapping around from the end of the array to the beginning of the array. Deasserting the \overline{CS} pin terminates the read operation and puts the I/O₃, I/O₂, I/O₁, and I/O₀ pins into a high-impedance state. The \overline{CS} pin can be deasserted at any time and does not require a full byte of data to be read. The Quad Enable bit (QE) of the Status Register must be set to enable for the Quad-I/O Read Array command.

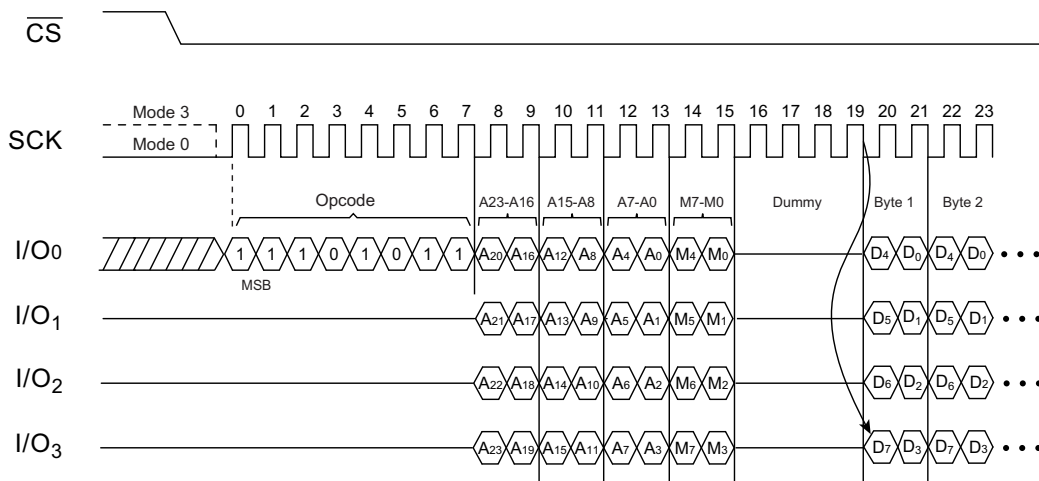

Figure 12. Quad-I/O Read Array (Initial command or previous M5, M4 ≠ 1,0)

7.5.1 Quad-I/O Read Array (EBh) with Continuous Read Mode

The Read Quad I/O command can further reduce command overhead through setting the Continuous Read Mode bits (M7-0) after the input Address bits (A23-0), as shown in Figure 12. The upper nibble (M7-4) of the Continuous Read Mode bits controls the length of the next Fast Read Quad I/O command through the inclusion, or exclusion, of the first byte command code. The lower nibble bits (M3-0) of the Continuous Read Mode bits are don't care. However, the IO pins must be high-impedance prior to the falling edge of the first data out clock. If the Continuous Read Mode bits M5-4 = (1,0), the next Quad-I/O Read Array command (after \overline{CS} is raised and then lowered) does not require the EBh command code, as shown in Figure 13. This reduces the command sequence by eight clocks and allows the Read address to be immediately entered after \overline{CS} is asserted low. If the *Continuous Read Mode* bits M5-4 do not equal to (1,0), the next command (after \overline{CS} is raised and then lowered) requires the first byte command code, thus returning to normal operation. A Continuous Read Mode Reset command can also be used to reset M7-0 before issuing normal commands.

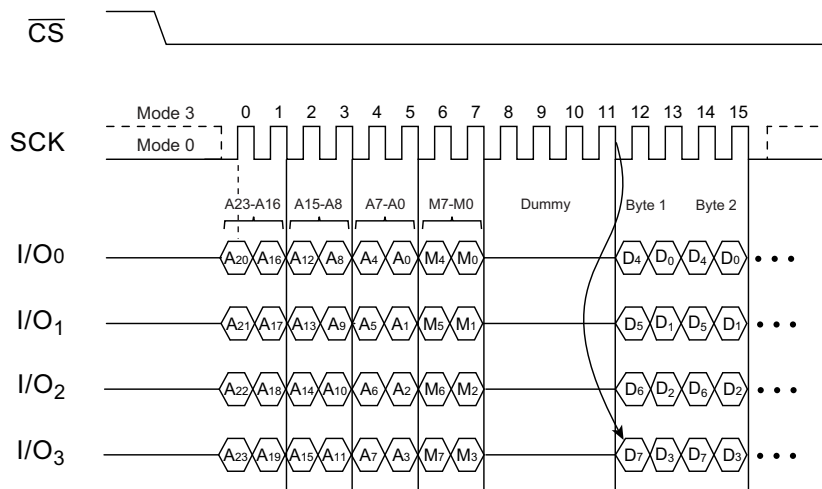

Figure 13. Quad I/O Read Array with Continuous Read Mode (Previous Command Set M5, M4 = 1,0)

7.5.2 Set Burst with Wrap (77h)

The Set Burst with Wrap command is used in conjunction with the Quad I/O Fast Read and Quad I/O Word Fast Read command to access a fixed length (8-, 16-, 32-, or 64-byte) section within a 256-byte page in standard SPI mode (see Table 3 and Figure 14).

Table 3. Set Burst with Wrap Command Functions

W6, W5	W4 = 0		W4 = 1 (Default)	
	Wrap Around	Wrap Length	Wrap Around	Wrap Length
0 0	Yes	8 bytes	No	N/A
0 1	Yes	16 bytes	No	N/A
1 0	Yes	32 bytes	No	N/A
1 1	Yes	64 bytes	No	N/A

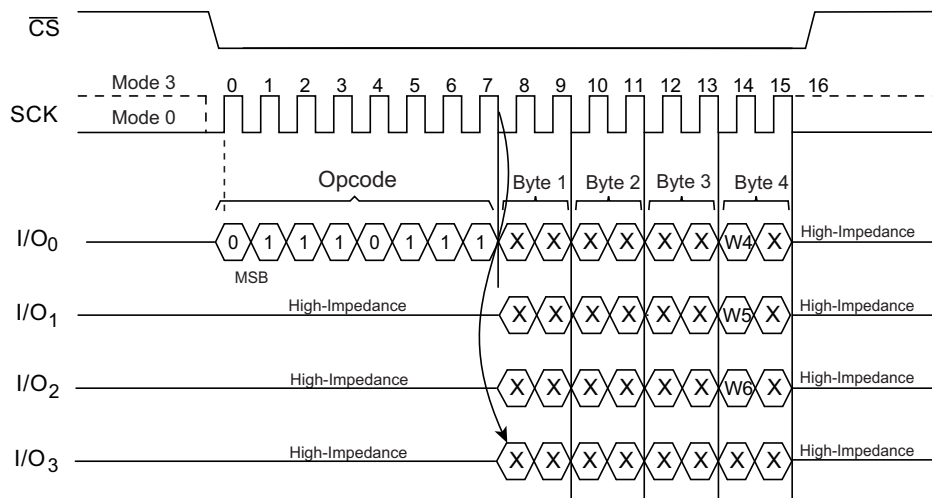

Figure 14. Set Burst with Wrap Timing (SPI Mode)

The Set Burst with Wrap command sequence is: \overline{CS} goes low → Send Set Burst with Wrap command → Send 24 Dummy bits → Send 8 Wrap bits → \overline{CS} goes high.

If W6-4 is set by a Set Burst with Wrap command, all the following Fast Read Quad I/O and Word Read Quad I/O commands use the W6-4 setting to access the 8-, 16-, 32-, or 64-byte section within any page. To exit the Wrap Around function and return to normal read operation, issue another Set Burst with Wrap command to set W4=1. The default value of W4 at power-on is 1.

7.6 Quad-I/O Word Fast Read (E7h)

The Quad I/O Word Fast Read command is similar to the Quad Fast Read command, except that the lowest address bit (A0) must equal 0 and have two dummy clock cycles. Figure 15 shows the command sequence; the first byte addressed can be at any location. The address is automatically incremented to the next higher address after each byte of data is shifted out. The Quad Enable bit (QE) of the Status Register (S9) must be set to enable.

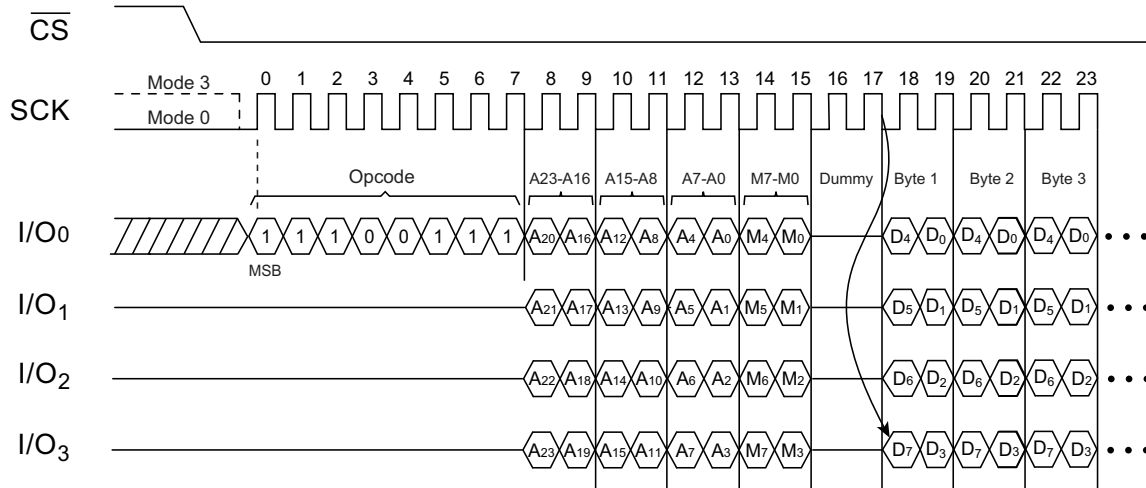

Figure 15. Quad I/O Word Fast Read Timing (Initial Command Set M5, M4 ≠ 1,0) SPI Mode

7.6.1 Quad I/O Word Fast Read with Continuous Read Mode

The Quad I/O Word Fast Read command can further reduce command overhead by setting the Continuous Read Mode bits (M7-0) after input of the Address bits (A23-0). If the Continuous Read Mode bits (M5-4) = (1, 0), the next Quad I/O Fast Read command (after \overline{CS} is raised and then lowered) does not require the E7h command code. Figure 16 shows the command sequence. If the Continuous Read Mode bits M5-4 do not equal to (1,0), the next command requires the first E7h command code, thus returning to normal operation. A Continuous Read Mode Reset command also can be used to reset (M5-4) before issuing normal command.

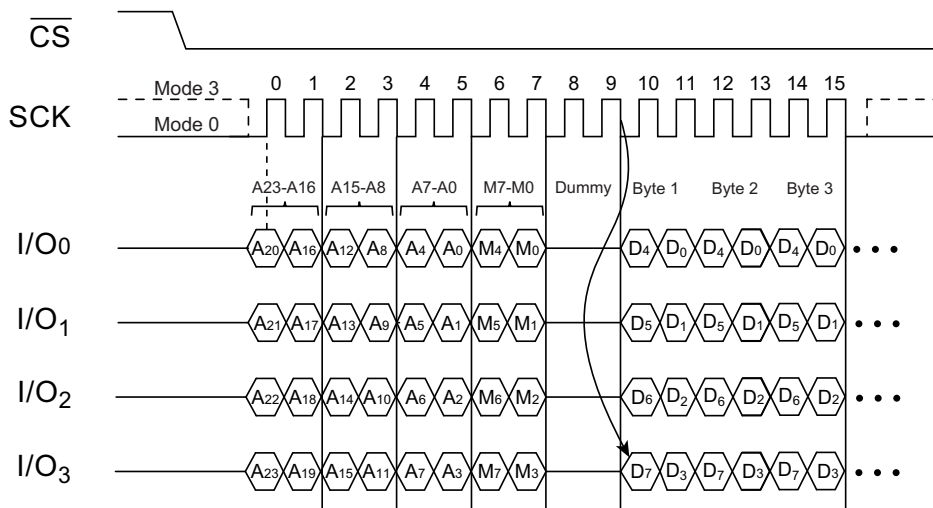

Figure 16. Quad I/O Word Fast Read Timing (Previous Command Set M5, M4 = 1,0) SPI Mode

7.6.2 Quad I/O Word Fast Read with 8-, 16-, 32-, 64-Byte Wrap Around in Standard SPI Mode

The Quad I/O Fast Read command also can be used to access a specific portion within a page by issuing a Set Burst with Wrap (77h) command prior to E7h. The Set Burst with Wrap (77h) command can enable or disable the Wrap Around feature for the following E7h commands. When enabled, the data accessed can be limited to an 8-,

16-, 32-, or 64-byte section of a 256-byte page. The output data starts at the initial address specified in the command when it reaches the ending boundary of the 8-, 16-, 32-, or 64-byte section. The output wraps around to the beginning boundary automatically until \overline{CS} is pulled high to terminate the command.

The Burst with Wrap feature allows applications that use cache to quickly fetch a critical address and then fill the cache afterwards within a fixed length (8-, 16-, 32-, or 64-bytes) of data without issuing multiple read commands.

The Set Burst with Wrap command allows three Wrap Bits (W6-4) to be set. W4 enables or disables the wrap around operation; W5 specifies the length of the wrap around section within a page.

7.7 Read Serial Flash Discoverable Parameter (5Ah)

The Serial Flash Discoverable Parameter (SFDP) standard provides a consistent method of describing the functional and feature capabilities of serial Flash devices in a standard set of internal parameter tables. These parameter tables can be interrogated by host system software to enable adjustments needed to accommodate divergent features from multiple vendors. SFDP is a JEDEC Standard, JESD216D. For more detailed SFDP values, contact Renesas Electronics.

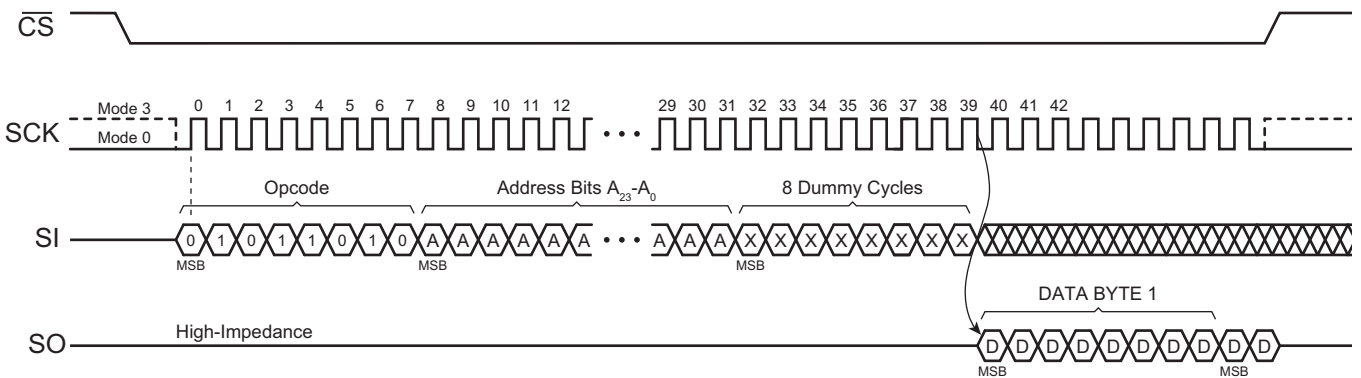

Figure 17. Read Serial Flash Discoverable Parameter Command Timing

8. Program and Erase Commands

8.1 Byte/Page Program (02h)

The Byte/Page Program command allows one to 256 bytes of data to be programmed into previously erased memory locations. An erased memory location is one that has all eight bits set to the logical 1 state (a byte value of FFh). Before a Byte/Page Program command can be started, the Write Enable command must have been issued to the device (see Section 9.1) to set the Write Enable Latch (WEL) bit of the Status Register to a logical 1 state.

To perform a Byte/Page Program command, an opcode of 02h must be clocked into the device, followed by the three address bytes denoting the first byte location of the memory array to begin programming at. After the address bytes have been clocked in, data can then be clocked into the device and is stored in an internal buffer.

If the starting memory address denoted by A23-A0 does not fall on an even 256-byte page boundary (A7-A0 are not all 0), special circumstances regarding which memory locations to be programmed apply. In this situation, any data that is sent to the device that goes beyond the end of the page wraps around back to the beginning of the same page. For example, if the starting address denoted by A23-A0 is 0000FEh, and three bytes of data are sent to the device, the first two bytes of data are programmed at addresses 0000FEh and 0000FFh, and the last byte of data is programmed at address 000000h. The remaining bytes in the page (addresses 000001h through 0000FDh) are not programmed and remain in the erased state (FFh). Also, if more than 256 bytes of data are sent to the device, only the last 256 bytes sent are latched into the internal buffer.

When the \overline{CS} pin is deasserted, the device takes the data stored in the internal buffer and programs it into the appropriate memory array locations based on the starting address specified by A23-A0 and the number of data bytes sent to the device. If fewer than 256 bytes of data were sent to the device, the remaining bytes within the page are not programmed and remain in the erased state (FFh). The programming of the data bytes is internally self-timed and, if only programming a single byte, must take place in a time of t_{PP} or t_{BP} .

The three address bytes and at least one complete data byte must be clocked into the device before the \overline{CS} pin is deasserted, and the \overline{CS} pin must be deasserted on even byte boundaries (multiples of eight bits); otherwise, the device aborts the operation and no data is programmed into the memory array. Also, if the memory is in the protected state, the Byte/Page Program command is not executed, and the device returns to the idle state once the \overline{CS} pin has been deasserted. The WEL bit in the Status Register is reset to the logical 0 state if: the program cycle aborts due to an incomplete address being sent, an incomplete byte of data is sent, the \overline{CS} pin is deasserted on uneven byte boundaries, or the memory location to be programmed is protected.

While the device is programming, the Status Register can be read and indicates that the device is busy. For faster throughput, it is recommended that the Status Register be polled, rather than waiting the t_{BP} or t_{PP} time to determine if the data bytes have finished programming. At some point before the program cycle completes, the WEL bit in the Status Register is reset to the logical 0 state.

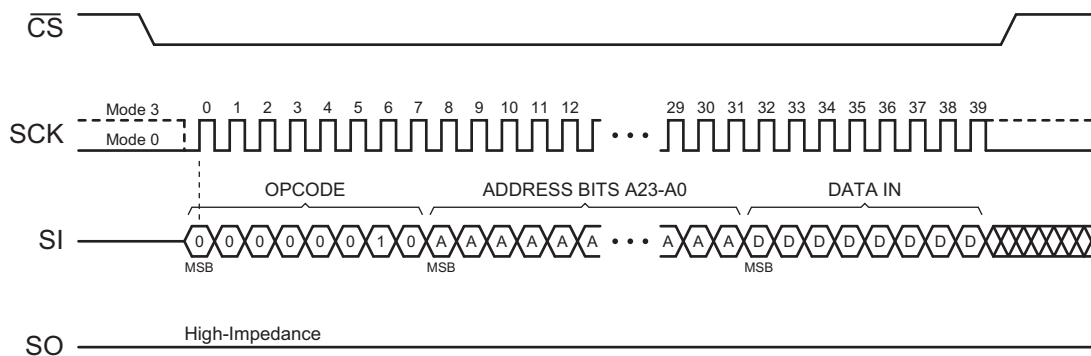

Figure 18. Byte Program

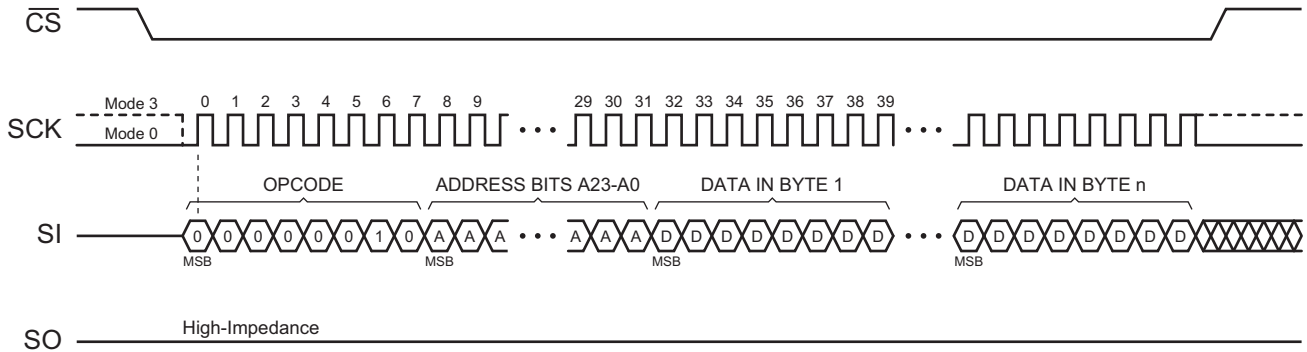

Figure 19. Page Program Timing

8.2 Quad Page Program (32h)

This command is for programming the memory using pins: IO_0 , IO_1 , IO_2 , and IO_3 . To use this command, the Quad enable (bit 9 in Status Register) must be set ($QE=1$). A Write Enable command must previously have been executed to set the Write Enable Latch bit before sending the Page Program command. The Quad Page Program command is entered by driving \overline{CS} low, followed by the command code (32H), three address bytes, and at least one data byte on I/O pins.

Figure 20 shows the command sequence. If more than 256 bytes are sent to the device, previously latched data are discarded, and the last 256 data bytes are guaranteed to be programmed correctly within the same page. If fewer than 256 data bytes are sent to device, they are correctly programmed at the requested addresses without affecting other bytes of the same page. \overline{CS} must be driven high after the eighth bit of the last data byte has been latched in; otherwise, the Quad Page Program command is not executed.

As soon as \overline{CS} is driven high, the self-timed Quad Page Program cycle (whose duration is t_{pp}) is initiated. While the Quad Page Program cycle is in progress, the Status Register can be read to check the value of the RDY/BSY bit. The RDY/BSY bit is 1 during the self-timed Quad Page Program cycle; it is 0 when done. At some unspecified time before the cycle is completed, the Write Enable Latch bit is reset. A Quad Page Program command applied to a page which is protected by the Block Protect (BP4, BP3, BP2, BP1, BP0) bits (see Table 4 and Table 5) is not executed.

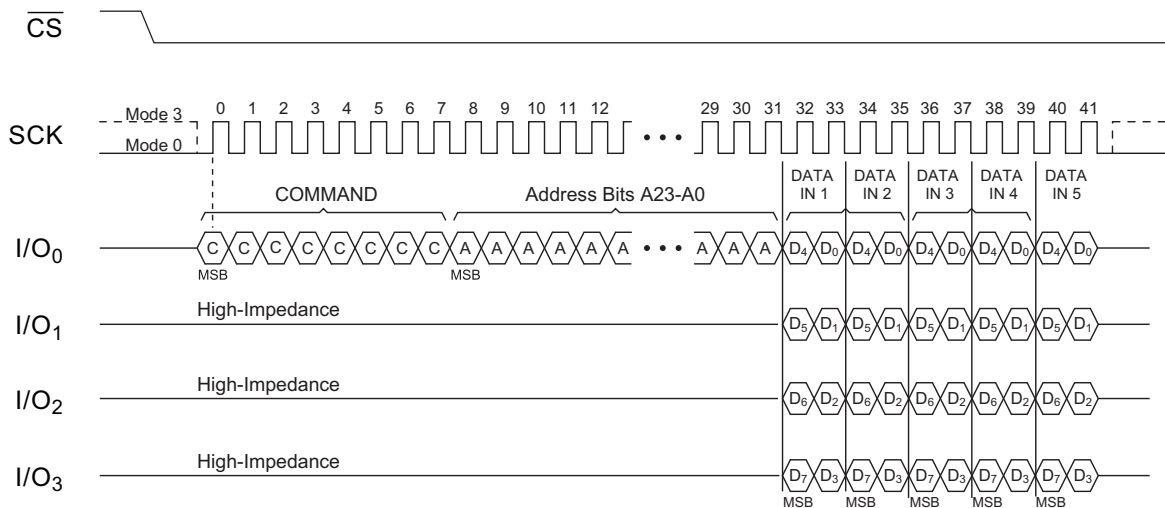

Figure 20. Quad Page Program (32h) Timing

8.3 Block Erase (20h, 52h, or D8h)

A block of 4-, 32-, or 64-kbyte can be erased (all bits set to the logical 1 state) in a single operation by using one of three different opcodes for the Block Erase command. An opcode of 20h is used for a 4-kbyte erase, an opcode of 52h is used for a 32-kbyte erase, and D8h is used for a 64-kbyte erase. Before a Block Erase command can be started, the Write Enable command must have been previously issued to the device to set the WEL bit of the Status Register to a logical 1 state.

To perform a Block Erase, the \overline{CS} pin must first be asserted and the appropriate opcode (20h, 52h, or D8h) must be clocked into the device. After the opcode has been clocked in, the three address bytes specifying an address within the 4- or 32- or 64-kbyte block to be erased must be clocked in. Any additional data clocked into the device is ignored. When the \overline{CS} pin is deasserted, the device erases the appropriate block. The erasing of the block is internally self-timed and takes place in a time of t_{BLKE} .

Since the Block Erase command erases a region of bytes, the lower order address bits do not need to be decoded by the device. Therefore, for a 4-kbyte erase, address bits A11-A0 are ignored by the device, and their values can be either a logical 1 or 0. For a 32-kbyte erase, address bits A14-A0 are ignored by the device. For a 64-kbyte erase, address bits A15-A0 are ignored by the device. Despite the lower-order address bits not being decoded by the device, the complete three address bytes must still be clocked into the device before the \overline{CS} pin is deasserted, and the \overline{CS} pin must be deasserted on a byte boundary (multiples of eight bits); otherwise, the device aborts the operation, and no erase operation is performed.

If the memory is in the protected state, the Block Erase command is not executed, and the device returns to the idle state once the \overline{CS} pin has been deasserted.

The WEL bit in the Status Register is reset to the logical 0 state if: the erase cycle aborts due to an incomplete address being sent, the \overline{CS} pin is deasserted on uneven byte boundaries, or because a memory location within the region to be erased is protected.

While the device is executing a successful erase cycle, the Status Register can be read and indicates that the device is busy. For faster throughput, poll the Status Register to determine if the device has finished erasing. At some point, before the erase cycle completes, the WEL bit in the Status Register is reset to the logical 0 state.

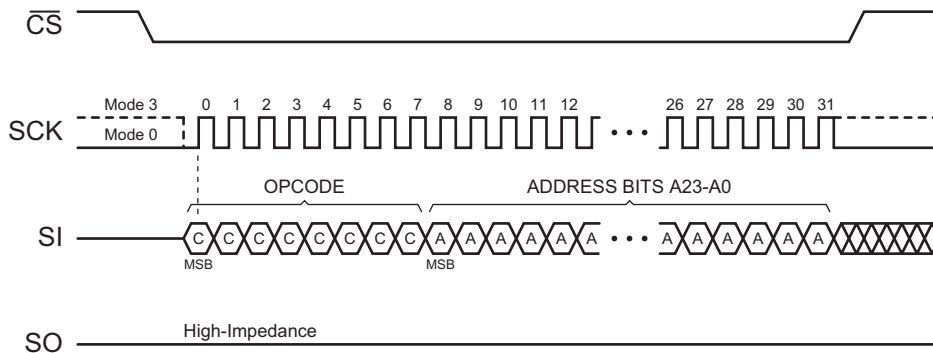

Figure 21. Block Erase

8.4 Chip Erase (60h or C7h)

The entire memory array can be erased in a single operation by using the Chip Erase command. Before a Chip Erase command can be started, the Write Enable command must have been previously issued to the device; this sets the WEL bit of the Status Register to a logical 1 state.

Two opcodes (60h and C7h) can be used for the Chip Erase command. There is no difference in device functionality when using the two opcodes; thus, they can be used interchangeably. To perform a Chip Erase, one of the two opcodes must be clocked into the device. Since the entire memory array is to be erased, no address bytes need to be clocked into the device, and any data clocked in after the opcode is ignored. When the \overline{CS} pin is deasserted, the device erases the entire memory array. The erasing of the device is internally self-timed and takes place in a time of t_{CHPE} .

The complete opcode must be clocked into the device before the \overline{CS} pin is deasserted, and the \overline{CS} pin must be deasserted on a byte boundary (multiples of eight bits); otherwise, no erase is performed. Also, if the memory array is in the protected state, the Chip Erase command is not executed, and the device returns to the idle state once the \overline{CS} pin has been deasserted. The WEL bit in the Status Register is reset to the logical 0 state if the \overline{CS} pin is deasserted on uneven byte boundaries, or if the memory is in the protected state.

While the device is executing a successful erase cycle, the Status Register can be read and indicates that the device is busy. For faster throughput, it is recommended that the Status Register be polled to determine if the device has finished erasing. At some point before the erase cycle completes, the WEL bit in the Status Register is reset to the logical 0 state.

8.5 Program/Erase Suspend (75h)

The Program/Erase Suspend command allows an in-progress program or erase operation to be suspended so that other device operations can be performed. For example, by suspending an erase operation to a particular block, the system can perform functions such as a program or read to a different block.

Chip Erase cannot be suspended. The Program/Erase Suspend command is ignored if it is issued during a Chip Erase. A program operation can be performed while an erase operation is suspended, but the program operation cannot be suspended while an erase operation is currently suspended.

Other device operations, such as a Read Status Register, can also be performed while a program or erase operation is suspended.

Since the need to suspend a program or erase operation is immediate, the Write Enable command does not need to be issued prior to the Program/Erase Suspend command being issued. Thus, the Program/Erase Suspend command operates independently of the state of the WEL bit in the Status Register.

To perform a Program/Erase Suspend, the \overline{CS} pin must first be asserted, and the 75h opcode must be clocked into the device. No address bytes need to be clocked into the device, and any data clocked in after the opcode is ignored. When the \overline{CS} pin is deasserted, the program or erase operation currently in progress is suspended. The Suspend (E_SUS or P_SUS) bits in the Write Status Register are set to the logical 1 state to indicate that the program or erase operation has been suspended. Also, the $\overline{RDY/BSY}$ bit in the Status Register indicates that the device is ready for another operation. The complete opcode must be clocked into the device before the \overline{CS} pin is deasserted, and the \overline{CS} pin must be deasserted on a byte boundary (multiples of eight bits); otherwise, no suspend operation is performed.

A program operation is not allowed to a block that has been erase suspended. If a program operation is attempted to an erase suspended block, then the program operation aborts, and the WEL bit in the Status Register is reset to a logical 0 state. Likewise, an erase operation is not allowed to a block that included the page that has been program suspended. If attempted, the erase operation aborts, and the WEL bit in the Status Register is reset to a logical 0 state.

If an attempt is made to perform an operation that is not allowed during a program or erase suspend, such as a Write Status Register operation, the device ignores the opcode, and no operation is performed. The state of the WEL bit in the Status Register is not affected.

Note: Repeated suspend/resume sequences might significantly impact progress of the erase or program operation. To ensure timely completion of the erase or program operation, limit the number of suspend/resume sequences during the same erase or program operation; alternatively, provide sufficient time (up to 60 ms) after a resume operation to allow the erase or program operation to complete.

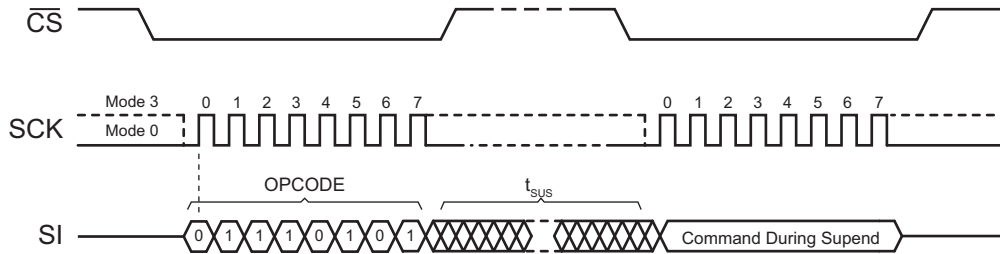

Figure 22. Erase/Program Suspend Timing

Note: See application note AN500 for operational guidance on implementing suspend and resume operations.

8.6 Program/Erase Resume (7Ah)

The Program/Erase Resume command allows a suspended program or erase operation to be resumed and continue programming a Flash page or erasing a Flash memory block where it left off. The Program/Erase Resume command is accepted by the device only if the E_SUS or P_SUS bits in the Write Status Register is 1, and the RDY/BSY bit is 0. If the E_SUS or P_SUS bits is 0, or the RDY/BSY bit is 1, the Program/Erase Resume command is ignored by the device. As with the Program/Erase Suspend command, the Write Enable command does not need to be issued before to the Program/Erase Resume command is issued. Thus, the Program/Erase Resume command operates independently of the state of the WEL bit in the Status Register.

To perform Program/Erase Resume, the CS pin must first be asserted, and opcode 7Ah must be clocked into the device.

No address bytes need to be clocked into the device, and any data clocked in after the opcode is ignored. When the CS pin is deasserted, the program or erase operation currently suspended resumes. The E_SUS or P_SUS bit in the Status Register is reset back to the logical 0 state to indicate the program or erase operation is no longer suspended. Also, the RDY/BSY bit in the Status Register indicates that the device is busy performing a program or erase operation. The complete opcode must be clocked into the device before the CS pin is deasserted, and the CS pin must be deasserted on a byte boundary (multiples of eight bits); otherwise, no resume operation is performed.

During a simultaneous Erase Suspend/Program Suspend condition, issuing the Program/Erase Resume command results in the program operation resuming first. After the program operation has been completed, the Program/Erase Resume command must be issued again for the erase operation to be resumed.

While the device is busy resuming a program or erase operation, any attempts at issuing the Program/Erase Suspend command are ignored. Thus, if a resumed program or erase operation needs to be subsequently suspended again, the system must either wait before issuing the Program/Erase Suspend command, or it must check the status of the RDY/BSY bit or the E_SUS or P_SUS bit in the Status Register to determine if the previously suspended program or erase operation has resumed.

9. Protection Commands and Features

9.1 Write Enable (06h)

The Write Enable command sets the Write Enable Latch (WEL) bit in the Status Register to a logical 1 state. The WEL bit must be set before a Byte/Page Program, Erase, Program Security Register Pages, Erase Security Register Pages or Write Status Register command can be executed. This makes the issuance of these commands a two step process, thus reducing the chances of a command being accidentally or erroneously executed. If the WEL bit in the Status Register is not set prior to the issuance of one of these commands, the command is not executed.

To issue the Write Enable command, the \overline{CS} pin must first be asserted, and the opcode of 06h must be clocked into the device. No address bytes need to be clocked into the device, and any data clocked in after the opcode is ignored. When the \overline{CS} pin is deasserted, the WEL bit in the Status Register is set to a logical 1. The complete opcode must be clocked into the device before the \overline{CS} pin is deasserted, and the \overline{CS} pin must be deasserted on an byte boundary (multiples of eight bits); otherwise, the device aborts the operation, and the WEL bit state does not change.

9.2 Write Disable (04h)

The Write Disable command resets the Write Enable Latch (WEL) bit in the Status Register to the logical 0 state. With the WEL bit reset, all Byte/Page Program, Erase, Program Security Register Page, and Write Status Register commands are not executed. Other conditions can also cause the WEL bit to be reset; for more details, see the WEL bit section of the Status Register description ([Section 11](#)).

To issue the Write Disable command, the \overline{CS} pin must be asserted first, and the opcode of 04h must be clocked into the device. No address bytes need to be clocked into the device, and any data clocked in after the opcode is ignored. When the \overline{CS} pin is deasserted, the WEL bit in the Status Register is reset to a logical 0. The complete opcode must be clocked into the device before the \overline{CS} pin is deasserted, and the \overline{CS} pin must be deasserted on an byte boundary (multiples of eight bits); otherwise, the device aborts the operation, and the WEL bit state does not change.

9.3 Non-Volatile Protection

The device can be software-protected against erroneous or malicious program or erase operations by using the Non-Volatile Protection feature. This feature can be enabled or disabled by using the Write Status Register command to change the value of the Protection (CMP, BP4, BP3, BP2, BP1, BP0) bits in the Status Register.

Table 4 outlines the states of the Protection bits and the associated protection area.

Table 4. Memory Array with CMP = 0

Protection Bits					Memory Content	
BP4	BP3	BP2	BP1	BP0	Address Range	Portion
X	X	0	0	0	None	None
0	0	0	0	1	1F0000h - 1FFFFFFh	Upper 1/32
0	0	0	1	0	1E0000h - 1FFFFFFh	Upper 1/16
0	0	0	1	1	1C0000h - 1FFFFFFh	Upper 1/8
0	0	1	0	0	180000h - 1FFFFFFh	Upper 1/4
0	0	1	0	1	100000h - 10FFFFFFh	Upper 1/2
0	1	0	0	1	000000h - 00FFFFFFh	Lower 1/32
0	1	0	1	0	000000h - 01FFFFFFh	Lower 1/16
0	1	0	1	1	000000h - 03FFFFFFh	Lower 1/8
0	1	1	0	0	000000h - 07FFFFFFh	Lower 1/4
0	1	1	0	1	000000h - 0FFFFFFh	Lower 1/2
X	X	1	1	X	000000h - 1FFFFFFh	ALL
1	0	0	0	1	1FF000h - 1FFFFFFh	Upper 1/512
1	0	0	1	0	1FE000h - 1FFFFFFh	Upper 1/256
1	0	0	1	1	1FC000h - 1FFFFFFh	Upper 1/128
1	0	1	0	X	1F8000h - 1FFFFFFh	Upper 1/64
1	1	0	0	1	000000h - 000FFFh	Lower 1/512
1	1	0	1	0	000000h - 001FFFh	Lower 1/256
1	1	0	1	1	000000h - 003FFFh	Lower 1/128
1	1	1	0	X	000000h - 007FFFh	Lower 1/64

Table 5. Memory Array Protection with CMP = 1

Protection Bits					Memory Content	
BP4	BP3	BP2	BP1	BP0	Address Range	Portion
X	X	0	0	0	000000h - 1FFFFFFh	All
0	0	0	0	1	000000h - 1EFFFFh	Lower 31/32
0	0	0	1	0	000000h - 1DFFFFh	Lower 15/16
0	0	0	1	1	000000h - 1BFFFFh	Lower 7/8
0	0	1	0	0	000000h - 17FFFFh	Lower 3/4
0	0	1	0	1	000000h - 0FFFFFFh	Lower 1/2
0	1	0	0	1	010000h - 1FFFFFFh	Upper 31/32
0	1	0	1	0	020000h - 1FFFFFFh	Upper 15/16
0	1	0	1	1	040000h - 1FFFFFFh	Upper 7/8
0	1	1	0	0	080000h - 1FFFFFFh	Upper 3/4
0	1	1	0	1	100000h - 1FFFFFFh	Upper 1/2
X	X	1	1	X	NONE	NONE
1	0	0	0	1	000000h - 1FEFFFFh	Lower 511/512
1	0	0	1	0	000000h - 1FDFFFFh	Lower 255/256
1	0	0	1	1	000000h - 1FBFFFFh	Lower 127/128
1	0	1	0	X	000000h - 1F7FFFFh	Lower 63/64
1	1	0	0	1	001000h - 1FFFFFFh	Upper 511/512
1	1	0	1	0	002000h - 1FFFFFFh	Upper 255/256
1	1	0	1	1	004000h - 1FFFFFFh	Upper 127/128
1	1	1	0	X	008000h - 1FFFFFFh	Upper 63/64

As a safeguard against accidental or erroneous protecting or unprotecting of the memory array, the Protection can be locked from updates by using the $\overline{\text{WP}}$ pin (see [Section 9.4](#), for more details).

9.4 Protected States and the Write Protect Pin

The $\overline{\text{WP}}$ pin is not linked to the memory array itself and has no direct effect on the protection status of the memory array. Instead, it controls the hardware locking mechanism of the device.

If the $\overline{\text{WP}}$ pin is permanently connected to GND, then the protection bits cannot be changed.

9.5 Enable Reset (66h) and Reset Device (99h)

Because of the small package and the limitation on the number of pins, the AT25SF161B provides a software Reset command instead of a dedicated RESET pin. Once the software Reset command is accepted, any on-going internal operations are terminated, and the device returns to its default power-on state and loses all the current volatile settings, including the Volatile Status Register bits, Write Enable Latch (WEL) status, Program/Erase Suspend status, Continuous Read Mode bit setting (M7-M0), and Wrap Bit setting (W6-W4).

To avoid accidental reset, the Enable Reset and Reset Device commands must be issued in sequence. Any other commands other than Reset (99h) after the Enable Reset (66h) command disables the Reset Enable state. A new sequence of Enable Reset and Reset Device is needed to reset the device. Once the Reset command is accepted by the device, the device takes approximately 30 μs to reset. During this period, no command is accepted.

The Enable Reset and Reset Device command sequence are shown in [Figure 23](#).

Data corruption can happen if there is an on-going or suspended internal Erase or Program operation when the Reset command sequence is accepted by the device. Check the BUSY bit and the E_SUS and P_SUS bits in the Status Register before issuing the Reset command sequence.

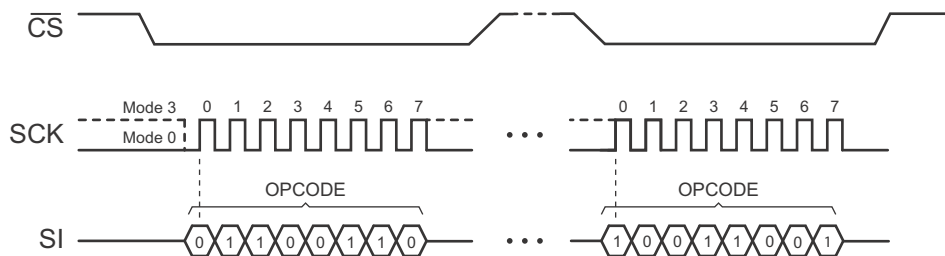

Figure 23. Enable Reset (66h) and Reset Device (99h) Command Timing (SPI Mode)

10. Security Register Commands

The device contains three extra Security Register pages that can be used for unique device serialization, system-level Electronic Serial Number (ESN) storage, locked key storage, etc. The Security Registers are independent of the main Flash memory.

Each page of the Security Register can be erased and programmed independently. Each page can also be independently locked to prevent further changes.

10.1 Read Unique ID Number (4Bh)

The Read Unique ID Number command accesses a factory-set, read-only 64-bit number that is unique to each AT25SF161B device. The ID number can be used in conjunction with user software methods to help prevent copying or cloning of a system. The Read Unique ID command is initiated by driving the \overline{CS} pin low and shifting the command code 4Bh, followed by four dummy byte clock cycles. After this, the 64-bit ID is shifted out on the falling edge of SCK, as shown in Figure 24.

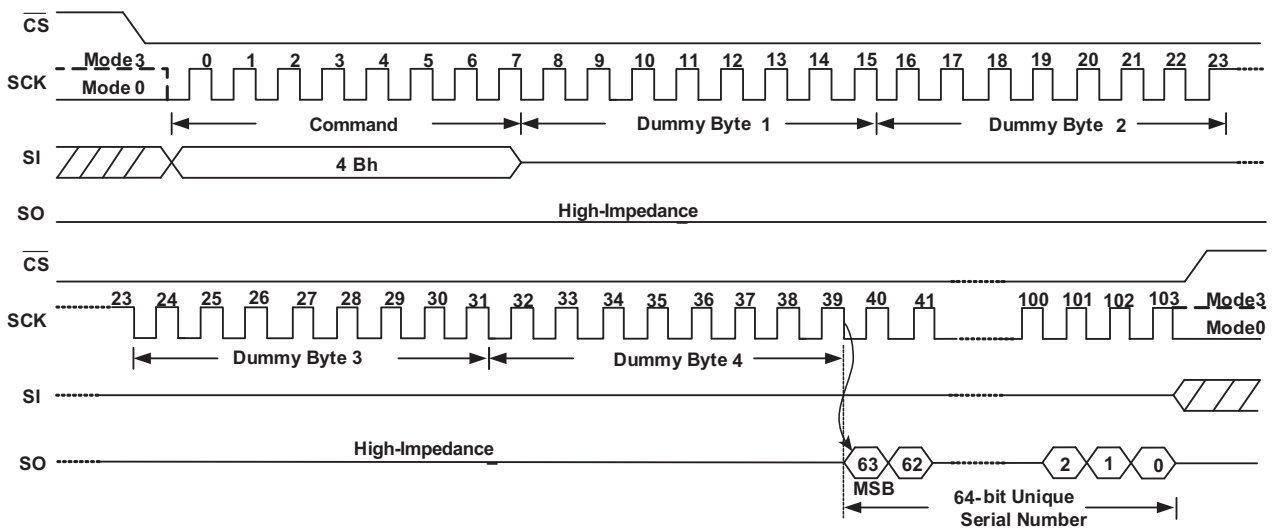

Figure 24. Read Unique ID Timing (SPI Mode)

10.2 Erase Security Registers (44h)

Before an erase Security Register Page command can be started, the Write Enable command must have been previously issued to the device to set the WEL bit of the Status Register to a logical 1 state.

To perform an Erase Security Register Page command, the \overline{CS} pin must be asserted first, and the opcode 44h must be clocked into the device. After the opcode has been clocked in, the three address bytes specifying the Security Register Page to be erased must be clocked in. When the \overline{CS} pin is deasserted, the device erases the appropriate page. The erasing of the page is internally self-timed and takes place in a time of t_{pp} .

Since the Erase Security Register Page command erases a region of bytes, the lower-order address bits do not need to be decoded by the device. Thus, address bits A7-A0 are ignored by the device. Despite the lower-order address bits not being decoded by the device, the complete three address bytes must be clocked into the device before the \overline{CS} pin is deasserted, and the \overline{CS} pin must be deasserted right after the last address bit (A0); otherwise, the device aborts the operation, and no erase operation is performed.

While the device is executing a successful erase cycle, the Status Register can be read and indicates that the device is busy. For faster throughput, it is recommended that the Status Register be polled (rather than waiting the t_{pp} time to determine if the device has finished erasing). At some point before the erase cycle completes, the RDY/BSY bit in the Status Register is reset to the logical 0 state.

The WEL bit in the Status Register is reset to the logical 0 state if: the erase cycle aborts due to an incomplete address being sent, the \overline{CS} pin being deasserted on uneven byte boundaries, or because a memory location within the region to be erased is protected.

The Security Registers Lock Bits (LB3 - LB1) in the Status Register can be used to OTP protect the security registers. Once a Lock Bit is set to 1, the corresponding Security Register is permanently locked. The Erase Security Register Page command is ignored for Security Registers with their Lock Bit set.

Table 6. Security Register Addresses for Erase Security Register Page Command

Address	A23 - A16	A15 - A12	A11 - A8	A7 - A0
Security Register 1	00h	1h	0h	Don't Care
Security Register 2	00h	2h	0h	Don't Care
Security Register 3	00h	3h	0h	Don't Care

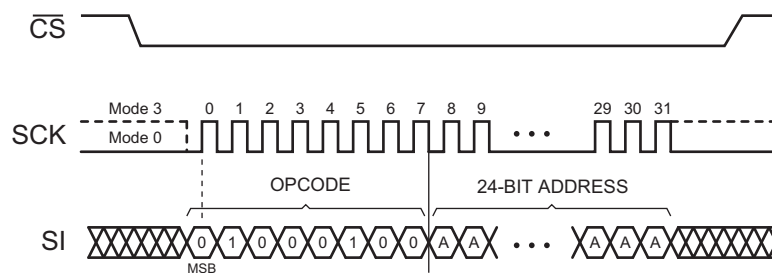

Figure 25. Erase Security Register Page

10.3 Program Security Registers (42h)

The Program Security Registers command uses the internal 256-byte buffer for processing. Thus, the contents of the buffer are altered from their previous state when this command is issued.

The Security Registers can be programmed in a similar fashion to the Program Array operation up to the maximum clock frequency specified by f_{CLK} . Before a Program Security Registers command can be started, the Write Enable command must have been previously issued to the device (see Section 9.1) to set the Write Enable Latch (WEL) bit of the Status Register to a logical 1 state. To program the Security Registers, the \overline{CS} pin must first be asserted, and the opcode of 42h must be clocked into the device. After the opcode has been clocked in, the three address bytes must be clocked in to specify the starting address location of the first byte to program within the Security Register.

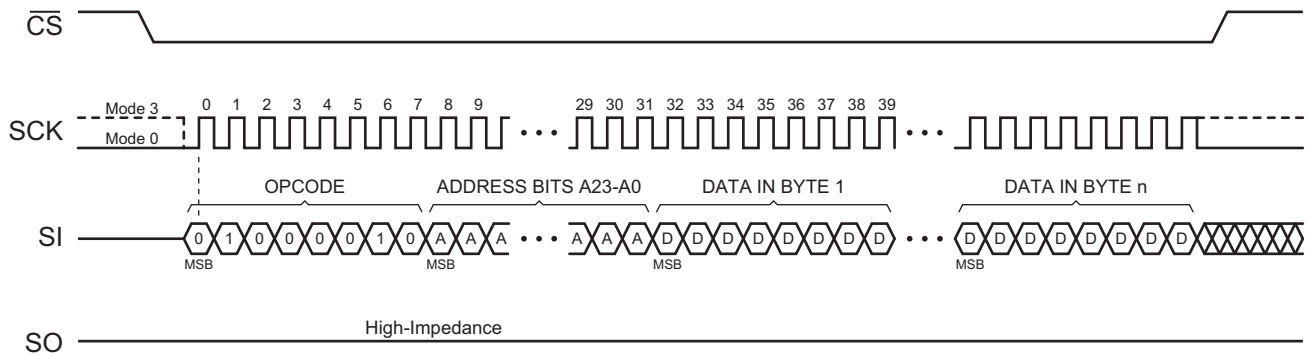

Figure 26. Program Security Registers

Table 7. Security Register Addresses for Program Security Registers Command

Address	A23 - A16	A15 - A12	A11 - A8	A7 - A0
Security Register 1	00h	1h	0h	Byte Address
Security Register 2	00h	2h	0h	Byte Address
Security Register 3	00h	3h	0h	Byte Address

10.4 Read Security Registers (48h)

The Security Register can be sequentially read in a similar fashion to the Read Array operation up to the maximum clock frequency specified by f_{CLK} . To read the Security Register, the \overline{CS} pin must first be asserted and the opcode of 48h must be clocked into the device. After the opcode has been clocked in, the three address bytes must be clocked in to specify the starting address location of the first byte to read within the Security Register. Following the three address bytes, one dummy byte must be clocked into the device before data can be output.

After the three address bytes and the dummy byte have been clocked in, additional clock cycles result in the Security Register data being output on the SO pin. When the last byte (0003FFh) of the Security Register has been read, the device continues reading back at the beginning of the register (000000h). No delays are incurred when wrapping around from the end of the register to the beginning of the register.

Deasserting the \overline{CS} pin terminates the read operation and puts the SO pin into a high-impedance state. The \overline{CS} pin can be deasserted at any time and does not require that a full byte of data be read.

Table 8. Security Register Addresses for Read Security Registers Command

Address	A23 - A16	A15 - A12	A11 - A8	A7 - A0
Security Register 1	00h	1h	0h	Byte Address
Security Register 2	00h	2h	0h	Byte Address
Security Register 3	00h	3h	0h	Byte Address

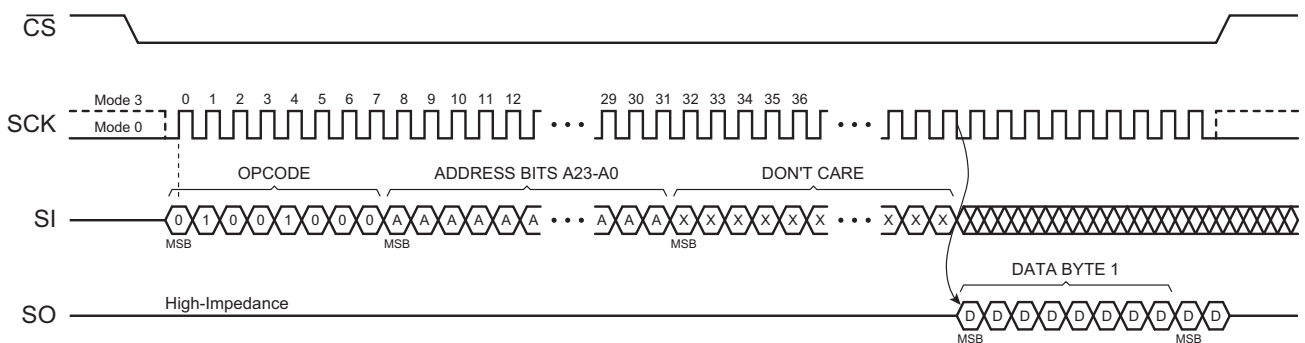

Figure 27. Read Security Registers

11. Status Register Commands

11.1 Read Status Register (05h, 35h, and 15h)

The Status Register can be read to determine the device's ready/busy status, as well as the status of many other functions, such as Block Protection. The Status Register can be read at any time, including during an internally self-timed program or erase operation.

To read Status Register 1, the \overline{CS} pin must first be asserted and the opcode of 05h must be clocked into the device. After the opcode has been clocked in, the device begins outputting Status Register 1 data on the SO pin during every subsequent clock cycle. After the last bit (0) of Status Register 1 has been clocked out, the sequence repeats itself, starting again with bit 7, as long as the \overline{CS} pin remains asserted and the clock pin is being pulsed. The data in the Status Register is constantly being updated, so each repeating sequence outputs new data. Deasserting the \overline{CS} pin terminates the Read Status Register operation and puts the SO pin into a high-impedance state. The \overline{CS} pin can be deasserted at any time and does not require that a full byte of data be read.

Table 9. Status Register 1 Bit Assignments

Bit ¹	Mnemonic	Name	Type ²	Description	
7	SRP0	Status Register Protection bit 0	R/W		See Table 12 on Status Register Protection.
6	BP4	Block Protection	R/W		See Table 4 and Table 5 on Non-Volatile Protection.
5	BP3	Top or Bottom Protection	R/W		
4	BP2	Block Protection bit 2	R/W		
3	BP1	Block Protection bit 1	R/W		
2	BP0	Block Protection bit 0	R/W		
1	WEL	Write Enable Latch Status	R	0	Device is not Write Enabled (default).
				1	Device is Write Enabled.
0	$\overline{RDY/BSY}$	Ready/Busy Status	R	0	Device is ready.
				1	Device is busy with an internal operation.

1. Only bits designated as R/W can be modified when using the Write Status Register command. Bits designated as R cannot be modified.
2. R/W = Readable and writable; R = Readable only.

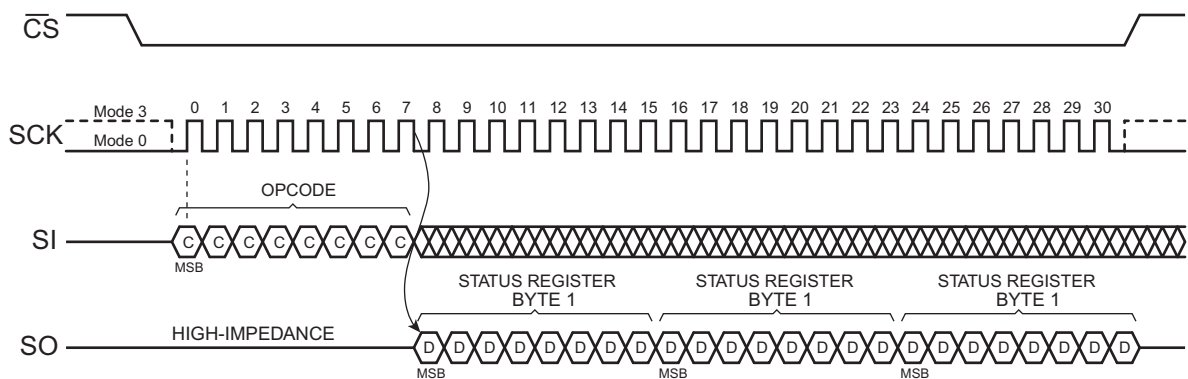

Figure 28. Read Status Register 1

To read Status Register 2, the \overline{CS} pin must first be asserted, and the opcode of 35h must be clocked into the device. After the opcode has been clocked in, the device begins outputting Status Register 2 data on the SO pin during every subsequent clock cycle. After the last bit (0) of Status Register 2 has been clocked out, the sequence repeats, itself starting again with bit 7, as long as the \overline{CS} pin remains asserted and the clock pin is being pulsed. The data in the Status Register is constantly being updated, so each repeating sequence outputs new data.

Deasserting the \overline{CS} pin terminates the Read Status Register operation and puts the SO pin into a high-impedance state. The \overline{CS} pin can be deasserted at any time and does not require that a full byte of data be read.

Table 10. Status Register 2 Bit Assignments

Bit ⁽¹⁾	Name		Type	Description	
7	E_SUS	Erase Suspend Status	R	0	Erase operation is not suspended (default).
				1	Erase operation is suspended.
6	CMP	Complement Block Protection	R/W	0	See Table 4 and Table 5 on Block Protection.
5	LB3	Lock Security Register 3	R/W	0	Security Register page-3 is not locked (default).
				1	Security Register page-3 cannot be erased/programmed.
4	LB2	Lock Security Register 2	R/W	0	Security Register page-2 is not locked (default).
				1	Security Register page-2 cannot be erased/programmed.
3	LB1	Lock Security Register 1	R/W	0	Security Register page-1 is not locked (default).
				1	Security Register page-1 cannot be erased/programmed.
2	P_SUS	Program Suspend Status	R	0	Program operation is not suspended (default).
				1	Program operation is suspended.
1	QE	Quad Enable	R/W	0	\overline{HOLD} and \overline{WP} function normally (default).
				1	\overline{HOLD} and \overline{WP} are I/O pins.
0	SRP1	Status Register Protect bit 1	R/W		See Table 12 on Status Register Protection.

1. Only bits designated as R/W can be modified when using the Write Status Register command. Bits designated as R cannot be modified.
2. R/W = Readable and writable. R = Readable only.

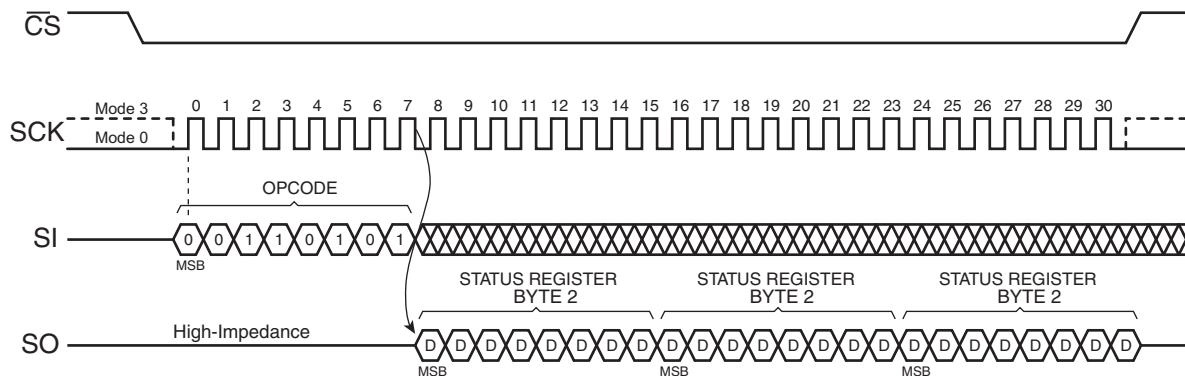

Figure 29. Read Status Register 2

To read Status Register 3, the \overline{CS} pin must first be asserted, and the opcode of 15h must be clocked into the device. After the opcode has been clocked in, the device begins outputting Status Register 3 data on the SO pin during every subsequent clock cycle. After the last bit (0) of Status Register 3 has been clocked out, the sequence repeats itself starting again with bit 7 as long as the \overline{CS} pin remains asserted and the clock pin is being pulsed. The data in the Status Register is constantly being updated, so each repeating sequence outputs new data. Deasserting the \overline{CS} pin terminates the Read Status Register operation and puts the SO pin into a high-impedance state. The \overline{CS} pin can be deasserted at any time and does not require that a full byte of data be read.

Table 11 shows the bit assignments for Status Register 3.

Table 11. Status Register 3 Bit Assignments

Bit ⁽¹⁾	Mnemonic	Name	Type ⁽²⁾	Description	
7	Res	Reserved	R/W	0	Reserved bit.
6:5	DRV[1:0]	Drive Strength	R/W	11	Drive level. The DRV1 and DRV0 bits are used to determine the output driver strength during read operations. A setting of 2'b11 allows the drive strength to be set by hardware based on the VCC level. Four drive settings are supported. This field is encoded as follows: 11: Auto (7 pF based on VCC level) 10: 50% (15 pF) 01: 75% (22 pF) 00: 100% (30 pF)
4:0	Res	Reserved	R/W	0	Reserved bit.

1. Only bits designated as R/W can be modified when using the Write Status Register command. Bits designated as R cannot be modified.
2. R/W = Readable and writable. R = Readable only.

11.1.1 SRP1, SRP0 Bits

The SRP1 and SRP0 bits determine if the Status Register can be modified. The state of the \overline{WP} pin, along with the values of the SRP1 and SRP0, determine if the device is software-protected, hardware-protected, or permanently protected, as shown in Table 12.

Table 12. Status Register Protection Table

SRP1	SRP0	WP	Status Register	Description
0	0	X	Software Protected	The Status Register can be written to after a Write Enable command, WEL = 1.(Factory Default)
0	1	0	Hardware Protected	$\overline{WP} = 0$, the Status Register is locked and cannot be written.
0	1	1	Hardware Unprotected	$\overline{WP} = 1$, the Status Register is unlocked and can be written to after a Write Enable command, WEL = 1.
1	0	X	Power Supply Lock-Down ¹	Status Register is protected and cannot be written to again until the next Power-Down, Power-Up cycle.

1. When SRP1, SRP0 = (1, 0), a Power-Down, Power-Up cycle changes SRP1, SRP0 to the (0, 0) state.

11.1.2 CMP, BP4, BP3, BP2, BP1, BP0 Bits

The CMP, BP4, BP3, BP2, BP1, and BP0 bits control which portions of the array are protected from erase and program operations (see Table 4 and Table 5).

The CMP bit complements the effect of the other bits.

The BP4 bit selects between large and small block size protection.

The BP3 bit selects between top of the array or bottom of the array protection.

The BP2, BP1, and BP0 bits determine how much of the array is protected.

11.1.3 WEL Bit

The WEL bit indicates the current status of the internal Write Enable Latch. When the WEL bit is in the logical 0 state, the device does not accept any Byte/Page Program, erase, Program Security Register, Erase Security Register, or Write Status Register commands. The WEL bit defaults to the logical 0 state after a device power-up or reset operation. Also, the WEL bit is reset to the logical 0 state automatically under the following conditions:

- Write Disable operation completes successfully.
- Write Status Register operation completes successfully or aborts.
- Program Security Register operation completes successfully or aborts.

- Erase Security Register operation completes successfully or aborts.
- Byte/Page Program operation completes successfully or aborts.
- Block Erase operation completes successfully or aborts.
- Chip Erase operation completes successfully or aborts.

If the WEL bit is in the logical 1 state, it is not reset to a logical 0 if an operation aborts because of an incomplete or unrecognized opcode being clocked into the device before the $\overline{\text{CS}}$ pin is deasserted. For the WEL bit to be reset when an operation aborts prematurely, the entire opcode for a Byte/Page Program, erase, Program Security Register, Erase Security Register, or Write Status Register command must have been clocked into the device.

11.1.4 $\overline{\text{RDY/BSY}}$ Bit

The $\overline{\text{RDY/BSY}}$ bit determines whether or not an internal operation, such as a program or erase, is in progress. To poll the $\overline{\text{RDY/BSY}}$ bit to detect the completion of a program or erase cycle, new Status Register data must be continually clocked out of the device until the state of the $\overline{\text{RDY/BSY}}$ bit changes from a logical 1 to a logical 0.

11.1.5 LB3, LB2, LB1 Bits

The LB3, LB2, and LB1 bits are used to determine if any of the three Security Register pages are locked.

The LB3 bit is in the logical 1 state if Security Register page-2 is locked and cannot be erased or programmed.

The LB2 bit is in the logical 1 state if Security Register page-1 is locked and cannot be erased or programmed.

The LB1 bit is in the logical 1 state if Security Register page-0 is locked and cannot be erased or programmed.

11.1.6 E_SUS Bit

This bit is set and cleared by hardware and indicates the status of an erase operation. This bit is encoded as follows:

- 0: Erase operation is not suspended (default).
- 1: Erase operation is suspended.

Hardware clears this bit once the condition that caused the erase suspend operation has been removed.

Hardware typically sets this bit when a Program/Erase Suspend (75h) command is executed, and clears the bit when a Program/Erase Resume (7Ah) command is executed.

11.1.7 P_SUS Bit

This bit is set and cleared by hardware and indicates the status of a program operation. This bit is encoded as follows:

- 0: Program operation is not suspended (default).
- 1: Program operation is suspended.

Hardware clears this bit once the condition that caused the program suspend operation has been removed.

Hardware typically sets this bit when a Program/Erase Suspend (75h) command is executed, and clears the bit when a Program/Erase Resume (7Ah) command is executed.

11.1.8 QE Bit

The QE bit determines if the device is in the Quad Enabled mode. If the QE bit is in the logical 1 state, the $\overline{\text{HOLD}}$ and $\overline{\text{WP}}$ pins functions as input/output pins similar to the SI and SO. If the QE bit is in the logical 0 state, the $\overline{\text{HOLD}}$ pin functions as an input only and the $\overline{\text{WP}}$ pin functions as an input only.

11.2 Write Status Register (01h, 31h, 11h)

The Write Status Register command modifies the Block Protection, Security Register Lock-down, Quad Enable, and Status Register Protection. Before the Write Status Register command can be issued, the Write Enable command must have been previously issued to set the WEL bit in the Status Register to a logical 1.

The \overline{CS} pin must be driven high after the eighth bit of the data byte has been latched in. If not, the Write Status Register command is not executed. As soon as the \overline{CS} pin is driven high, the self-timed Write Status Register cycle is initiated.

While the Write Status Register cycle is in progress, the Status Register can be read to check the value of the RDY/BSY bit. The RDY/BSY bit is 1 during the self-timed Write Status Register cycle, and 0 when it is completed. When the cycle is completed, the Write Enable Latch is reset.

The Write Status Register command allows the user to change the values of the Block Protect (BP4, BP3, BP2, BP1, BP0) bits, to define the size of the area that is to be treated as read-only. The Write Status Register command also allows the user to set or reset the Status Register Protect (SRP1 and SRP0) bits in accordance with the Write Protect (\overline{WP}) pin.

The Status Register Protect (SRP1 and SRP0) bits and \overline{WP} pin allow the device to be put in the hardware protected mode. The Write Status Register command is not executed once the hardware protected mode is entered.

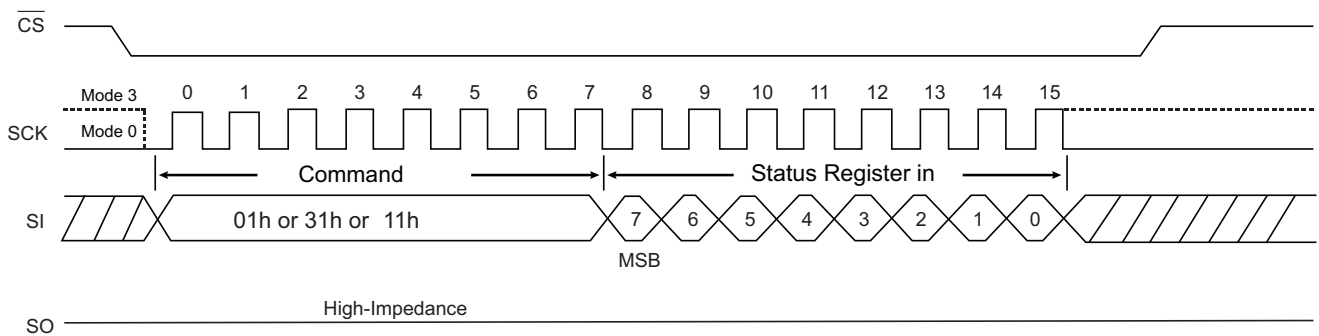

Figure 30. Write Status Register

Table 13. Write Status Register 1

Bit 7	Bit 6	Bit 5	Bit 4	Bit 3	Bit 2	Bit 1	Bit 0
SRP0	BP4	BP3	BP2	BP1	BP0	WEL	$\overline{RDY/BSY}$

Table 14. Write Status Register 2

Bit 7	Bit 6	Bit 5	Bit 4	Bit 3	Bit 2	Bit 1	Bit 0
E_SUS	CMP	LB3	LB2	LB1	P_SUS	QE	SRP1

Table 15. Write Status Register 3

Bit 7	Bit 6	Bit 5	Bit 4	Bit 3	Bit 2	Bit 1	Bit 0
Reserved	DRV1	DRV0	Reserved	Reserved	Reserved	Reserved	Reserved

11.3 Write Enable for Volatile Status Register (50h)

The non-volatile Status Register bits can be written to as volatile bits. During power-up reset, the non-volatile Status Register bits are copied to a volatile version of the Status Register that is used during device operation. This gives more flexibility to change the system configuration and memory protection schemes quickly without waiting for the typical non-volatile bit write cycles or affecting the endurance of the Status Register non-volatile bits.

To write the volatile version of the Status Register bits, the Write Enable for Volatile Status Register (50h) command must be issued prior to each Write Status Registers (01h) command. The Write Enable for Volatile Status Register command does not set the Write Enable Latch bit. It is valid only for the next Write Status Registers command, to change the volatile Status Register bit values.

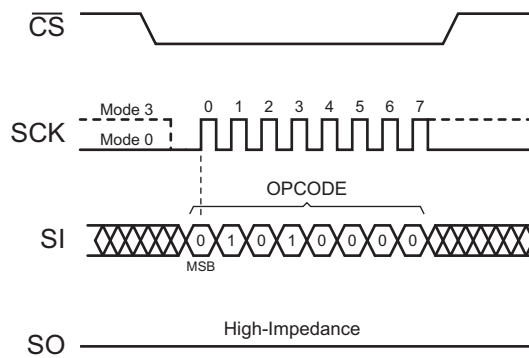

Figure 31. Write Enable for Volatile Status Register

12. Other Commands and Functions

The AT25SF161B supports three different commands to access device identification that indicates the manufacturer, device type, and memory density. The returned data bytes provide information, as shown in [Table 16](#).

Table 16. Manufacturer and Device ID Information

Command	Opcode	Dummy Bytes	Manufacturer ID (Byte #1)	Device ID (Byte #2)	Device ID (Byte #3)
Read Manufacturer and Device ID	9Fh	0	1Fh	86h	01h
Read ID (Legacy Command)	90h	3	1Fh		14h
Read ID (Dual I/O)	92h	3	1Fh		14h
Read ID (Quad I/O)	94h	3	1Fh		14h
Resume from Deep Power-Down and Read Device ID	ABh	3			14h

12.1 Read Manufacturer and Device ID (9Fh)

Identification information can be read from the device to enable systems to electronically query and identify the device.

Since not all Flash devices are capable of operating at very high clock frequencies, design applications to read the identification information from the devices at a reasonably low clock frequency to ensure all devices used in the application can be identified properly. Once the identification process is complete, the application can increase the clock frequency to accommodate specific Flash devices that are capable of operating at the higher clock frequencies.

To read the identification information, the \overline{CS} pin must first be asserted and the opcode of 9Fh must be clocked into the device. After the opcode has been clocked in, the device begins outputting the identification data on the SO pin during the subsequent clock cycles. The first byte output is the Manufacturer ID, followed by two bytes of Device ID information. Deasserting the \overline{CS} pin terminates the Manufacturer and Device ID read operation and puts the SO pin into a high-impedance state. The \overline{CS} pin can be deasserted at any time and does not require that a full byte of data be read.

Table 17. Manufacturer and Device ID Information

Byte Number	Data Type	Value
1	Manufacturer ID	1Fh
2	Device ID (Part 1)	86h
3	Device ID (Part 2)	01h

Table 18. Manufacturer and Device ID Details

Data Type	Bit 7	Bit 6	Bit 5	Bit 4	Bit 3	Bit 2	Bit 1	Bit 0	Hex Value	Details
Manufacturer ID	JEDEC Assigned Code								1Fh	JEDEC Code: 0001 1111 (1Fh for Renesas Electronics)
	0	0	0	1	1	1	1	1		
Device ID (Part 1)	Family Code			Density Code					86h	Family Code:100 (AT25SFxxx series) Density Code: 00110 (16-Mbit)
	1	0	0	0	0	1	1	0		
Device ID (Part 2)	Sub Code			Product Version Code					01h	Sub Code: 000 (Standard series) Product Version: 00001
	0	0	0	0	0	0	0	1		

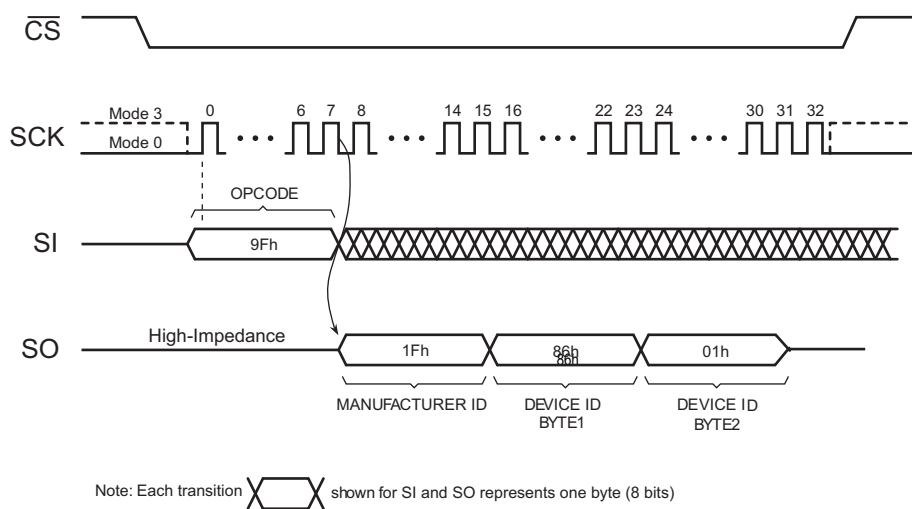

Figure 32. Read Manufacturer and Device ID

12.2 Read ID (Legacy Command) (90h)

Identification information can be read from the device to enable systems to electronically query and identify the device. The JEDEC standard method, described in [Section 12.1](#), is preferred; however, the legacy Read ID command is supported on the AT25SF161B to enable backwards compatibility to previous generation devices.

To read the identification information, the \overline{CS} pin must first be asserted, and the opcode 90h must be clocked into the device, followed by three dummy bytes. After the opcode has been clocked, in followed by three dummy bytes, the device begins outputting the identification data on the SO pin during the subsequent clock cycles. The first byte output is the Manufacturer ID of 1Fh, followed by a single byte of data representing a device code 14h. After the device code is output, the sequence of bytes repeats.

Deasserting the \overline{CS} pin terminates the Read ID operation and puts the SO pin into a high-impedance state. The \overline{CS} pin can be deasserted at any time and does not require that a full byte of data read.

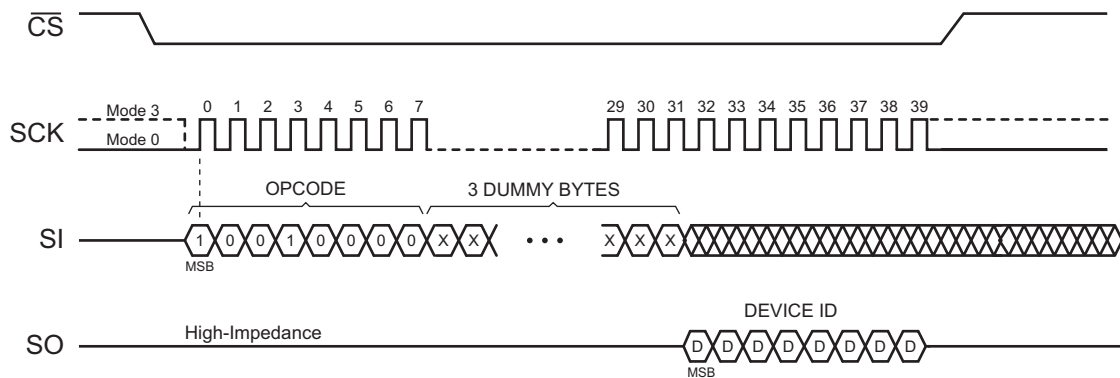

Figure 33. Read ID (Legacy Command)

12.3 Dual I/O Read Manufacture ID/ Device ID (92h)

The Dual I/O Read Manufacturer/Device ID command is an alternative to the Release from Power-Down/Device ID command that provides both the JEDEC-assigned Manufacturer ID and the specific Device ID by Dual I/O.

The command is initiated by driving the \overline{CS} pin low and shifting the command code 92h, followed by a 24-bit address (A23 - A0) of 000000h. If the 24-bit address is initially set to 000001h, the Device ID is read first.

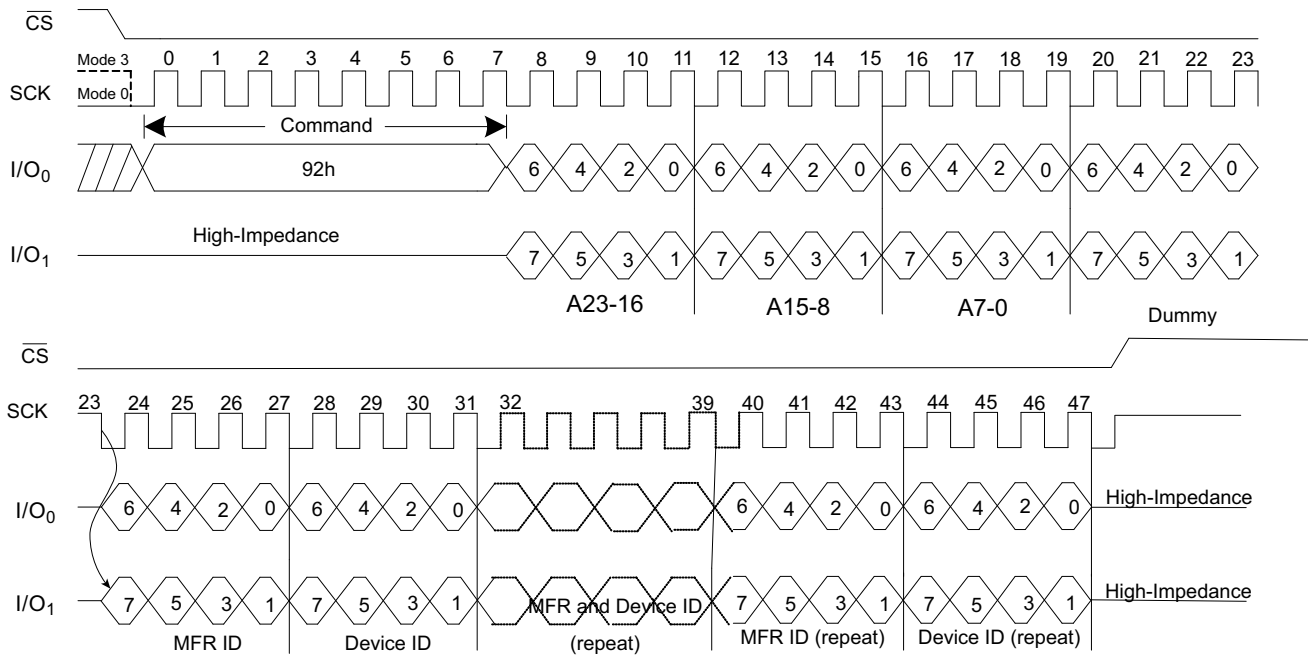

Figure 34. Dual I/O Read Manufacture ID/ Device ID Timing

12.4 Quad I/O Read Manufacturer ID / Device ID (94h)

The Quad I/O Read Manufacturer/Device ID command is an alternative to the Release from Power-Down/Device ID command that provides both the JEDEC assigned Manufacturer ID and the specific Device ID by quad I/O.

The command is initiated by driving the \overline{CS} pin low and shifting the command code 94h, followed by a 24-bit address (A23 - A0) of 000000h and four dummy clocks. If the 24-bit address is initially set to 000001h, the Device ID is read out first.

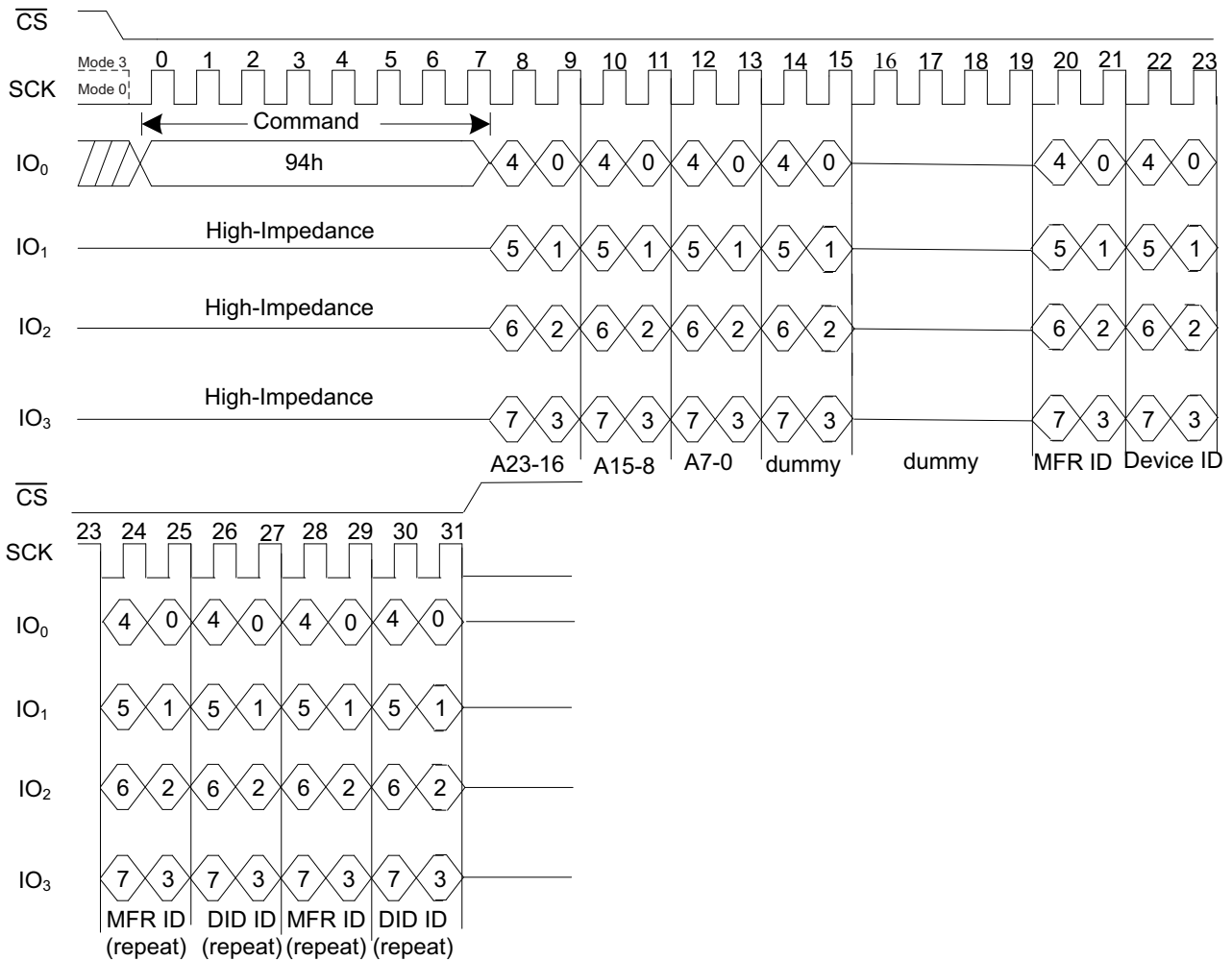

Figure 35. Quad I/O Read Manufacturer ID / Device ID Timing

12.5 Deep Power-Down (B9h)

During normal operation, the device is placed in Standby Mode to consume less power as long as the \overline{CS} pin remains deasserted and no internal operation is in progress. The Deep Power-Down command lets the device be put into an even lower-power consumption state, called the Deep Power-Down mode.

When the device is in the Deep Power-Down mode, all commands, including the Read Status Register command, are ignored, with the exception of the Resume from Deep Power-Down command. Since all commands are ignored, the mode can be used as an extra protection mechanism against program and erase operations.

Entering the Deep Power-Down mode is done by asserting the \overline{CS} pin, clocking in the opcode of B9h, and then deasserting the \overline{CS} pin. Any additional data clocked into the device after the opcode is ignored. When the \overline{CS} pin is deasserted, the device enters the Deep Power-Down mode.

The complete opcode must be clocked in before the \overline{CS} pin is deasserted, and the \overline{CS} pin must be deasserted on an byte boundary (multiples of eight bits); otherwise, the device aborts the operation and returns to the Standby Mode once the \overline{CS} pin is deasserted. Also, the device defaults to the Standby Mode after a power-cycle.

The Deep Power-Down command is ignored if an internally self-timed operation, such as a program or erase cycle, is in progress. The Deep Power-Down command must be reissued after the internally self-timed operation has been completed in order for the device to enter the Deep Power-Down mode.

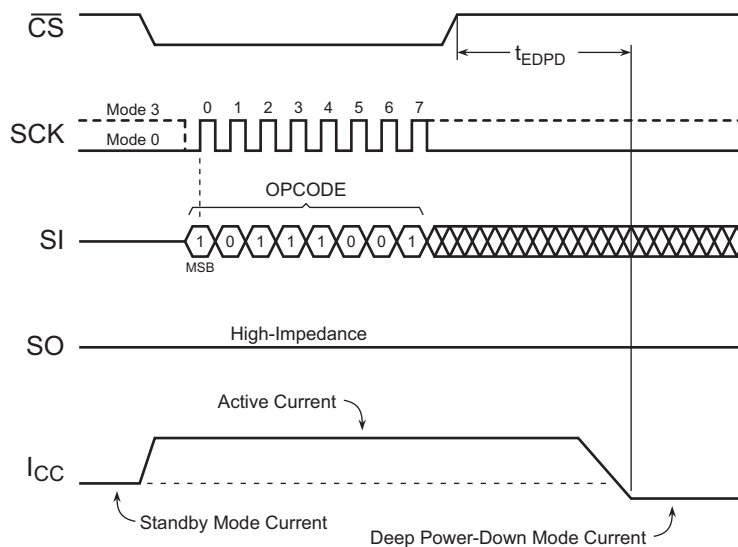

Figure 36. Deep Power-Down

12.6 Resume from Deep Power-Down (ABh)

To exit the Deep Power-Down mode and resume normal device operation, the Resume from Deep Power-Down command must be issued. The Resume from Deep Power-Down command is the only command that the device recognizes while in the Deep Power-Down mode.

To resume from the Deep Power-Down mode, the \overline{CS} pin must be asserted first, and the opcode of ABh must be clocked into the device. Any additional data clocked into the device after the opcode is ignored. When the \overline{CS} pin is deasserted, the device exits the Deep Power-Down mode and returns to the Standby Mode. After the device has returned to the Standby Mode, normal command operations, such as Read Array, can be resumed.

If the complete opcode is not clocked in before the \overline{CS} pin is deasserted, or if the \overline{CS} pin is not deasserted on an byte boundary (multiples of eight bits), the device aborts the operation and returns to the Deep Power-Down mode.

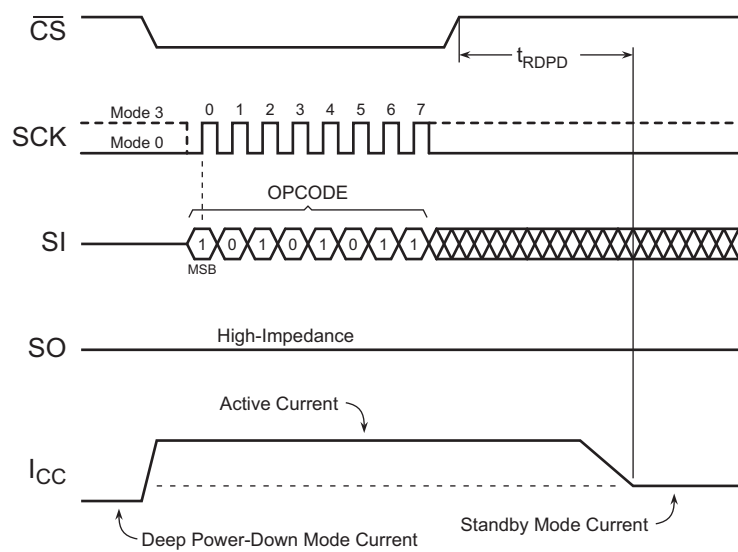

Figure 37. Resume from Deep Power-Down

12.6.1 Resume from Deep Power-Down and Read Device ID (ABh)

The Resume from Deep Power-Down command also can be used to read the Device ID.

When used to release the device from the Power-Down state and obtain the Device ID, the \overline{CS} pin must first be asserted and opcode ABh must be clocked into the device, followed by three dummy bytes. The Device ID bits are then shifted out on the falling edge of SCK, with the MSB first, as shown in Figure 38. This command only outputs a single byte Device ID. The Device ID value for the AT25SF161B is listed in Table 16.

After the last bit (0) of the Device ID has been clocked out, the sequence repeats itself, starting again with bit 7, as long as the \overline{CS} pin remains asserted and the SCK pin is being pulsed. After \overline{CS} is deasserted, it must remain high until new commands can be received.

The same command can be used to read the device ID when not in power-down mode. In that case, \overline{CS} does not have to remain high after it is deasserted.

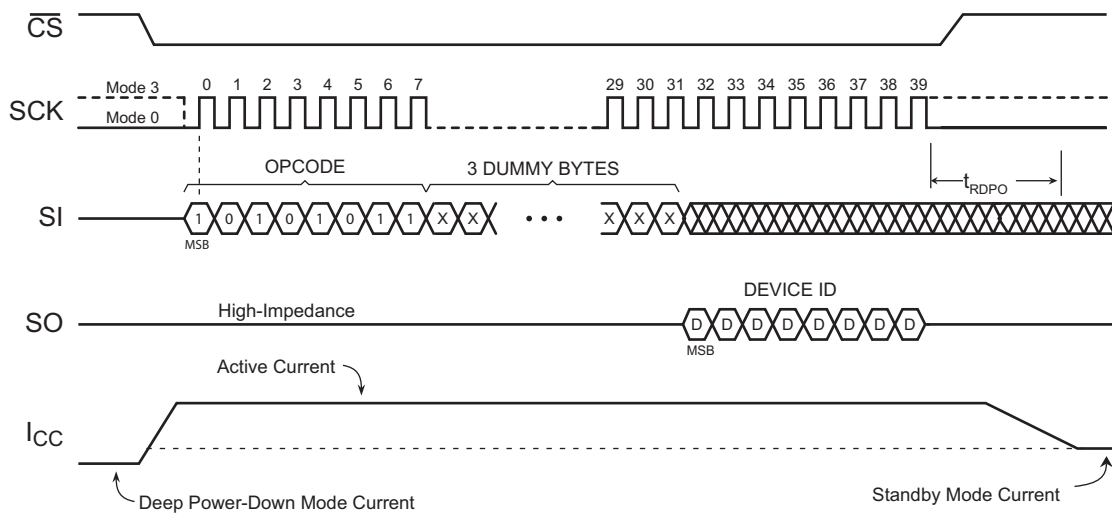

Figure 38. Resume from Deep Power-Down and Read Device ID Timing

12.7 Hold Function

The \overline{HOLD} pin pauses the serial communication with the device without having to stop or reset the clock sequence. The Hold mode, however, does not affect any internally self-timed operations, such as a program or erase cycle. Thus, if an erase cycle is in progress, asserting the \overline{HOLD} pin does not pause the operation, and the erase cycle continues until it is finished.

If the \overline{QE} bit value in the Status Register has been set to logical 1, the \overline{HOLD} pin does not function as a control pin. The \overline{HOLD} pin functions as an output for Quad-Output Read and input/output for Quad-I/O Read.

The Hold mode can only be entered while the \overline{CS} pin is asserted. The Hold mode is activated by asserting the \overline{HOLD} pin during the SCK low pulse. If the \overline{HOLD} pin is asserted during the SCK high pulse, the Hold mode is not started until the beginning of the next SCK low pulse. The device remains in the Hold mode as long as the \overline{HOLD} pin and \overline{CS} pin are asserted.

While in the Hold mode, the SO pin is in a high-impedance state. Also, both the SI pin and the SCK pin are ignored. The \overline{WP} pin, however, can still be asserted or deasserted while in the Hold mode.

To end the Hold mode and resume serial communication, the \overline{HOLD} pin must be deasserted during the SCK low pulse. If the \overline{HOLD} pin is deasserted during the SCK high pulse, the Hold mode does not end until the beginning of the next SCK low pulse.

If the \overline{CS} pin is deasserted while the \overline{HOLD} pin is asserted, any operation that have been started are aborted, and the device resets the WEL bit in the Status Register to the logical 0 state.

13. Electrical Specifications

13.1 Absolute Maximum Ratings

Temperature under Bias	-55 °C to +125 °C
Storage Temperature.	-65 °C to +150 °C
All Input Voltages (including NC Pins) with Respect to Ground.	-0.5 V to +4.0 V
All Output Voltages with Respect to Ground.	-0.6 V to $V_{CC} + 0.5 V$

Notice: Stresses beyond those listed here can cause permanent damage to the device. This is a stress rating only; functional operation of the device at these or any other conditions beyond those indicated in the operational sections of this specification is not implied. Exposure to absolute maximum rating conditions for extended periods can affect device reliability.

13.2 DC and AC Operating Range

Parameter	Condition	Value
Operating Temperature (Case)	Industrial	-40 °C to 85 °C
V_{CC} Power Supply		2.5 V to 3.6 V or 2.5 V to 3.6 V

13.3 DC Characteristics

Symbol	Parameter	Condition	2.5 V to 3.6 V			Units
			Min	Typ ¹	Max	
I_{DPD}	Deep Power-Down Current	$\overline{CS}, \overline{HOLD}, \overline{WP} = V_{IH}$ All inputs at CMOS levels		1.5	10	μA
I_{SB}	Standby Current	$\overline{CS}, \overline{HOLD}, \overline{WP} = V_{IH}$ All inputs at CMOS levels		15	30	μA
I_{CC1}	Active Current, Read (03h, 0Bh) Operation	f = 20 MHz; $I_{OUT} = 0$		4.0	5	mA
		f = 50 MHz; $I_{OUT} = 0$		4.5	6	mA
		f = 85 MHz; $I_{OUT} = 0$		5.5	7	mA
I_{CC2}	Active Current, (3Bh, BBh) Read Operation (Dual)	f = 50 MHz; $I_{OUT} = 0$		5.5	7	mA
		f = 85 MHz and 104 MHz; $I_{OUT} = 0$		7.5	10	mA
I_{CC3}	Active Current, (6Bh, EBh) Read Operation (Quad)	f = 50 MHz; $I_{OUT} = 0$		7	9	mA
		f = 85 MHz and 104 MHz; $I_{OUT} = 0$		10	13	mA
I_{CC4}	Active Current, Program Operation	$\overline{CS} = V_{CC}$			20	mA
I_{CC5}	Active Current, Erase Operation	$\overline{CS} = V_{CC}$			14	mA
I_{LI}	Input Load Current	All inputs at CMOS levels			±2	μA
I_{LO}	Output Leakage Current	All inputs at CMOS levels			±2	μA
V_{IL}	Input Low Voltage		-0.5		$V_{CC} \times 0.2$	V
V_{IH}	Input High Voltage		$V_{CC} \times 0.8$		$V_{CC} + 0.4$	V
V_{OL}	Output Low Voltage	$I_{OL} = 100 \mu A$			0.4	V
V_{OH}	Output High Voltage	$I_{OH} = -100 \mu A$	$V_{CC} - 0.2$			V

1. Measured at 3.0 V @ 25 °C.

13.4 AC Characteristics - Maximum Clock Frequencies

Symbol	Parameter	2.5 V to 3.6 V			Units
		Min	Typ	Max	
f _{CLK}	Maximum Clock Frequency for all opcodes except for 03h, 0Bh, 3Bh, and 6Bh			108	MHz
f _{CLK1}	Maximum Clock Frequency for opcodes 0Bh, 3Bh, and 6Bh			85	MHz
f _{CLK2}	Maximum Clock Frequency for 03h opcode			55	MHz

Symbol	Parameter	2.5 V to 3.6 V			Units
		Min	Typ	Max	
t _{CLKH}	Clock High Time	4			ns
t _{CLKL}	Clock Low Time	4			ns
t _{CLKR}	Clock Rise Time, Peak-to-Peak (Slew Rate) ¹	0.1			V/ns
t _{CLKF}	Clock Fall Time, Peak-to-Peak (Slew Rate) ¹	0.1			V/ns
t _{CSH}	\overline{CS} High Time	20			ns
t _{CSLS}	\overline{CS} Low Setup Time (relative to Clock)	5			ns
t _{CSLH}	\overline{CS} Low Hold Time (relative to Clock)	5			ns
t _{CSHS}	\overline{CS} High Setup Time (relative to Clock)	5			ns
t _{CSHH}	\overline{CS} High Hold Time (relative to Clock)	5			ns
t _{DS}	Data In Setup Time	2			ns
t _{DH}	Data In Hold Time	2			ns
t _{DIS}	Output Disable Time ¹			6	ns
t _V	Output Valid Time			7	ns
t _{OH}	Output Hold Time	0			ns
t _{HLS}	\overline{HOLD} Low Setup Time (relative to Clock)	5			ns
t _{HLH}	\overline{HOLD} Low Hold Time (relative to Clock)	5			ns
t _{HHS}	\overline{HOLD} High Setup Time (relative to Clock)	5			ns
t _{HHH}	\overline{HOLD} High Hold Time (relative to Clock)	5			ns
t _{HLQZ}	\overline{HOLD} Low to Output High-Z ¹			6	ns
t _{HHQZ}	\overline{HOLD} High to Output High-Z ¹			6	ns
t _{RES1}	\overline{CS} High to Standby Mode Without Electronic Signature Read			20	μs
t _{RES2}	\overline{CS} High to Standby Mode With Electronic Signature Read			20	μs
t _{SUS}	\overline{CS} High to Next Command After Suspend			20	μs
t _{WPS}	Write Protect Setup Time ¹	20			ns
t _{WPH}	Write Protect Hold Time ¹	100			ns
t _{EDPD}	\overline{CS} High to Deep Power-Down			20	μs
t _{RDPD}	\overline{CS} High to Standby Mode			20	μs
t _{RDPO}	Resume Deep Power-Down, \overline{CS} High to ID			20	μs

1. Not 100% tested. Value guaranteed by design and characterization.

13.5 Program and Erase Characteristics

Symbol	Parameter	Condition	2.5 V to 3.6 V			
			Min	Typ ¹	Max ²	Units
t _{PP}	Page Program Time (256 Bytes)			0.4	1.8	ms
t _{BP1}	Byte Program Time (First Byte)			30	50	μs
t _{BP2} ⁴	Additional Byte Program Time (After First Byte)			1.5	6.9	μs
t _{BLKE}	Block Erase Time	4 kbyte		50	220	ms
		32 kbyte		120	450	
		64 kbyte		200	700	
t _{CHPE 3}	Chip Erase Time			5.5	11	s
t _{WRSR}	Write Status Register Time			5	30	ms

1. Measured at 3.0 V @ 25 °C.
2. Unless specified otherwise, maximum is worst-case after 100k cycles.
3. Max spec based on limited endurance cycle.
4. The time to program N bytes can be calculated as follows: t_{BP1} + (N - 1) * t_{BP2}.

13.6 Power-Up Conditions

Symbol	Parameter	Min	Max	Units
t _{VSL}	Minimum V _{CC} to Chip Select Low Time	70		μs

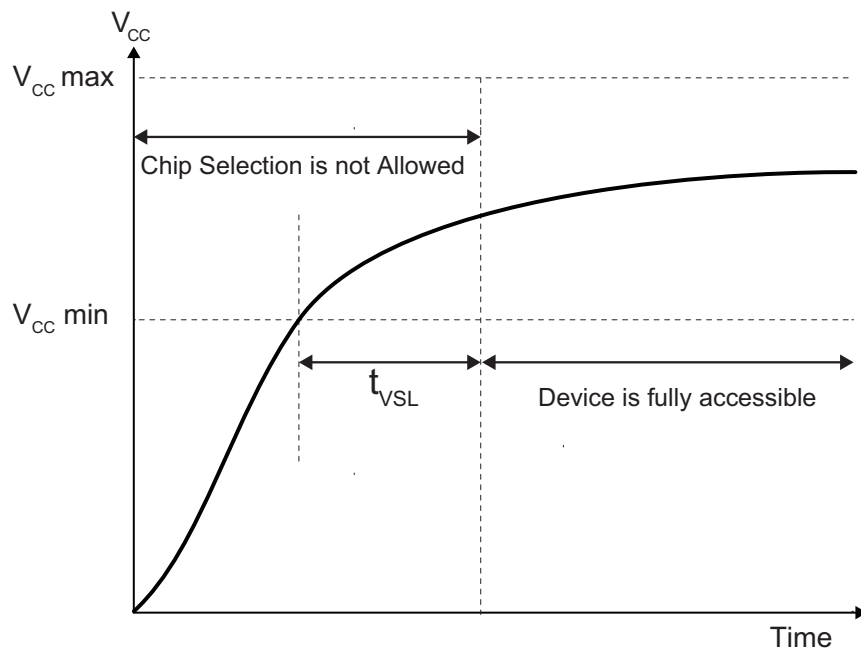
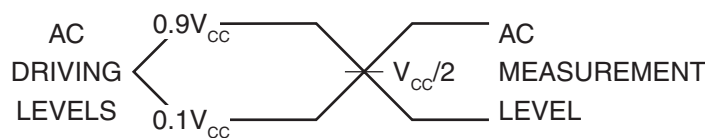
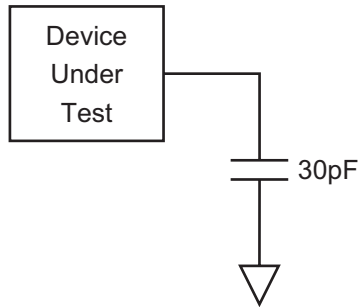

Figure 39. Power-Up Timing and Voltage

13.7 Input Test Waveforms and Measurement Levels



13.8 Output Test Load



14. AC Waveforms

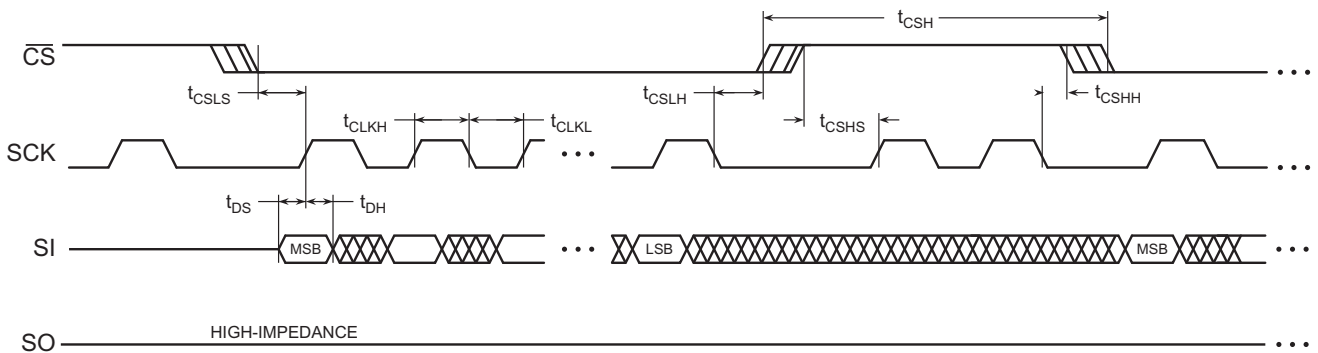

Figure 40. Serial Input Timing

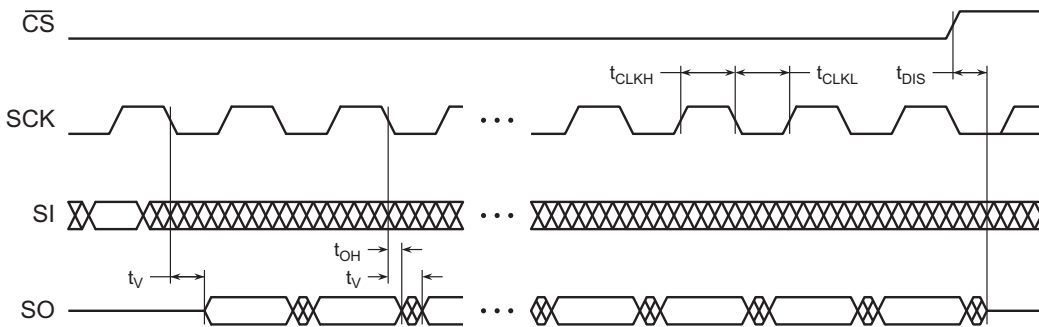

Figure 41. Serial Output Timing

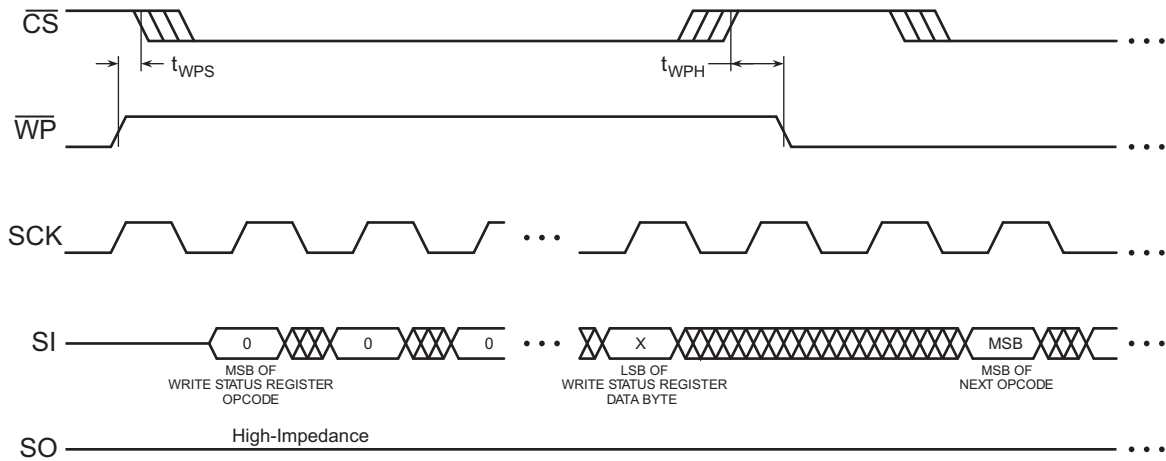

Figure 42. \overline{WP} Timing for Write Status Register Command When BPL = 1

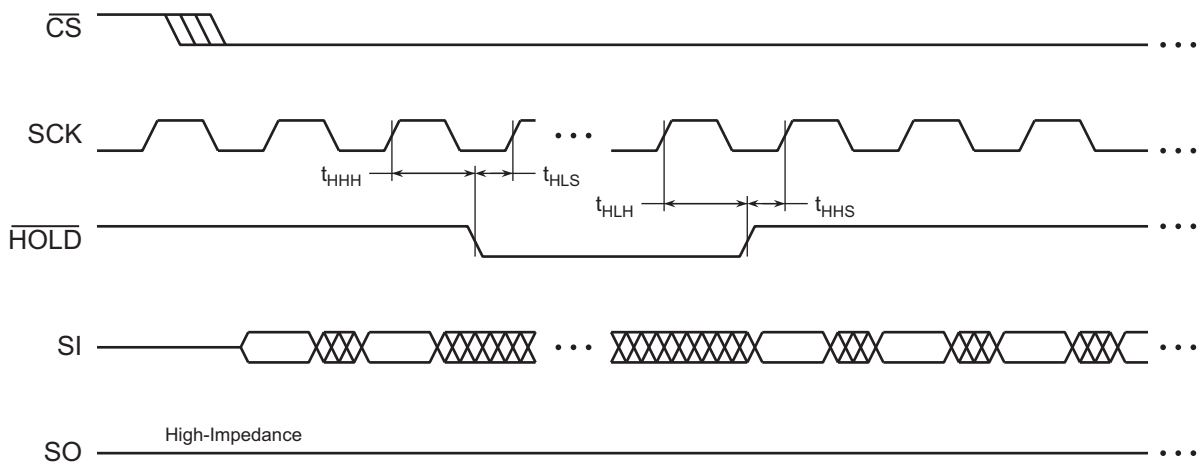

Figure 43. \overline{HOLD} Timing – Serial Input

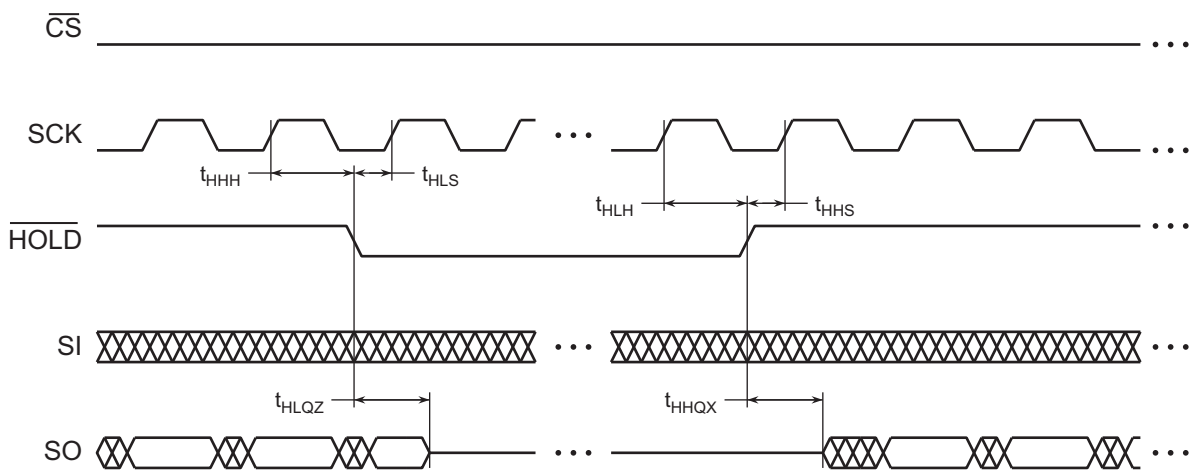
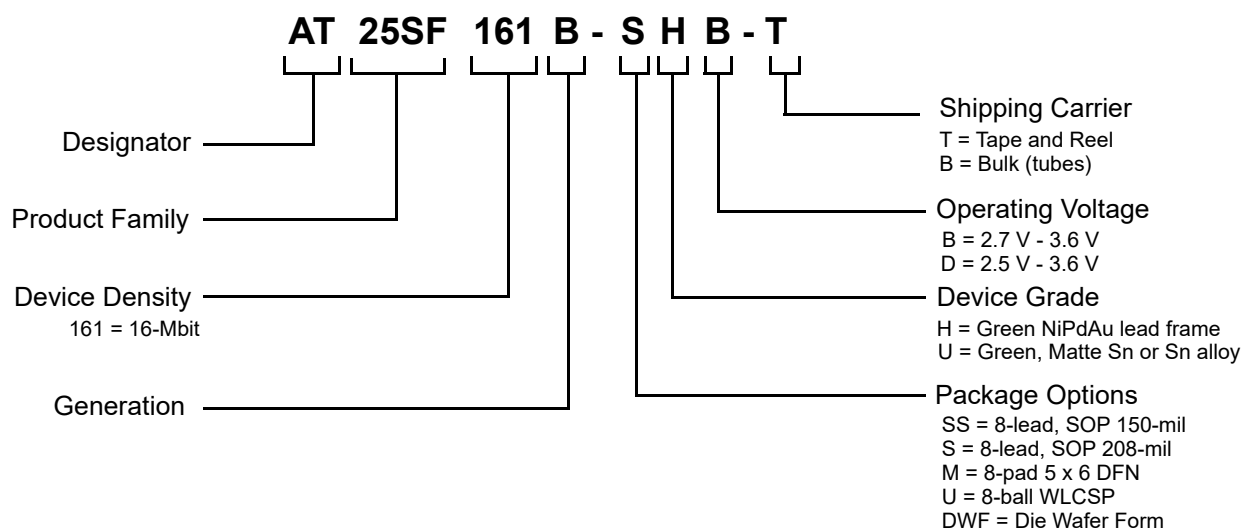

Figure 44. \overline{HOLD} Timing – Serial Output

15. Ordering Information



Ordering Code ¹	Package Description	Operating Voltage	Max. Freq.	Operation Range
AT25SF161B-SSHB-B	8-lead, 150-mil Narrow, Plastic Gull Wing Small Outline Package (JEDEC SOIC)	2.7 V to 3.6 V	108 MHz	-40 °C to +85 °C
AT25SF161B-SSHB-T				
AT25SF161B-SHB-B	8-lead, 208-mil Wide, Plastic Gull Wing Small Outline Package (EIAJ SOIC)			
AT25SF161B-SHB-T				
AT25SF161B-MHB-T	8-pad (5 x 6 x 0.6 mm body), Thermally Enhanced Plastic Dual Flat No-lead (DFN)			
AT25SF161B-UUB-T	8-ball, 3 x 2 x 3 mm Ball Matrix, 0.35 mm Z-Height			
AT25SF161B-DWF ²	Die Wafer Form.			
AT25SF161B-SSHD-B	8-lead, 150-mil Narrow, Plastic Gull Wing Small Outline Package (JEDEC SOIC)	2.5 V to 3.6 V	108 MHz	-40 °C to +85 °C
AT25SF161B-SSHD-T				
AT25SF161B-SHD-B	8-lead, 208-mil Wide, Plastic Gull Wing Small Outline Package (EIAJ SOIC)			
AT25SF161B-SHD-T				
AT25SF161B-MHD-T	8-pad (5 x 6 x 0.6 mm body), Thermally Enhanced Plastic Dual Flat No-lead (DFN)			
AT25SF161B-UUD-T	8-ball, 3 x 2 x 3 mm Ball Matrix, 0.35 mm Z-Height			

1. The shipping carrier option code is not marked on the devices.

2. Contact Renesas Electronics for detailed information.

15.1 8-Pad, 150-mil Narrow JEDEC SOIC

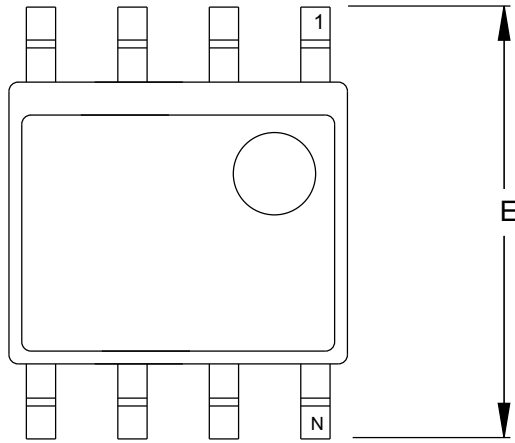

TOP VIEW

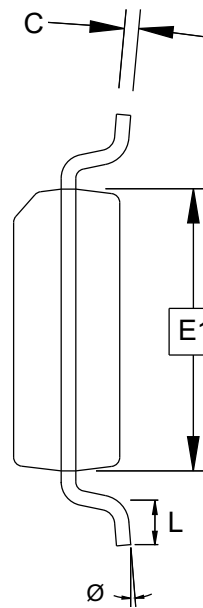

END VIEW

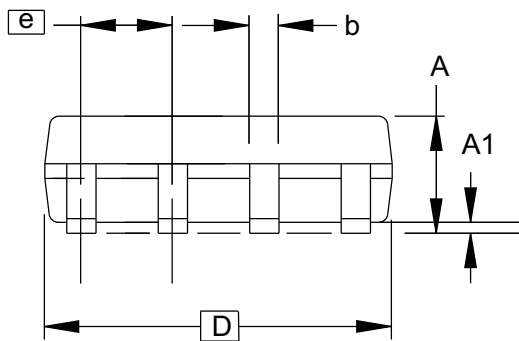

SIDE VIEW

Notes: This drawing is for general information only.
Refer to JEDEC Drawing MS-012, Variation AA
for proper dimensions, tolerances, datums, etc.

COMMON DIMENSIONS
(Unit of Measure = mm)

SYMBOL	MIN	NOM	MAX	NOTE
A	1.35	1.60	1.75	
A1	0.10	0.18	0.25	
b	0.31	0.43	0.51	
C	0.17	0.22	0.25	
D	4.80	4.83	5.05	
E1	3.81	3.90	3.99	
E	5.79	6.00	6.20	
e	1.27 BSC			
L	0.40	0.60	1.27	
Ø	0°	3.75	8°	



15.2 8-Lead, 208-mil Wide EIAJ SOIC

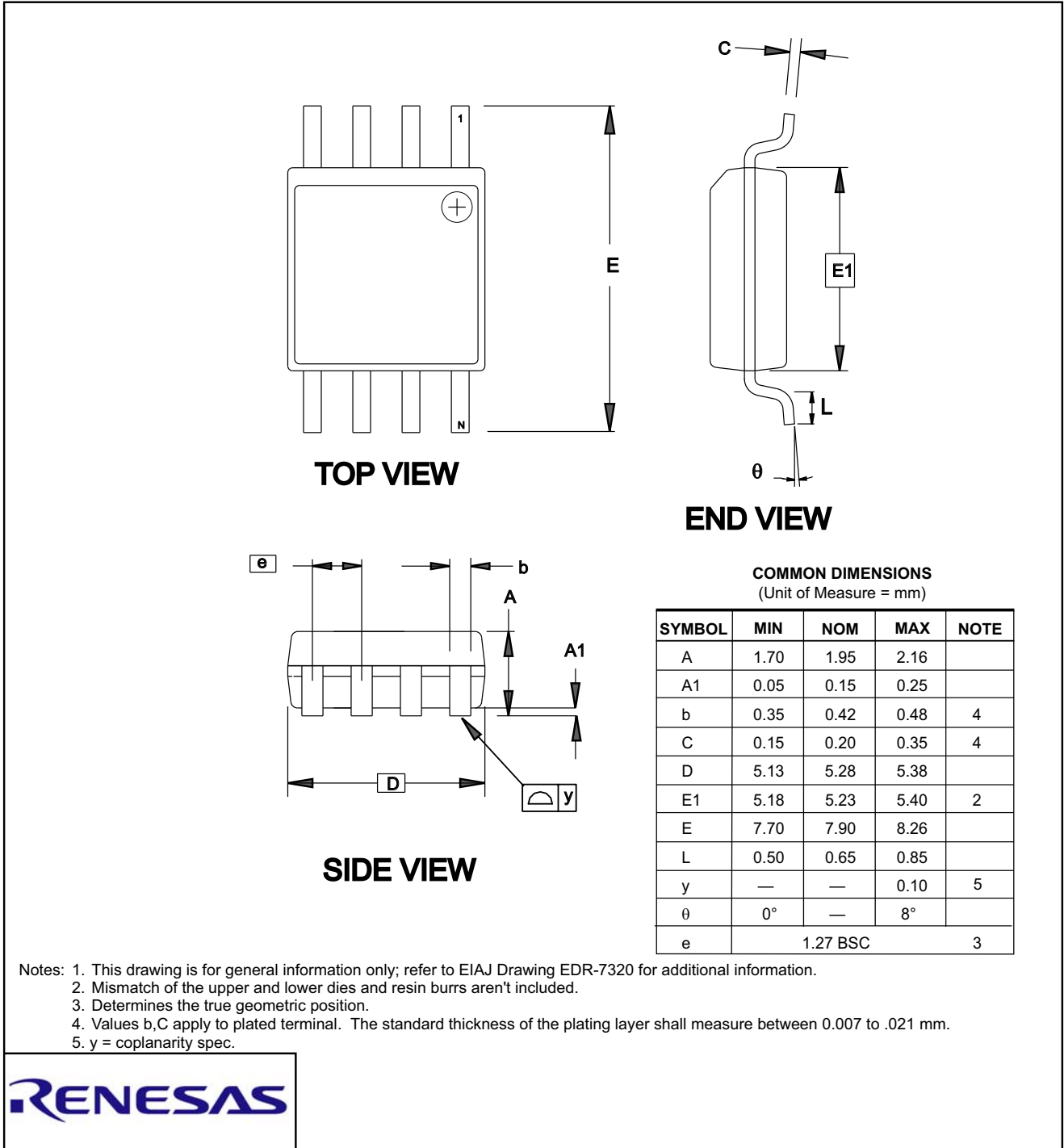

15.3 8-Pad, 5 x 6 x 0.6 DFN

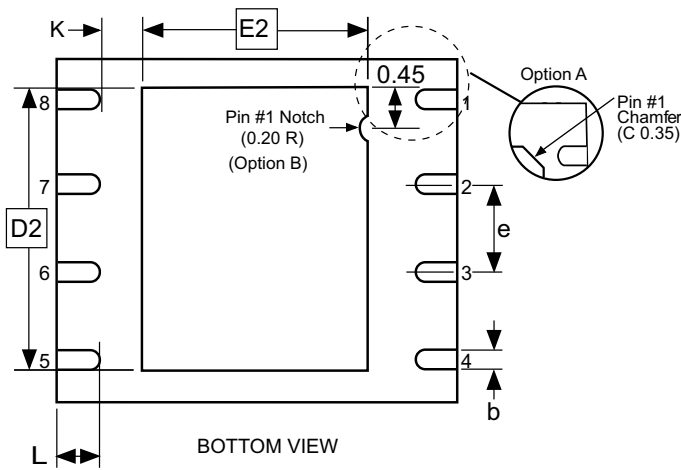
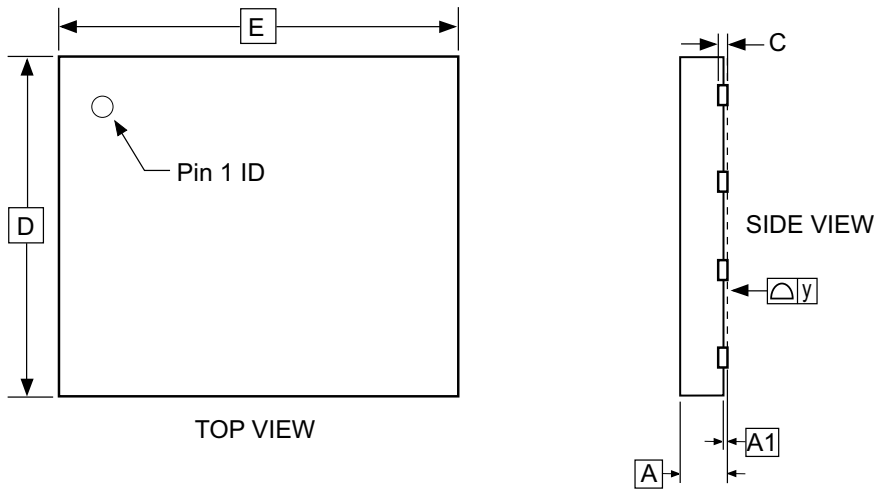

COMMON DIMENSIONS
(Unit of Measure = mm)

SYMBOL	MIN	NOM	MAX	NOTE
A	0.45	0.55	0.60	
A1	0.00	0.02	0.05	
b	0.35	0.40	0.48	
C	0.152 REF			
D	4.90	5.00	5.10	
D2	3.80	4.00	4.20	
E	5.90	6.00	6.10	
E2	3.20	3.40	3.60	
e	1.27			
L	0.50	0.60	0.75	
y	0.00	-	0.08	
K	0.20	-	-	



- Notes: 1. This package conforms to JEDEC reference MO-229, Saw Singulation.
 2. The terminal #1 ID is a laser-marked feature.
 3. The exposed thermal pad is not electrically connected.
 4. It is recommended that the exposed thermal pad be tied to system ground to minimize the possibility of EMI related issues. It is also recommended for mechanical stability.

15.4 8-Ball 3 x 2 x 3 WLCSP

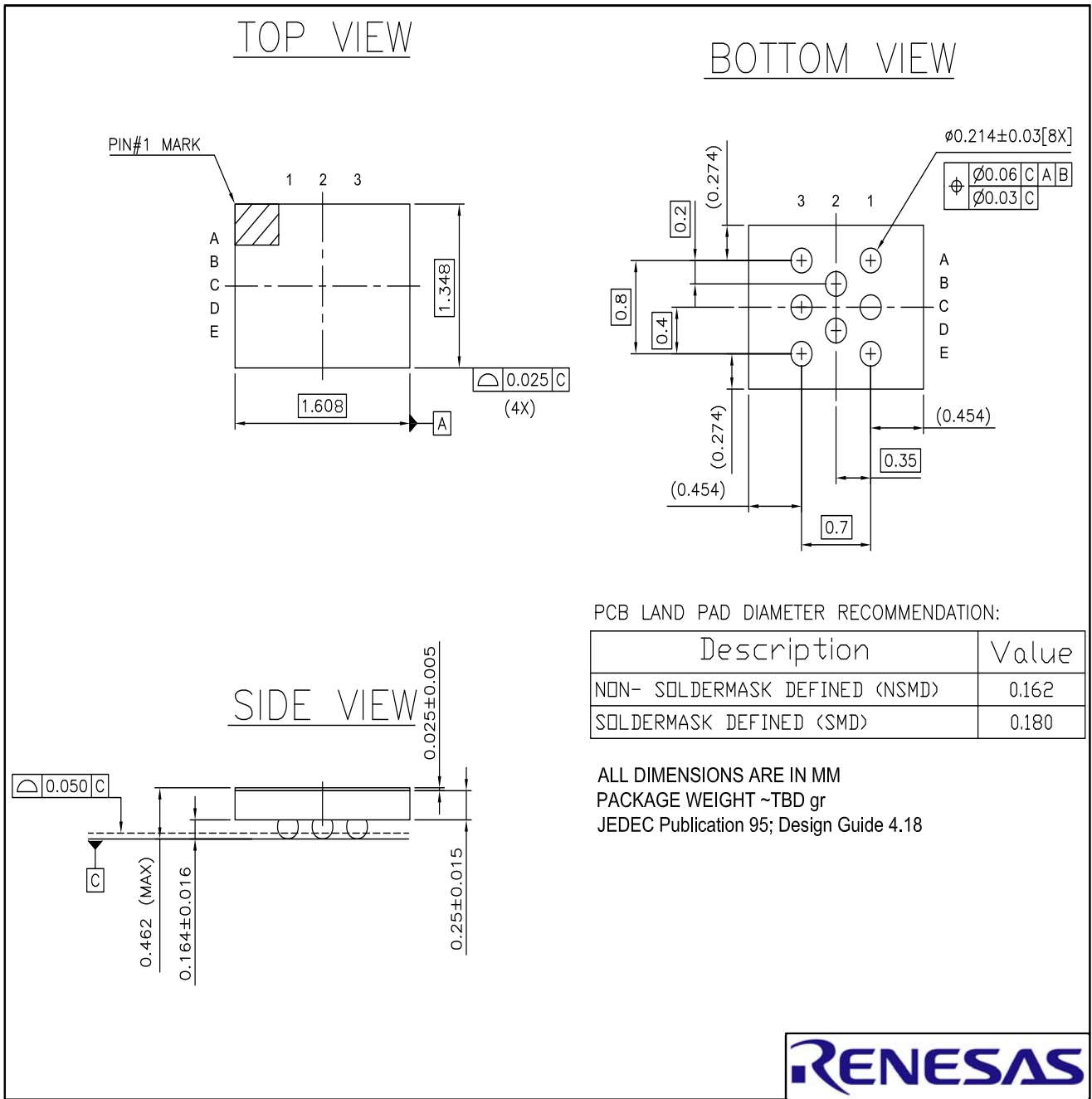

16. Revision History

Revision	Date	Tasks
A	01/2020	Initial release of AT25SF161B data sheet.
B	03/2020	Replaced characterization numbers in tables 13.3 through 13.7. Changed status from Advanced to Preliminary.
C	01/2021	Correction to BP0 value for range 100000h-1FFFFFFh in Table 9-2.
D	03/2021	Transferred to new Dialog Semiconductor format. Added 2.5 V - 3.6 V supply voltage option on Features page, sections 13.2, 13.3, 13.4, 13.5, and 13.6. Added support for 2.5 V - 3.6 V to section 15, including new part numbers.
E	04/2021	Removed "Preliminary" from datasheet designation. Finalized numbers in Tables 13.3 and 13.6.
F	06/2022	Applied new corporate template to document. Added physical block size information in Section 1, Product Overview. Added the following note to the end of the description of opcode 75h: "A read operation from a physical block that includes a suspended area might provide unreliable data. For the definition of the physical block and for the techniques to ensure high data integrity, see application note AN-500." Changed the description of \overline{WP} and \overline{HOLD} in Table 1. Added the following sentence to the \overline{CS} description in Table 1: "To ensure correct power-up sequencing, it is recommended to add a 10k Ohm pull-up resistor from \overline{CS} to V_{CC} . This ensures \overline{CS} ramps together with V_{CC} during power-up."
G	03/2024	Changed text in Feature List and Section 1 to conform to new SF device data sheets. Changed values in WLCSP POD (Section 16.4). Made corrections to Section 15, Ordering Information. Changed text in Feature List to conform to new SF device data sheets. Relocated physical block information to Section 4. Changed all instance of WIP to RDY/BSY. Opcode 75h wording updated. See application note AN-500 for operational guidance. Changed the typ and max values for tBP2 in Section 13.5.
H	09/2024	Changed 'UDFN' to 'DFN.' Changed 'Sector' to 'Block.' Corrected pin symbols in various figures. Removed I/O ₀₋₃ from SPI figures and SI/SO from Dual or Quad operations. Updated '8-Lead, 208-mil Wide EIAJ SOIC' POD. Added notes to '8-Pad, 5 x 6 x 0.6 DFN' POD. Updated Figure 39 Power-up Timing and Voltage. Corrected V_{IL} minimum value in section 13.3 'DC Characteristics.' Updated section 13.5 'Program and Erase Characteristics.' Combined Ordering Information and Packaging Information sections.

IMPORTANT NOTICE AND DISCLAIMER

RENESAS ELECTRONICS CORPORATION AND ITS SUBSIDIARIES (“RENESAS”) PROVIDES TECHNICAL SPECIFICATIONS AND RELIABILITY DATA (INCLUDING DATASHEETS), DESIGN RESOURCES (INCLUDING REFERENCE DESIGNS), APPLICATION OR OTHER DESIGN ADVICE, WEB TOOLS, SAFETY INFORMATION, AND OTHER RESOURCES “AS IS” AND WITH ALL FAULTS, AND DISCLAIMS ALL WARRANTIES, EXPRESS OR IMPLIED, INCLUDING, WITHOUT LIMITATION, ANY IMPLIED WARRANTIES OF MERCHANTABILITY, FITNESS FOR A PARTICULAR PURPOSE, OR NON-INFRINGEMENT OF THIRD-PARTY INTELLECTUAL PROPERTY RIGHTS.

These resources are intended for developers who are designing with Renesas products. You are solely responsible for (1) selecting the appropriate products for your application, (2) designing, validating, and testing your application, and (3) ensuring your application meets applicable standards, and any other safety, security, or other requirements. These resources are subject to change without notice. Renesas grants you permission to use these resources only to develop an application that uses Renesas products. Other reproduction or use of these resources is strictly prohibited. No license is granted to any other Renesas intellectual property or to any third-party intellectual property. Renesas disclaims responsibility for, and you will fully indemnify Renesas and its representatives against, any claims, damages, costs, losses, or liabilities arising from your use of these resources. Renesas' products are provided only subject to Renesas' Terms and Conditions of Sale or other applicable terms agreed to in writing. No use of any Renesas resources expands or otherwise alters any applicable warranties or warranty disclaimers for these products.

(Disclaimer Rev.1.01 Jan 2024)

Corporate Headquarters

TOYOSU FORESIA, 3-2-24 Toyosu,
Koto-ku, Tokyo 135-0061, Japan
www.renesas.com

Trademarks

Renesas and the Renesas logo are trademarks of Renesas Electronics Corporation. All trademarks and registered trademarks are the property of their respective owners.

Contact Information

For further information on a product, technology, the most up-to-date version of a document, or your nearest sales office, please visit www.renesas.com/contact-us/.